

Name: _____ Class: 15S _____ Reg Number: _____

**JC2 Preliminary Examination
Higher 2**

Chemistry**9647/01****Paper 1 Multiple-Choice Questions****23 September 2016****1 hour**

Additional Materials: *Data Booklet*
 OMR Answer Sheet

INSTRUCTIONS TO CANDIDATES

Write your name, class and register number in the spaces provided at the top of this page.

There are **forty** questions in this section. Answer **all** questions. For each question, there are four possible answers labelled **A, B, C** and **D**. Choose the **one** you consider correct and record your choice in soft pencil on the OMR answer sheet.

Read very carefully the instructions on the OMR answer sheet.

You are advised to fill in the OMR Answer Sheet as you go along; no additional time will be given for the transfer of answers once the examination has ended.

Use of OMR Answer Sheet

Ensure you have written your name, class register number and class on the OMR Answer Sheet.

Use a **2B** pencil to shade your answers on the OMR sheet; erase any mistakes cleanly. Multiple shaded answers to a question will not be accepted.

For shading of class register number on the **OMR sheet**, please follow the given examples:

If your register number is **1**, then shade **01** in the index number column.

If your register number is **21**, then shade **21** in the index number column.

This document consists of **23** printed pages

Answer all questions in this section.

For each question there are four possible answers, **A**, **B**, **C**, and **D**. Choose the **one** you consider to be correct.

1 Use of the Data Booklet is relevant to this question.

Sodium percarbonate, $(\text{Na}_2\text{CO}_3)_x \cdot y(\text{H}_2\text{O}_2)$, is an oxidising agent in some home and laundry cleaning products.

20.0 cm³ of 0.0500 mol dm⁻³ sodium percarbonate releases 48.0 cm³ of carbon dioxide at room conditions on acidification.

An identical sample, on titration with 0.0500 mol dm⁻³ K₂Cr₂O₇, requires 20.0 cm³ before the first green colour appears. K₂Cr₂O₇ reacts with H₂O₂ in the mole ratio of 1 : 3.

What is the ratio $\frac{y}{x}$?

- A** $\frac{1}{3}$ **B** $\frac{2}{3}$ **C** $\frac{3}{2}$ **D** $\frac{3}{1}$

2 Magnesium nitrate(V), Mg(NO₃)₂ decomposes on heating to form magnesium oxide, nitrogen dioxide and oxygen, while sodium nitrate(V), NaNO₃ decomposes to form NaNO₂ and oxygen only.



A mixture of magnesium nitrate(V) and sodium nitrate(V) was heated until no more gases were evolved. The water soluble part of the residue was used to prepare 1.00 dm³ of solution. 10.00 cm³ of this solution was reacted with 30.00 cm³ of 0.0200 mol dm⁻³ of acidified potassium manganate(VII) solution.

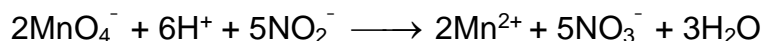

The excess potassium manganate(VII) solution required 10.00 cm³ of 0.0500 mol dm⁻³ ethanedioic acid solution for complete reaction

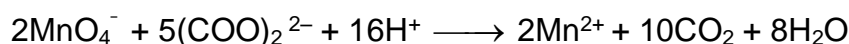

What is the mass of sodium nitrate(V) in the mixture?

Given M_r of NaNO₃ = 85.0

- A** 0.85 g **B** 1.36 g **C** 4.25 g **D** 8.50 g

- 3** *Use of the Data Booklet is relevant to this question.*

Dinitrogen tetroxide, N_2O_4 , has a melting point of $-11\text{ }^\circ\text{C}$ and a boiling point of $21\text{ }^\circ\text{C}$.

A sample of 18.4 g of N_2O_4 (s) is placed in a 24 dm^3 vessel under an atmosphere of helium gas chilled to $-20\text{ }^\circ\text{C}$ at a pressure of 1.0 atm . When the vessel is warmed to $25\text{ }^\circ\text{C}$ and the contents are allowed to reach equilibrium, 40% of the N_2O_4 (g) has dissociated into NO_2 (g).

What is the total pressure of the gases in the vessel at $25\text{ }^\circ\text{C}$?

- A** 0.28 atm **B** 1.28 atm **C** 1.38 atm **D** 1.46 atm

- 4** *Use of the Data Booklet is relevant to this question.*

The ion X^{4+} contains 46 electrons and 69 neutrons.

Which of the following statements about X^{4+} or X^{2+} is correct?

- A** X^{4+} is deflected to approximately twice the extent as Rb^+ when subjected to an electric field.
B X^{4+} has the same electronic configuration as Sr^{2+} .
C X^{2+} undergoes hydration in water to a greater extent than X^{4+} .
D X^{2+} can be oxidised by Fe^{3+} .

- 5** *Use of the Data Booklet is relevant to this question.*

Which particle contains a single unpaired electron?

- A** a molecule of N_2O
B one of the particles formed after the heterolytic fission of a H-Br molecule
C the vanadium ion in VO_2
D the chromium ion in Cr_2O_3

6 Use of the Data Booklet is relevant to this question.

In which of the following pairs of compounds would the first compound have a lower melting point than the second compound?

- A $\text{CH}_3\text{CH}(\text{NH}_2)\text{COOH}$ and $\text{CH}_3\text{CH}(\text{OH})\text{COOH}$
- B $\text{CH}_3\text{CH}_2\text{CH}_2\text{CH}_3$ and $\text{CH}_3\text{CH}(\text{CH}_3)\text{CH}_3$
- C GaF_3 , GaCl_3
- D Na_2S , MgF_2

7 Compound X has the following properties.

- It is very hard.
- It is a lubricant.
- It can conduct electricity in the solid state.

What is the most likely structure of compound X?

- A simple molecular
- B giant molecular
- C giant metallic
- D giant ionic

8 The *Maxwell-Boltzmann* distribution curve shown below is for a chemical reaction in living systems.

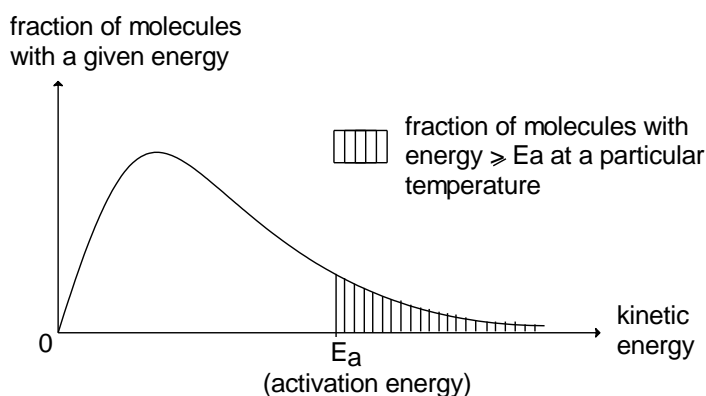

Which statement is **not** true?

- A The total area under the curve is 1.
- B The activation energy will decrease with a decrease in temperature.
- C When temperature is increased, the peak of the curve becomes lower.
- D The shaded area of the curve will decrease when enzymes are denatured.

- 9 Propanone reacts with iodine in the presence of an acid:

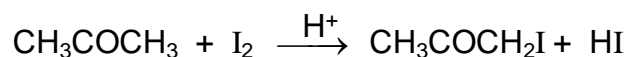

The mechanism involves the following steps.

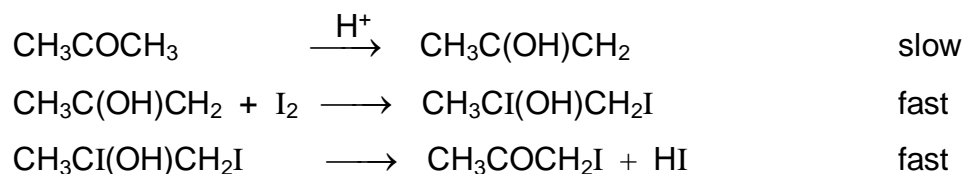

Which graph would be obtained?

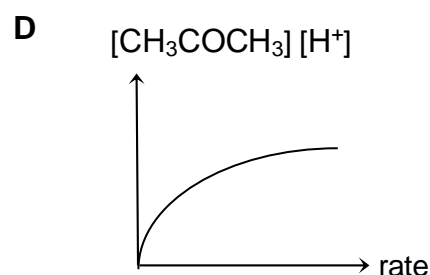
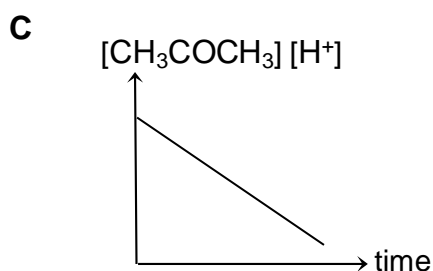
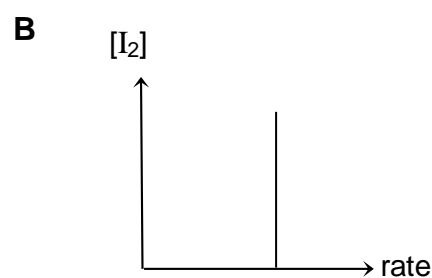
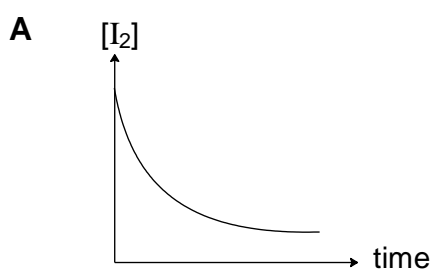

- 10 The following data was obtained from the studies of the reaction between O_2 and NO in a vessel at constant temperature.

Experiment	1	2	3
Initial total pressure of O_2 and NO / atm	1.00	1.30	1.80
Initial partial pressure of O_2 / atm	0.60	0.90	1.20
Initial rate of reaction/ atm s^{-1}	1.08	1.62	4.86

Which of the following statements is correct regarding the above system?

- A** The order of reaction with respect to O_2 is zero.
B The rate constant k has units of $\text{atm}^{-1} \text{s}^{-1}$.
C The rate equation is $\text{rate} = k [\text{NO}][\text{O}_2]^2$.
D The overall order of the reaction is three.

- 11 Aluminium chloride exists in two different forms in the vapour state. When some Al_2Cl_6 was added into a reaction vessel, the following equilibrium is slowly set up.

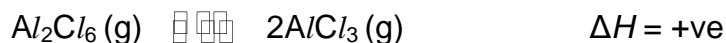

At different times during the experiment, changes were made to the conditions in the reaction vessel. At each time, there was only one change made to the conditions in the reaction vessel.

The change in the concentrations in the mixture with time is shown in the graph below.

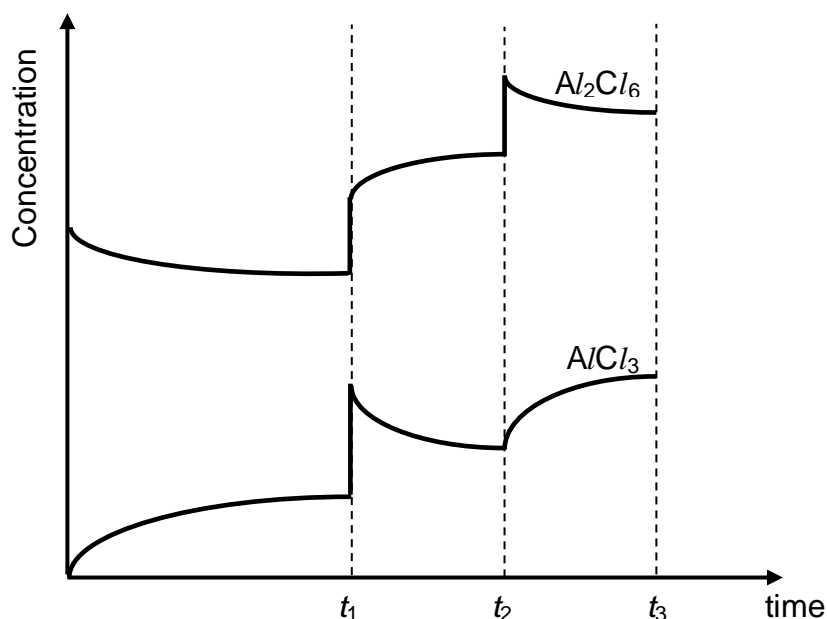

Which conclusion can be drawn from the graph?

- A At t_1 , the pressure of the system was increased by increasing the volume.
- B At t_2 , a catalyst was added to the system.
- C The temperature of the mixture at t_2 was higher than that at t_1 min.
- D The equilibrium constant, K_p , remains the same at t_1 and t_3 .

- 12 Citrate buffers are commonly used to control pH in household cleaners and pharmaceuticals.

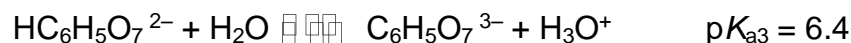
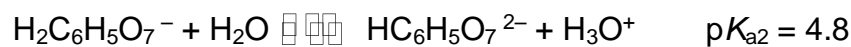
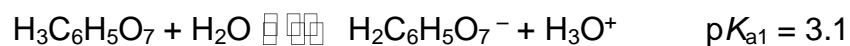

A citrate buffer with pH 5.1 was prepared by dissolving solid $\text{NaH}_2\text{C}_6\text{H}_5\text{O}_7$ and $\text{Na}_2\text{HC}_6\text{H}_5\text{O}_7$. The total sodium concentration of the prepared buffer was 1.0 mol dm^{-3} .

What are the concentrations of $\text{NaH}_2\text{C}_6\text{H}_5\text{O}_7$ and $\text{Na}_2\text{HC}_6\text{H}_5\text{O}_7$ in this buffer?

	$[\text{NaH}_2\text{C}_6\text{H}_5\text{O}_7] / \text{mol dm}^{-3}$	$[\text{Na}_2\text{HC}_6\text{H}_5\text{O}_7] / \text{mol dm}^{-3}$
A	0.10	0.20
B	0.20	0.40
C	0.20	0.10
D	0.40	0.30

- 13 *Use of the Data Booklet is relevant to this question.*

Excess aqueous $(\text{COOH})_2$ was added to an acidified solution of potassium dichromate(VI) in a conical flask. Effervescence was observed until all $(\text{COOH})_2$ had completely reacted. The resulting solution was then left to stand in air for a long time.



What is the colour of the final solution?

- | | | | |
|---|--------|---|--------|
| A | Blue | B | Green |
| C | Yellow | D | Orange |

- 14 When heated, magnesium carbonate decomposes to form carbon dioxide and magnesium oxide.

A graphical plot of ΔG versus T , describing the change of the Gibbs free energy of the decomposition of magnesium carbonate with respect to temperature, is shown below.

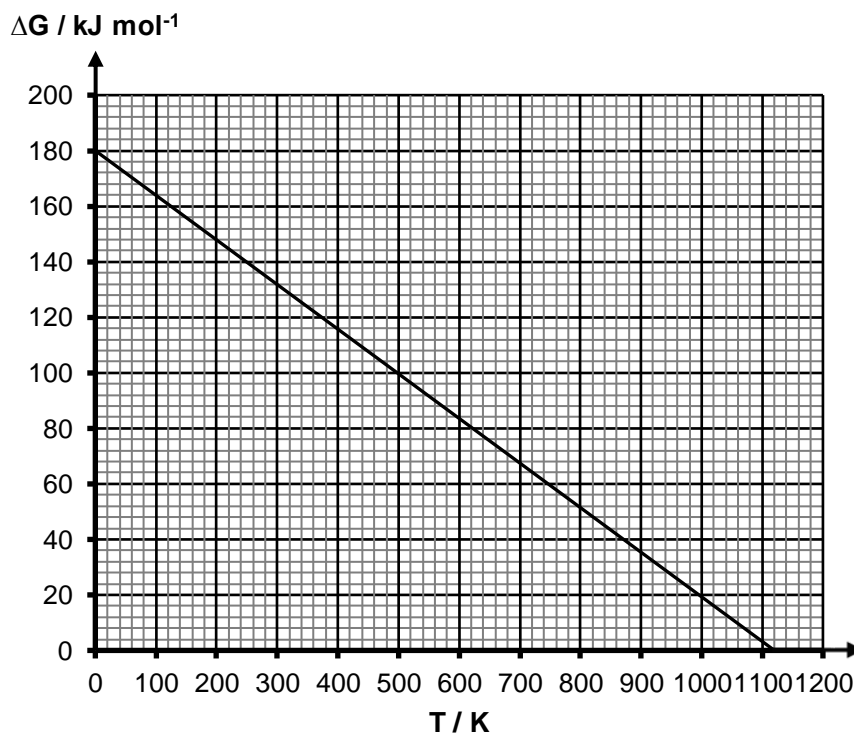

Using the information from the graph, what is the value of ΔS^\ominus for the decomposition reaction?

- A** $+ 6.22 \times 10^3 \text{ J mol}^{-1} \text{ K}^{-1}$ **B** $+ 6.04 \times 10^2 \text{ J mol}^{-1} \text{ K}^{-1}$
C $+ 1.61 \times 10^2 \text{ J mol}^{-1} \text{ K}^{-1}$ **D** $+ 1.80 \times 10^6 \text{ J mol}^{-1} \text{ K}^{-1}$

15 Use of the Data Booklet is relevant to this question.

An electrochemical cell is set up as shown:

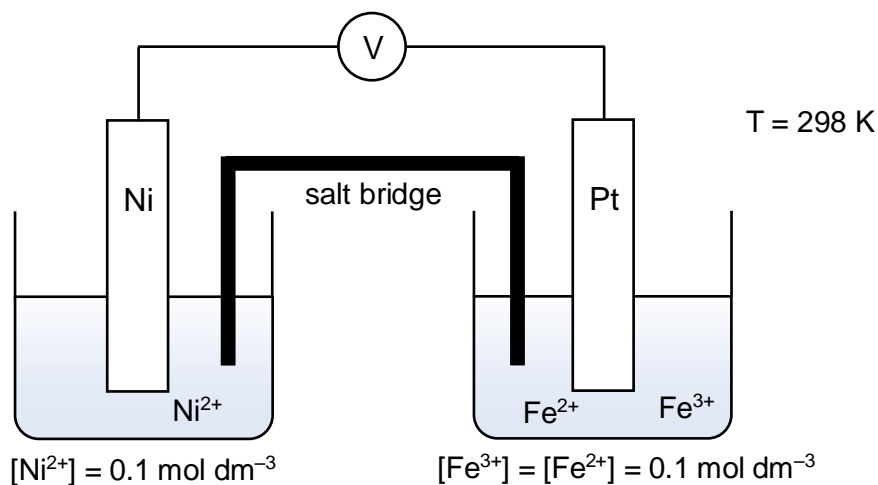

Which statement about the e.m.f. of the above cell is correct?

- A The e.m.f of the cell is +1.02 V.
- B Addition of water to the $\text{Fe}^{3+} / \text{Fe}^{2+}$ half-cell increases the e.m.f of the cell.
- C Increasing the mass of the nickel electrode decreases the e.m.f of the cell.
- D Addition of excess aqueous ammonia to the $\text{Ni}^{2+} / \text{Ni}$ half-cell increases the e.m.f of the cell.

16 In which row of the table are all statements comparing calcium and barium as well as their hydroxides correct?

	Melting point		Flame Test		Solubility of hydroxide	
	Calcium	Barium	Calcium	Barium	$\text{Ca}(\text{OH})_2$	$\text{Ba}(\text{OH})_2$
A	higher	lower	green	red	lower	higher
B	higher	lower	red	green	lower	higher
C	higher	lower	white	green	higher	lower
D	lower	higher	red	green	higher	lower

- 17 Element **Z** is in Period 3 of the Periodic Table. The following four statements were made about the properties of element **Z** or its compounds.

Three statements are correct descriptions and one is false.

Which statement does **not** fit with the other three?

- A Element **Z** burns in oxygen with a bright white flame.
 - B Element **Z** is a solid at room temperature which does not conduct electricity.
 - C The oxide of element **Z** reacts with water to form a solution that turns red on addition of Universal Indicator.
 - D Adding NaOH (aq) to the solution resulting from the reaction of the chloride of **Z** with water produces a white precipitate which is soluble in an excess of NaOH (aq).
- 18 *Use of the Data Booklet is relevant to this question.*

Paramagnetism is the property of being attracted to a magnetic field. Many transition compounds that contain unpaired electrons tend to be paramagnetic while those that do not contain unpaired electrons tend to be diamagnetic. Some compounds are more paramagnetic than others as they contain more unpaired electrons.

A blue solution of VO^{2+} undergoes the following reactions.

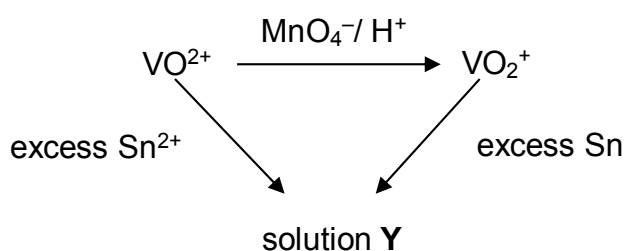

Which of the following statements is **incorrect**?

- A Solution **Y** contains $[\text{V}(\text{H}_2\text{O})_6]^{3+}$.
- B Both Sn^{2+} and Sn act as reducing agents.
- C The reacting ratio of VO^{2+} and MnO_4^- is 5 : 1.
- D VO^{2+} is diamagnetic while VO_2^+ is paramagnetic.

- 19 Three students, **W**, **Y** and **Z**, were asked to draw bar charts to represent how some properties of the halogens and their compounds differ in magnitude.

Their diagrams are shown.

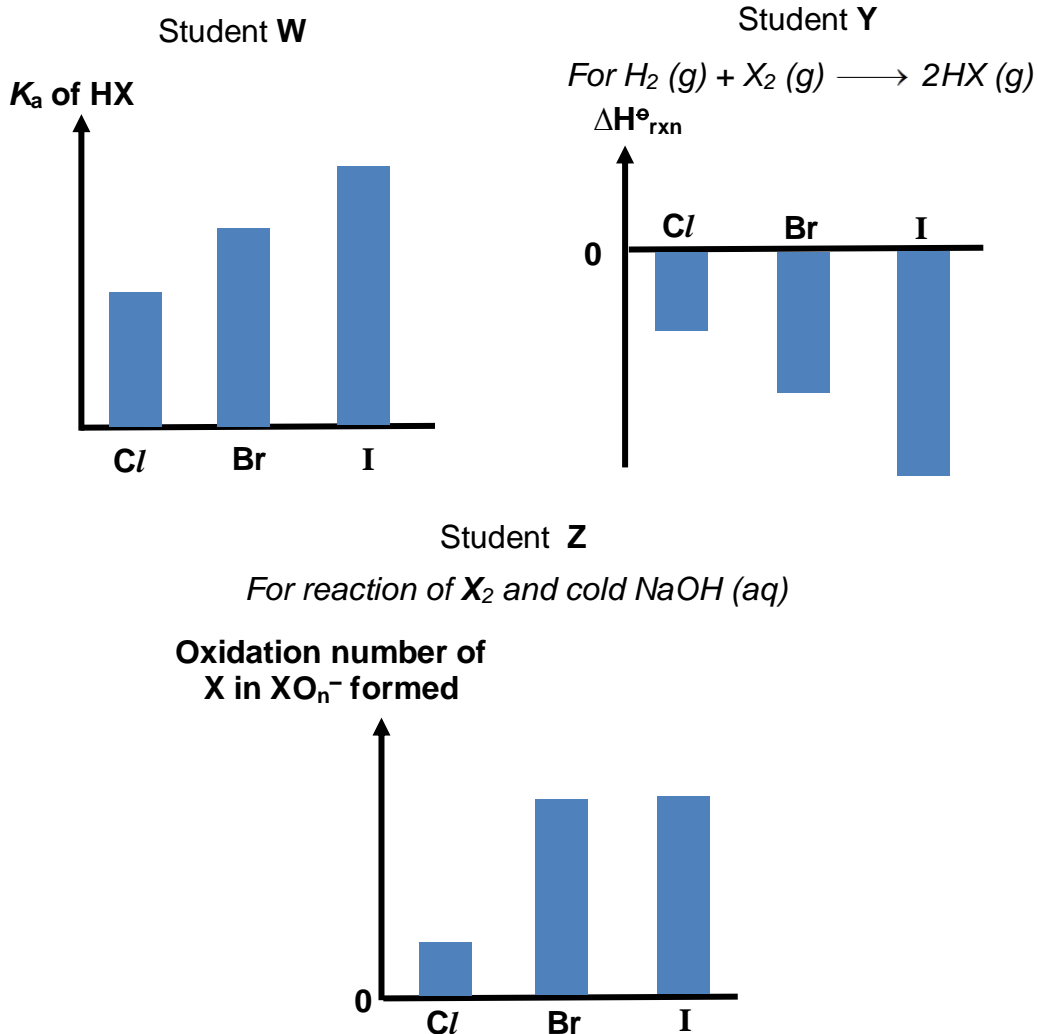

Which of the students' diagrams are correct?

- | | |
|---|---|
| <p>A both W and Z</p> <p>C both Y and Z</p> | <p>B both W and Y</p> <p>D none of the diagrams</p> |
|---|---|
- 20 How many isomers (both structural and stereoisomers) are there for a compound with the formula $C_4H_{10}O$ that can react with $Na(s)$?

- A** 3 **B** 4 **C** 5 **D** 6

- 21 Isopropylcyclohexane reacts with bromine gas to form different mono-substituted products. Three of the products are shown below.

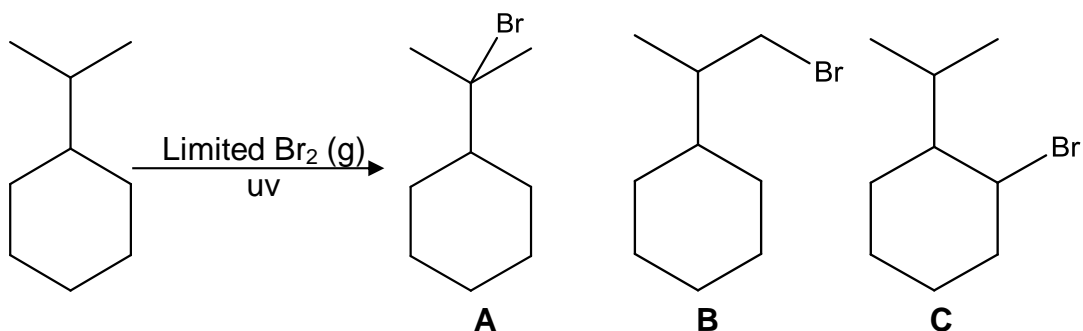

Given that the rate of abstraction of primary, secondary and tertiary hydrogen is 2 : 3 : 6 respectively, what is the expected ratio of the mono-substituted products **A** : **B** : **C** formed?

- A** 6 : 2 : 3 **B** 1 : 1 : 1
C 1 : 2 : 2 **D** 1 : 6 : 4
- 22 Which of the following reactions will **not** incorporate deuterium (D) into any of the organic products formed? (D = ${}^2_1\text{H}$, an isotope of hydrogen)

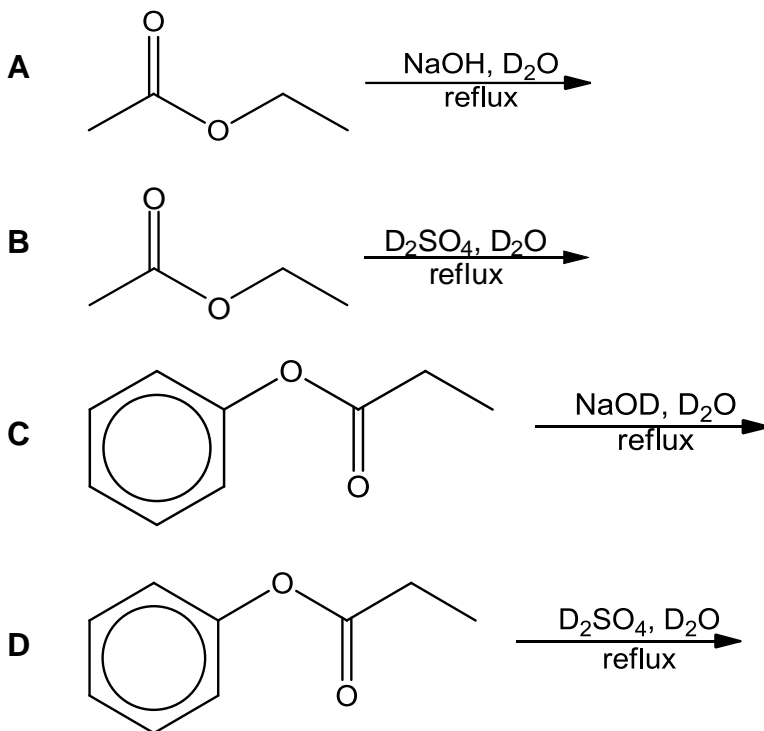

- 23 Phenyl acetate is commonly used in the laboratory as a precursor for organic synthesis.

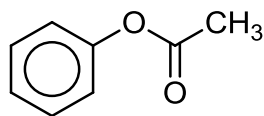

phenyl acetate

Which pair of compounds would produce phenyl acetate in high yield when reacted together?

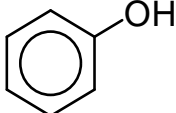
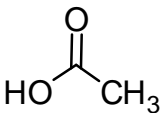
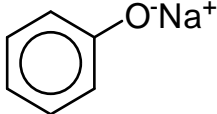
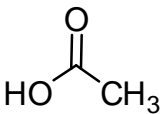
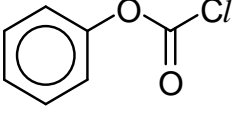
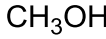
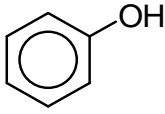
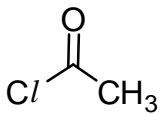
- A  
- B  
- C  
- D  

Use of the following reaction scheme is relevant for Q24 and Q25.

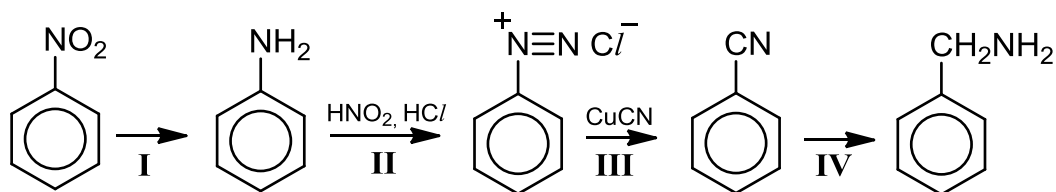

- 24 Which of the following statements is correct about the reaction scheme?
- A The reagent for stage I is LiAlH_4 .
- B Stage II is neutralisation reaction.
- C Stage III is nucleophilic substitution reaction.
- D The reagent for stage IV is hot aqueous NaOH .

- 25 Stage II is the formation of the diazonium salt, which can undergo coupling reactions with other organic compounds, such as phenol, to form azo compounds which are useful dyes.

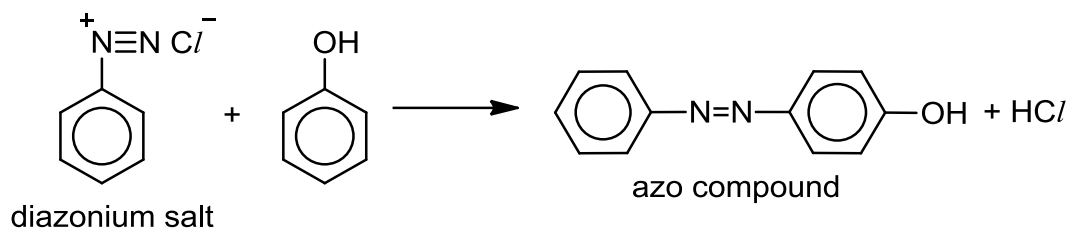

What is the structure of the azo compound formed when **P** and **Q** react together in the presence of HNO_2 and HCl ?

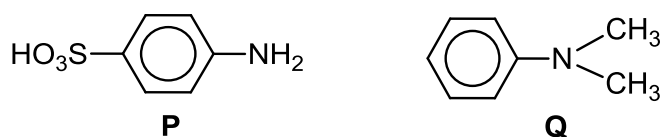

- A**
- B**
- C**
- D**

- 26 Williamson ether synthesis is a very useful reaction in the formation of ethers via the S_N2 mechanism shown below.

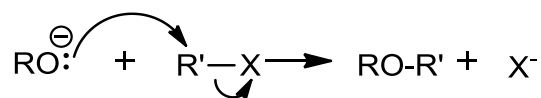

Which of the following compounds will be formed as a **major** product when compound **Y** undergoes Williamson ether synthesis followed by acidification?

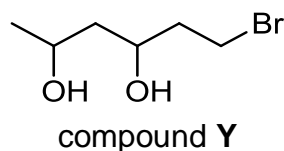

- A**
- B**
- C**
- D**

- 27 When a conjugated diene undergoes electrophilic addition with Br_2 , it forms two products through the 1,2-addition and the 1,4-addition, which is shown in the mechanism below.

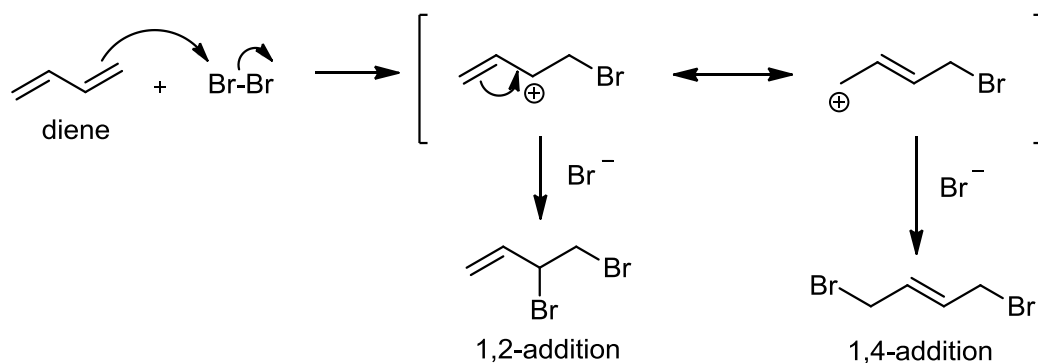

Which of the following statements is **not** correct?

- A** The overall rate law is second order.
- B** The carbocation intermediates are resonance stabilised.
- C** The 1,2-addition product formed when HCl is used is
- D** The 1,4-addition product formed when ICl is used is

- 28 Which of the following shows the given species arranged in order of decreasing K_b values?

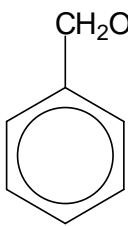
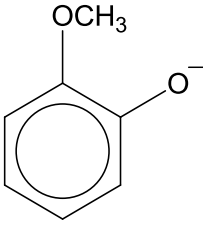
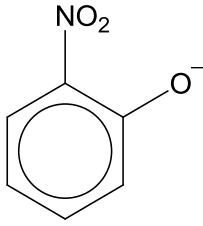
$\text{CH}_3\text{CH}(\text{I})\text{COO}^-$			
I	II	III	IV

- A I, III, IV, II B I, IV, III, II
 C II, III, IV, I D II, IV, III, I
- 29 The rod cells at the back of the eye contain a primary alcohol called *retinol* which is responsible for their sensitivity to light. *Retinol* is oxidised by an enzyme-catalysed reaction that keeps the double bonds intact, to *retinal*, an aldehyde.

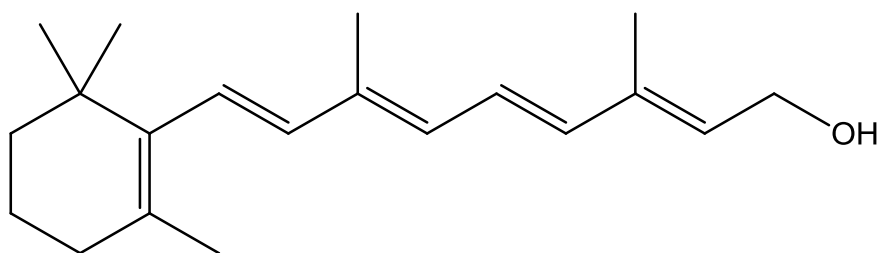

retinol

Which of the following is correct?

- A The number of stereoisomers in *retinol* is 32.
 B There are six σ bonds formed by $2sp^2-2sp^3$ overlap in a molecule of *retinol*.
 C In laboratory preparations, *retinal* can be formed from heating *retinol* under reflux with hot potassium dichromate(VI).
 D One mole of *retinol* reacts with 4 moles of hydrogen gas in the presence of palladium catalyst.

30 The table below gives some information pertaining to three amino acids.

amino acid	structure	isoelectric point
lysine (lys)	$\begin{array}{c} \text{O} \\ \parallel \\ \text{H}_2\text{N}-\text{CH}-\text{C}-\text{OH} \\ \\ (\text{CH}_2)_4\text{NH}_2 \end{array}$	9.6
serine (ser)	$\begin{array}{c} \text{O} \\ \parallel \\ \text{H}_2\text{N}-\text{CH}-\text{C}-\text{OH} \\ \\ \text{CH}_2\text{OH} \end{array}$	5.7
aspartic acid (asp)	$\begin{array}{c} \text{O} \\ \parallel \\ \text{H}_2\text{N}-\text{CH}-\text{C}-\text{OH} \\ \\ \text{CH}_2\text{COOH} \end{array}$	2.9

A mixture of these three amino acids can be separated by electrophoresis.

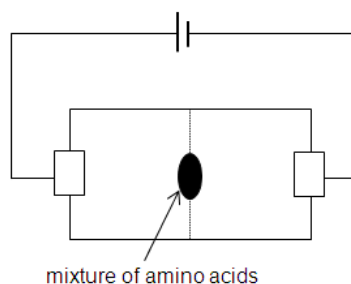

Which of the following diagrams shows the result of the separation of the amino acids mixture at pH 7.0?

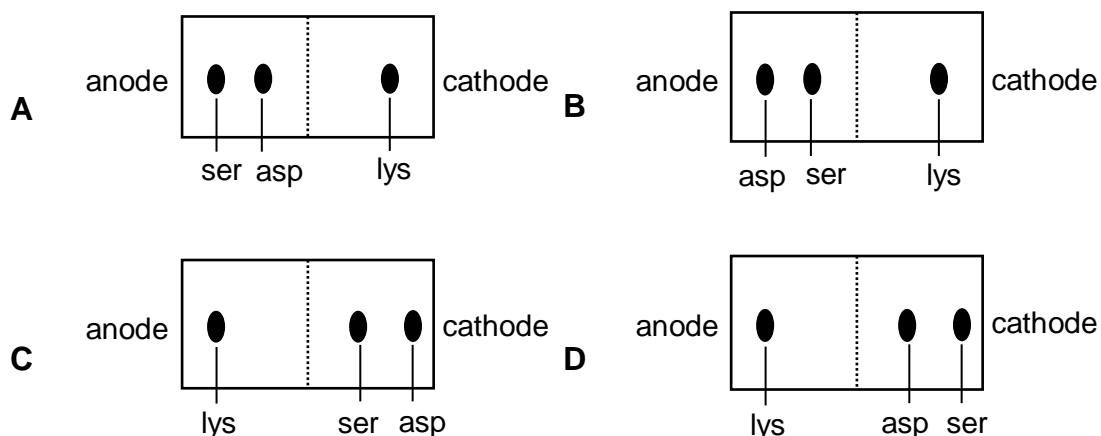

For questions 31 to 40, one or more of the three numbered statements 1 to 3 may be correct. Decide whether each of the statements is or is not correct (you may find it helpful to put a tick against the statements which you consider to be correct.)

The responses **A** to **D** should be selected on the basis of

A	B	C	D
1, 2 and 3 are correct	1 and 2 only are correct	2 and 3 only are correct	1 only is correct

No other combination of statements is used as a correct response.

- 31** In a closed reaction vessel of 10 dm³ maintained at a temperature of 150 °C, gaseous hydrazine decomposes into nitrogen and hydrogen. The system reaches equilibrium with a total pressure of 1 atm.

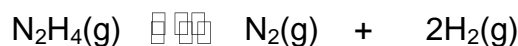

The average M_r of the equilibrium gas mixture in the 10 dm³ vessel is found to be 20.

Which of the following statements are correct?

- In liquid form, both reactants and products flowing from a burette remain undeflected when subjected to close vicinity to a charged rod.
- The mass of the gaseous mixture inside the reaction vessel is 5.75 g.
- The following graphs depicts the correct behaviour of the three gases under standard conditions.

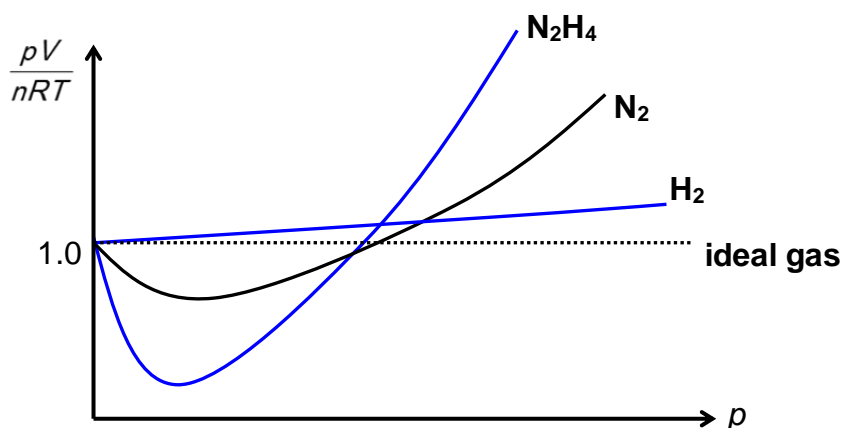

The responses **A** to **D** should be selected on the basis of

A	B	C	D
1, 2 and 3 are correct	1 and 2 only are correct	2 and 3 only are correct	1 only is correct

No other combination of statements is used as a correct response.

- 32** Metal thiocyanates have very different industrial uses. For example, calcium thiocyanate, $\text{Ca}(\text{NCS})_2$, is used as a stiffening agent of fabrics.

The following data is provided:

$$\Delta H_{\text{latt}}^{\ominus}(\text{Ca}(\text{NCS})_2) = -2118 \text{ kJ mol}^{-1}$$

$$\Delta H_{\text{hyd}}^{\ominus}(\text{NCS}^{-}) = -310 \text{ kJ mol}^{-1}$$

$$\Delta H_{\text{hyd}}^{\ominus}(\text{Ca}^{2+}) = -1577 \text{ kJ mol}^{-1}$$

Which of the following statements are correct?

- The magnitude of $\Delta H^{\ominus}_{\text{soln}}$ of $\text{Ca}(\text{NCS})_2$ is 79 kJ mol^{-1} .
 - Magnitude of $\Delta H^{\ominus}_{\text{latt}}$ of $\text{Ba}(\text{NCS})_2$ is smaller than that of $\text{Ca}(\text{NCS})_2$.
 - $\Delta G^{\ominus}_{\text{soln}}$ of $\text{Ca}(\text{NCS})_2$ is negative at all temperatures.
- 33** The graph below shows the variation in the standard enthalpy change of vaporisation, $\Delta H^{\ominus}(\text{vaporisation})$, for eight consecutive elements in the Periodic Table, all with atomic number, $Z \leq 20$.

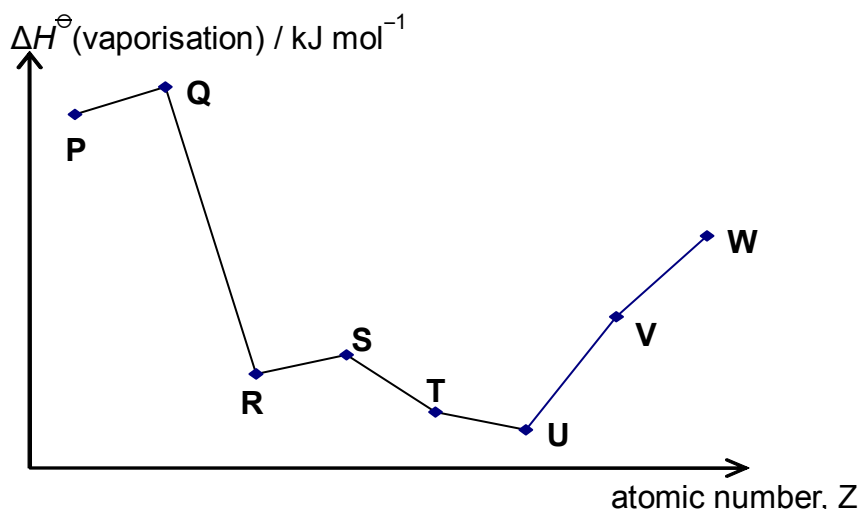

Which of the following statements are correct?

- The chloride of element **Q** is acidic in aqueous solution.
- The oxide of element **R** has a higher melting point than that of element **S**.
- Electrical conductivity decreases from element **P** to **W**.

The responses **A** to **D** should be selected on the basis of

A	B	C	D
1, 2 and 3 are correct	1 and 2 only are correct	2 and 3 only are correct	1 only is correct

No other combination of statements is used as a correct response.

- 34** A lithium-ion battery consists of: a cathode made from cobalt oxide, CoO_2 ; an anode made from graphite with lithium atoms inserted between the layers.

During discharge, Li atoms at the anode give up electrons to become Li^+ ions. The electrons travel round the external circuit, and are picked up by the cathode. A Li^+ ion from the electrolyte also moves to the cathode. This is illustrated in the following diagram in which C—C—C—C—C is a simplified representation of a layer of carbon atoms in graphite.

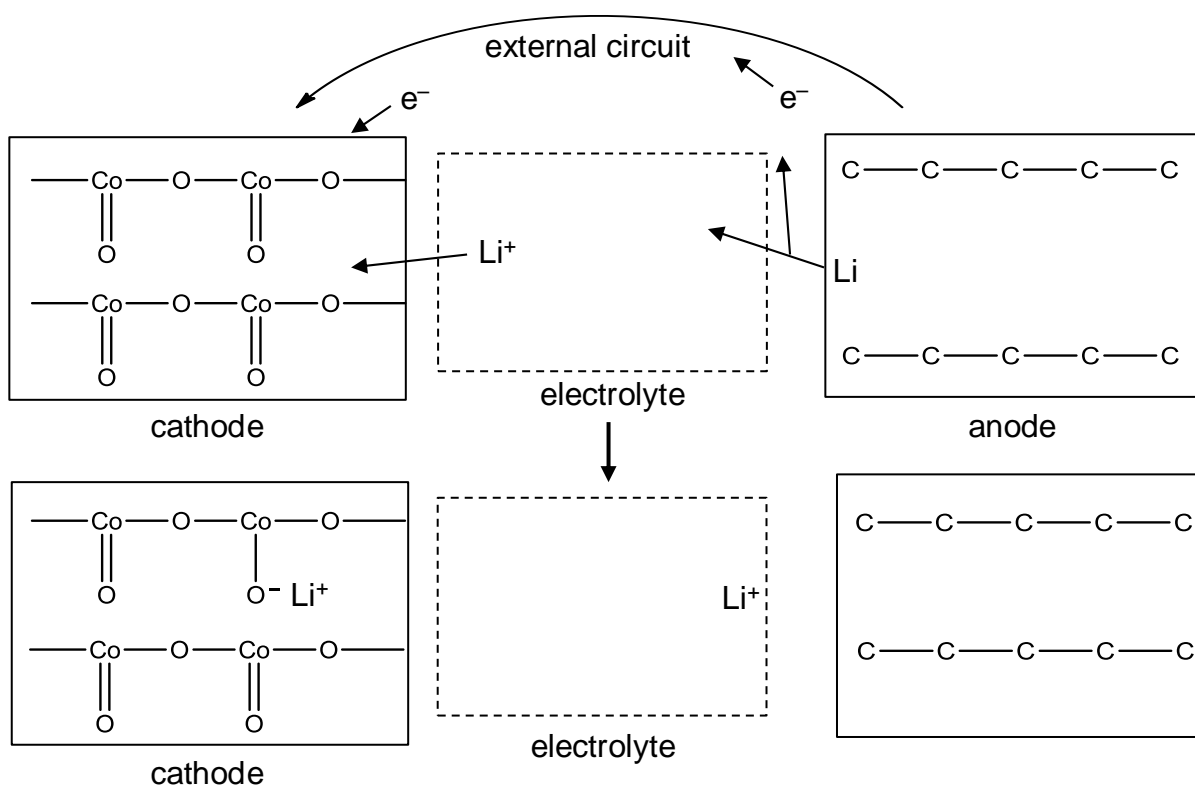

Which of the following statements are true?

- The mass of lithium metal that is deposited when a current of 3 A is passed through the battery during the charging process in 1 h 20 min is 1.03 g.
- The oxidation number of cobalt oxide cathode after discharge is +3.
- The bonding between the lithium atoms and the layers of carbon atoms is ionic in nature.

The responses **A** to **D** should be selected on the basis of

A	B	C	D
1, 2 and 3 are correct	1 and 2 only are correct	2 and 3 only are correct	1 only is correct

No other combination of statements is used as a correct response.

- 35** A chemist allowed a halogen, X_2 , to react completely with $S_2O_3^{2-}$ (aq). This resultant acidic solution was treated with an excess of aqueous barium nitrate to produce a white precipitate which is insoluble in dilute nitric acid.

Another halogen, Y_2 , gave a different sulfur-containing product with $S_2O_3^{2-}$ (aq).

Which of the following statements are correct with regards to the chemistry described?

- 1** A possible identity for X_2 is Br_2 .
- 2** A possible identity for Y_2 is I_2 .
- 3** Y_2 is a stronger oxidising agent than X_2 .

- 36** Which statements concerning the first row transition metal ions are **incorrect**?

- 1** Addition of K_2CO_3 (aq) to $CrCl_3$ (aq) produces a green precipitate of $Cr_2(CO_3)_3$.
- 2** Addition of KI (aq) to $Fe_2(SO_4)_3$ (aq) produces a brown precipitate of FeI_3 .
- 3** Addition of $NaOH$ (aq) to K_2CrO_4 (aq) produces an orange solution of $K_2Cr_2O_7$ (aq).

- 37** A catalytic converter is part of the exhaust system of modern cars.

Which reactions occur in a catalytic converter?

- 1** $2C_xH_y + (4x + y) NO \longrightarrow 2x CO_2 + y H_2O + (2x + \frac{y}{2}) N_2$
- 2** $2CO + 2NO \longrightarrow 2CO_2 + N_2$
- 3** $CO_2 + NO \longrightarrow CO + NO_2$

The responses **A** to **D** should be selected on the basis of

A	B	C	D
1, 2 and 3 are correct	1 and 2 only are correct	2 and 3 only are correct	1 only is correct

No other combination of statements is used as a correct response.

38 A non-cyclic organic compound has the molecular formula $C_5H_9O_2N$.

Which pair of functional groups could be present in this molecule?

- 1 one ketone group and one amide group
- 2 one ester group and one nitrile group
- 3 one carboxylic acid group and one nitrile group

39 *Doxorubicin* is an anti-cancer drug used to treat a wide range of cancers including blood cancers, like leukaemia and lymphoma.

[The ether group, R-O-R' is inert].

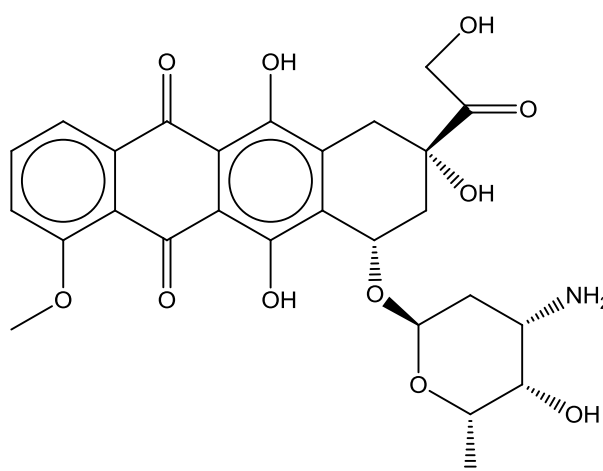

doxorubicin

Which of the following statements about *doxorubicin* are true?

- 1 Addition of sodium boron hydride causes six atoms of hydrogen to be incorporated into the molecule.
- 2 On reacting with ethanoyl chloride, six moles of ethanoyl chloride is used up per mole of *doxorubicin*.
- 3 On reacting with thionyl chloride, five moles of thionyl chloride is used up per mole of *doxorubicin*.

The responses **A** to **D** should be selected on the basis of

A	B	C	D
1, 2 and 3 are correct	1 and 2 only are correct	2 and 3 only are correct	1 only is correct

No other combination of statements is used as a correct response.

40 A reaction pathway diagram is shown.

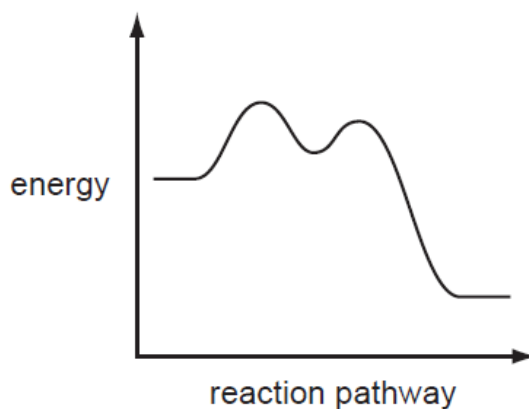

Which organic reactions could have such a profile?

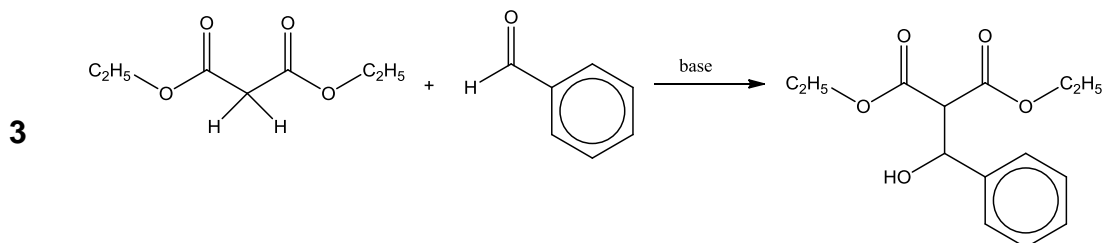
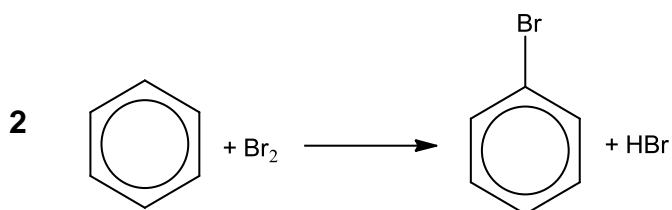
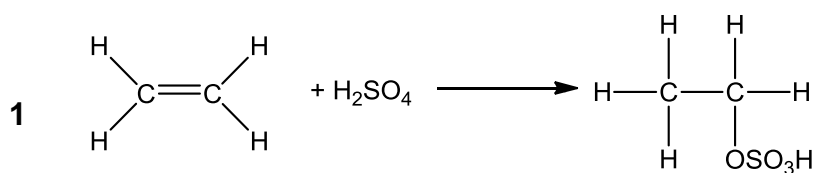

END OF PAPER

2016 MJC H2 Chemistry Prelim Paper 1 (9647/01)
Suggested Answers

Qn	Ans
1	C
2	D
3	D
4	D
5	C

6	D
7	B
8	B
9	B
10	D

Qn	Ans
11	D
12	B
13	B
14	C
15	D

16	B
17	D
18	D
19	A
20	C

Qn	Ans
21	C
22	C
23	D
24	C
25	B

26	B
27	C
28	C
29	B
30	B

Qn	Ans
31	C
32	A
33	B
34	A
35	B

36	A
37	B
38	D
39	B
40	A

Calculator Model / No.

Name: _____ Class: 15S _____ Reg Number: _____

JC2 Preliminary Examination
Higher 2

Chemistry**9647/02****Paper 2 Structured Questions****19 September 2016****2 hours**Additional Materials: *Data Booklet*

INSTRUCTIONS TO CANDIDATES

Write your name, class and register number in the spaces provided at the top of this page.

Write your calculator brand and model/number in the box provided above.

Answer **all** questions in the spaces provided on the question paper.

All working must be shown clearly.

INFORMATION FOR CANDIDATES

The number of marks is given in brackets [] at the end of each question or part question.

You are reminded of the need for good English and clear presentation in your answers.

Examiner's Use		
Paper 1	MCQ	/ 40
Paper 2	Q1	/ 12
	Q2	/ 17
	Q3	/ 15
	Q4	/ 9
	Q5	/ 7
	Q6	/ 12
	Total	/ 72
Paper 3		/ 80
Total		/ 192
Percentage		
Grade		

This document consists of **28** printed pages

1 Planning (P)

Lead iodide, PbI_2 , is a sparingly soluble salt.

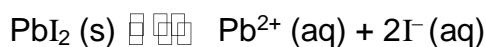

One method of determining the relative solubility and an approximate value of the solubility product of the salt, K_{sp} , would be through direct observation. Two standard solutions (one of a soluble lead(II) salt, and the other of a soluble iodide salt) in different proportions are mixed and allowed to stand and reach an equilibrium. In some mixtures, the ionic product of the particular solution exceeds the K_{sp} value and precipitation of PbI_2 crystals will occur. In other mixtures, the final concentrations of lead and iodide ions will be such that precipitation does not occur.

The experimental ionic product can be determined for each solution. In the experiment, the value of K_{sp} lies between the ionic product values for solutions with precipitate and those values for solutions without precipitate. The value for K_{sp} can be given as:

$$\begin{array}{l} \textit{Maximum} \text{ ionic product} \\ \text{that does not gives } ppt \end{array} < K_{\text{sp}} < \begin{array}{l} \textit{Minimum} \text{ ionic product} \\ \text{that gives } ppt \end{array}$$

The value for K_{sp} can be estimated by determining the mean between the above two ionic products. In order for a more precise determination of K_{sp} , the concentration of the solution mixtures should be prepared in a manner that would result in a relatively small range of ionic products.

In the experiment, two standard solutions of lead(II) nitrate and potassium iodide are prepared and then diluted appropriately using relevant volumes of the solutions and water. To avoid localised supersaturation that brings about erroneous precipitation, water has to be mixed in first.

In order to predetermine the concentrations required, a student prepared two solutions, **A** and **B**.

Solution A contains 2.50 cm³ of 0.0100 mol dm⁻³ lead(II) nitrate, $\text{Pb}(\text{NO}_3)_2$ with 5.50 cm³ of deionised water added.

Solution B contains 2.00 cm³ of 0.0100 mol dm⁻³ potassium iodide, KI.

Mixing these above solutions (at 25°C) produced the yellow precipitate of PbI_2 . These solutions provide an ionic product which **just exceeds** the K_{sp} of PbI_2 .

- (a) Calculate the ionic product of PbI_2 in this given mixture to determine a rough estimate of the K_{sp} value of PbI_2 .

[1]

- (b) Consider the description of the precipitation experiment given in this question.

Write a plan for such a series of **four** experiments to determine a value for the K_{sp} of PbI_2 . In your plan, you should use the same total volume as described when solutions **A** and **B** are mixed.

Your plan should ensure that

- at least two of your experiments do not produce a precipitate
- the estimated range for the value of K_{sp} is relatively small. ($< 10\%$ deviation from the estimated ionic product in (a)).

You should use the quantities specified in (a) in one of your experiments.

You may assume that you are provided with

- solid lead nitrate, $\text{Pb}(\text{NO}_3)_2$
- $0.0400 \text{ mol dm}^{-3}$ aqueous potassium iodide, KI,
- deionised water,
- the equipment and materials normally found in a school or college laboratory.

Your plan should include the following.

- details, including quantities, for the preparation of a 100 cm^3 stock solution of $0.0100 \text{ mol dm}^{-3}$ of $\text{Pb}(\text{NO}_3)_2$
- details, including quantities for the preparation of a 100 cm^3 stock solution of $0.0100 \text{ mol dm}^{-3}$ of KI
- suitable format summarising appropriate quantities of solutions to be used in each experiment (for four experiments), the corresponding concentrations and calculated ionic products
- outline of all essential experimental procedures
- brief, but specific details on how the K_{sp} value can be estimated from the experiment.

[8]

- (c) Explain how the solubility of PbI_2 would change if PbI_2 is dissolved in a solution of hydroiodic acid, HI.

[1]

- (d) Lead(II) salts are toxic and prolonged exposure affects the mental development in children. Pb^{2+} ions can be removed from contaminated water through precipitation by adding a soluble salt solution containing the appropriate anion.

The solubility products of some sparingly soluble lead(II) salts, at 25 °C are given in the table below.

Salt	K_{sp}
PbCO_3	$7.4 \times 10^{-14} \text{ mol}^2 \text{ dm}^{-6}$
$\text{Pb}(\text{IO}_3)_2$	$3.7 \times 10^{-13} \text{ mol}^3 \text{ dm}^{-9}$
$\text{Pb}_3(\text{PO}_4)_2$	$7.9 \times 10^{-43} \text{ mol}^5 \text{ dm}^{-15}$

Calculate the solubility of the above lead(II) salts in mol dm^{-3} at 25°C. Hence, state the most effective anion in removing Pb^{2+} from the contaminated water sample.

[2]

[Total: 12]

- 2 Amines are a class of compounds that are widely used in both the pharmaceutical and agricultural industry. An amine-containing drug, *Tamiflu* is an effective drug against the H1N1 strain of influenza A virus. Another amine, ethylamine, $\text{CH}_3\text{CH}_2\text{NH}_2$, is widely used in the production of herbicides.

- (a) In order to determine the standard enthalpy change of neutralisation, 60.0 cm^3 of $0.370 \text{ mol dm}^{-3}$ aqueous ethylamine was placed in a polystyrene cup. Dilute HCl was added and after each addition, the mixture was stirred and the temperature noted.

The highest temperature reached was recorded and plotted on the graph below.

Graph of temperature of mixture against volume of HCl added

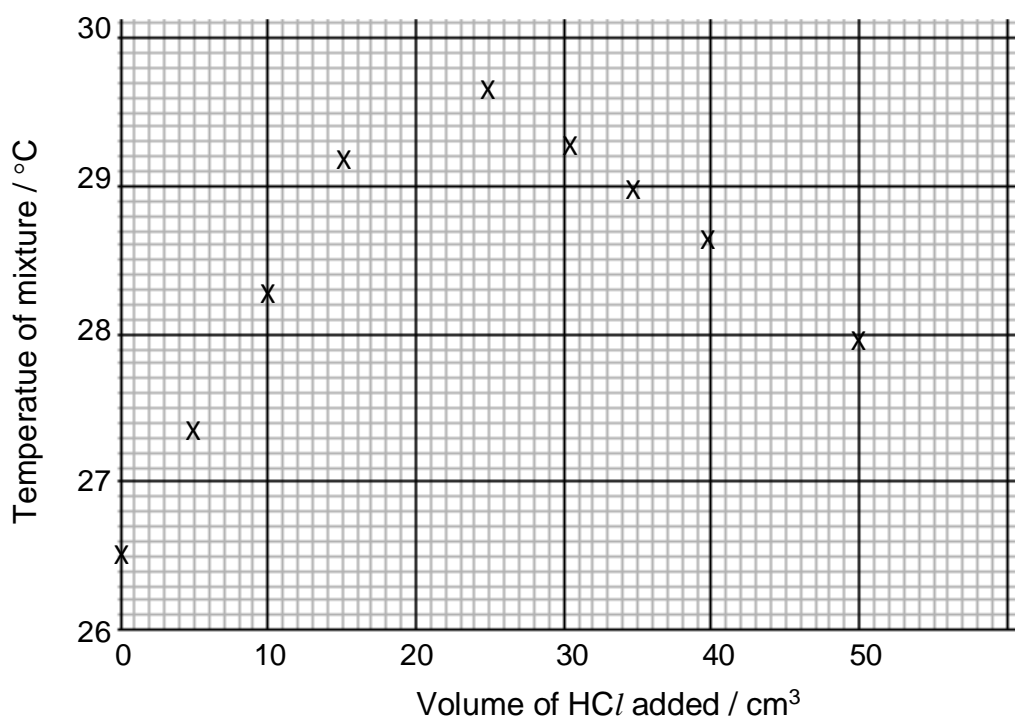

- (i) Calculate the initial pH of aqueous ethylamine in the polystyrene cup.

Base dissociation constant of ethylamine is $5.6 \times 10^{-4} \text{ mol dm}^{-3}$.

[1]

(ii) Calculate the concentration of dilute HCl used in the experiment. [1]

(iii) Calculate the enthalpy change of neutralisation for the reaction between HCl and ethylamine.

(You may assume the density of the solutions is 1.00 g cm^{-3} and their specific heat capacity is $4.18 \text{ J g}^{-1} \text{ K}^{-1}$.)

[2]

(iv) With reference to your answer in (a)(iii), explain why the temperature of the mixture was reported to be higher when the above experiment was repeated using an aliquot of aqueous potassium hydroxide of the same concentration as that of the ethylamine sample.

[1]

- (b) In another experiment, a sample of $0.640 \text{ mol dm}^{-3}$ aqueous ethylamine was added to 10.0 cm^3 dilute HNO_3 in a conical flask. The equivalence point can be detected by a distinct colour change brought about by the use of a suitable indicator.

The graph below shows the change in pH of the reaction mixture against the volume of ethylamine added.

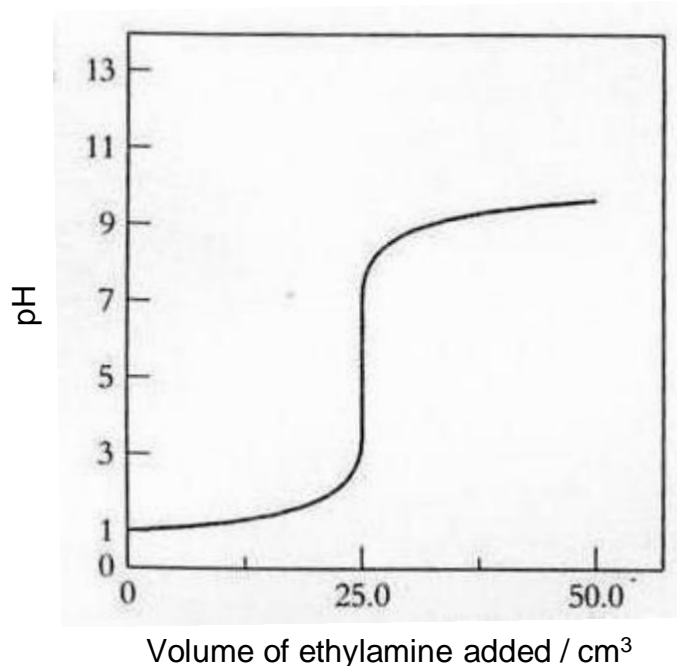

- (i) Suggest a suitable indicator for this acid–base titration and state the colour change observed at the equivalence point. [1]

Indicator: _____

Colour change: _____

- (ii) Circle clearly on the graph, the region within which the mixture is acting as a buffer. [1]

- (iii) Write an equation to suggest how the solution in (b) (ii) acts a buffer upon the addition of a small amount of aqueous sodium hydroxide. [1]

- (c) An agricultural chemist synthesised ethylamine from ethanal in an industrial laboratory via a two-step procedure as shown in the scheme below.

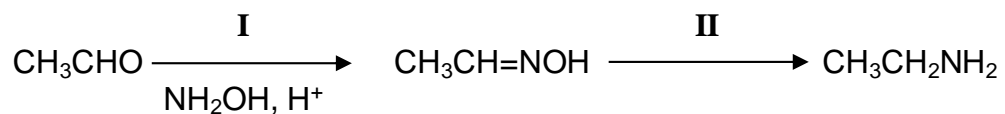

- (i) Suggest the type of reactions for both steps and the reagents and conditions for step II.

[2]

Step	Type of reaction	Reagents and conditions
I		
II		

- (ii) Suggest a chemical test that the chemist can perform to confirm that the procedure is complete.

[1]

- (d) Use the following data and relevant data from the *Data Booklet* to construct an energy cycle to calculate the enthalpy change of formation of $\text{CH}_3\text{CH}_2\text{NH}_2(l)$.

Enthalpy change of vapourisation of $\text{CH}_3\text{CH}_2\text{NH}_2(l) = +29 \text{ kJ mol}^{-1}$

Enthalpy change of atomisation of $\text{C}(s) = +715 \text{ kJ mol}^{-1}$

[3]

- (e) The structure of *Tamiflu* is shown below.

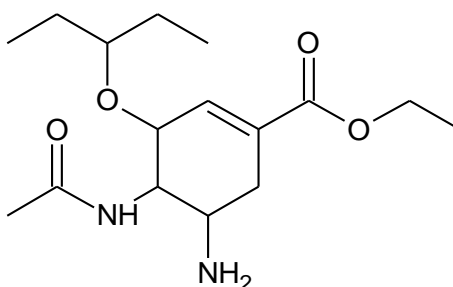

- (i) Name the two nitrogen-containing functional groups present in *Tamiflu*.

[1]

- (ii) Compound **Q** is a derivative of *Tamiflu* while compound **R** is an aromatic compound with similar functional groups as *Tamiflu*.

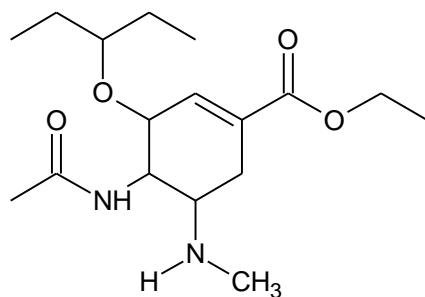

compound **Q**

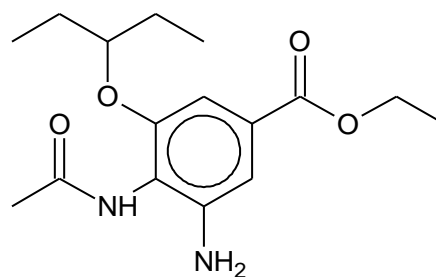

compound **R**

Describe and explain the relative basicities of the following compounds:

- Compound **Q** and *Tamiflu*

[1]

- Compound **R** and *Tamiflu*

[1]

3 Halogens have a wide range of uses, such as in water purification and as antiseptics. Halogens form compounds, such as halides and oxoanions which are used in photography and as oxidising agents respectively.

(a) When potassium iodide reacts with concentrated sulfuric acid, violet vapour is observed and a pungent gas is detected.

(i) Write a chemical equation for the reaction to account for the formation of the violet vapour.

[1]

(ii) When potassium bromide reacts with concentrated sulfuric acid, different observations are made.

By quoting suitable values from the *Data Booklet*, explain the difference in the observations.

[2]

(iii) In order to prepare HBr as the only bromine-containing product from KBr, concentrated H_3PO_4 should be used instead of concentrated H_2SO_4 .

Suggest a plausible reason for this. Write a balanced equation for this reaction.

[2]

(b) Precipitates are formed when aqueous silver nitrate is added to separate tubes containing aqueous potassium chloride, aqueous potassium bromide and aqueous potassium iodide.

(i) Describe the effect of adding concentrated NH_3 to **each** of the resulting mixtures.

[1]

Tube containing KCl _____

Tube containing KBr _____

Tube containing KI _____

(ii) Provide a qualitative explanation to substantiate your answer for observations in the tube containing KI .

[2]

- (c) 5.0×10^{-4} mol of a bromate salt containing the BrO_4^{n-} anion was added to 20.0 cm^3 of acidified KI present in excess to yield iodine and bromide ions. The remaining solution was made up to 250 cm^3 with distilled water.

A 25.0 cm^3 aliquot of the resultant solution required 40.0 cm^3 of $0.010 \text{ mol dm}^{-3}$ sodium thiosulfate, $\text{Na}_2\text{S}_2\text{O}_3$, for complete reaction.

Calculate the value of n .

[2]

(d) When heated in chlorine, magnesium forms magnesium chloride. Magnesium can also be heated in air to give magnesium oxide. Similarly, aluminium and zinc can be vapourised and reacted with air to form the respective oxides.

(i) Describe the reactions, if any, of magnesium chloride and magnesium oxide with water, suggesting the pH of the resulting solutions and writing equations where appropriate.

[3]

(ii) Zinc oxide has acid–base properties that are similar to aluminium oxide. Write equations for **two** reactions which demonstrate these properties of zinc oxide.

[2]

[Total: 15]

- 4 The *Williamson* reaction is widely used in the laboratory and industrial synthesis of ethers. It is the simplest and most popular method of preparing ethers.

In a typical *Williamson* reaction, an alkoxide ion is prepared *in situ* and is reacted with a halogenoalkane according to the general equation shown below.

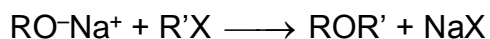

where R,R' are alkyl groups and X is Br or Cl.

The following experimental procedure details the synthesis of (3-methylbutoxy)benzene using the *Williamson* reaction.

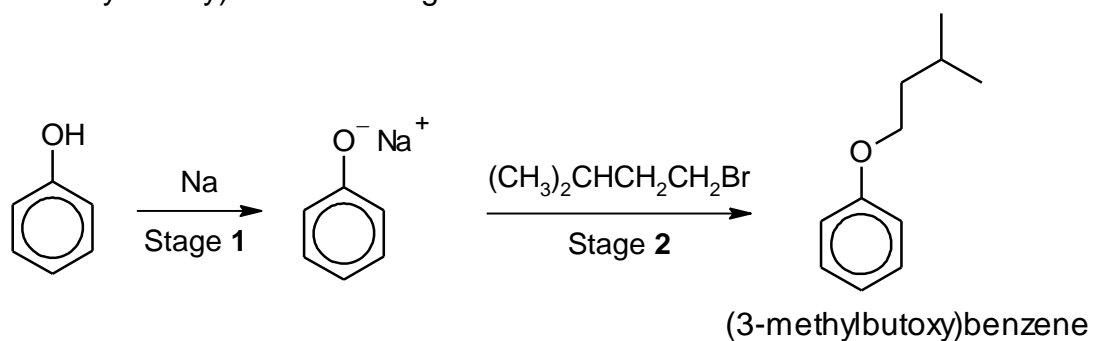

PROCEDURE:

Preparation of (3-methylbutoxy)benzene

- 1 2.90 g of sodium metal is added to a dry round-bottom flask equipped with a dropping funnel and a condenser. This apparatus set-up is shown below. The set-up is protected from atmospheric moisture with the use of a calcium chloride guard tube.

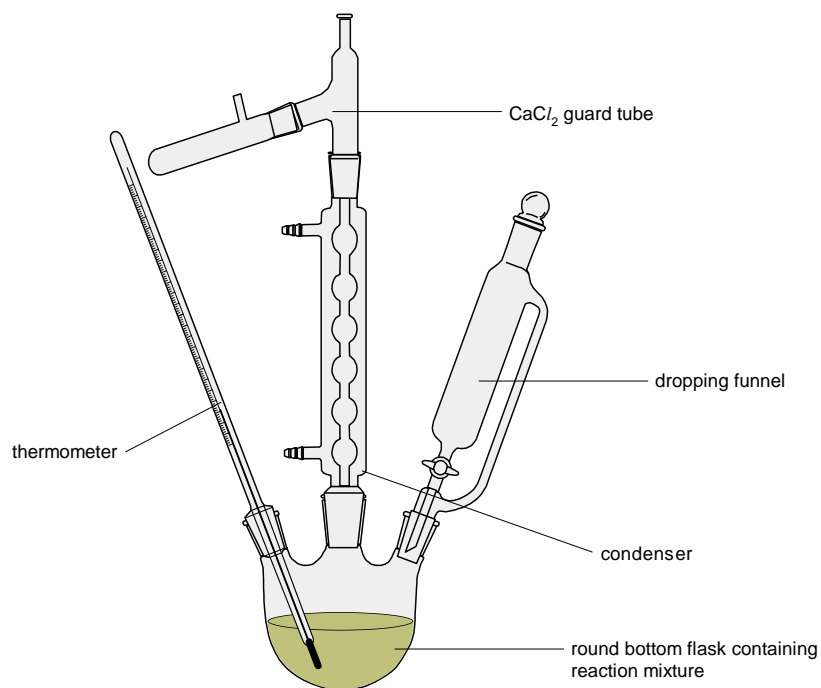

- 2 Prepare an ethanolic solution containing 11.8 g of phenol. Add dropwise to the reaction mixture using the dropping funnel. If the reaction becomes too vigorous, cool the flask with a cold towel until the reaction is again under control.
- 3 Transfer 20.0 cm³ of 1-bromo-3-methylbutane to the dropping funnel and add it to the flask slowly over 3 – 4 minutes.
- 4 Boil the reaction mixture gently over a water bath for 30 minutes.
- 5 Evaporate as much of the ethanol solvent as possible.

Purification of (3-methylbutoxy)benzene

- 6 Add about 20 cm³ of water to the residue in the flask and separate the organic layer using a separating funnel.
- 7 Wash the organic layer with sodium hydroxide.
- 8 Then, wash the organic layer with dilute sulfuric acid and water again.
- 9 Add anhydrous magnesium sulfate to the organic layer.
- 10 Distill the organic layer to purify (3-methylbutoxy)benzene at a suitable temperature.

Table 4: Physical Properties of the reagents and the organic product

substance	formula	molar mass / g mol ⁻¹	physical state at r.t.p.	density / g cm ⁻³	solubility in water	boiling point / °C
ethanol	C ₂ H ₅ OH	46	liquid	0.789	soluble	78
phenol	C ₆ H ₅ OH	94	solid	1.07	insoluble	182
1-bromo-3-methylbutane	C ₅ H ₁₁ Br	151	liquid	1.21	insoluble	120
(3-methylbutoxy)benzene	C ₁₁ H ₁₆ O	164	liquid	0.91	insoluble	216
sodium bromide	NaBr	103	solid	3.21	soluble	–
water	H ₂ O	18	liquid	1.00	–	100

- (a) (i) Suggest why it is necessary to protect the apparatus set-up from moisture using the calcium chloride guard tube in step 1.

[1]

- (ii) Determine the theoretical yield (in g) of (3-methylbutoxy)benzene for this reaction. You may assume that the reaction between sodium and phenol to form phenoxide in stage 1 is complete.

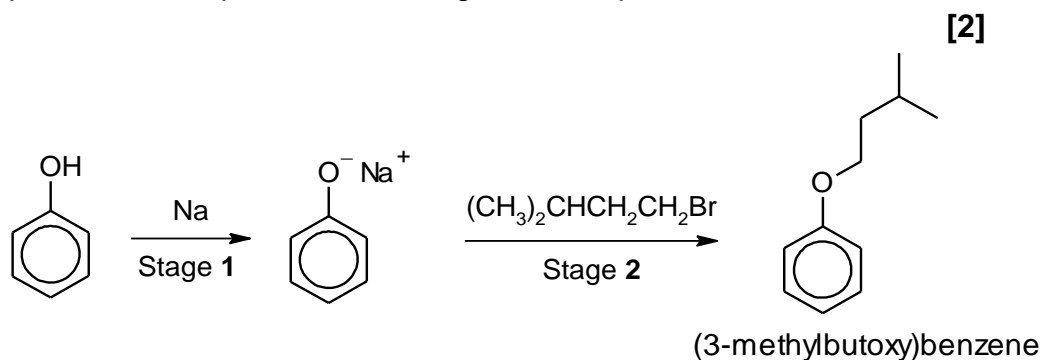

- (iii) On the diagram of the separating funnel below, label the two layers that will be observed after step 6.

[1]

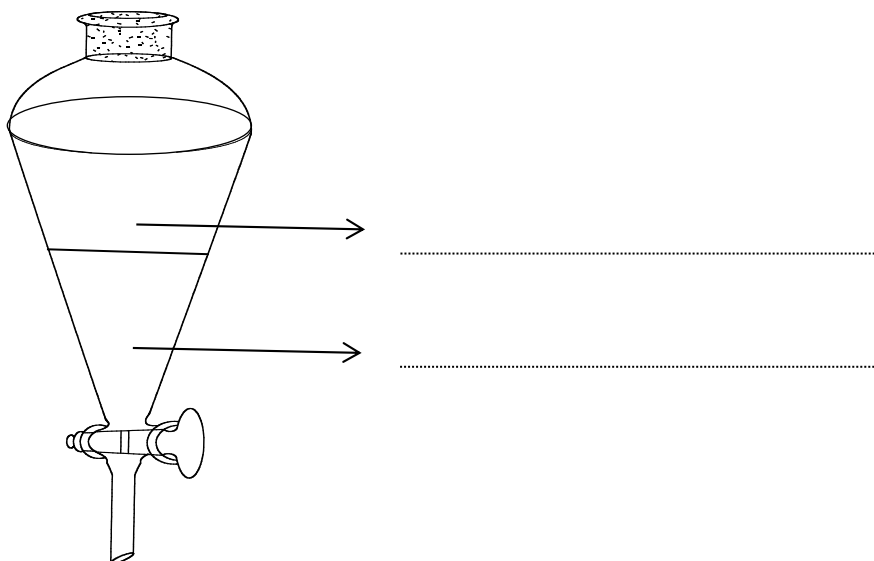

- (b) Other than the crude product, the organic layer (Step 6) also contains several impurities. These impurities comprises of unreacted reactants, by-products or products from undesired reactions.

In the purification of the crude product (Steps 6 – 9), the impurities are removed from the crude product with each subsequent addition of chemicals.

- (i) Suggest the impurity removed by each of the chemicals below.

[1]

1 sodium hydroxide _____

2 anhydrous magnesium sulfate _____

- (ii) With reference to the data provided in **Table 4**, account for the observed boiling points of ethanol and the product, (3-methylbutoxy)benzene.

In your answer, you should state the predominant type of interactions present in the two compounds.

[2]

- (iii)** The final stage in the purification process is the distillation of the crude product (Step **10**).

Suggest why distillation is a suitable technique to obtain a pure sample of (3-methylbutoxy)benzene. Propose a suitable range of temperature for the distillation set-up.

[2]

[Total: 9]

- 5 On 21st April 2016, famed American pop artiste, Prince Rogers Nelson died of an accidental overdose of the drug, *fentanyl*.

Fentanyl, an opioid analgesic was first synthesised in 1960. It was primarily used for pain relief in clinical practice. Its efficacy is about 100 times that of *morphine*.

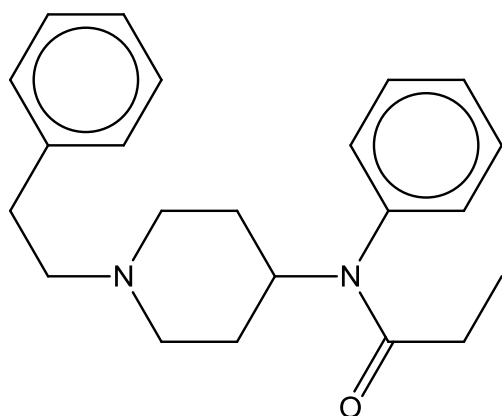

Fentanyl

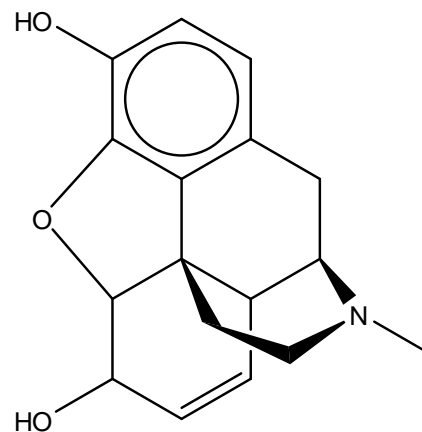

Morphine

Fentanyl can be synthesised from 2-bromoethylbenzene following the reaction scheme below.

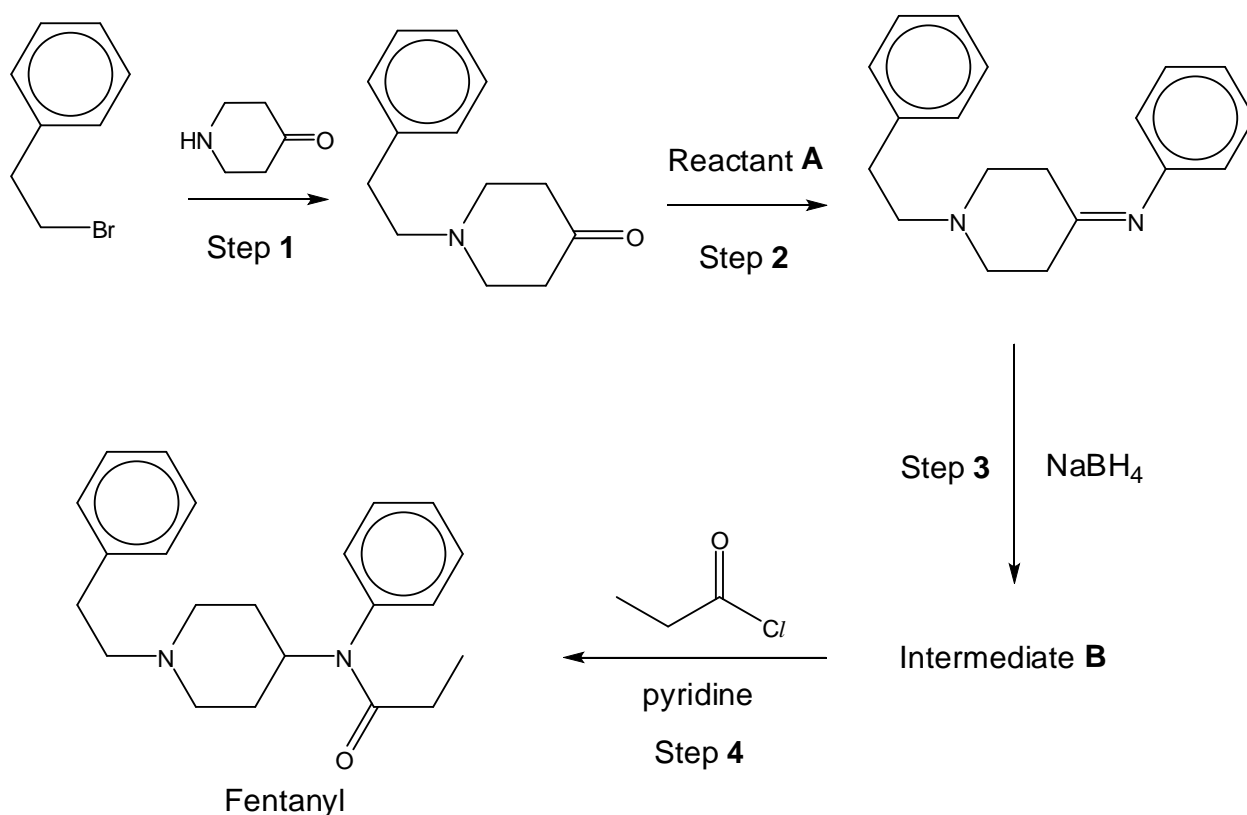

- (a) Name and outline the mechanism for the reaction in step 1. Show relevant lone pairs and dipoles, and use curly arrows to indicate the movement of electron pairs.

[2]

- (b) Suggest the displayed formula of reactant **A** in Step 2.

[1]

- (c) Propose the structure of intermediate **B**.

[1]

(d) Propanyl chloride is used in step **4** in the synthesis of *fentanyl*.

Explain why the use of propanoic acid as a replacement in step **4** is not suitable.

[1]

(e) Suggest a chemical test that can be used to distinguish between *fentanyl* and *morphine*.

[2]

[Total: 7]

6 Copper forms compounds with variable oxidation states and these compounds are used in numerous industries such as in wastewater treatment and as mineral supplements.

(a) The following scheme illustrates the reactions between different compounds of copper.

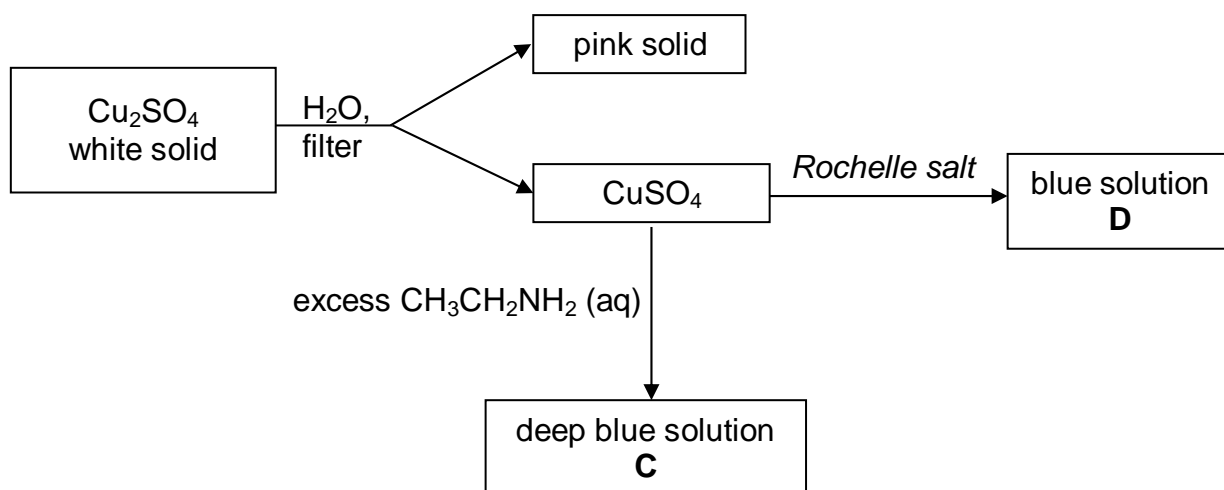

(i) State the full electronic configuration of copper in the white solid.

[1]

(ii) With reference to relevant E^\ominus data from the *Data Booklet*, describe and explain the type of reaction undergone when the white solid dissolves in water.

[2]

- (iii) Identify the species in solution **C** that is responsible for the deep blue colour and account for its formation from CuSO_4 . Include a relevant equation in your answer.

[2]

- (iv) Solution **D** is formed when *Rochelle salt* (an aqueous solution of potassium sodium tartrate $\text{KNaC}_4\text{H}_4\text{O}_6$) is mixed with a solution of CuSO_4 in basic medium.

Use the following data to determine the chemical formula of the copper tartrate anion complex.

- The composition by mass of the elements is
Cu: 17.76 % C: 26.85% H: 1.68% O: 53.71%
- The chemical formula takes the form of $[\text{ML}_2]^{n-}$.

[2]

- (b) Copper(II) ions are commonly used as *homogeneous catalysts* in the removal of harmful cyanide ions, CN^- from wastewater by hydrogen peroxide to form the less harmful cyanate CNO^- ions as illustrated in the following reaction.

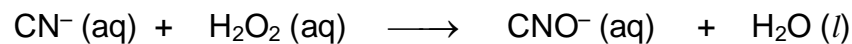

By considering relevant E^\ominus values from the *Data Booklet*, explain how copper(II) ions act as *homogeneous catalyst* in this reaction, writing balanced equations where appropriate.

[3]



- (c) When aqueous glycine solution is added to a heated ethanolic solution of copper(II) ethanoate, light blue needles of a planar, neutral copper–glycinate complex is obtained upon cooling.

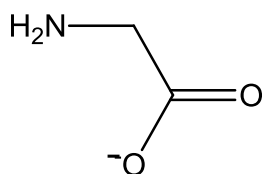

glycinate ion

- (i) Draw the three-dimensional structure of the copper–glycinate complex ion.

[1]

- (ii) State the type of isomerism exhibited by the copper–glycinate complex ion.

[1]

[Total: 12]

END OF PAPER

2016 MJC Prelim P2 Suggested Answers

1 Planning (P)

(a) Ionic product = $(2.50 \times 10^{-3})(2.00 \times 10^{-3})^2 = \underline{1.00 \times 10^{-8} \text{ mol}^3 \text{ dm}^{-9}}$. *Show working to consider total volume is different.*

(b) Preparation of $0.01 \text{ mol dm}^{-3} \text{ Pb(NO}_3)_2$ standard solution (100 cm^3)

- 1) Weigh a clean, dry empty weighing bottle using a mass balance.
- 2) Weigh out approximately 0.331 g of solid $\text{Pb(NO}_3)_2$.
- 3) Transfer the solid into a clean 100 cm^3 beaker and reweigh the weighing bottle with the residue to determine the exact mass of $\text{Pb(NO}_3)_2$ used.
- 4) Dissolve the solid carefully with some deionised water and transfer it into a 100 cm^3 volumetric flask.
- 5) Top up the flask to the mark with deionised water, stopper and mix well to obtain a homogeneous solution.

Dilution of KI standard solution (100 cm^3)

- 1) Pipette 25.0 cm^3 of given $0.0400 \text{ mol dm}^{-3} \text{ PbI}_2$ solution into a 100 cm^3 volumetric flask.
- 2) Top of top the mark with deionised water, stopper and mix well.

Possible quantities and concentrations of solutions to be used (4 expt sets)

Expt	Vol. of Pb^{2+} / cm^3	Vol of I^- / cm^3	Vol of H_2O / cm^3	$[\text{Pb}^{2+}]_{(\text{mixture})}$ / mol dm^{-3}	$[\text{I}^-]_{(\text{mixture})}$ / mol dm^{-3}	Ionic product of PbI_2
5	2.50	2.00	5.50	0.00250	0.00200	$y_1: 1.00 \times 10^{-8}$
6	1.00	3.00	6.00	0.00100	0.00300	$y_2: 9.00 \times 10^{-9}$
7	2.00	2.00	6.00	0.00200	0.00200	8.00×10^{-9}
8	1.50	2.00	6.50	0.00150	0.00200	6.00×10^{-9}
9	1.00	1.00	8.00	0.00100	0.00100	1.00×10^{-9}

Experimental procedure

- 1) Fill three 50.00 cm^3 burettes with the prepared $0.0100 \text{ mol dm}^{-3} \text{ Pb(NO}_3)_2$ stock solution, $0.0100 \text{ mol dm}^{-3} \text{ KI}$ stock solution and deionised water respectively.
- 2) Run out 1.00 cm^3 of deionised water and 5.00 cm^3 of KI into a 100 cm^3 conical flask / beaker.
- 3) Run out 4.00 cm^3 of $\text{Pb(NO}_3)_2$ into the conical flask / beaker and swirl the flask well / stir with a glass rod.
- 4) Allow the flask / beaker to stand undisturbed for at least 30 min to attain equilibrium.

- 5) Note if any precipitate of yellow PbI_2 is present on standing.
- 6) Repeat the experiment using the various volumes shown in table (*Total volume = 10.00 cm³ / constant*).
- 7) Estimated $K_{\text{sp}} = \frac{y_1 + y_2}{2}$ where y_1 : *minimum ionic product with precipitation* and y_2 : *maximum ionic product without precipitation*.

(c) Solubility would decrease.

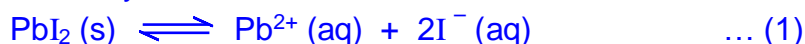

Due to presence of common ion (I^{-}), equilibrium position of (1) shifts left.

(d)

<i>Salt</i>	<i>Solubility</i>
PbCO_3	$s^2 = 7.4 \times 10^{-14}$ Solubility = $s = 2.72 \times 10^{-7} \text{ mol dm}^{-3}$
$\text{Pb}(\text{IO}_3)_2$	$4s^3 = 3.7 \times 10^{-13}$ Solubility = $s = 4.52 \times 10^{-5} \text{ mol dm}^{-3}$
$\text{Pb}_3(\text{PO}_4)_2$	$108s^5 = 7.9 \times 10^{-43}$ Solubility = $s = 1.49 \times 10^{-9} \text{ mol dm}^{-3}$

Most effective: PO_4^{3-}

2(ai) $[\text{OH}^{-}] = \sqrt{0.370 \times 5.6 \times 10^{-4}} = 0.01439 \text{ mol dm}^{-3}$
 $\text{pOH} = -\lg 0.01439 = 1.84$ hence $\text{pH} = \underline{12.2}$

(ii) No. of mole of ethylamine = $0.370 \times \frac{60}{1000} = 0.0222$

$$[\text{HC}] = \frac{0.0222}{\frac{20}{1000}} = 1.11 \text{ mol dm}^{-3}$$

(iii) Heat absorbed by solution = $80 \times 4.18 \times 3.5 = 1170 \text{ J}$

$$\text{No. of moles of H}_2\text{O produced} = 0.370 \times \frac{60}{1000} = 0.0222$$

$$\text{Enthalpy change of neutralisation} = -\frac{1170}{0.0222} = \underline{-52.7 \text{ kJ mol}^{-1}}$$

(iv) Some energy evolved from the neutralisation process is used to further dissociate the weak base completely

(bii)

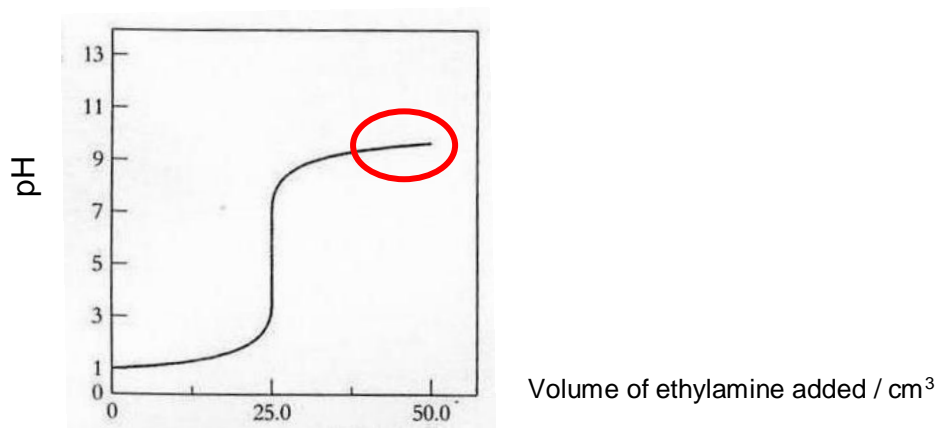

(bi) Methyl orange . Red to orange.

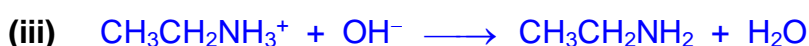

(ci)

Step	Type of reaction	Reagents and conditions
I	condensation	
II	reduction	LiAlH ₄ in dry ether

(ii) Add 2,4-DNPH to sample and heat. Synthesis is complete when no orange ppt is observed. *Accept other possible tests.*

(d)

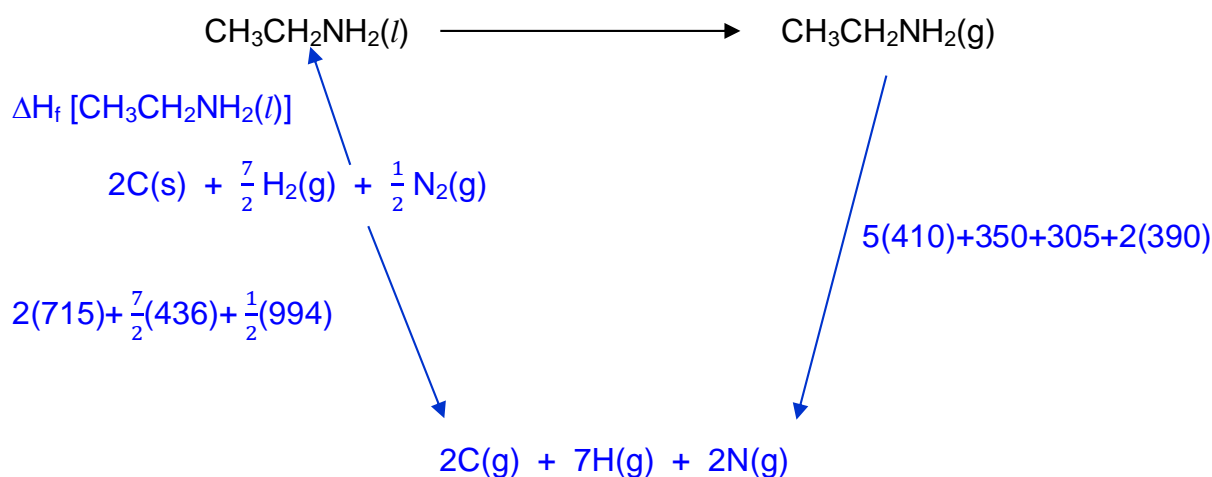

$$\begin{aligned} \Delta H_f [\text{CH}_3\text{CH}_2\text{NH}_2(l)] + 29 + 3485 &= 3453 \\ \Delta H_f [\text{CH}_3\text{CH}_2\text{NH}_2(l)] &= \underline{\underline{-61.0 \text{ kJ mol}^{-1}}} \end{aligned}$$

(ei) amide, amine

- (ii) Compound **Q** is more basic than Tamiflu. The electron-donating R group increases the electron density of the lone pair on N atom hence more available to accept a proton. Compound **R** is less basic. The lone pair of electron on N atom is delocalised into the benzene ring hence less available to accept a proton.



- (ii) $E^\ominus = +0.54 \text{ V}$ and $E^\ominus = +1.07 \text{ V}$. As $E^\ominus_{\text{Br}_2/\text{Br}^-}$ is more positive than $E^\ominus_{\text{I}_2/\text{I}^-}$, Br^- is a weaker reducing agent than I^- .

- (iii) Conc. H_3PO_4 is a weaker oxidising agent than conc. H_2SO_4
 $\text{KBr}(\text{s}) + \text{H}_3\text{PO}_4(\text{l}) \longrightarrow \text{HBr}(\text{g}) + \text{KH}_2\text{PO}_4(\text{s})$

- (bi) KCl : ppt dissolves
 KBr : ppt dissolves
 KI : ppt does not dissolve

- (ii) NH_3 ligand combines with $\text{Ag}^+(\text{aq})$ to form diamminesilver(I) complex or $[\text{Ag}(\text{NH}_3)_2]^+$. Ionic product (of $[\text{Ag}^+][\text{I}^-]$ easily) exceed the low K_{sp} value hence thus AgI does not dissolve.

- (c) Number of mole of iodine in 25.0cm^3 aliquot = $\frac{1}{2} \times (0.0400 \times 0.010)$
 Number of mole of iodine in $250 \text{ cm}^3 = 2.00 \times 10^{-3}$

$$\frac{n_{\text{I}_2}}{n_{\text{BrO}_4^{n-}}} = \frac{2 \times 10^{-3}}{5 \times 10^{-4}} = 4$$



$$+7 + 4(-2) = n(-1)$$

$$\underline{n = 1}$$

- (di) $\text{MgCl}_2(\text{s}) + 6\text{H}_2\text{O}(\text{l}) \longrightarrow [\text{Mg}(\text{H}_2\text{O})_6]^{2+}(\text{aq}) + 2\text{Cl}^-(\text{aq})$
 $[\text{Mg}(\text{H}_2\text{O})_6]^{2+}(\text{aq}) \rightleftharpoons [\text{Mg}(\text{H}_2\text{O})_5(\text{OH})]^+(\text{aq}) + \text{H}^+(\text{aq})$ pH = 6.5



- (ii) $\text{ZnO} + 2\text{HCl} \longrightarrow \text{ZnCl}_2 + \text{H}_2\text{O}$
 $\text{ZnO} + 2\text{NaOH} + \text{H}_2\text{O} \longrightarrow \text{Na}_2\text{Zn}(\text{OH})_4$

4(ai) Prevent the moisture from reacting with the sodium metal.

(ii) No. of moles of phenol = $(11.8 / 94) = 0.1255$ (same as phenoxide)

No. of moles of 1-bromo-3-methylbutane = $(20.0 \times 1.21) / 151$

Mass of (3-methylbutoxy)benzene = $0.1255 \times 164 = \underline{20.6 \text{ g}}$

(iii)

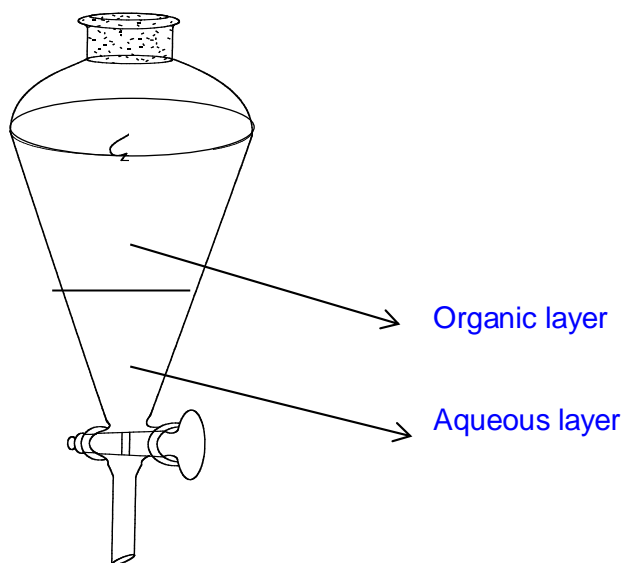

(bi) **1** (unreacted) phenol ; **2** water

(ii) (3-methylbutoxy)benzene has a higher boiling point. The extensive van der Waals' forces of attraction between 3-methylbutoxy)benzene molecules is stronger than the hydrogen bonding in ethanol.

(iii) Boiling point of the (3-methylbutoxy)benzene is significantly higher than the other impurities. Temperature range is from 214 °C - 218 °C.

5(a) S_N2

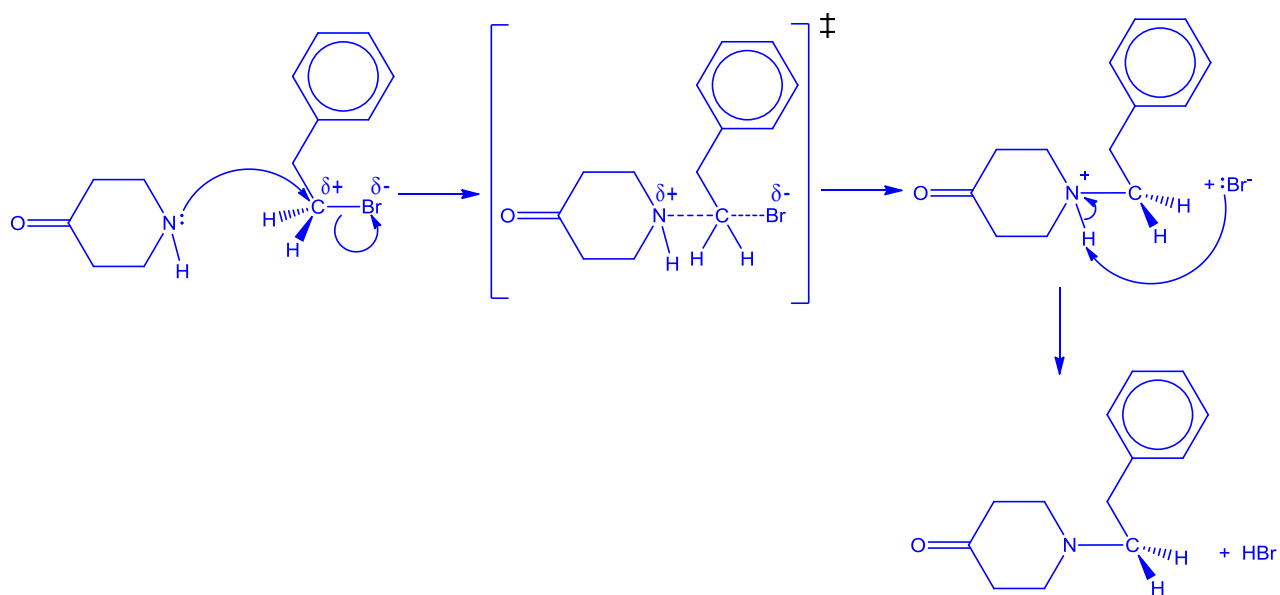

(b)

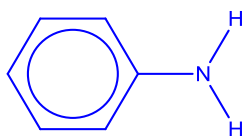

(c)

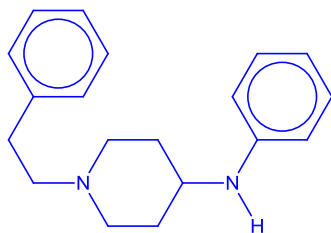

(d) Carboxylic acid will undergo acid-base reaction with the amine groups instead.

(e) Add aqueous neutral iron (III) chloride. For morphine, a violet complex observed but not for fentanyl. *Accept other tests.*

6(ai) $1s^2 2s^2 2p^6 3s^2 3p^6 3d^{10}$

(ii) $E^\ominus_{\text{cell}} = 0.52 - 0.15 = +0.37 > 0$. Hence, Cu^+ disproportionates into pink solid Cu and blue solution of Cu^{2+} .

(iii) The stronger $\text{CH}_3\text{CH}_2\text{NH}_2$ ligands replace H_2O ligands to form a deep blue complex $[\text{Cu}(\text{CH}_3\text{CH}_2\text{NH}_2)_4(\text{H}_2\text{O})_2]^{2+}$.



(iv)

	Cu	C	H	O
% by mass	17.76	26.85	1.68	53.71
No. of moles	$\frac{17.76}{63.5}$	$\frac{26.85}{12.0}$	$\frac{1.68}{1.0}$	$\frac{53.71}{16.0}$
Simplest ratio	1	8	6	12

Chemical formula of anion is $[\text{Cu}(\text{C}_4\text{H}_3\text{O}_6)_2]^{4-}$

(b) $E^\ominus_{\text{cell}} = 0.15 - (-0.97) = +1.12 \text{ V} > 0$ hence reaction is feasible.



$E^\ominus_{\text{cell}} = 1.77 - 0.15 = +1.62 \text{ V} > 0$ hence reaction is feasible.

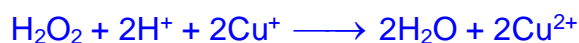

(ci)

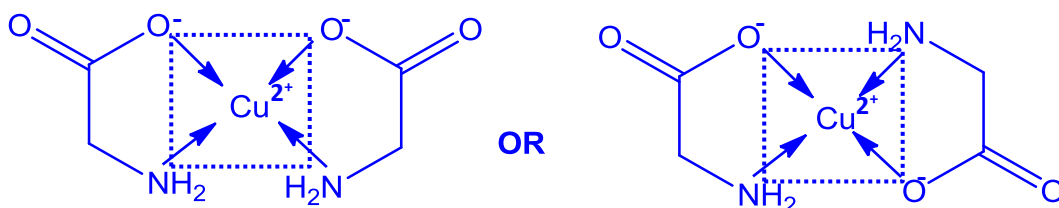

(ii) Cis-trans isomerism

Calculator Model / No.

Name: _____ Class: 15S _____ Reg Number: _____

**JC2 Preliminary Examination
Higher 2**

Chemistry

9647/03

Paper 3 Free Response

14 September 2016

2 hours

Additional Materials: *Data Booklet*
 Writing Paper

INSTRUCTIONS TO CANDIDATES

Write your name, class and register number in the spaces provided at the top of this page.

Answer 4 out of 5 questions in this paper.

Begin each question on a fresh sheet of writing paper.

Fasten the writing papers behind the given **Cover Page for Questions 1 & 2** and **Cover Page for Questions 3, 4 & 5** respectively.

Hand in Questions **1 & 2** and **3, 4 & 5** separately.

You are advised to spend about 30 minutes per question only.

INFORMATION FOR CANDIDATES

The number of marks is given in brackets [] at the end of each question or part question.

You are reminded of the need for good English and clear presentation in your answers.

This document consists of **18** printed pages.

[Blank Page]

Answer any 4 out of 5 questions in this paper.

*Begin each question on a **fresh sheet** of writing paper.*

- 1 Benzyl halides are colourless liquids that have been used in chemical warfare due to their ability to cause severe eye, respiratory and skin irritation. Benzyl halides are also used in organic synthesis for the introduction of the benzyl protecting group for alcohols and carboxylic acids.

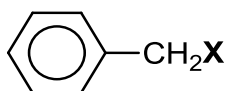

benzyl halide

- (a) Benzyl iodide, $C_6H_5CH_2I$ can be synthesised from benzene in a **four** step pathway involving Friedel–Crafts alkylation. Friedel–Crafts alkylation involves the alkylation of a benzene ring in the presence of a suitable catalyst via electrophilic substitution.

Outline this synthesis route, suggesting relevant reagents, conditions and intermediate products.

[4]

- (b) Another method to synthesise benzyl iodide is via the *Finkelstein reaction*, which involves the conversion of benzyl bromide to benzyl iodide using stoichiometric amounts of potassium iodide under reflux conditions.

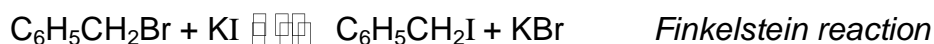

The rate equation is $\text{rate} = k [C_6H_5CH_2Br]$.

- (i) Draw diagrams to illustrate the mechanism for this reaction. Show relevant lone pairs and dipoles, and use curly arrows to indicate the movement of electron pairs.

[2]

- (ii) Suggest a plausible chemical test that can be performed on a sample of the reaction mixture to test whether the reaction is effectively complete.

[2]

- (iii) Explain why benzyl bromide undergoes a unimolecular reaction with $KI(aq)$ whereas (2-bromoethyl)benzene, $C_6H_5CH_2CH_2Br$, undergoes a bimolecular reaction with $KI(aq)$.

[1]

- (c) The *Finkelstein reaction* proceeds at a faster rate in the presence of polar solvents such as propanone, CH_3COCH_3 . The increase in rate lies in the difference in solubility between KI and KBr in propanone.

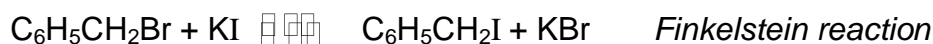

Potassium halides	Solubility in propanone
KI	Very soluble
KBr	Almost insoluble

- (i) Suggest why the *Finkelstein reaction* goes almost to completion. [1]
- (ii) In the solvation process, one potassium ion interacts with six propanone molecules. Draw a diagram to show how this interaction forms an octahedral unit. State clearly the type of interaction involved. [2]
- (iii) Suggest why potassium bromide is less soluble than potassium iodide in propanone by considering the lattice energy of the potassium halides and enthalpy change of solvation of the halides ions. [1]
- (d) Benzyl iodides are widely used in complex organic synthesis to form benzyl ethers ($\text{C}_6\text{H}_5\text{CH}_2\text{O-R}$), which are good blocking groups that protect alcohol functional groups from further reactions. These blocking groups are inert to hydrolysis under normal conditions, but they can be removed at the end of the reaction via the addition of an appropriate hydrogen halide molecule to obtain the original functional group and regenerate the benzyl iodide.

The following illustrates a synthetic scheme from compound **W** in which a benzyl ether is acting as the protecting group.

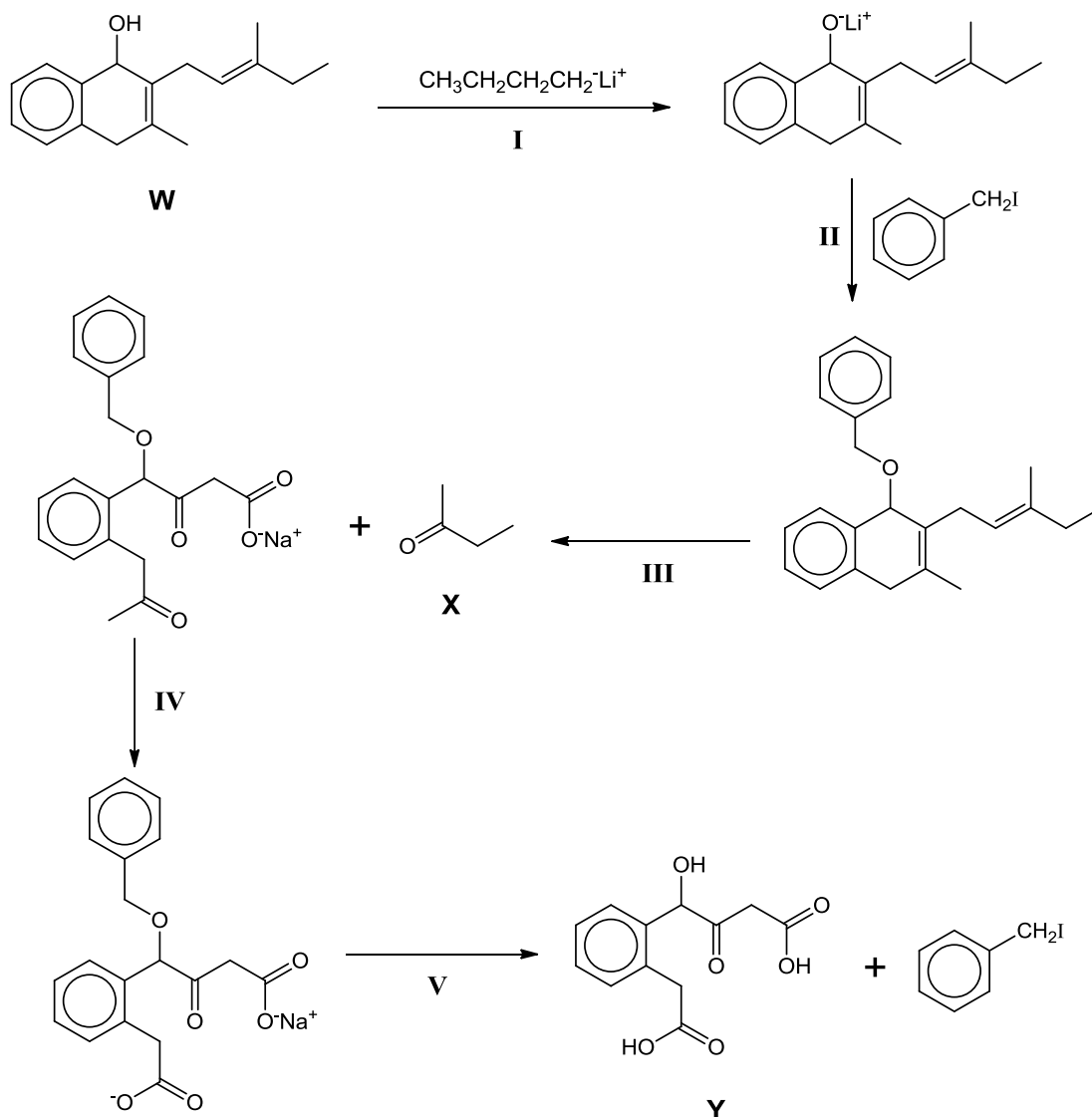

- (i) State the role of $\text{CH}_3\text{CH}_2\text{CH}_2\text{CH}_2^- \text{Li}^+$ in step I. [1]
- (ii) Predict with reasoning, the relative rate of the reaction in Step II when the reactant used is benzyl bromide, $\text{C}_6\text{H}_5\text{CH}_2\text{Br}$ instead of benzyl iodide, $\text{C}_6\text{H}_5\text{CH}_2\text{I}$. Quote relevant values from the *Data Booklet* to substantiate your answer. [2]
- (iii) State the reagents and conditions needed for steps III, IV and V. [3]
- (iv) Write a balanced equation for the reaction between compound **X** and 2,4-dinitrophenylhydrazine. [1]

[Total: 20]

- 2 (a) Zinc–air batteries have received revived interest recently due to its higher energy density, larger storage capacity and lower production cost as compared to the commonly–used conventional lithium–ion batteries.

During discharge, oxygen from the air oxidises zinc to zinc oxide. The electrolyte used in the battery is KOH (aq). The zinc–air battery has a standard cell potential of +1.59 V.

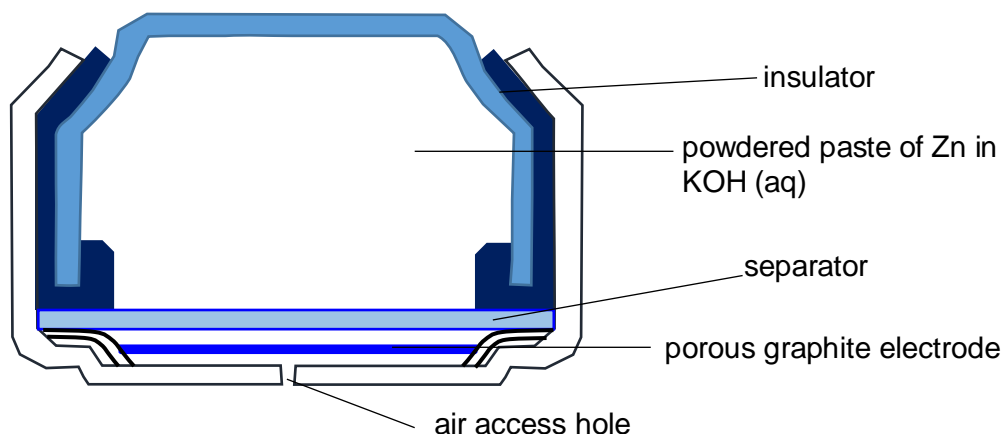

- (i) Construct equations for the reactions which occur at the anode and cathode. Hence, construct the overall equation for the cell reaction. [2]
- (ii) Using suitable data from the *Data Booklet*, calculate the value for the E^\ominus of the ZnO / Zn electrode reaction. [1]
- (iii) Suggest a reason why the air–access hole of these zinc–air batteries must be well–sealed during the packaging of these batteries for storage. [1]
- (iv) With reference to your answer in (a)(i), explain fully why the operating cell potential of the zinc–air batteries becomes less positive at high altitudes where the atmospheric pressure is lowered. [2]
- (v) Determine the current output (in amperes) of this zinc–air battery given that the air–access holes allow about 0.20 dm³ of air exchange in 1 hour at room temperature and pressure. You may assume that the percentage of O₂ present in air is 21.0%. [2]

(b) Carbon dioxide, when present in sufficient concentration in air, may result in the formation of insoluble zinc carbonate that clogs the porous graphite electrode. This hinders the normal operation of the battery.

(i) Write an equation with state symbols for the thermal decomposition of zinc carbonate.

[1]

(ii) Zinc carbonate and barium carbonate decompose when heated to give similar products.

By quoting appropriate data from the *Data Booklet*, deduce whether zinc carbonate would decompose at a higher or lower temperature than barium carbonate. Explain your answer.

[2]

(iii) Using the following data and relevant data from the *Data Booklet*, construct a Born–Haber cycle to calculate the lattice energy of zinc carbonate.

standard enthalpy change of atomisation of Zn (s) = + 131 kJ mol⁻¹

standard enthalpy change of formation of CO₃²⁻ (g) = - 321 kJ mol⁻¹

standard enthalpy change of formation of ZnCO₃ (s) = - 818 kJ mol⁻¹

[3]

(c) Zinc exhibits some properties that are similar to those of a transition element. For example, zinc metal has demonstrated its potential as a *heterogeneous* catalyst for the acylation of a large variety of phenols with acyl chlorides.

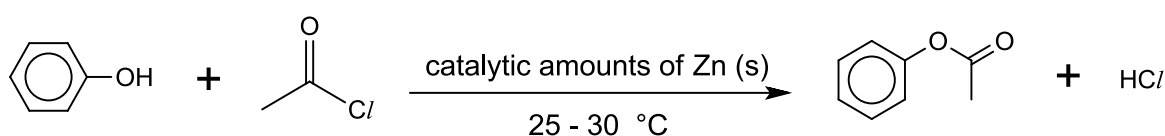

Describe fully how zinc functions as a catalyst for this reaction.

[3]

(d) Similar to aluminium, zinc can be anodised to make it more resistant to corrosion. Draw a fully labelled diagram and with the aid of equation(s), explain how zinc can be anodised.

[3]

[Total: 20]

- 3 *Atorvastatin* has been a very popular drug since 1996. It is consumed to reduce blood cholesterol level and for prevention of heart diseases.

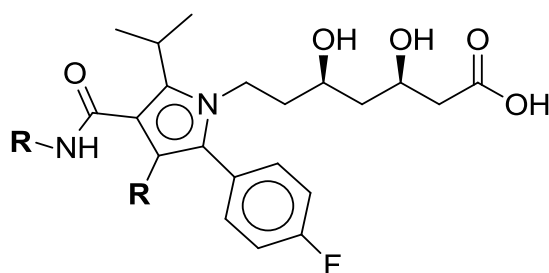

Atorvastatin

R is a hydrocarbon group

- (a) A sample of 1 g of *atorvastatin* was completely burnt in excess oxygen and 103.7 cm³ of NO₂ gas was produced. All volumes were measured at 80 °C and 1 atm.
- (i) Calculate the M_r of *atorvastatin*, to the nearest whole number, using the above information. [2]
- (ii) The actual M_r of *atorvastatin* is 558. Explain why there is a discrepancy between the calculated M_r in (a)(i) and the actual M_r . [2]
- (b) *Atorvastatin* is sold as the calcium salt in tablet form. Each tablet contains 40 mg of the calcium salt. The maximum dosage is 80 mg per day for an average 65 kg adult.



- (i) Use of information in the photograph above is relevant to this question.

Calculate the minimum number of bottles of tablets a patient needs to stock up for a year, assuming that he adheres strictly to the daily dosage limit and consumes it every day.

[1]

- (ii) Using structure and bonding, explain the differences in solubility of *atorvastatin* and *atorvastatin calcium* in CCl_4 .

[2]

In pharmaceutical companies, *atorvastatin* can be synthesised by reacting compound **A** with compound **C**.

- (c) Compound **A** is made from smaller molecules. The following reaction scheme shows the synthesis of compound **A**.

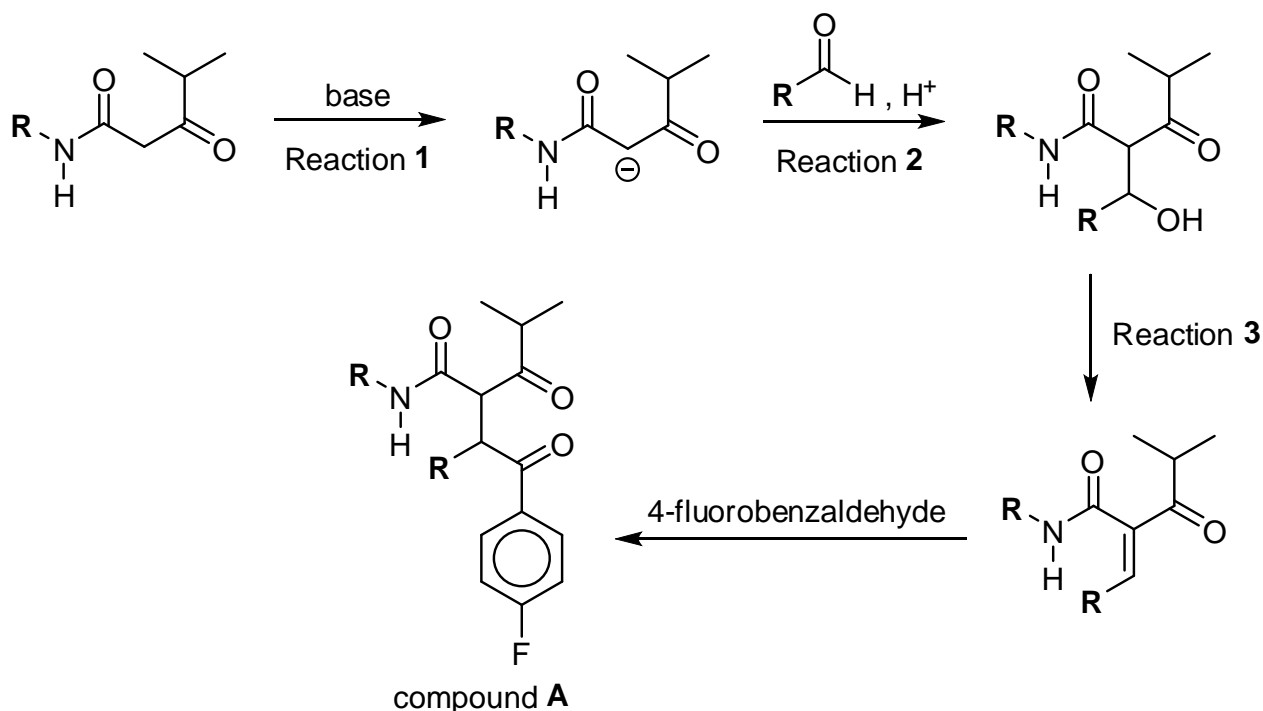

Reaction **1**, **2** and **3** are part of an aldol condensation reaction. A brief description of each reaction is given below.

Reaction **1**: The carbonyl α -carbon is deprotonated.

Reaction **2**: Nucleophilic addition takes place on the carbonyl compound.

Reaction **3**: Elimination of the alcohol forms an alkene which is conjugated to the ketone.

- (i) Outline the mechanism for Reaction **2**. Show relevant lone pairs and dipoles, and use curly arrows to indicate the movement of electron pairs.

[2]

- (ii) Using the information in the reaction scheme given, suggest the products formed, **D** and **E**, when the following carbonyl compounds undergo aldol condensation reaction in the presence of a base.

[2]

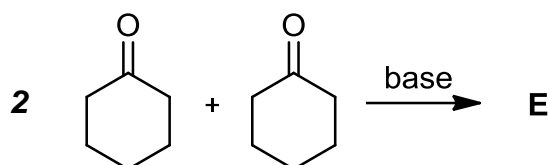
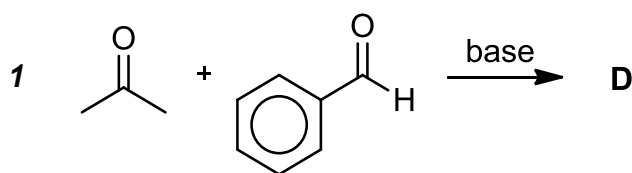

- (d) The following reaction scheme shows the synthesis of compound **C**.

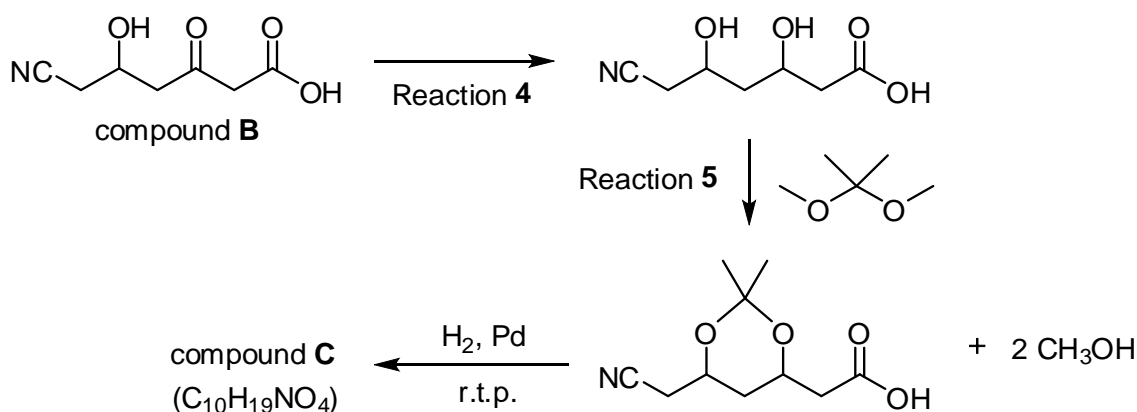

- (i) State the reagent and condition for Reaction 4. [1]
- (ii) Suggest the type of reaction in Reaction 5. [1]
- (iii) Draw the structure of compound **C**. [1]
- (iv) Compound **B** forms a cyclic product, with the loss of one water molecule, when it is heated with concentrated sulfuric acid. Suggest the structure of the product formed. [1]

[1]

- (e) The following reaction scheme shows the final steps in the production of *atorvastatin*.

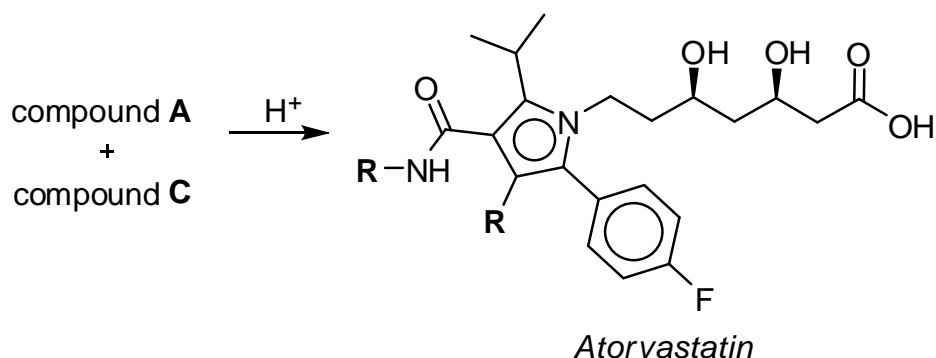

Atorvastatin contains several functional groups.

- (i) It has **two different** acidic functional groups. Name them and explain why one has a higher K_a value than the other.

[3]

- (ii) The nitrogen atom in the five-membered ring is basic. Draw the structures of the products formed when *atorvastatin* is heated with acidified potassium dichromate(VI).

[2]

[Total: 20]

- 4 Adipic acid is an organic compound with the formula $(\text{CH}_2)_4(\text{COOH})_2$. It is the most important of the dicarboxylic acids from the industrial perspective. Approximately 2.5 billion kilograms of this white crystalline powder are produced annually, predominantly as a precursor for the production of nylon 66.

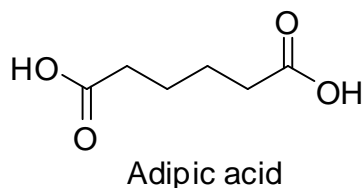

- (a) One method to synthesis adipic acid is by the carbonylation of gaseous 1,3-butadiene with carbon monoxide and steam.

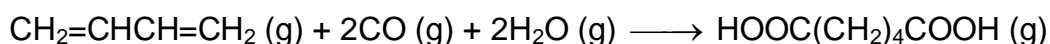

- (i) Use relevant bond energy data from the *Data Booklet* to calculate the enthalpy change for this reaction.

(Given that bond energy of $\text{C}\equiv\text{O}$ is 1079 kJ mol^{-1})

[2]

- (ii) The enthalpy change for the following reaction to form adipic acid in the solid form is -248 kJ mol^{-1} .

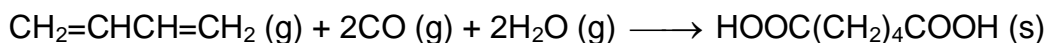

Account for the differences in the values for (a)(i) and (a)(ii).

[1]

- (iii) It is also possible to synthesise adipic acid by reacting adipoyl dichloride through a hydrolysis reaction with water.

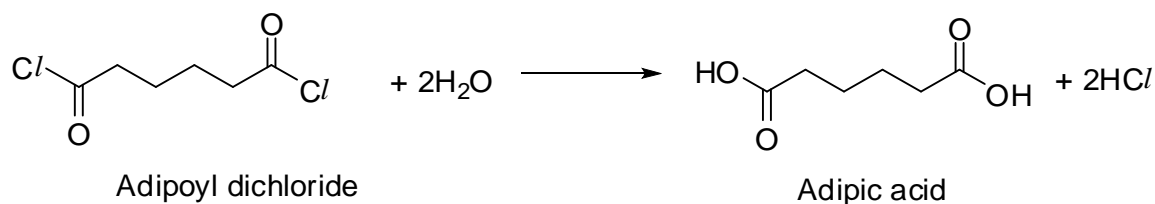

Describe and explain the relative ease of hydrolysis of adipoyl dichloride and compound **A** shown below.

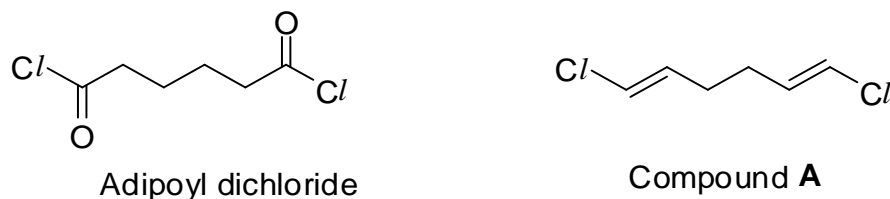

[2]

(b) Adipic acid and its calcium salt are used as a buffer solution to remove sulfur dioxide from exhaust flue gases of fossil-fuel power plants. Calcium sulfate, CaSO_4 is formed at the end of the reaction.

(i) Draw the dot-and-cross diagram for the ion, SO_4^{2-} .

[1]

(ii) In principle, $\text{S}_2\text{O}_8^{2-}$ can be formed from the oxidation of SO_4^{2-} .

Draw the structure of $\text{S}_2\text{O}_8^{2-}$, given that there are four central atoms and that the ion is symmetrical with an O–O bond.

Account for its shape with respect to **each different** central atom using the VSEPR theory.

[3]

(iii) Adipic acid is a dibasic acid with $\text{p}K_a$ values of 4.4 and 5.4.

The optimal buffer pH for the adipic acid–calcium salt mixture is 4.6. Calculate the volume of 0.1 mol dm^{-3} of calcium hydroxide that needs to be added to 500 cm^3 of 0.01 mol dm^{-3} of adipic acid to yield the optimal buffer solution.

[3]

(c) Compound **B** has the same molecular formula, $\text{C}_6\text{H}_{10}\text{O}_4$ as adipic acid. **B** is a neutral molecule but reacts with hot aqueous sulfuric acid to yield two organic compounds **C**, $\text{C}_4\text{H}_{10}\text{O}_2$ and **D** in a 1:1 ratio.

Compound **C** contains 2 chiral carbon atoms. Compound **C** forms no precipitate with 2,4–dinitrophenylhydrazine but reacts with hot aluminium oxide to form only three isomers **E**, **F** and **G** with the molecular formula of $\text{C}_4\text{H}_8\text{O}$. **Only** isomer **G** rotates the plane of polarised light.

Compound **D** reacts with hot alkaline Cu^{2+} solution to give a red precipitate. It also reacts with hot acidified KMnO_4 to form effervescence of carbon dioxide.

(i) Suggest structures for compounds **B**, **C**, **D**, **E**, **F** and **G**, showing your reasoning clearly.

[7]

(ii) Write a balanced chemical equation for the reaction between **D** and hot alkaline Cu^{2+} solution.

[1]

[Total: 20]

5 *Hemocyanin* and *chymotrypsin* are proteins used for various functions.

Hemocyanin is a copper-containing oxygen transport protein found in marine invertebrates such as squids. Its mode of transport of oxygen is similar to that of *haemoglobin*. In *hemocyanin*, oxygen is transported in the form of oxyhemocyanin.

(a) Describe what is meant by the *quaternary* structure of *hemocyanin*.

[1]

(b) In squids, one molecule of *hemocyanin* (Hc) binds to one molecule of oxygen via the oxygenation process, according to the following equation:



(i) In squid *hemocyanin*, when the partial pressure of oxygen gas is 0.13 atm at 25°C, the oxygen-binding sites are 33.0% saturated.

Calculate the equilibrium constant, K_c , at this temperature.

[2]

(ii) The Gibbs free energy change at 25°C when *hemocyanin* interacts with $\text{O}_2 \text{ (g)}$ is related to the equilibrium constant using the following equation.

$$\Delta G = -RT \ln K_c$$

Calculate the Gibbs free energy change.

[1]

(iii) It is claimed that “*global warming would harm aquatic organisms such as the squid population*”, through adversely affecting the oxygenation of squid *hemocyanin*.”

Verify this claim by considering the signs of the ΔH and ΔS of the oxygenation process.

[2]

(iv) The blood of the squid is blue in colour as oxygenation causes a colour change between the colourless Cu(I) deoxygenated form of *hemocyanin* to the blue Cu(II) oxygenated form.

Explain why the oxygenated Cu(II) form of *hemocyanin* is blue in colour.

[3]

Chymotrypsin is an enzyme produced by the pancreas that is responsible for catalysing the hydrolysis of certain proteins in the small intestine during the digestive process. Part of the structure of *chymotrypsin* is given below along with the abbreviated names of its constituent amino acids: **gly**, **leu**, etc.

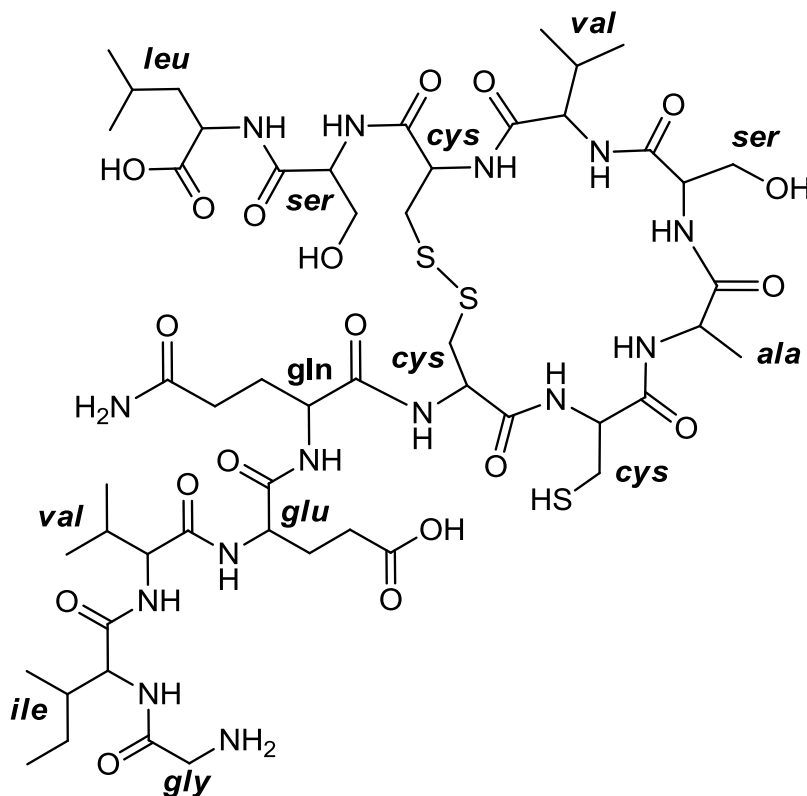

(c) Use the abbreviated names of the amino acids to state the primary structure of the fragment of *chymotrypsin* given above.

[2]

(d) The biological function of *chymotrypsin* depends on its three-dimensional shape. Describe how the particular amino acids in *chymotrypsin* are likely to be involved in maintaining its three-dimensional shape.

[2]

(e) The activity of *chymotrypsin* is inhibited by prolonged heating with sodium hydroxide.

Draw the structure of the tripeptide obtained under these conditions from the part of *chymotrypsin* containing the amino acids: **ile**–**val**–**glu**.

[2]

- (f) *Chymotrypsin* undergoes denaturation by sodium hydroxide, with the mechanism dependent on pH. At high pH, the reaction is first order with respect to both the *chymotrypsin* and hydroxide ions.

In an experiment, the denaturation of the enzyme was monitored in the presence of excess alkali.

The plot of the time course of the reaction is shown below.

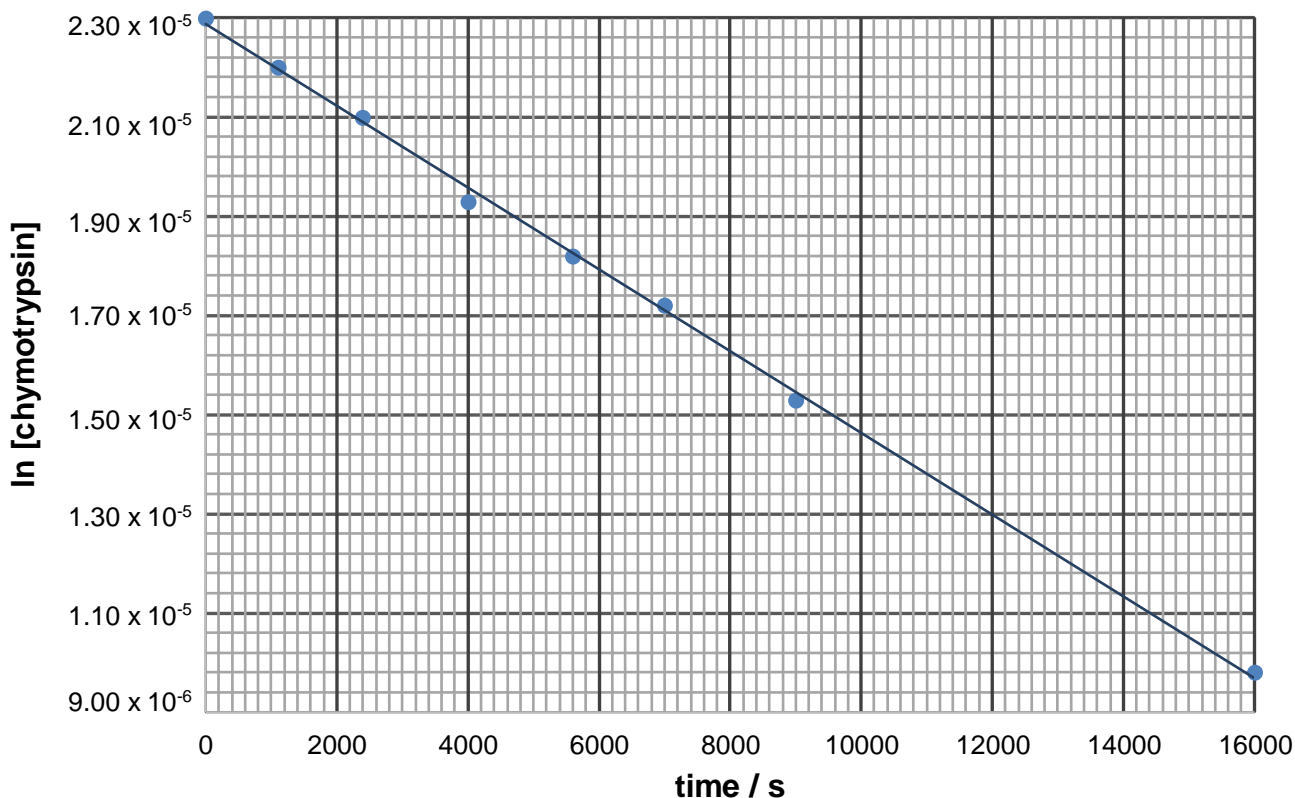

The rate law can be expressed in the form of:

$$\ln[A] = -kt + \ln[A]_0$$

where $[A]$ = concentration of a reactant at time, t

$[A]_0$ = initial concentration of that reactant

t = time since the reaction started

k = rate constant

- (i) Explain how the plot of the time course of the reaction confirms that the denaturation is first order with respect to *chymotrypsin* and how the conditions give rise to overall first order kinetics.

[1]

- (ii) Using the plot of the time course of the reaction, calculate the value of the experimentally-determined rate constant of this denaturation.

[1]

(iii) Hence, calculate the value of the true rate constant, given that concentration of NaOH used in the experiment was 1.5 mol dm^{-3} .

[1]

(g) One of the amino acids involved in the catalytic activity of *chymotrypsin* is aspartic acid.

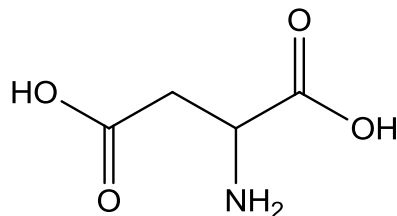

Aspartic acid

There are three pK_a values associated with aspartic acid: 2.1, 3.9 and 9.8.

Suggest the predominant species present in solutions of aspartic acid with the following pH values of:

(i) 2.4

(ii) 7.0

[2]

[Total: 20]

END OF PAPER

2016 MJC Prelim Paper 3 Suggested Answers

1(a)

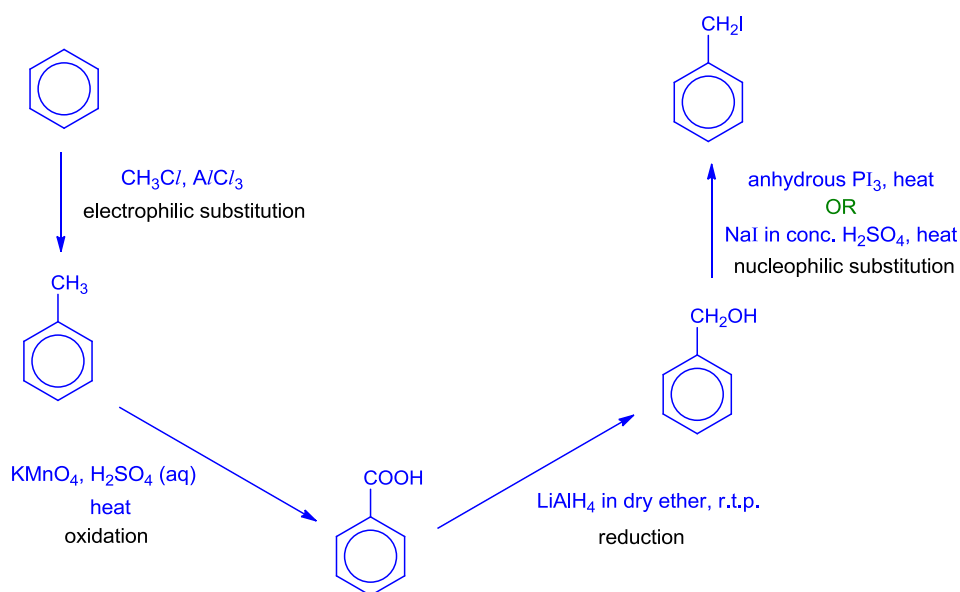

(b)

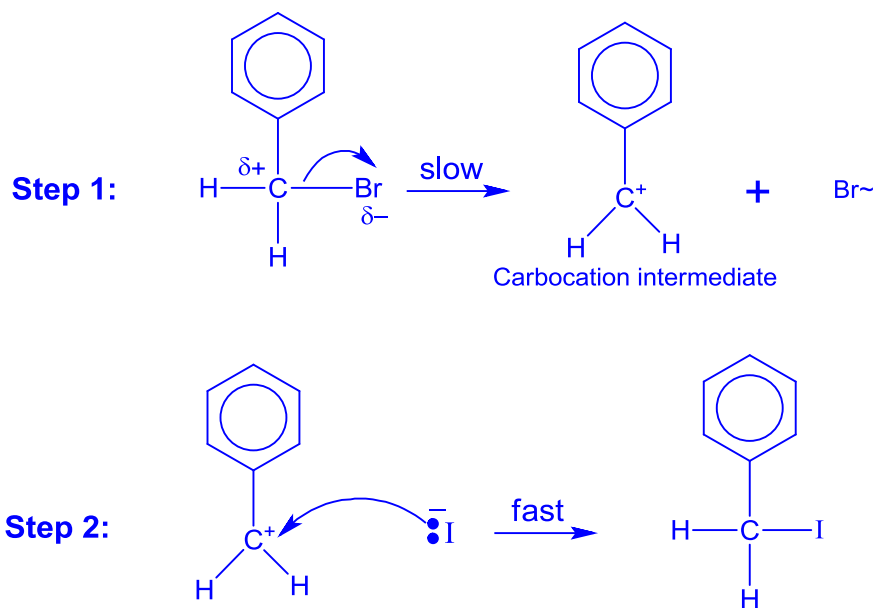

- (i) Add $\text{AgNO}_3(\text{aq})$. Observation: No yellow precipitate observed.
- (ii) The $\text{C}_6\text{H}_5\text{CH}_2^+$ carbocation is resonance stabilised
- (ci) KBr is precipitated out as a solid. Position of equilibrium shifts to the right.

(ii)

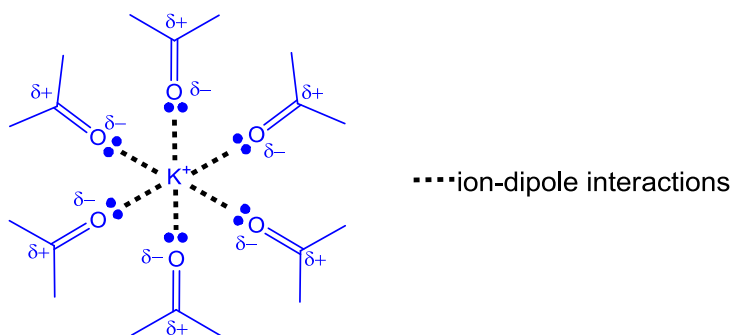

(iii) Enthalpy change of solution for KI in propanone is more exothermic.

(di) As a base.

(ii) $BE(C-I) = 240 \text{ kJ mol}^{-1}$; $BE(C-Br) = 280 \text{ kJ mol}^{-1}$

The C-Br bond is stronger than C-I bond hence rate is slower.

(iii) Step III: alkaline $\text{KMnO}_4(\text{aq})$, heat

Step IV: alkaline aq I_2 , heat

Step V: hydrogen iodide

(iv)

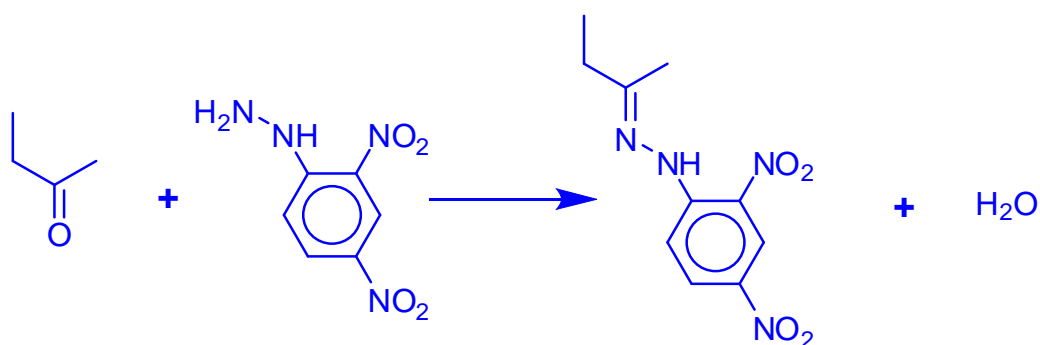

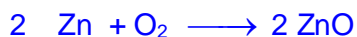

(ii) $+1.59 = 0.40 - E^\ominus (\text{ZnO} / \text{Zn})$

$E^\ominus (\text{ZnO} / \text{Zn}) = - 1.19 \text{ V}$

(iii) Prevent entry of O_2 so to minimise the battery's discharging process to prolong the shelf-life of the battery.

(iv) Partial pressure of O_2 hence the equilibrium position shifts left. $E^\ominus_{(\text{O}_2/\text{OH}^-)}$ will be less positive hence $E_{\text{cell}} < 1.59 \text{ V}$.

(v) No. of moles of $\text{O}_2 = \frac{I \times t}{n \times F} = \frac{I \times 60 \times 60}{4 \times 96500}$

Current output of battery = 0.188 A



(ii) Zn^{2+} 0.074 nm; Ba^{2+} : 0.135 nm. Charge density: $\text{Zn}^{2+} > \text{Ba}^{2+}$. Zn^{2+} distorts the anion charge cloud to a greater extent, weakening and breaking the C–O bond in CO_3^{2-} . Hence, decomposition temperature of ZnCO_3 is lower than BaCO_3 .

(iii)

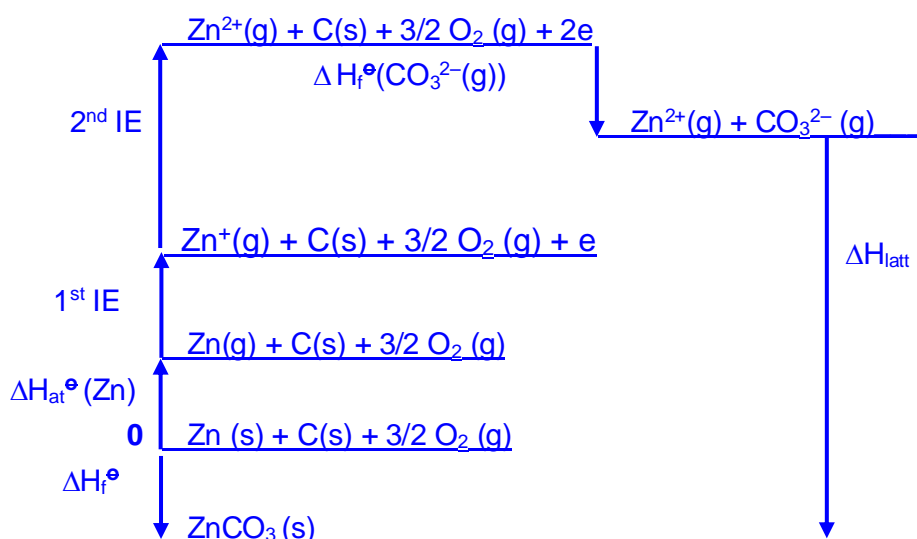

By Hess' Law, $\Delta H_{\text{latt}} (\text{ZnCO}_3) = - 3266 \text{ kJ mol}^{-1}$

- (c) Zn is a heterogeneous catalyst because of the availability of 3d & 4s electrons for temporary bond formation with reactants. Reactant molecules are adsorbed onto the Zn catalyst surface. This adsorption increases the surface concentration of the reactants and weakens the covalent bonds lowering the activation energy such that molecules are brought close for reaction to take place easily. Products formed diffuse away from the surface of the catalyst.

(d)

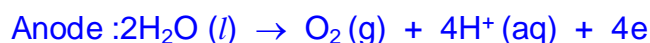
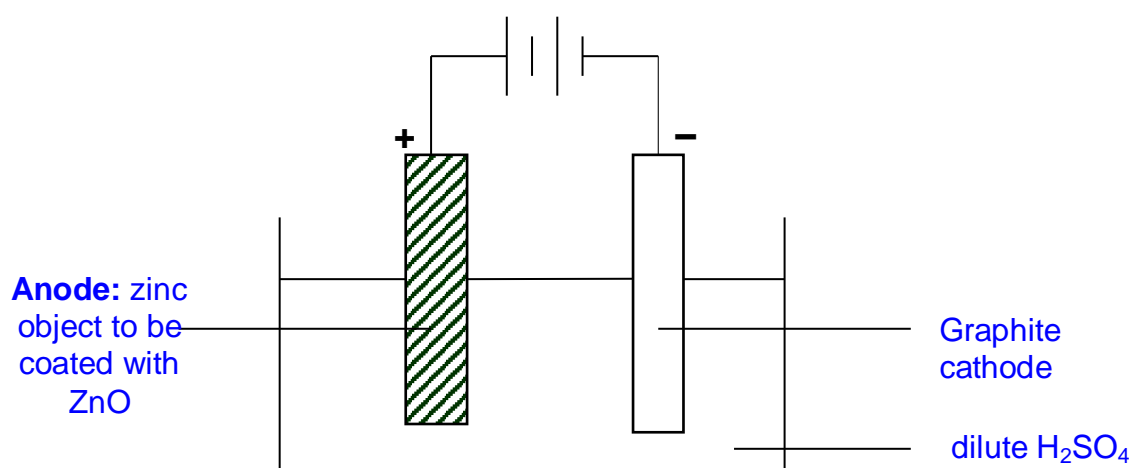

3(ai) No of moles of NO_2 gas produced = $\frac{PV}{RT} = \frac{1.01 \times 10^5 \times 103.7 \times 10^{-6}}{8.31 \times 353}$

$$M_r \text{ of atorvastatin} = \frac{1}{1.785 \times 10^{-3}} = 560$$

- (ii) NO_2 is a real gas with significant intermolecular forces of attraction.

- (bi) No of tablets required in year = 2×365 .

$$\text{No of bottles needed} = \frac{730}{90} = 8.11 \approx 9$$

- (ii) The weak van der Waal's forces between the *atorvastatin* molecules is compatible with that between CCl_4 molecules. The *atorvastatin* calcium cannot form ion-dipole interaction with the CCl_4 molecules, hence it will not dissolve.

(i)

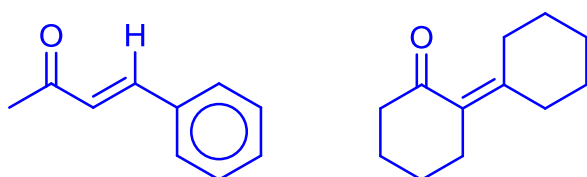
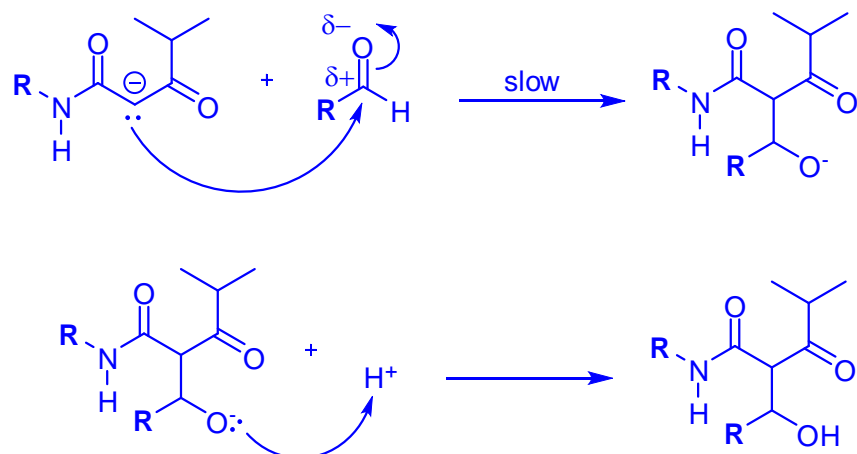

(ii)

(di) $NaBH_4$ in ethanol

(ii) Nucleophilic substitution

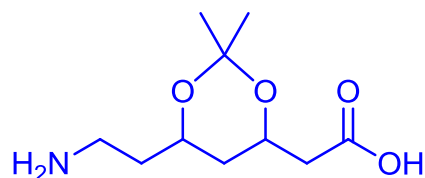

(iii)

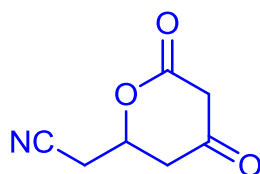

(iv)

(e) The carboxylic acid group has higher K_a . The carboxylate anion is resonance stabilised. The alcohol has lower K_a . The electron donating alkyl group increases the intensity of the negative charge on the oxygen atom of the alkoxide anion hence destabilising it.

(ii)

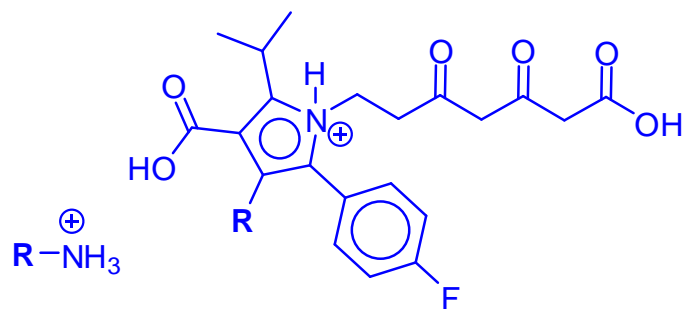

4(ai) $\Delta H_{\text{rxn}} = 2(1079) + 4(460) + 1(350) + 2(610) + 6(410) - [5(350) + 2(740) + 2(360) + 2(460) + 8(410)] = -122 \text{ kJ mol}^{-1}$

(ii) The difference is due to ΔH_{fusion} plus vaporisation of adipic acid. *Accept other answers.*

(iii) For adipoyl dichloride, the carbonyl C atom is bonded to electronegative atoms hence the electron deficient carbonyl C atom is very susceptible to hydrolysis. For compound A, the lone electron pair of the chlorine atom is delocalised with the adjacent C=C double bond hence rendering partial double bond character.

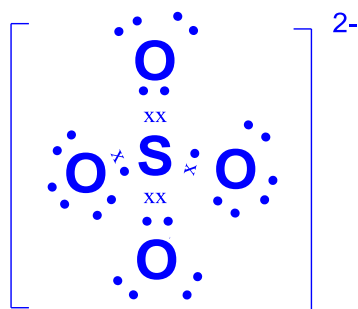

(bi)

(ii)

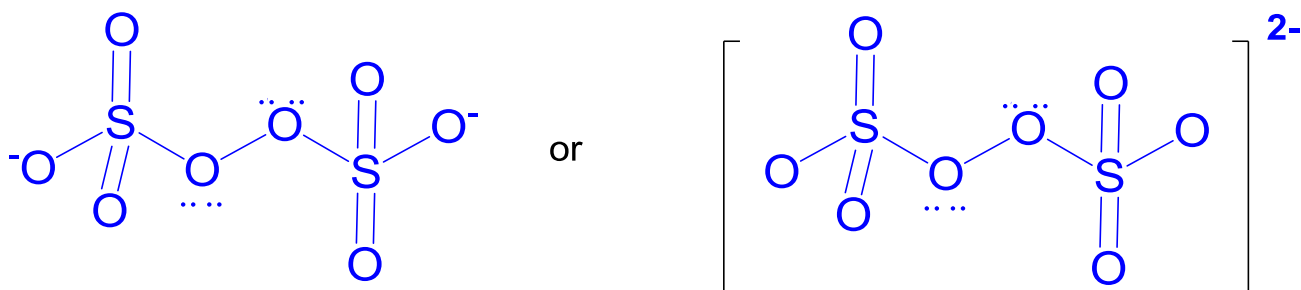

The shape with respect to S is tetrahedral.
The shape with respect to O is bent

(iii) Let $y \text{ dm}^3$ = vol of base added.

No. of mole of $\text{HA}^- = 0.2y$

Final no. of mole of $\text{H}_2\text{A} = 5 \times 10^{-3} - 0.2y$

$$4.6 = 4.4 + \lg \frac{0.2y/(0.5+y)}{(5 \times 10^{-3} - 0.2y)/(0.5+y)}$$

$$y = 0.0153 \text{ dm}^3$$

(ci) **B** undergoes acidic hydrolysis \rightarrow **B** is an ester.

C does not undergo condensation with 2,4-dinitrophenylhydrazine.

\rightarrow **C** does not contain aldehyde or ketone

C undergoes elimination with hot Al_2O_3 . \rightarrow **E** to **G** contains alkene

E and **F** are cis-trans isomers and **G** contains chiral carbon and is a structural isomer of **E** & **F**.

D undergoes oxidation with Fehling's \rightarrow **D** contains aliphatic aldehyde.

D is ethanedioic acid and it undergoes further oxidation to form carbon dioxide.

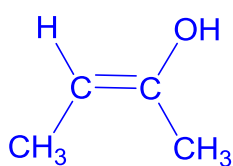
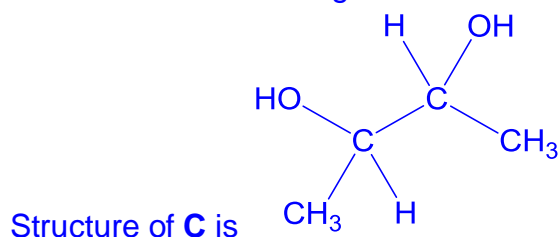

E

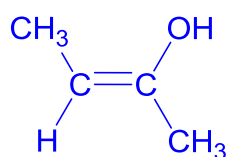

F

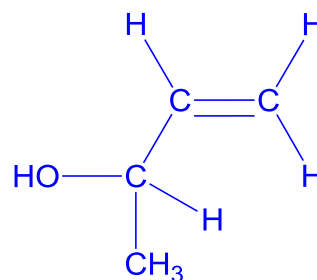

G

E and F (can interchange)

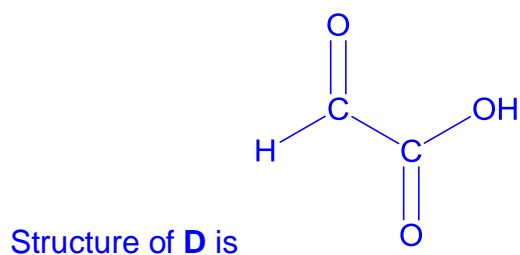

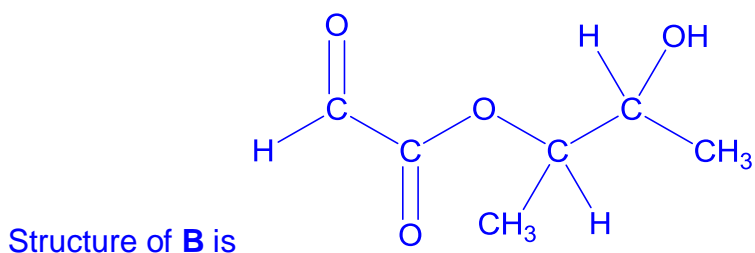

(i)

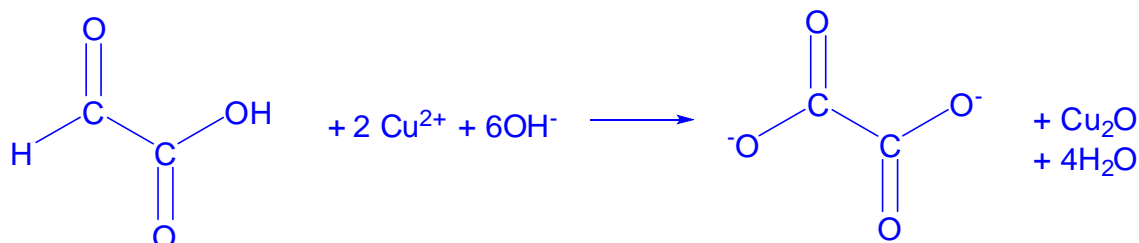

5(a) Quaternary structure is the combination of two or more polypeptide chains interacting to form a more complex structure. The sub-units in the structure interact via van der Waals' forces, ionic bonds and hydrogen bonds.

(bi) $[O_2] = \frac{(0.13 \times 1.01 \times 10^5)}{(8.31)(298)} = 5.30 \times 10^{-3} \text{ mol dm}^{-3}$. Accept answer in mol m^{-3}

$$K_c = 0.33 \times \frac{1}{5.30 \times 10^{-3}} = 62.3$$

(ii) $\Delta G = - (8.31) (298) \ln (62.3) = - 10.2 \text{ kJ mol}^{-1}$

(iii) ΔS is negative since there is a decrease in disorder as there is a decrease in number of moles of gas. ΔH is negative. When temperature is high, $|\Delta H| < |T\Delta S|$, hence ΔG is positive hence oxygenation of squid is not supported leading to death.

(iv) Cu(II) has partially-filled d orbitals. The d orbitals are split into two groups by ligands. The d electron is promoted to the *higher* d orbital. During the transition, the d electron absorbs red/ orange/yellow wavelength light from the visible region of the electromagnetic spectrum and the remaining wavelengths (blue) not absorbed will appear as the colour observed.

(c) *gly – ile – val – glu – gln – cys – cys – ala – ser – val – cys – ser – leu*

(d) van der Waals' attraction between *val* and *leu*; hydrogen bond between *gln* and *ser*; disulfide bond between side chains of *cys*.

(e)

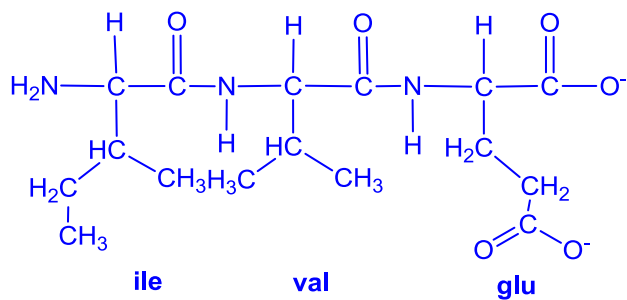

(fi) The plot is a straight line graph. $[\text{NaOH}]$ is kept constant hence the rate is independent of $[\text{NaOH}]$

(ii) $-k' = -8.21 \times 10^{-10}$ Allow range of $8.0 - 8.4 \times 10^{-10}$

(iii) $8.21 \times 10^{-10} = k[1.5]$
 $k = 5.47 \times 10^{-10}$

(g)

pH 2.4

pH 7.0

