



**JURONG JUNIOR COLLEGE**  
**2017 JC 2 PRELIMINARY EXAMINATION**  
**Higher 2**

CANDIDATE  
NAME

CLASS

17S

EXAM INDEX

---

**CHEMISTRY**

**9729/01**

Paper 1 Multiple Choice

**14 September 2017**

**1 hour**

Candidates answer on separate paper.

Additional Materials:      Multiple Choice Answer Sheet  
   Data Booklet

---

**READ THESE INSTRUCTIONS FIRST**

Write in soft pencil.

Do not use staples, paper clips, glue or correction fluid.

Write your name, class and exam index number on the Answer Sheet in the spaces provided unless this has been done for you.

There are **thirty** questions on this paper. Answer **all** questions. For each question there are four possible answers **A, B, C** or **D**.

Choose the **one** you consider correct and record your choice in **soft pencil** on the separate Answer Sheet.

**Read the instructions on the Answer Sheet very carefully.**

Each correct answer will score one mark. A mark will not be deducted for a wrong answer.

Any rough working should be done in this booklet.

The use of an approved scientific calculator is expected, where appropriate.

---

This document consists of **13** printed pages and **1** blank page.

## 2

- 1 When a beam of protons ( ${}^1\text{H}^+$ ), travelling at the same speed, passes through an electric field of constant strength, the angle of deflection is  $+12^\circ$ .

Assuming an identical set of experimental conditions, which particle would be deflected through an angle of  $+8^\circ$ ?

- A  ${}^6\text{Li}^{4-}$                       B  ${}^6\text{Li}^{2+}$                       C  ${}^3\text{He}^{2+}$                       D  ${}^{12}\text{C}^{3-}$

- 2 1,3,5-triazine is an aromatic compound and its structure resembles that of benzene. The structure of 1,3,5-triazine is shown below.

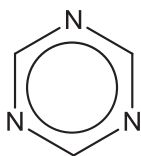

1,3,5-triazine

Which statement about 1,3,5-triazine is correct?

- A The empirical formula of 1,3,5-triazine is CN.  
 B A molecule of 1,3,5-triazine has six  $\sigma$  bonds.  
 C The  $\pi$  bond between carbon and nitrogen atoms is formed by  $sp^2-sp^2$  overlap.  
 D All the carbon–nitrogen bonds have equal bond lengths.
- 3 In which pair does the first substance have a higher boiling point than the second?

	First substance	Second substance
A	HF	HCl
B	$\text{CH}_3\text{COCH}_3$	$(\text{CH}_3)_2\text{NH}$
C	$(\text{CH}_3)_3\text{CH}$	$\text{CH}_3\text{CH}_2\text{CH}_2\text{CH}_3$
D		

- 4 The following diagram shows the contents of three vessels which are joined together by a connecting tube which is evacuated of air.

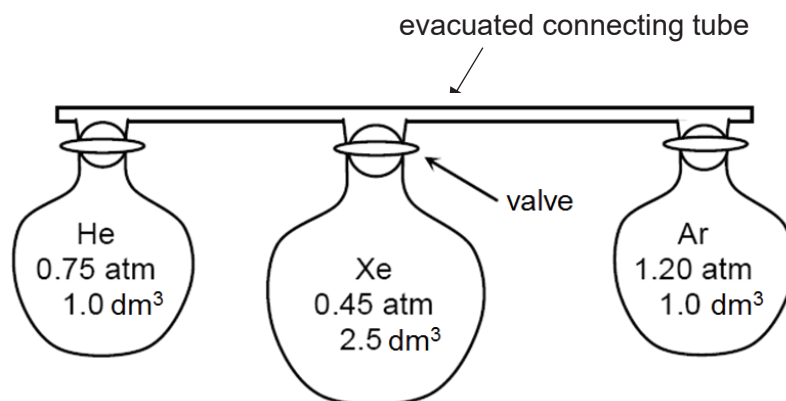

After the valves on the vessels are opened, the final pressure is measured and is found to be 0.675 atm.

Assuming that the temperature of the whole setup is maintained at 30 °C, what is the volume of the connecting tube?

- A** 0.023 dm<sup>3</sup>      **B** 0.040 dm<sup>3</sup>      **C** 0.056 dm<sup>3</sup>      **D** 0.094 dm<sup>3</sup>

- 5 *Use of the Data Booklet is relevant to this question.*

Furfuryl thiol ( $M_r = 114$ ) is the key component of the aroma of roasted coffee.

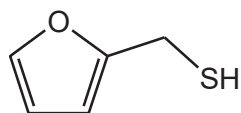

furfuryl thiol

Which statements about furfuryl thiol are correct?

- On complete combustion, 0.10 g of furfuryl thiol produces 0.23 g of CO<sub>2</sub>.
- On complete combustion, 0.10 g of furfuryl thiol produces 21 cm<sup>3</sup> of SO<sub>2</sub> measured under r.t.p.
- On complete combustion, 0.10 g of furfuryl thiol produces 0.16 g of H<sub>2</sub>O.
- 0.10 g of furfuryl thiol reacts with an excess of bromine to produce 0.38 g of product. Assume that the -SH group in furfuryl thiol does not react with bromine.

- A** 1, 2 and 4 only  
**B** 1, 3 and 4 only  
**C** 2 and 3 only  
**D** 2 and 4 only

- 6 A solution mixture contains both sodium carbonate ( $M_r = 106$ ) and sodium hydrogen carbonate ( $M_r = 84.0$ ).

25.0 cm<sup>3</sup> of the solution mixture was titrated against 0.300 mol dm<sup>-3</sup> hydrochloric acid. 15.0 cm<sup>3</sup> of HCl is required to decolourise the phenolphthalein indicator. A few drops of methyl orange indicator was then added and a further 20 cm<sup>3</sup> of HCl is required for methyl orange indicator to change colour.

What is the percentage, by mass, of sodium carbonate present in the solution mixture?

- A 20.9 %                      B 25.0 %                      C 75.0 %                      D 79.1 %

- 7 Sodium carbonate reacts with ethanoic acid according to the equation below.

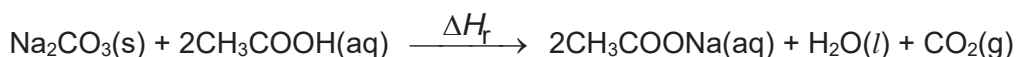

In an experiment to determine the enthalpy change of reaction,  $\Delta H_r$ , 7.5 g of solid sodium carbonate ( $M_r = 106$ ) was added to 50 cm<sup>3</sup> of excess aqueous ethanoic acid at the second minute. The temperature of the resultant solution was monitored at various time intervals and the following graph was obtained.

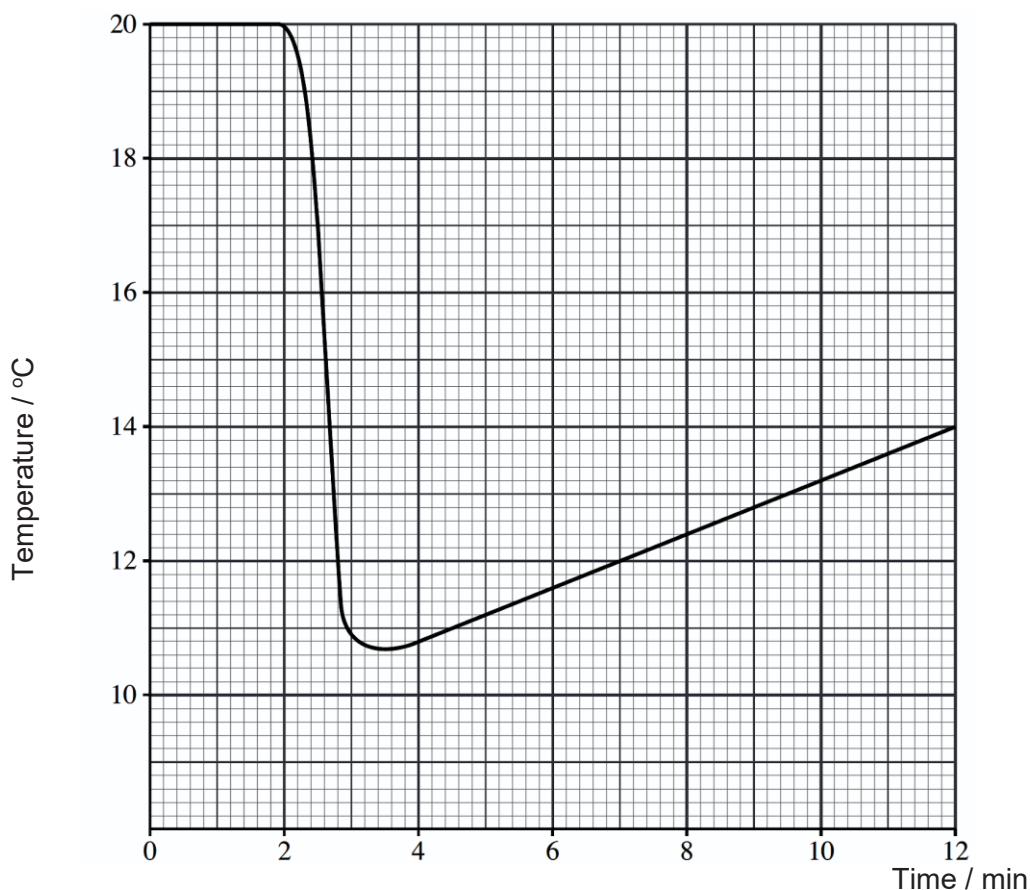

Given that the specific heat capacity of the solution is 4.18 J cm<sup>-3</sup> K<sup>-1</sup>, what is the most accurate enthalpy change of reaction,  $\Delta H_r$ , which can be obtained from this graph?

- A +17.7 kJ mol<sup>-1</sup>                      B +27.5 kJ mol<sup>-1</sup>  
 C +29.5 kJ mol<sup>-1</sup>                      D +31.0 kJ mol<sup>-1</sup>

- 8 The kinetic of the following reaction is studied, using a colorimeter, by finding the time taken for the coloured reactant, **E**, to decolourise. The reaction is catalysed by **Y**.



The following results are obtained:

Experiment	Volume of solution added / cm <sup>3</sup>				Time taken / s
	E	F	Y	H <sub>2</sub> O	
1	10	20	10	10	20
2	10	10	10	20	40
3	10	20	5	15	40
4	5	20	10	15	10

What is the rate equation for the reaction?

- A** rate =  $k[\text{E}][\text{F}]$                       **B** rate =  $k[\text{E}][\text{Y}]$   
**C** rate =  $k[\text{F}][\text{Y}]$                         **D** rate =  $k[\text{E}][\text{F}][\text{Y}]$

- 9 The diagram represents the Boltzmann distribution of molecular energies at a given temperature.

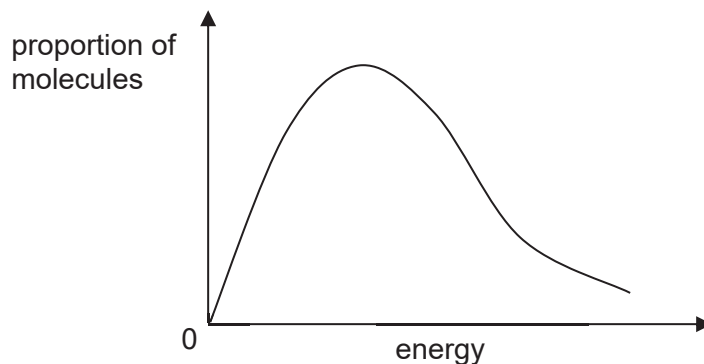

As the temperature increases, which statements are correct?

- The maximum of the curve is displaced to the right.
- The proportion of molecules with energies above any given value increases.
- The proportion of molecules with any given energy increases.

- A** 1 only  
**B** 1 and 2 only  
**C** 2 and 3 only  
**D** 1, 2 and 3

- 10 The interhalogen compound  $\text{BrF}_3$  is a volatile liquid which autoionises.



The electrical conductivity of  $\text{BrF}_3$  decreases with increasing temperature.

Which statement about the autoionisation process is correct?

- A The autoionisation process is endothermic and the shape of the cation is linear.  
 B The autoionisation process is endothermic and the shape of the cation is non-linear.  
 C The autoionisation process is exothermic and the shape of the cation is linear.  
 D The autoionisation process is exothermic and the shape of the cation is non-linear.
- 11 The graph below shows how the fraction of **X**, which represents one of the following compounds in the equilibrium mixture shown below, varies with temperature at pressures of **Y** Pa and **Z** Pa.

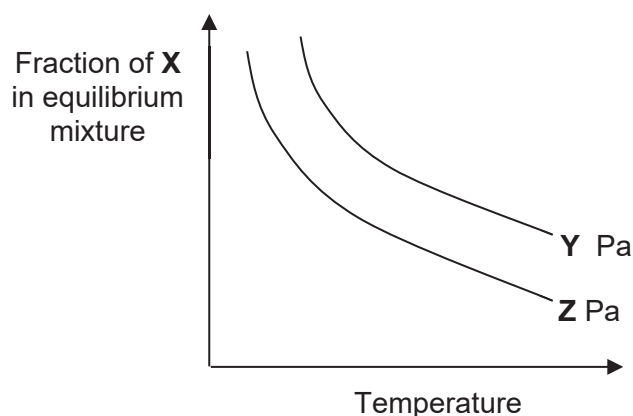
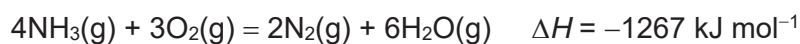

Identify **X** and the correct relative magnitudes of **Y** and **Z**.

	<b>X</b>	<b>Pressure</b>
<b>A</b>	$\text{N}_2$	<b>Z &gt; Y</b>
<b>B</b>	$\text{O}_2$	<b>Y &gt; Z</b>
<b>C</b>	$\text{H}_2\text{O}$	<b>Y &gt; Z</b>
<b>D</b>	$\text{NH}_3$	<b>Z &gt; Y</b>

- 12 What is the pH of an aqueous solution containing  $0.1 \text{ mol dm}^{-3}$  sodium benzoate and  $0.01 \text{ mol dm}^{-3}$  benzoic acid? [ $K_a$  (benzoic acid) =  $6 \times 10^{-5} \text{ mol dm}^{-3}$ ]
- A 3.22                      B 4.22                      C 4.78                      D 5.22

- 13 When 25.0 cm<sup>3</sup> of a 0.100 mol dm<sup>-3</sup> strong monobasic acid was titrated against 0.200 mol dm<sup>-3</sup> of a weak base **Q**, 12.50 cm<sup>3</sup> of the base was required to completely neutralise the acid.

Which statements are correct for this experiment?

- 1 **Q** is a diprotic base.
- 2 The pH of the solution at the equivalence point is 7.
- 3 A solution of maximum buffering capacity was formed when 6.25 cm<sup>3</sup> of the base was added.

- A** 3 only  
**B** 1 and 2 only  
**C** 2 and 3 only  
**D** None of the above

- 14 The numerical values of the solubility products of three metal sulfides are tabulated below.

Compound	Numerical value of solubility product
CuS	$6.3 \times 10^{-36}$
ZnS	$1.6 \times 10^{-21}$
Bi <sub>2</sub> S <sub>3</sub>	$1.1 \times 10^{-73}$

Which of the following shows the three metal sulfides arranged in order of increasing molar solubility in water?

	lowest	—————▶	highest
<b>A</b>	Bi <sub>2</sub> S <sub>3</sub>	CuS	ZnS
<b>B</b>	ZnS	CuS	Bi <sub>2</sub> S <sub>3</sub>
<b>C</b>	ZnS	Bi <sub>2</sub> S <sub>3</sub>	CuS
<b>D</b>	CuS	Bi <sub>2</sub> S <sub>3</sub>	ZnS

- 15 Four compounds of some Period 3 elements are listed below.



Which pair of compounds, when mixed in water, could give a resultant solution of pH 7?

- A** NaCl and Na<sub>2</sub>O                      **B** NaCl and SO<sub>2</sub>  
**C** Na<sub>2</sub>O and SiCl<sub>4</sub>                      **D** SiCl<sub>4</sub> and SO<sub>2</sub>

- 16 Corticosterone is a hormone involved in the metabolism of carbohydrates and proteins.

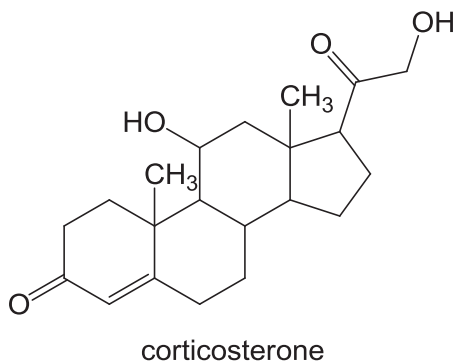

How many possible stereoisomers does Corticosterone has?

- A  $2^6$                       B  $2^7$                       C  $2^8$                       D  $2^9$
- 17 Which of the following transformation will occur under the given conditions?

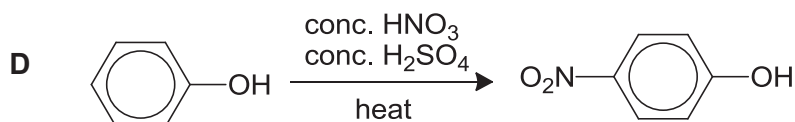
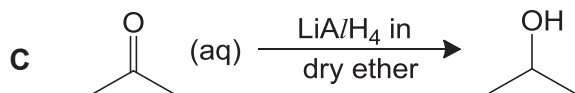
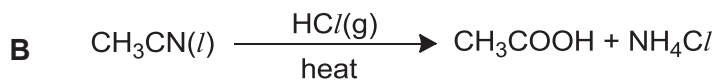
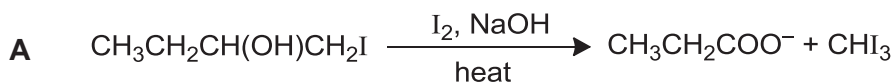

- 18 Gem-diols, in which both hydroxyl groups are bonded to the same carbon, can spontaneously eliminate a molecule of water to produce a carbonyl compound.

Which compound, after complete hydrolysis, gives a precipitate when warmed with  $[\text{Ag}(\text{NH}_3)_2]^+$  complex?

- A 1,1-dibromobutane  
 B 1,2-dibromobutane  
 C 2,2-dibromobutane  
 D 2,3-dibromobutane



- 19  $\beta$ -carotene is responsible for the orange colour of carrots and its structure is shown below.

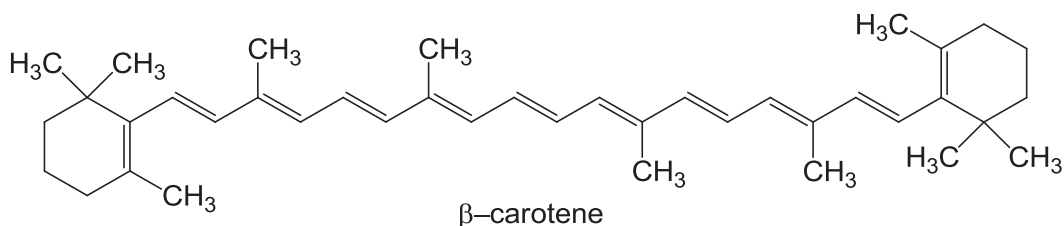

When a molecule of  $\beta$ -carotene is oxidised by hot, concentrated acidified  $\text{KMnO}_4$ , many product molecules are formed.

How many of these product molecules contain the ketone functional group?

- A 4                      B 6                      C 9                      D 11
- 20 Lactic acid,  $\text{CH}_3\text{CH}(\text{OH})\text{CO}_2\text{H}$ , causes pain when its concentration builds up in muscles.

Which reagents react with **both** of the  $-\text{OH}$  groups in lactic acid?

- 1 hydrogen bromide
- 2 phosphorus pentachloride
- 3 sodium
- 4 sodium hydroxide

- A 1 and 2  
 B 1 and 4  
 C 2 and 3  
 D 3 and 4

- 21 Which of the following represents the correct sequence of increasing  $\text{p}K_a$  value of the four compounds?

	smallest $\text{p}K_a$	—————▶		largest $\text{p}K_a$
A	$\text{CCl}_3\text{CO}_2\text{H}$	$\text{CH}_3\text{CO}_2\text{H}$	$\text{C}_6\text{H}_5\text{OH}$	$\text{C}_2\text{H}_5\text{OH}$
B	$\text{CCl}_3\text{CO}_2\text{H}$	$\text{CH}_3\text{CO}_2\text{H}$	$\text{C}_2\text{H}_5\text{OH}$	$\text{C}_6\text{H}_5\text{OH}$
C	$\text{C}_6\text{H}_5\text{OH}$	$\text{C}_2\text{H}_5\text{OH}$	$\text{CCl}_3\text{CO}_2\text{H}$	$\text{CH}_3\text{CO}_2\text{H}$
D	$\text{C}_2\text{H}_5\text{OH}$	$\text{C}_6\text{H}_5\text{OH}$	$\text{CH}_3\text{CO}_2\text{H}$	$\text{CCl}_3\text{CO}_2\text{H}$

22 Consider the following compound **G**.

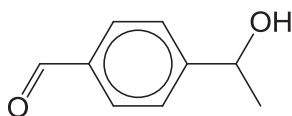

**G** is heated with acidified  $K_2Cr_2O_7$  to form compound **H**.

Both **G** and **H** are then separately warmed with Fehling's solution and the observations are noted.

What are the observations?

- A** Both **G** and **H** give a red precipitate.
- B** Only **G** gives a red precipitate.
- C** Only **H** gives a red precipitate.
- D** Neither **G** nor **H** gives a red precipitate.

23 Chloroethane can be used to make sodium propanoate.

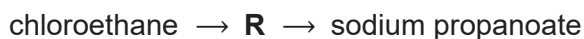

The intermediate, **R**, is treated with boiling aqueous sodium hydroxide to give sodium propanoate.

Which reagent would produce the intermediate, **R**, from chloroethane?

- A** alkaline  $KMnO_4$
- B** hydrogen cyanide
- C** sodium hydroxide in ethanol
- D** potassium cyanide in ethanol

24 Which statements about the formation of a carboxylic acid are correct?

- 1 A carboxylic acid can be produced by oxidation of a primary alcohol.
- 2 A carboxylic acid can be produced by reduction of a nitrile.
- 3 A carboxylic acid can be produced by reduction of an aldehyde.
- 4 A carboxylic acid can be produced by hydrolysis of an acyl chloride.

- A** 1 and 3
- B** 1 and 4
- C** 2 and 3
- D** 2 and 4

- 25 Part of the structure of a fungicide, strobilurin, is shown. R and R' are inert groups.

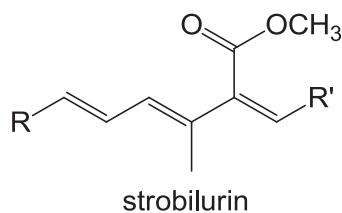

In this reaction, strobilurin is warmed with aqueous sulfuric acid to give compound X. Compound X is then treated with hydrogen in the presence of a nickel catalyst to give compound Y.

What could be the structure of compound Y?

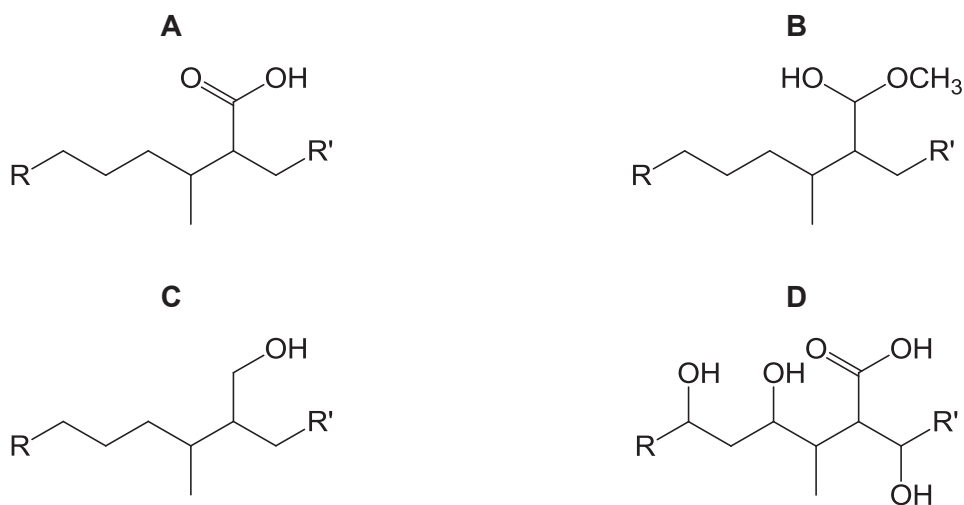

- 26 Why are amides, RCONH<sub>2</sub>, less basic than amines, RNH<sub>2</sub>?

- A Amides form a zwitterion in which the nitrogen atom carries a positive charge.
- B Amides have a resonance structure involving the movement of a pair of electrons from the nitrogen atom to the oxygen atom.
- C Electrons on the nitrogen atom move on to the C–N bond giving it some double bond character so that it is more difficult to break.
- D The amide carbonyl group withdraws electrons from the NH<sub>2</sub> group to make the hydrogen atoms acidic.

27 Which conditions are necessary when an electrode potential is measured using a standard hydrogen electrode as the reference electrode?

- 1 The use of hydrogen gas at 1 bar and 298 K.
- 2 Measurement of e.m.f. when the current delivered by the cell is effectively zero.
- 3 A pH of 1.0 for the solution at the hydrogen electrode.

- A 1 and 2 only  
 B 1 and 3 only  
 C 2 and 3 only  
 D 1, 2 and 3

28 The use of Data Booklet is relevant to this question.

Peroxodisulfate ions convert iodide ions into iodine slowly.

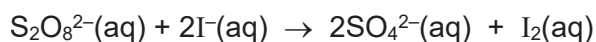

The rate of the reaction can be increased by adding catalysts such as aqueous iron(III) ions.

A possible pathway of a catalyst reaction involves the following steps:

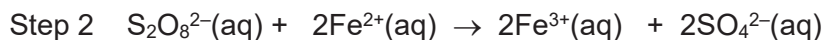
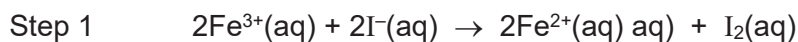

Which statement about the reaction is **incorrect**?

- A  $\text{S}_2\text{O}_8^{2-}$  is a stronger oxidising agent than  $\text{Fe}^{3+}$ .  
 B The reaction between  $\text{S}_2\text{O}_8^{2-}$  and  $\text{I}^-$  is slow because the  $E^\ominus_{\text{cell}}$  value is small.  
 C The  $E^\ominus_{\text{cell}}$  for step 2 is more positive than step 1.  
 D Aqueous cobalt(II) ions can be used as a catalyst for this reaction.

29 The following data refers to iron as a typical transition element and to calcium as an s-block element.

For which property are the data under the correct element?

	Property	Fe	Ca
A	density	7.87	1.54
B	electrical conductivity	9.6	85
C	melting point	810	1538
D	metallic radius	0.231	0.140

- 30** When aqueous ammonia is added to a solution containing hexaaquacopper(II) ions,  $[\text{Cu}(\text{H}_2\text{O})_6]^{2+}$ , a pale blue precipitate is formed. When excess ammonia is added, blue precipitate dissolves to form a dark blue solution.

What are the roles of the ammonia molecules in the above reactions?

1 Bronsted–Lowry base

2 Ligand

3 Reducing agent

**A** 1 only

**B** 2 only

**C** 1 and 2 only

**D** 2 and 3 only





JURONG JUNIOR COLLEGE  
2017 JC 2 PRELIMINARY EXAMINATION  
Higher 2

CANDIDATE  
NAME

CLASS

17S

EXAM INDEX

## CHEMISTRY

9729/02

Paper 2 Structured Questions

29 August 2017

2 hours

Candidates answer on the Question Paper.

Additional Materials: Data Booklet

### READ THESE INSTRUCTIONS FIRST

Write your name, class and exam index number on all the work you hand in.

Write in dark blue or black pen on both sides of the paper.

You may use a HB pencil for any diagrams, graphs.

Do not use staples, paper clips, glue or correction fluid.

Answer **all** questions in the spaces provided on the Question Paper.

The use of an approved scientific calculator is expected, where appropriate.

A *Data Booklet* is provided.

At the end of the examination, fasten all your work securely together.

The number of marks is given in brackets [ ] at the end of each question or part question.

For Examiner's Use	
1	10
2	18
3	11
4	10
5	12
6	14
<b>Penalty</b> (delete accordingly)	
Lack <b>3sf</b> in final ans	-1 / NA
Missing/wrong <b>units</b> in final ans	-1 / NA
Bond linkages	-1 / NA
<b>Total</b>	

This document consists of 17 printed pages and 1 blank page.

Answer **all** the questions.

For  
Examiner's  
Use

- 1 (a) Draw a fully labelled diagram of the electrochemical cell you would set up in order to measure the standard electrode potential of the  $\text{Cu}^{2+}/\text{Cu}$  half-cell.

[3]

In the Earth's crust, copper often occurs as the sulfide associated with zinc sulfide. Pure copper is extracted from this mixture.

In the first stage of extraction, the copper extracted contains some zinc and silver impurities. Electrolysis was used to purify the extracted copper with impure copper as the anode, and pure copper at the cathode.

- (b) Using relevant data from the *Data Booklet*, explain what happens to the impurities at the anode.

.....

.....

.....

.....

.....

.....

.....

.....

.....

.....

.....

.....

.....

.....

.....

.....

.....

.....

.....

.....

.....

.....

[2]



1 (c) Using relevant data from the *Data Booklet*, explain what happens at the cathode.

.....  
.....  
.....  
.....  
.....  
.....  
.....  
.....  
.....  
.....  
.....  
.....  
.....  
.....  
.....

[2]

(d) A similar set up can be used for copper plating, using pure copper electrode as the anode.

Calculate the time taken to coat 0.50 g of copper on the object if a current of 0.20 A was passed through the electrolysis bath.

[3]

[Total: 10]

- 2 (a) 2-bromobutane,  $\text{CH}_3\text{CHBrCH}_2\text{CH}_3$ , is hydrolysed by aqueous sodium hydroxide.

The kinetics of the reaction can be monitored by withdrawing samples of the solution at appropriate times and titrating them with aqueous nitric acid after quenching.

Two sets of experiments were performed using different initial concentrations of the 2-bromobutane while the initial concentration of sodium hydroxide was kept at  $0.1 \text{ mol dm}^{-3}$ .

The results obtained are shown in the graphs below.

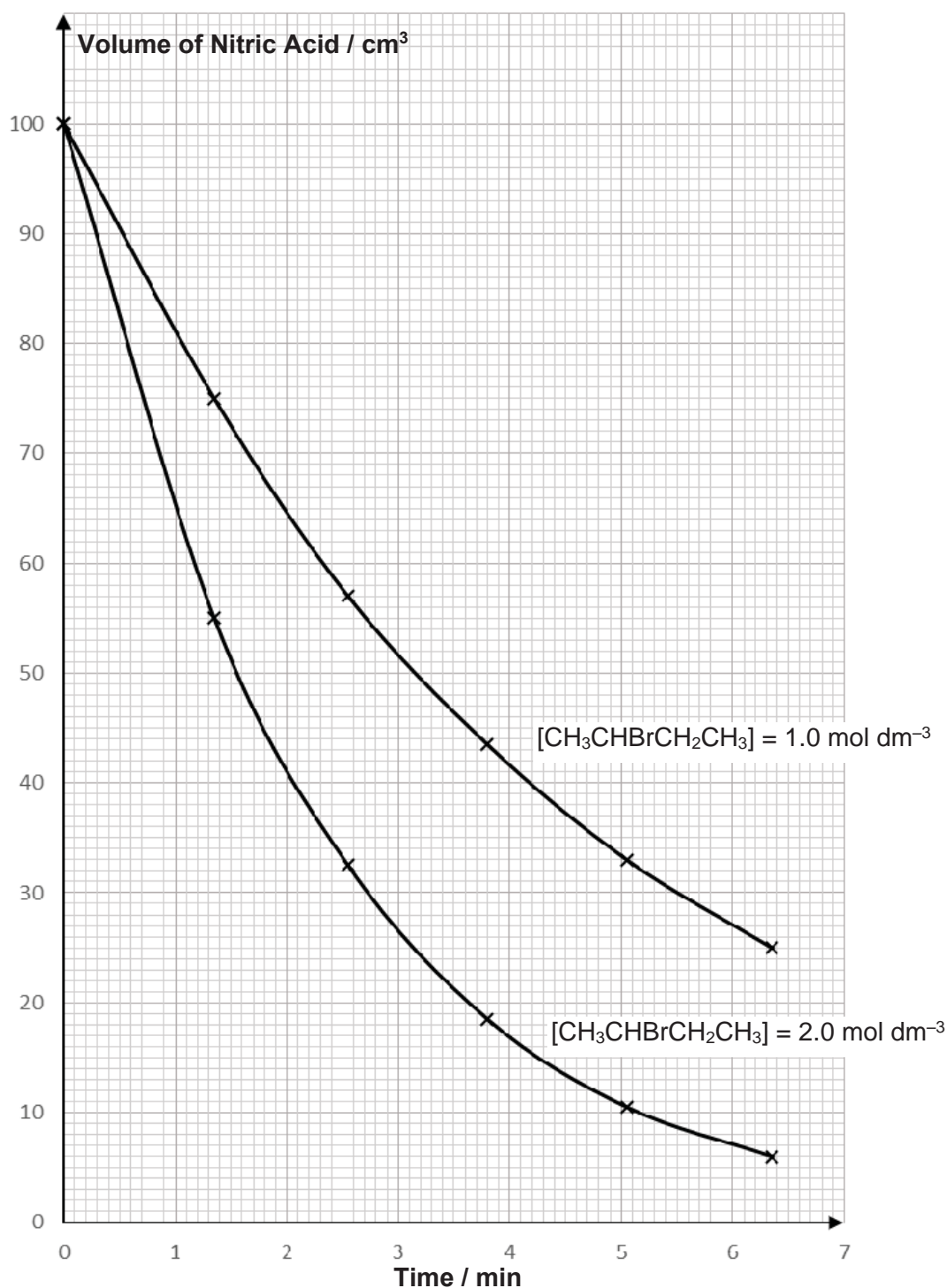

- 2 (a) (i) Using the graph where  $[\text{CH}_3\text{CHBrCH}_2\text{CH}_3] = 1.0 \text{ mol dm}^{-3}$ , find the order of reaction with respect to aqueous sodium hydroxide.

.....

.....

.....

.....

.....

.....

.....

[2]

- (ii) Using the graphs above, deduce the order of reaction with respect to 2-bromobutane.

.....

.....

.....

.....

.....

.....

.....

[3]

- (iii) Hence, write down the rate equation for this reaction.

.....

[1]

- (iv) State the half-life of sodium hydroxide when  $[\text{NaOH}] = 0.2 \text{ mol dm}^{-3}$  and  $[\text{CH}_3\text{CHBrCH}_2\text{CH}_3] = 1.0 \text{ mol dm}^{-3}$ .

.....

[1]

- (v) Calculate the time taken for  $[\text{NaOH}]$  to drop to 1 % of its original value when  $[\text{CH}_3\text{CHBrCH}_2\text{CH}_3] = 1.0 \text{ mol dm}^{-3}$ .

[1]

- 2 (b) (i) With reference to (a)(iii), name and describe the mechanism of this hydrolysis reaction.

Type of mechanism: .....

[3]

- (ii) Draw the energy profile diagram for the mechanism you have described in (b)(i).

On the diagram, label

- the reactants and products
- the enthalpy change of reaction,  $\Delta H$ ,
- the activation energy,  $E_a$

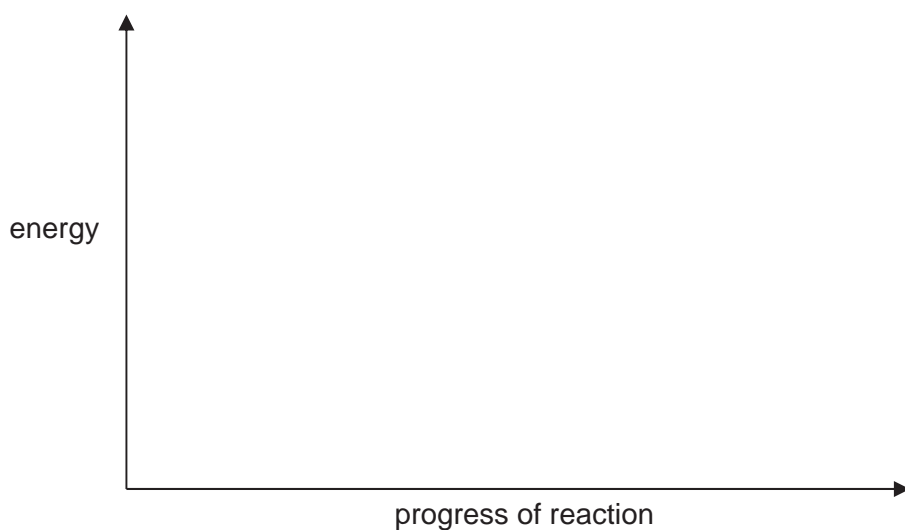

[3]

- (iii) How would the rate change if the experiment is repeated using 2-chlorobutane instead of 2-bromobutane? Explain.

.....

.....

.....

.....

.....

[2]

- 2 (b) (iv) State and explain if the resultant mixture will be optically active if the reaction started with an optically pure sample of 2-bromobutane.

.....

.....

.....

.....

[2]

[Total: 18]

- 3 Group 2 elements are ingredients in many important materials from cement to face cream.

A student carried out the following experiments as shown in the reaction scheme below using a sample of magnesium carbonate.

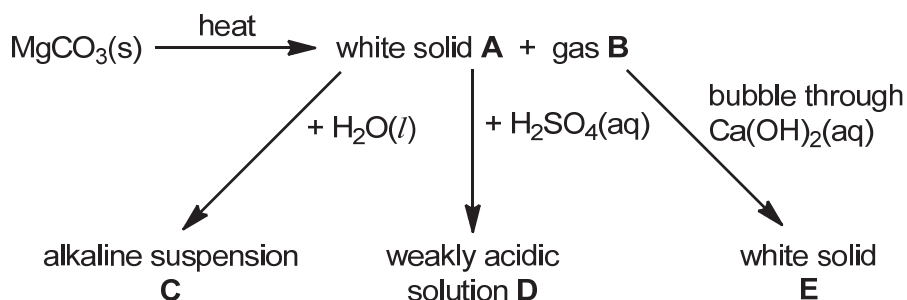

- (a) Identify compounds **A** to **E** in the reaction provided.

**A:** ..... **B:** ..... **C:** ..... **D:** ..... **E:** ..... [5]

- (b) Explain, with the aid of an equation, why solution **D** is weakly acidic.

.....

.....

.....

.....

.....

.....

[2]

- (c) The graph below shows the volume of gas **B** collected over time when 0.1 mol of magnesium carbonate is heated.

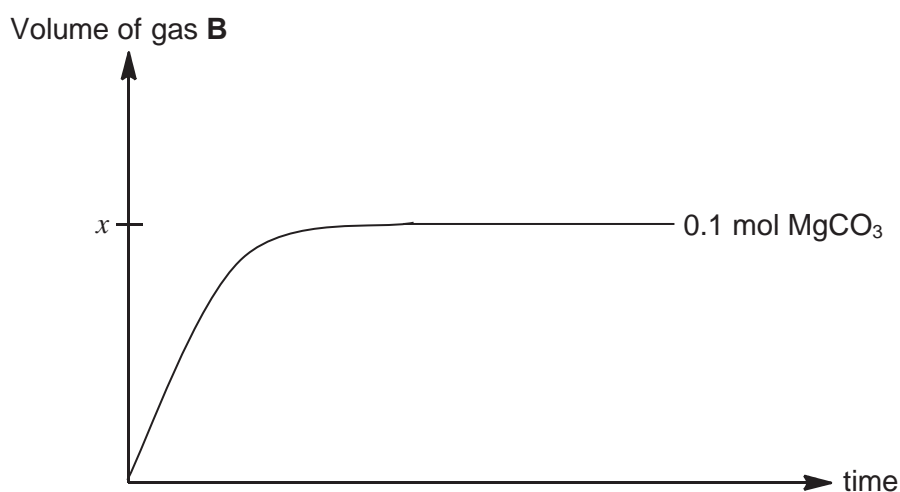

- (i) Draw, on the same axes above, the graph that would be obtained when 0.1 mol barium carbonate was used and heated until it decomposed completely.

[1]

3 (c) (ii) Explain the shape of the graph that you have drawn for (c)(i).

For  
Examiner's  
Use

.....

.....

.....

.....

.....

.....

.....

.....

.....

.....

.....

[3]

[Total: 11]

- 4 (a) Using relevant data from the *Data Booklet* and the following data, construct a labelled energy level diagram to calculate the enthalpy change of solution for gaseous hydrogen chloride.

$$\text{Electron affinity of chlorine} = -364 \text{ kJ mol}^{-1}$$

$$\text{Enthalpy change of hydration of hydrogen ion} = -1071 \text{ kJ mol}^{-1}$$

$$\text{Enthalpy change of hydration of chloride ion} = -381 \text{ kJ mol}^{-1}$$

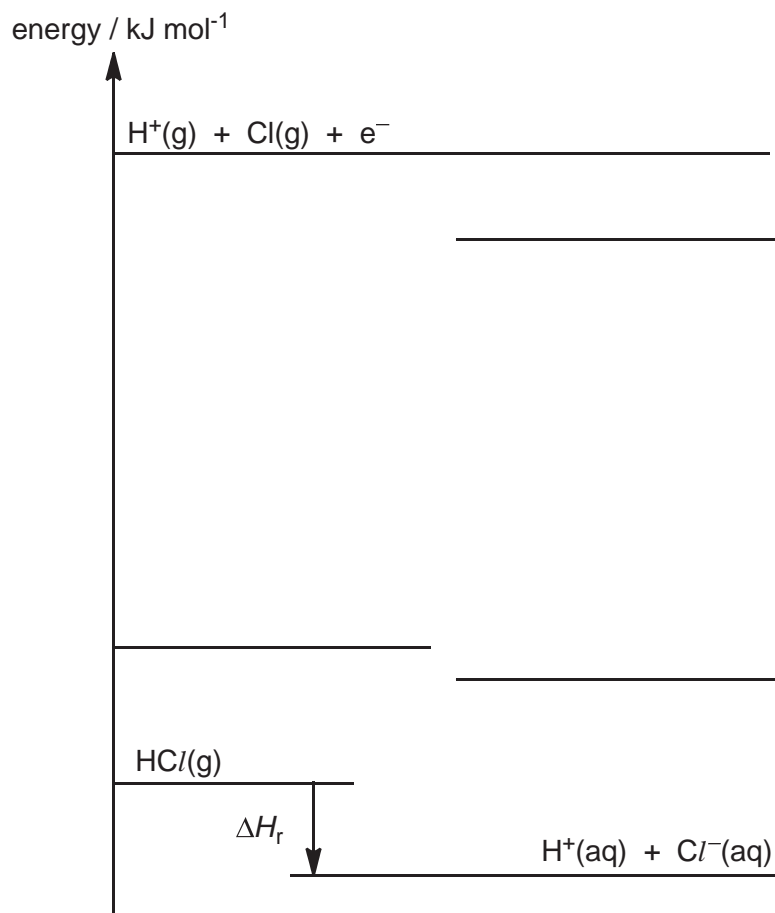

[3]

- (b) Hence, calculate  $\Delta G_{\text{soln}}$  for hydrogen chloride, given that  $T\Delta S_{\text{soln}}$  is  $-18 \text{ kJ mol}^{-1}$ .

[1]



- 4 (c) (i) Draw a labelled diagram to illustrate the interaction between chloride ion and water. State the type of interaction clearly in your diagram.

[2]

- (ii) Explain how the magnitude of enthalpy change of hydration of bromide ions differs from that of chloride ions.

.....  
.....  
.....  
.....  
.....

[2]

- (e) *Use of Data Booklet is relevant to this question.*

Both hydrogen chloride and hydrogen bromide dissolve readily in water.

Describe a chemical test, which does not involve silver nitrate, that could distinguish between aqueous solutions of these two gases.

.....  
.....  
.....  
.....  
.....

[2]

[Total: 10]

- 5 Amino acids are critical to life, and they serve as the building blocks of proteins. Out of the vast variety of amino acids, twenty are termed as essential because they cannot be created by the human body, and therefore must be supplied in the diet.

A peptide **A** was analysed and contained the following amino acids, [RCH(NH<sub>2</sub>)CO<sub>2</sub>H].

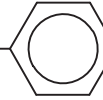
amino acid	abbreviation	formula of R group	number of residues
aspartic acid	asp	-CH <sub>2</sub> COOH	one
glycine	gly	-H	one
serine	ser	-CH <sub>2</sub> OH	two
tyrosine	tyr	-CH <sub>2</sub> -  -OH	one
valine	val	-CH(CH <sub>3</sub> ) <sub>2</sub>	one

- (a) Suggest suitable reagent and conditions for complete hydrolysis of proteins to amino acids non-enzymatically.

..... [1]

- (b) (i) Given that aspartic acid has pK<sub>a</sub> values of 2.0, 3.9 and 9.9, draw the structural formula of aspartic acid in its most stable state at pH 7.

[2]

- (ii) Electrophoresis was used to separate the amino acids in the mixture. Suggest, if any, whether aspartic acid will migrate towards the cathode or the anode.

..... [1]

- (c) (i) Draw a structure of the dipeptide with the sequence, ser-asp.

[2]

5 (c) (ii) Analysis of peptide **A** gave the following results:

- The N-terminus was shown to be ser.
- On reaction with a special reagent which digests at the carboxylic end of val, two peptides were obtained. One of these two was a dipeptide of sequence gly-ser.
- The enzyme chymotrypsin, which hydrolyses at the carboxylic group of tyr, gave two tripeptides.

Use these results to deduce the amino acid sequence of peptide **A**.

..... [2]

(d) Give the organic product(s) formed when tyrosine is subjected to the following reagents and conditions separately.

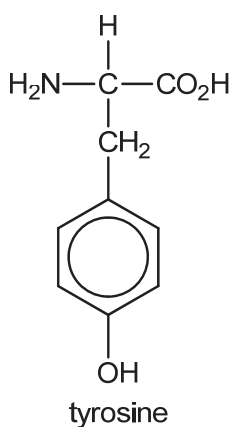

Reagent and Conditions	Organic Product(s)
Aqueous Br <sub>2</sub>	
Cold aqueous NaOH	
CH <sub>3</sub> COOH	

[4]

[Total: 12]

6 This question is about the reactions of Group 17 elements.

- (a) 10.0 cm<sup>3</sup> of an aqueous solution containing 0.10 mol dm<sup>-3</sup> Br<sub>2</sub> was added to 50.00 cm<sup>3</sup> of a 0.10 mol dm<sup>-3</sup> NaOH solution.

The resulting solution required 30.00 cm<sup>3</sup> of 0.10 mol dm<sup>-3</sup> HCl for complete neutralisation.

- (i) Calculate the mole ratio of Br<sub>2</sub> to NaOH.

[3]

- (ii) It was observed that during the reaction between Br<sub>2</sub> and NaOH, there is no gas evolved.

Given that the products formed are Br<sup>-</sup> and BrO<sub>x</sub><sup>-</sup>, write a balanced ionic equation for the reaction and hence deduce the value of  $x$ .

Balanced ionic equation: .....

Value of  $x$ : .....

[1]

- 6 (b) Mass spectrometry is an analytical technique which measures the masses of chemical species present within a sample. A mass spectrum can be used to determine the isotopic composition of a sample, masses of chemical species and to elucidate the chemical structure of a chemical compound.

The mass-to-charge ratio, also known as  $m/e$  value, is the  $M_r$  of chemical species present in the sample. The peak height ratio gives an indication of the isotopic ratio of elements in the sample.

In two separate experiments, propene was reacted with bromine in inert organic solvent and with aqueous bromine. The organic products were then extracted and analysed using mass spectrometry. The graphs below show the mass spectrum for each experiment.

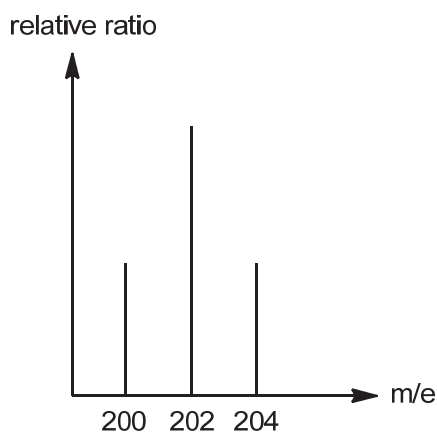

Fig 2.1: reaction with  $\text{Br}_2$  in inert solvent

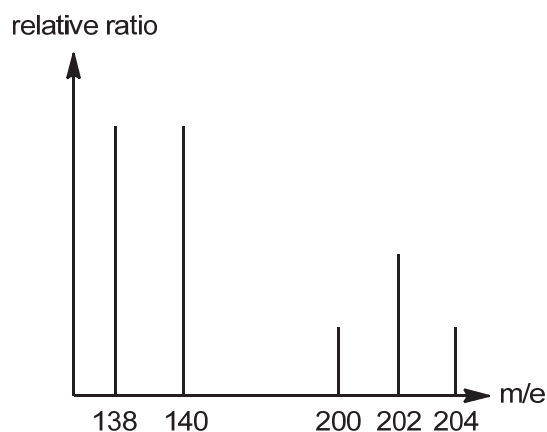

Fig 2.2: reaction with  $\text{Br}_2(\text{aq})$

- (i) Draw the structure of the product formed when propene reacts with bromine in inert organic solvent.

[1]

- (ii) Using your answer in (b)(i) and Figure 2.1, determine the isotopic composition of bromine.

You may assume that carbon, hydrogen and oxygen only exist in one isotopic form of  $^{12}\text{C}$ ,  $^1\text{H}$  and  $^{16}\text{O}$  respectively.

.....

.....

[1]

- 6 (b) (iii) Name and outline the mechanism for the reaction between propene and bromine in inert organic solvent.

Name of mechanism: .....

[4]

- (c) When propene is reacted with aqueous bromine, a different mass spectrum was obtained as shown in Fig 2.2. There are two additional peaks with greater peak height at  $m/e$  values of 138 and 140 than those at  $m/e$  values of 200 and above.

- (i) Explain, with reference to the mechanism you have described in (b)(iii), why the peaks at  $m/e$  values of 138 and 140 have greater peak height.

.....

.....

.....

.....

.....

.....

.....

.....

[2]

- 6 (c) (ii) Draw the four different possible products that are responsible for the peak at  $m/e$  value of 138 by completing the diagram below.

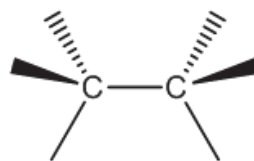
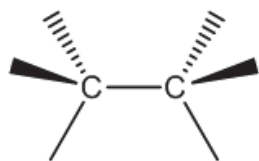
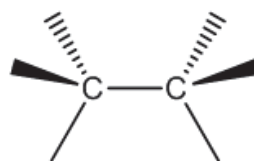
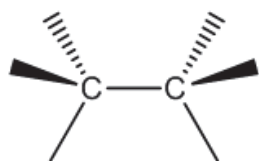

[2]

[Total: 14]

**BLANK PAGE**





JURONG JUNIOR COLLEGE  
2017 JC 2 PRELIMINARY EXAMINATION  
Higher 2

CANDIDATE  
NAME

CLASS

17S

EXAM INDEX

## CHEMISTRY

9729/03

Paper 3 Free Response

12 September 2017

2 hours

Candidates answer on separate paper.

Additional Materials:      Answer Paper  
   Data Booklet

### READ THESE INSTRUCTIONS FIRST

Write your name, class and exam index number on all the work you hand in.

Write in dark blue or black pen on both sides of the paper.

You may use a soft pencil for any diagrams, graphs or rough working.

Do not use staples, paper clips, highlighters, glue or correction fluid.

#### Section A

Answer **all** questions.

#### Section B

Answer **one** question.

A *Data Booklet* is provided.

The use of an approved scientific calculator is expected, where appropriate.

You are reminded of the need for good English and clear presentation in your answers.

The number of marks is given in brackets [ ] at the end of each question or part question.

At the end of the examination, fasten all your work securely together.

This document consists of **11** printed pages and **1** blank page.

## Section A

Answer **all** the questions in this section.

- 1 (a) (i) Describe the structure and bonding in Group 2 elements. Hence, explain why the melting point of calcium is higher than that of barium. [2]
- (ii) Samples of calcium and barium are separately added to beakers of cold water containing a few drops of litmus solution.
- Describe one observation you would make
- with calcium and barium
  - with calcium only [2]
- (b) Explain why the first ionisation energy of calcium is higher than that of potassium and gallium. [2]
- (c) Using inert electrodes, electrolysis of two separate solutions containing dilute and concentrated barium chloride respectively gives different products at the anode.
- Quote suitable  $E$  values in the *Data Booklet* and use these values to deduce the product formed at the anode for each case. Explain your answer. [4]
- (d) The salts of the Group 2 elements with divalent anions (i.e. those with a charge of 2-) usually show a decreasing trend in solubility down the group. On the other hand, most of their salts with monovalent anions are very soluble.
- Magnesium hydroxide,  $\text{Mg}(\text{OH})_2$ , is almost insoluble in water. Stirring a mixture of magnesium hydroxide and aqueous ethanedioic acid,  $\text{H}_2\text{C}_2\text{O}_4$ , produces a clear colourless solution containing **A**. When a solution of calcium nitrate,  $\text{Ca}(\text{NO}_3)_2$ , is added, a white precipitate **B** is formed.
- (i) Identify **A** and **B** and hence write balanced equations for the reactions. [2]
- The solubility product,  $K_{\text{sp}}$ , of  $\text{Mg}(\text{OH})_2$  at 298 K has a numerical value of  $2.00 \times 10^{-11}$ .
- (ii) Write an expression for the solubility product,  $K_{\text{sp}}$ , of  $\text{Mg}(\text{OH})_2$ , stating its units. [2]
- (iii) Some  $\text{Mg}(\text{OH})_2$  solid is added to pure water to obtain a saturated solution. Use the value of  $K_{\text{sp}}$  to calculate the concentration of  $\text{Mg}(\text{OH})_2$  in a saturated solution and hence its pH. [2]

- (e) The enthalpy change of solution for  $\text{Mg(OH)}_2$ ,  $\Delta H_{\text{sol}}(\text{Mg(OH)}_2(\text{s}))$  is represented by the following equation.



Using relevant data from the *Data Booklet* and the given data in the table below, construct a fully labelled energy cycle to calculate a value for the enthalpy change of solution of  $\text{Mg(OH)}_2$ ,  $\Delta H_{\text{sol}}(\text{Mg(OH)}_2(\text{s}))$ .

enthalpy change	value / $\text{kJ mol}^{-1}$
$\Delta H_{\text{f}}(\text{Mg(OH)}_2(\text{aq}))$	-922
$\Delta H_{\text{f}}(\text{OH}^{-}(\text{g}))$	-133
lattice energy of $\text{Mg(OH)}_2$	-2993
enthalpy change of atomisation of $\text{Mg}(\text{s})$	+148

[4]

**[Total: 20]**

- 2 (a) Chlorine, bromine and iodine all react with hydrogen.

With reference to suitable bond energies data in the *Data Booklet*, state and explain the trend in the reactivities of the halogens with hydrogen. [2]

- (b) (i) When aqueous bromine is added to aqueous sodium thiosulfate,  $\text{Na}_2\text{S}_2\text{O}_3$ , a sulfur-containing product is formed. Upon addition of aqueous barium nitrate, a white precipitate appears which is insoluble in excess dilute nitric acid.

Identify the white precipitate. [1]

- (ii) However, no white precipitate is formed when the same experiment in (b)(i) is repeated with aqueous iodine instead of bromine. The sulfur-containing product formed is sodium tetrathionate,  $\text{Na}_2\text{S}_4\text{O}_6$ .

By considering the change in oxidation state of sulfur, explain the difference between the reactions of the two halogens with  $\text{S}_2\text{O}_3^{2-}$ . [2]

- (c) Silver chloride,  $\text{AgCl}$ , and silver iodide,  $\text{AgI}$ , are sparingly soluble in water.

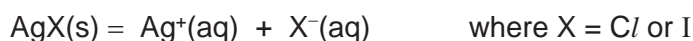

Upon addition of excess aqueous ammonia,  $\text{AgCl}$  dissolves completely but  $\text{AgI}$  hardly dissolves. Explain these observations. [2]

- (d) When reacted with chlorine under suitable conditions, 2-methylbenzaldehyde forms compound **C**.

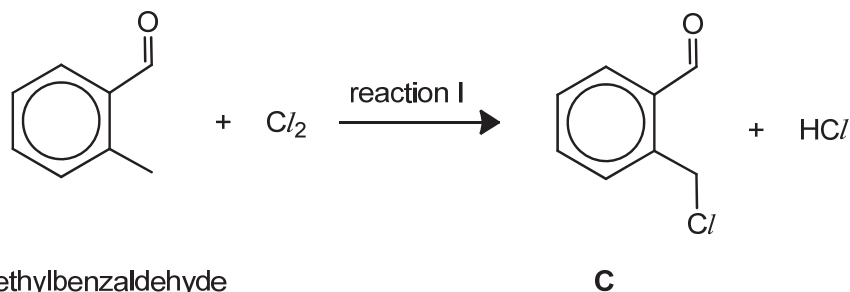

- (i) Name and describe the mechanism for reaction I. You may show all the bonds in the methyl group in your mechanism. [4]

**C** undergoes further reactions to form compound **F**.

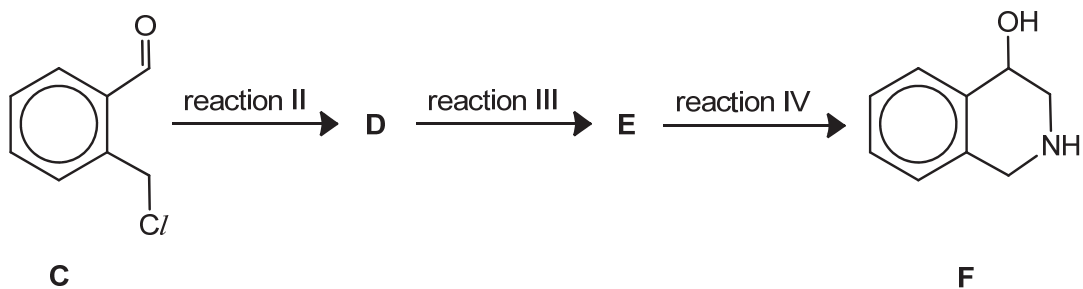

(ii) Suggest reagents and conditions for reactions II to IV. [3]

(iii) Draw the structures of **D** and **E**. [2]

(iv) Alkane **G**,  $C_6H_{14}$ , undergoes a similar reaction as 2-methylbenzaldehyde with chlorine and produces **only three** monochlorinated constitutional isomers, **H**, **J** and **K**.

**H** exhibits stereoisomerism whereas **J** and **K** do not.

Suggest the type of stereoisomerism present in **H** and explain what feature is present in **H** that gives rise to this stereoisomerism.

Suggest the structures of **G** and **H**. [4]

[Total: 20]

3 The name of the element, *chromium*, means colour in Greek because many chromium compounds are intensely coloured.

(a) State the full electronic configuration of a chromium atom in its ground state. [1]

(b) Chromium ions tend to form octahedral complexes.

In an octahedral complex, ligands cause the five degenerate *d* orbitals of the chromium ion to be split into two energy levels.

(i) Using Cartesian axes, like those shown in Figure 3.1, draw **fully-labelled** diagrams of the following.

- One of the *d* orbitals at the lower energy level in an octahedral complex. Label this diagram as “**lower energy**”.
- One of the *d* orbitals at the higher energy level in an octahedral complex. Label this diagram as “**higher energy**”.

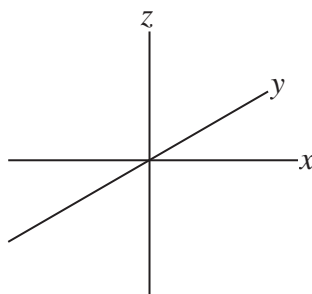

Figure 3.1

[2]

(ii) Hence, explain how the colour of chromium complexes arises. [2]

(c) Due to its ability to vary its oxidation state, chromium compounds tend to undergo redox reaction readily.

$\text{Cr}_2\text{O}_7^{2-}$  and  $\text{CrO}_4^{2-}$  ions are the oxoanions of chromium in its highest oxidation state of +6. In aqueous solution,  $\text{Cr}_2\text{O}_7^{2-}$  and  $\text{CrO}_4^{2-}$  ions are interconvertible since they exist in a chemical equilibrium as shown below.

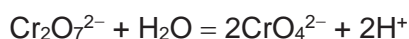

(i) In acidic medium, the predominant species is  $\text{Cr}_2\text{O}_7^{2-}$  while in alkaline medium, it is  $\text{CrO}_4^{2-}$ .

Explain why, in alkaline medium, the predominant species is  $\text{CrO}_4^{2-}$ . [1]

(ii) Both  $\text{Cr}_2\text{O}_7^{2-}$  and  $\text{CrO}_4^{2-}$  ions are moderately strong oxidising agents. When reduced, green  $\text{Cr}^{3+}$  solution was formed in acidic medium but in alkaline medium, grey-green  $\text{Cr}(\text{OH})_3$  precipitate was formed.

Write an ion–electron equation for the reduction of  $\text{CrO}_4^{2-}$  to  $\text{Cr}(\text{OH})_3$ . [2]

- (iii) When a solution of  $\text{CrO}_4^{2-}$  is reacted with 0.300 mol of an appropriate reducing agent, 0.200 mol of  $\text{Cr}(\text{OH})_3$  was formed.

Using your answer in (c)(ii), together with the following data, calculate  $E_{\text{cell}}$  and standard electrode potential for  $\text{CrO}_4^{2-}/\text{Cr}(\text{OH})_3$ .

$$\begin{array}{ll} \text{standard Gibbs free energy change of the reaction, } \Delta G^\circ & = -365 \text{ kJ mol}^{-1} \\ \text{standard electrode potential of the reducing agent} & = -0.76 \text{ V} \end{array} \quad [3]$$

- (iv) Hence, using relevant data from the *Data Booklet*, explain how this value in (c)(iii) relates to the relative oxidising power of the two chromium(VI) compounds. [1]

- (d) Similar to  $\text{Cr}_2\text{O}_7^{2-}$ , compounds containing  $\text{MnO}_4^-$  ions are commonly used in organic synthesis as good oxidising agents.

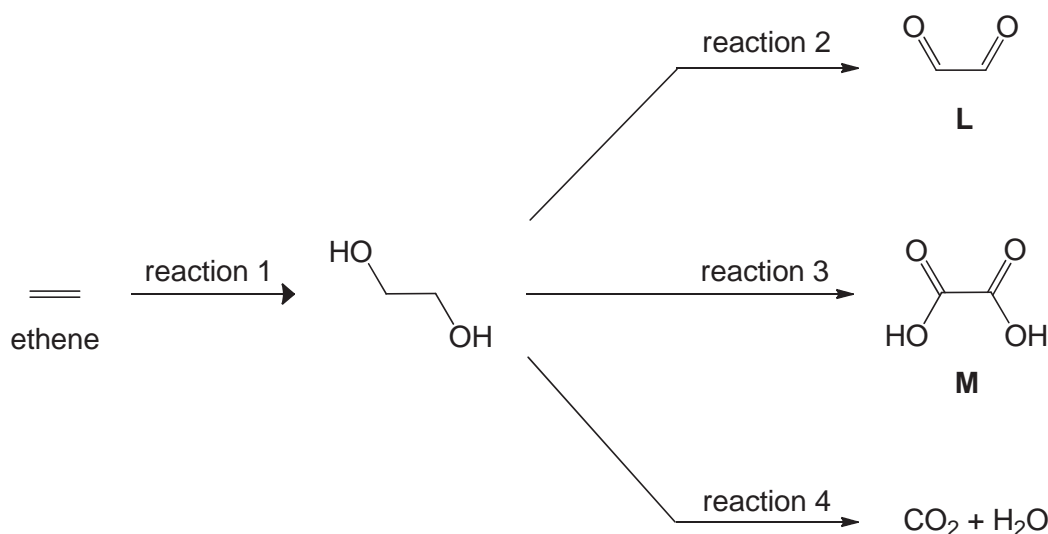

- (i) State the necessary reagents and condition for reaction 1 to 4. [4]
- (ii) A sodium salt of **M** was added to an aqueous solution of  $\text{CrCl}_3$ , and a six-coordinate complex ion,  $[\text{Cr}(\text{C}_2\text{O}_4)_3]^{3-}$ , was formed.

Draw the structure of this complex ion, showing clearly the shape around chromium. [1]

- (e) In the production of approximately half of the world's polyethylene, a chromium oxide containing catalyst, also known as the Phillips catalyst, was used in the polymerisation of ethene.

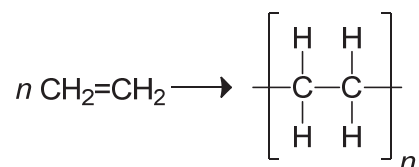

State the **type** of catalysis involved in this reaction.

Describe how this **type** of catalyst speeds up the reaction. [3]

[Total: 20]

## Section B

Answer **one** question from this section.

- 4 The Aldol Addition reaction is important in organic synthesis as it provides a method for linking two smaller molecules by introducing a carbon–carbon bond between them.

The reaction combines two carbonyl compounds to form a new  $\beta$ -hydroxy carbonyl compound, also known as *aldols*, which are commonly found in many important molecules, whether naturally occurring or synthetic.

One example of Aldol Addition reaction is shown in the equation below.

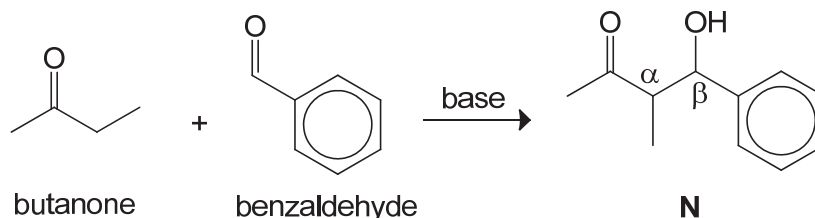

The following shows the mechanism for the Aldol Addition reaction involving butanone and benzaldehyde.

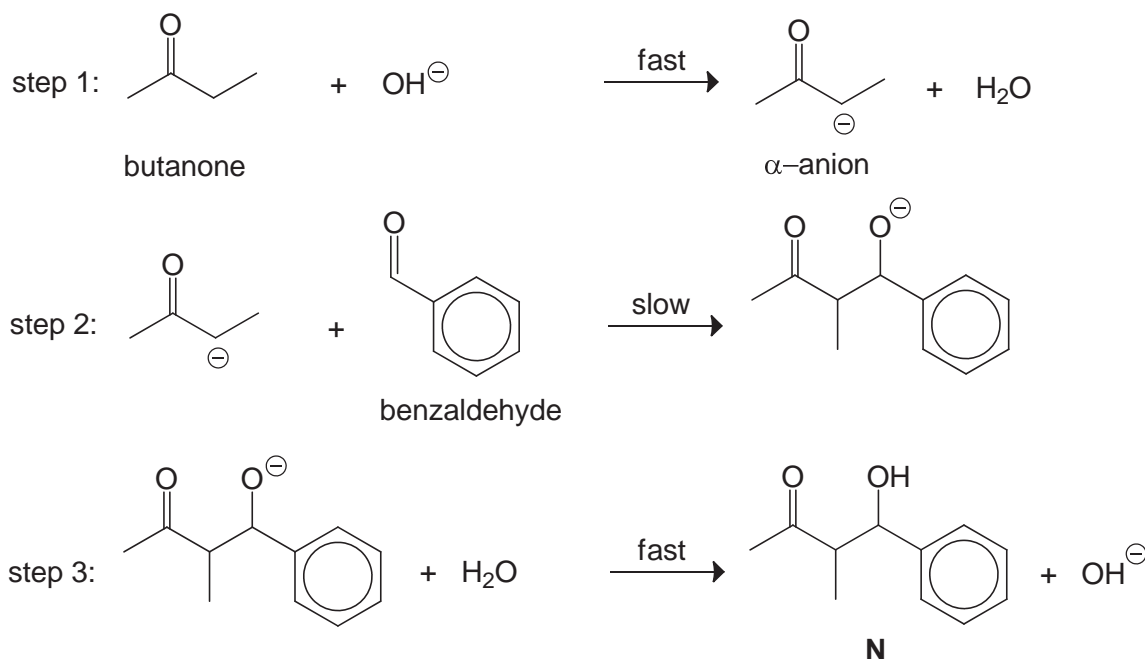

- (a) (i) State the type of reaction that has occurred during step 1 of the mechanism. [1]
- (ii) By considering the stability of the anion, explain why the  $\alpha$ -anion is predominantly formed in step 1, instead of the  $\beta$ -anion as shown below.

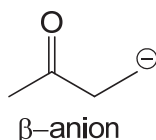

[2]

- (iii) State the role of the  $\alpha$ -anion in step 2 of the mechanism. [1]

- (iv) Copy the equations for steps 2 and 3 shown above and complete the mechanism by showing the movement of electron pairs using curly arrows. Indicate all charges and relevant lone pairs. [2]



By either adjusting the reaction temperature or using a stronger base, butanone and benzaldehyde can undergo Aldol Condensation reaction, forming compound **P** as shown below.

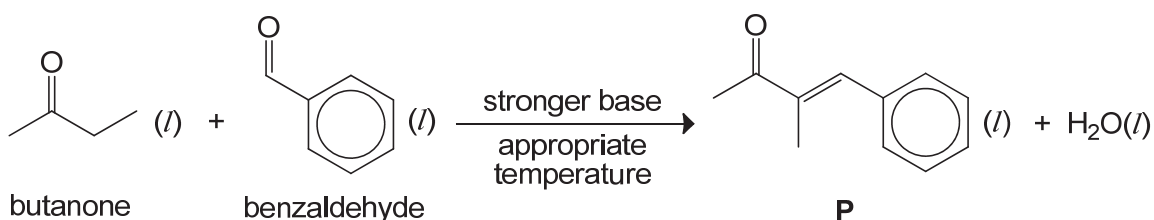

- (b) (i) Using bond energies data in the *Data Booklet*, calculate the enthalpy change for this Aldol Condensation reaction. [2]
- (ii) The actual enthalpy change for the Aldol Condensation reaction between butanone and benzaldehyde is **much** more endothermic than that in (b)(i). Suggest **two** reasons to account for this difference in value. [2]
- (iii) Given that there is an increase in the entropy of the reaction, state and explain whether the Aldol Condensation reaction is favoured by a low or high reaction temperature. [2]
- (iv) Suggest a simple chemical test that could be carried out to see if compound **P** is formed. [2]
- (c) (i) State the Lewis theory of acids and bases. [1]
- (ii) Predict, with reasoning, which base,  $\text{OH}^-$  or  $\text{CH}_3\text{CH}_2\text{O}^-$ , would favour the Aldol Condensation reaction. [2]
- (d) Intramolecular Aldol Condensation reaction can also occur to give a cyclic unsaturated carbonyl compound when a dicarbonyl compound with a sufficiently long carbon chain is used. An example of such a reaction is given below.

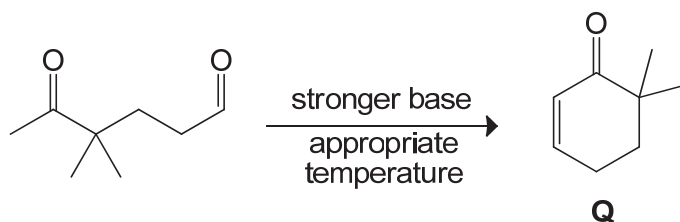

- (i) State a value for the  $\text{C}=\text{C}-\text{C}$  bond angle in **Q**. [1]
- (ii) Hence suggest why the expected cyclisation does **not** occur when the following dicarbonyl compound was used. [1]
- 
- CC(C)(C)CC(=O)C=O
- (iii) Hence draw the structure of the unsaturated carbonyl product formed when the compound in (d)(ii) was used. [1]

[Total: 20]

5 An oxocarbon is a chemical compound consisting of only carbon and oxygen atoms, with carbon monoxide and carbon dioxide being the most common oxocarbons.

(a) Carbon monoxide is one of the most widespread and dangerous industrial hazards due to the formation of carboxyhaemoglobin,  $\text{Hb}(\text{CO})_4$ , which occurs much more readily than the formation of oxyhaemoglobin,  $\text{Hb}(\text{O}_2)_4$ .

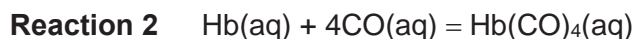
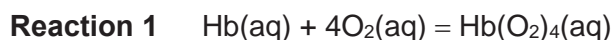

(i) Draw separate dot-and-cross diagrams for carbon monoxide and oxygen.

Hence, explain why the formation of carboxyhaemoglobin occurs much more readily than that of oxyhaemoglobin [3]

(ii) Treatment of severe carbon monoxide poisoning requires oxygen therapy which provides pure oxygen to the patient.

With reference to the equations given above, explain how oxygen therapy works in the treatment of carbon monoxide poisoning [2]

(b) The water-gas shift reaction (WGS) is an industrial method to produce hydrogen gas, by reacting carbon monoxide with water vapour, which is an important reagent in industrial processes such as the production of ammonia gas in Haber process.

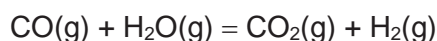

(i) State two assumptions of the kinetic theory of an ideal gas. [2]

(ii) A  $500 \text{ cm}^3$  evacuated vessel was initially filled with  $2.0 \times 10^{-4}$  mol of  $\text{CO}(\text{g})$  and  $4.0 \times 10^{-4}$  mol of  $\text{H}_2\text{O}(\text{g})$  at 600 K. The vessel was sealed and left to stand. At equilibrium, the percentage yield of  $\text{H}_2$  was found to be 97 %.

Using the ideal gas equation, calculate the equilibrium partial pressure of  $\text{H}_2$ . [1]

(iii) Comment whether the use of the ideal gas equation in (b)(ii) is valid. [1]

(iv) Write an expression for the equilibrium constant,  $K_p$ , for the WGS reaction and state the units. [2]

(v) Using your answer in (b)(ii), calculate a value of  $K_p$  for the WGS reaction that occurred at 600 K, expressing your answer to **two** significant figures. [2]

- (c) Phosgene,  $\text{COCl}_2$ , is a valued industrial reagent used in the synthesis of pharmaceuticals and other organic compounds. It can be produced by passing purified carbon monoxide and chlorine gas through a bed of porous activated carbon, which serves as a catalyst.

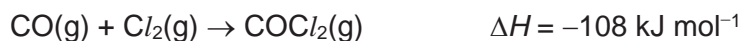

Typically, the reaction is conducted between 50 °C and 150 °C. Above 200 °C, phosgene reverts to carbon monoxide and chlorine.

- (i) Predict and explain the sign of  $\Delta S$  for the production of phosgene. [1]
- (ii) Use your answer in (c)(i) and the information given, deduce whether the production of phosgene is enthalpy driven or entropy driven. [1]
- (iii) Phosgene is sensitive towards moisture and will give an acidic solution in the presence of moisture. Write an equation to illustrate this reaction. [1]
- (d) When reacted with aqueous sodium carbonate, 1 mole of an aromatic compound **R**,  $\text{C}_{12}\text{H}_6\text{O}_{12}$ , produces 72 dm<sup>3</sup> of carbon dioxide measured at room temperature and pressure.

Heating **R** with appropriate reagent for several hours produces a sweet-smelling compound **S**,  $\text{C}_{12}\text{O}_9$ , which is symmetrical.

Deduce the structures for compounds **R** and **S**, explaining the chemistry of the reactions involved. [4]

[Total: 20]

**BLANK PAGE**



**JURONG JUNIOR COLLEGE**  
**2017 JC 2 PRELIMINARY EXAMINATION**  
**Higher 2**

CANDIDATE  
NAME

CLASS

17S

EXAM INDEX

**CHEMISTRY**

**9729/04**

Paper 4 Practical

**17 August 2017**  
**2 hours 30 minutes**

Candidates answer on the Question paper.

Additional Materials: As listed in the Confidential Instructions

**READ THESE INSTRUCTIONS FIRST**

Write your name, class and exam index number on all the work you hand in.  
Give details of the practical shift and laboratory where appropriate, in the boxes provided.  
Write in dark blue or black pen.  
You may use a HB pencil for any diagrams, graphs.  
Do not use staples, paper clips, glue or correction fluid.

Answer **all** questions in the spaces provided on the Question Paper.

The use of an approved scientific calculator is expected, where appropriate.  
You may lose marks if you do not show your working or if you do not use appropriate units.

Qualitative Analysis Notes are printed on pages 19 and 20.

At the end of the examination, fasten all your work securely together.  
The number of marks is given in brackets [ ] at the end of each question or part question.

<b>Shift</b>
<b>Laboratory</b>

For Examiner's Use	
1	13
2	16
3	20
4	6
Total	55

This document consists of **20** printed pages and **2** blank pages.

Answer **all** the questions in the spaces provided.

### 1 Determination of the percentage by mass of iron(II) sulfate in mixture

**FA 1** is an aqueous solution containing a mixture of iron(II) sulfate,  $\text{FeSO}_4$  and iron(III) sulfate,  $\text{Fe}_2(\text{SO}_4)_3$ .

In the presence of acid, the iron(II) sulfate is oxidised by potassium manganate(VII).



**FA 1** is an aqueous solution containing  $215.0 \text{ g dm}^{-3}$  of a mixture of iron(II) sulfate,  $\text{FeSO}_4$  and iron(III) sulfate,  $\text{Fe}_2(\text{SO}_4)_3$ .

**FA 2** is  $2.00 \text{ g dm}^{-3}$  potassium manganate(VII),  $\text{KMnO}_4$ .

**FA 3** is  $1.00 \text{ mol dm}^{-3}$  sulfuric acid,  $\text{H}_2\text{SO}_4$ .

In this question, you will perform a dilution followed by a titration. The data from this titration will be used to determine:

- the concentration of  $\text{FeSO}_4$  in **FA 1**,
- the percentage by mass of  $\text{FeSO}_4$  in the mixture used to prepare **FA 1**.

#### (a) (i) Dilution of FA 1

1. Pipette  $25.0 \text{ cm}^3$  of **FA 1** into the  $250 \text{ cm}^3$  volumetric flask.
2. Make up the contents of the flask to the  $250 \text{ cm}^3$  mark with deionised water.
3. Place the stopper in the flask and mix the contents thoroughly by slowly inverting the flask a number of times.
4. Label this diluted solution of iron(II) sulfate and iron(III) sulfate **FA 4**.

#### Titration of FA 4 against FA 2

1. Fill a burette with **FA 2**.
2. Rinse the pipette thoroughly with deionised water and then with a little **FA 4**.
3. Pipette  $25.0 \text{ cm}^3$  of **FA 4** into the conical flask.
4. Using an appropriate measuring cylinder, transfer  $10.0 \text{ cm}^3$  of **FA 3** to the same conical flask.
5. Run **FA 2** from the burette into this flask until the first **permanent** pale pink colour is obtained.
6. Record your titration results in the space provided on page 3. Make certain that your recorded results show the precision of your working.
7. Repeat points 1 to 6 as necessary until consistent results are obtained.

## Results

For  
Examiner's  
Use

[6]

- (ii) From your titrations, obtain a suitable volume of **FA 2** to be used in your calculations. Show clearly how you obtained this volume.

Volume of **FA 2** = ..... [1]

- (b) (i) Calculate the amount of  $\text{KMnO}_4$  present in the volume calculated in (a)(ii).

[Ar: O, 16.0; K, 39.1; Mn, 54.9]

Amount of  $\text{KMnO}_4$  = ..... [1]

- (ii) Calculate the concentration, in  $\text{mol dm}^{-3}$ , of  $\text{FeSO}_4$  in **FA 4**.

Concentration of  $\text{FeSO}_4$  in **FA 4** = ..... [1]

- (iii) Calculate the concentration, in  $\text{mol dm}^{-3}$ , of  $\text{FeSO}_4$  in **FA 1**.

Concentration of  $\text{FeSO}_4$  in **FA 1** = ..... [1]

- (iv) **FA 1** is an aqueous solution containing  $215.0 \text{ g dm}^{-3}$  of a mixture of  $\text{FeSO}_4$  and  $\text{Fe}_2(\text{SO}_4)_3$ .

Hence, calculate the percentage, by mass, of  $\text{FeSO}_4$  in this mixture.

[Ar: O, 16.0; S, 32.1; Fe, 55.8]

Percentage by mass of  $\text{FeSO}_4$  in mixture = ..... [1]



- (c) The maximum error for a  $25.0 \text{ cm}^3$  pipette commonly used in schools is  $\pm 0.06 \text{ cm}^3$ .

The maximum error in any single burette reading is  $\pm 0.05 \text{ cm}^3$ .

Calculate the maximum percentage error in each of the following.

- (i) The volume of **FA 4** pipetted into the conical flask.

Maximum % error = .....

- (ii) The volume of **FA 2** used in (a)(ii).

Maximum % error = ..... [2]

[Total: 13]



- 2 In this experiment you will investigate how the rate of reaction between sodium thiosulfate and sulfuric acid is affected by the concentration of sodium thiosulfate.

When aqueous thiosulfate ions react with hydrogen ions,  $\text{H}^+$ , in any acid, a pale yellow precipitate of sulfur is formed. The ionic equation for this reaction is given below.

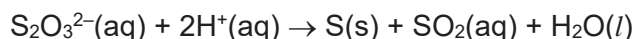

The rate of the reaction can be determined by measuring the time taken to produce a fixed quantity of sulfur.

**FA 5** is  $37.0 \text{ g dm}^{-3}$  hydrated sodium thiosulfate,  $\text{Na}_2\text{S}_2\text{O}_3 \cdot 5\text{H}_2\text{O}$

You will need access to the **FA 3** solution you used earlier.

The order of reaction with respect to thiosulfate ions can be obtained by plotting a graph of log rate against log (volume of  $\text{S}_2\text{O}_3^{2-}$ ).

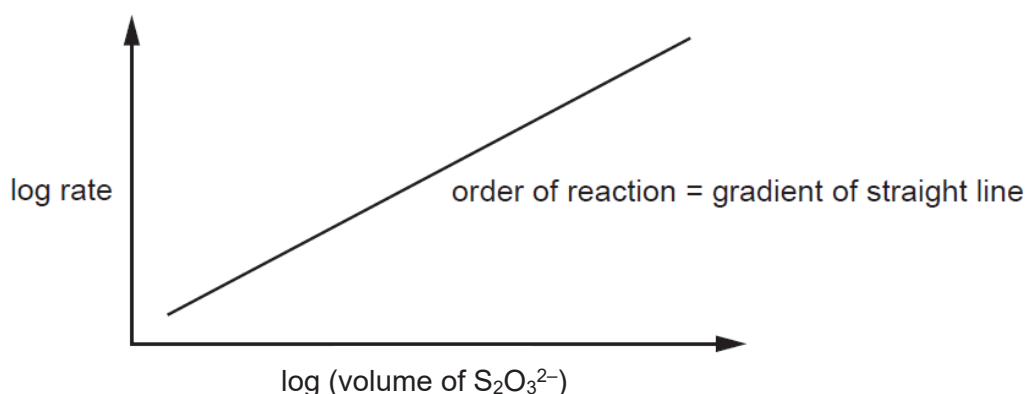

You are advised to read the instructions before starting any practical work.

(a) **Method**

**Experiment 1**

- Use an appropriate measuring cylinder, transfer  $50.0 \text{ cm}^3$  of **FA 5** into a  $250 \text{ cm}^3$  beaker.
- Measure  $5.0 \text{ cm}^3$  of **FA 3** in an appropriate measuring cylinder.
- Tip the acid **FA 3** from the measuring cylinder into the beaker and start timing **immediately**.
- Swirl the beaker to mix the reagents and place the beaker on top of the printed insert page provided. (Detach the last page)
- Look down through the solution in the beaker at the print on the insert
- Stop timing as soon as the precipitate of sulfur makes the print on the insert invisible.
- Record the time taken,  $t$ , to the **nearest second**.
- Empty and rinse the  $250 \text{ cm}^3$  beaker.
- Dry the outside of the beaker ready for Experiment 2.

**Experiment 2**

- Use the measuring cylinder for **FA 5** in Experiment 1 to transfer 10.0 cm<sup>3</sup> of **FA 5** into the rinsed and dried beaker.
- Use the same measuring cylinder for **FA 5** to transfer 40.0 cm<sup>3</sup> of deionised water into the same beaker.
- Measure 5.0 cm<sup>3</sup> of **FA 3** in an appropriate measuring cylinder.
- Tip the acid **FA 3** from the measuring cylinder into the beaker and start timing **immediately**.
- Swirl the beaker to mix the reagents and place the beaker on top of the printed insert page provided.
- Look down through the solution in the beaker at the print on the insert.
- Stop timing as soon as the precipitate of sulfur makes the print on the insert invisible.
- Record the time taken,  $t$ , to the **nearest second**.
- Empty and rinse the 250 cm<sup>3</sup> beaker.
- Dry the outside of the beaker ready for Experiment 3.

**Experiments 3 – 5**

Carry out three more experiments to investigate the order of reaction with respect to thiosulfate ions. The volume of **FA 5** should not be less than those in Experiment 2. Deionised water is added to keep the total volume of the final reaction mixture constant.

**When you have completed all of your experiments, empty and rinse the beaker.**

Prepare a table in the space provided to record, for each experiment

- all volumes
- the value of  $t$ , to the nearest second
- calculated value of  $\log (1/t)$  and  $\log (\text{volume of FA 5})$  respectively, to 3 significant figures

**Results:**

- (b) Use the grid below to plot a graph of **log (1/time)** against **log (volume of FA 5)**.  
Draw an appropriate straight line through the points plotted.

For  
Examiner's  
Use

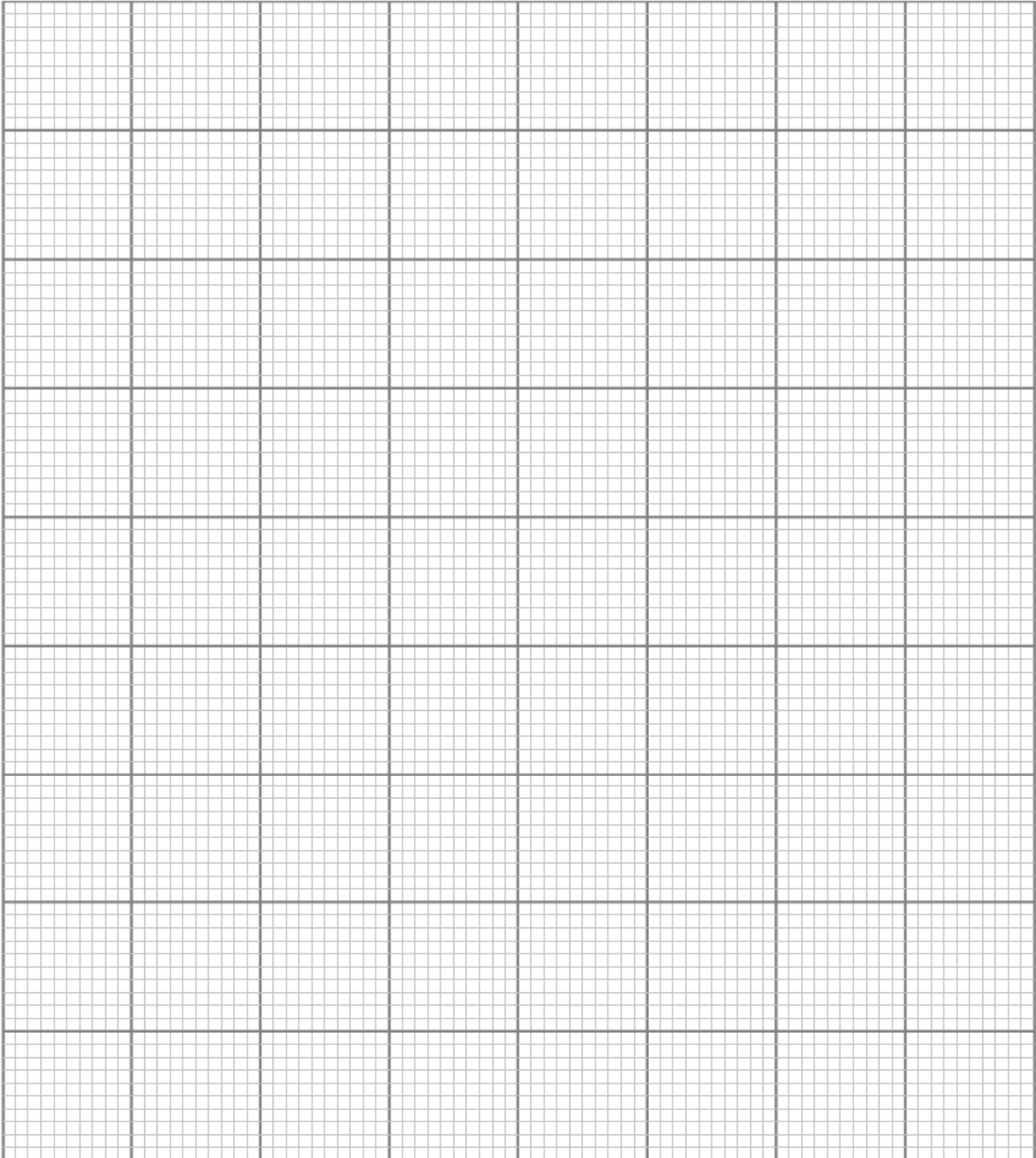

[3]

- (c) Draw construction lines on your graph and obtain data from them to enable you to calculate the gradient of the graph.

Hence, determine the order of reaction with respect to thiosulfate ions.

The reaction is ..... order with respect to  $\text{S}_2\text{O}_3^{2-}$ . [5]

- (d) The experimental method can be modified to enable the rate of reaction with respect to hydrogen ions,  $\text{H}^+$ , to be investigated.

In the first line of the table below, the volumes of **FA 5**, deionised water and **FA 3** used in **Experiment 2** are recorded.

Complete the following table, suggesting volumes for each of the reagents that could be used in two further experiments to investigate how the rate of reaction varies with a change in volume of sulfuric acid, **FA 3**.

**Do not carry out this experiment.**

Experiment	Volume of <b>FA 5</b> / $\text{cm}^3$	Volume of deionised water/ $\text{cm}^3$	Volume of <b>FA 3</b> / $\text{cm}^3$
<b>2</b>	10.0	40.0	5.0
<b>(i)</b>			
<b>(ii)</b>			

[1]

- (e) A student concluded that the reaction is first order with respect to hydrogen ions,  $\text{H}^+$ .

Predict how the reaction time measured in **Experiment 2** would have been affected if the following modifications are made to the experiment separately.

For each case, explain your answer.

- (i) The experiment had been carried out using  $1.0 \text{ mol dm}^{-3}$  hydrochloric acid instead of  $1.0 \text{ mol dm}^{-3}$  sulfuric acid. [1]

.....  
 .....  
 .....

- (ii) The experiment had been carried out in a  $100 \text{ cm}^3$  beaker instead of a  $250 \text{ cm}^3$  beaker. [1]

.....  
 .....  
 .....

[Total: 16]

### 3 Qualitative Analysis

At each stage of any test, you are to record details of the following

- colour changes seen
- the formation of any precipitate
- the solubility of such precipitate in an excess of the reagent added.

Where gases are released they should be identified by a test, **described in the appropriate place in your observations.**

You should indicate clearly at what stage in a test a change occurs.

**No additional tests for ions present should be attempted.**

**If any solution is warmed, a boiling tube MUST be used.**

Rinse and reuse test-tubes and boiling tubes where possible.

**Where reagents are selected for use in a test, the name or correct formula of the element or compound must be given.**

(a) **FA 6** is a solid and **FA 7** is a solution. **Some** of the ions in **FA 6** and **FA 7** are listed in the Qualitative Analysis notes on pages 19 and 20.

- (i) Place a **small** spatula measure of **FA 6** into a **hard-glass** test-tube.  
Heat gently at first and then strongly, until no further change is observed.  
Test with litmus papers while you are heating.  
Record all your observations below.

.....  
.....  
.....  
.....  
.....

[2]

- (ii) Place two spatula measures of **FA 6** into a boiling-tube. Dissolve the solid in about 5 cm depth of distilled water. Use this **FA 6** solution together with the **FA 7** solution provided for the following tests.

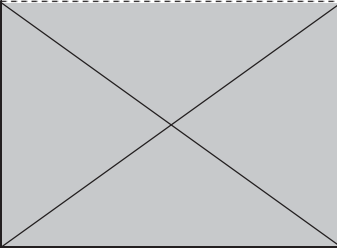
<i>test</i>	<i>observations</i>	
	<b>FA 6</b>	<b>FA 7</b>
1. To a 0.5 cm depth of solution in a boiling tube add aqueous sodium hydroxide, then		
Warm gently.		
Allow to cool, add a piece of aluminium foil and warm again.		
2. To a 1 cm depth of solution in at test-tube add a 1 cm depth of dilute sulfuric acid followed by a few drops of aqueous potassium manganate(VII).		
3. To a 1 cm depth of solution in at test-tube add a 2 cm depth of hydrogen peroxide and leave to stand.		
4. To a 1 cm depth of solution in at test-tube add a 1 cm depth of dilute hydrochloric acid, then		
Add a 1 cm depth of aqueous barium nitrate.		

[7]



- (b) (i) Identify as many ions present in **FA 6** and **FA 7** as possible from your observations.

If an ion cannot be identified from the tests, write 'unknown' in the space.

	cation(s)	anion(s)
<b>FA 6</b>		
<b>FA 7</b>		

[2]

- (ii) Describe another test you could carry out to confirm the identity of a cation you have identified in (i). Record the reagent(s) and expected observation(s) in the space below.

**Do not carry out this test.**

.....

.....

.....

.....

[2]

- (iii) Write an ionic equation for the reaction that would occur in (ii). Include state symbols.

.....

[1]

**(c) Planning**

Consider the following organic compounds.

benzaldehyde     2-methylpropan-2-ol     propan-2-ol     propanone

Plan an investigation, using test-tube reactions, **other** than using 2,4-dinitrophenylhydrazine reagent which would allow you to identify each of these four organic compounds.

Each compound should be identified by at least one positive test result. It is **not** sufficient to identify a compound simply by eliminating all the others.

Your plan should include:

- details of the reagents and conditions to be used,
- an outline of the sequence of steps you would follow,
- an explanation of how you would analyse your results in order to identify each compound.

Once a compound has been clearly identified, your plan should concentrate on distinguishing the remaining compounds.

.....

.....

.....

.....

.....

.....

.....

.....

.....

.....

.....

.....

.....

.....

.....

.....

.....

.....

.....

.....

.....

.....

.....

.....

.....



#### 4. Planning

Copper has two oxides,  $\text{Cu}_2\text{O}$  and  $\text{CuO}$ . Copper(II) carbonate,  $\text{CuCO}_3$ , decomposes on heating to form one of these oxides. Separate equations can be written showing the two possible decompositions.

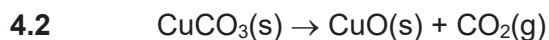

You are to plan an experiment to investigate the decomposition of copper(II) carbonate on heating and hence decide which of the two equations represents the actual decomposition by collection of gas in the experiment.

- (a) Draw a diagram of the apparatus and experimental set up you would use in the experiment.

Your apparatus should use only standard items found in a school or college laboratory and should show clearly

- how the copper(II) carbonate will be heated,
- how the volume of the gas evolved will be collected and measured.

Label each piece of apparatus used, indicating its size or capacity.

(b) You are required to write a plan to determine which equation represents the actual decomposition of copper(II) carbonate

You may assume that you are provided with a sample of copper(II) carbonate

Your plan should include:

- calculation of the mass of copper(II) carbonate that will produce the maximum volume of gas that can be collected based on the capacity of the apparatus you have indicated in (a) for each equation when you are heating the solid.

(You may assume that the molar gas volume at the temperature in the apparatus used for gas collection stays constant at  $25.3 \text{ dm}^3$  throughout the heating process.)

- practical details of how you would
  - determine the mass of copper(II) carbonate used in the experiment;
  - ensure the completion of the decomposition;
  - determine the volume of gas that has been collected.
- brief, but specific, details of how the results would then be used to reach a conclusion.

[Ar : C, 12.0; O, 16.0; Cu, 63.5]

.....

.....

.....

.....

.....

.....

.....

.....

.....

.....

.....

.....

.....

.....

.....

.....

.....

.....

.....

.....

.....

.....



## Qualitative Analysis Notes

[ppt. = precipitate]

### (a) Reactions of Aqueous Cations

<i>cation</i>	<i>Reaction with</i>	
	NaOH(aq)	NH <sub>3</sub> (aq)
aluminium, Al <sup>3+</sup> (aq)	white ppt. soluble in excess	white ppt. insoluble in excess
ammonium, NH <sub>4</sub> <sup>+</sup> (aq)	ammonia produced on heating	–
barium, Ba <sup>2+</sup> (aq)	no ppt. (if reagents are pure)	no ppt.
calcium, Ca <sup>2+</sup> (aq)	white ppt. with high [Ca <sup>2+</sup> (aq)]	no. ppt.
chromium(III), Cr <sup>3+</sup> (aq)	grey–green ppt. soluble in excess giving dark green solution	grey–green ppt. insoluble in excess
copper(II), Cu <sup>2+</sup> (aq)	pale blue ppt. insoluble in excess	blue ppt. soluble in excess giving dark blue solution
iron(II), Fe <sup>2+</sup> (aq)	green ppt. turning brown on contact with air insoluble in excess	green ppt. turning brown on contact with air insoluble in excess
iron(III), Fe <sup>3+</sup> (aq)	red–brown ppt. insoluble in excess	red–brown ppt. insoluble in excess
magnesium, Mg <sup>2+</sup> (aq)	white ppt. insoluble in excess	white ppt. insoluble in excess
manganese(II), Mn <sup>2+</sup> (aq)	off–white ppt. rapidly turning brown on contact with air insoluble in excess	off–white ppt. rapidly turning brown on contact with air insoluble in excess
zinc, Zn <sup>2+</sup> (aq)	white ppt. soluble in excess	white ppt. soluble in excess

**(b) Reactions of Aqueous Anions**

<b>Anion</b>	<b>Reaction</b>
carbonate, $\text{CO}_3^{2-}$	$\text{CO}_2$ liberated by dilute acids
chloride, $\text{Cl}^-(\text{aq})$	gives white ppt. with $\text{Ag}^+(\text{aq})$ (soluble in $\text{NH}_3(\text{aq})$ );
bromide, $\text{Br}^-(\text{aq})$	gives pale cream ppt. with $\text{Ag}^+(\text{aq})$ (partially soluble in $\text{NH}_3(\text{aq})$ );
iodide, $\text{I}^-(\text{aq})$	gives yellow ppt. with $\text{Ag}^+(\text{aq})$ (insoluble in $\text{NH}_3(\text{aq})$ );
nitrate, $\text{NO}_3^-(\text{aq})$	$\text{NH}_3$ liberated on heating with $\text{OH}^-(\text{aq})$ and Al foil
nitrite, $\text{NO}_2^-(\text{aq})$	$\text{NH}_3$ liberated on heating with $\text{OH}^-(\text{aq})$ and Al foil; $\text{NO}$ liberated by dilute acids (colourless $\text{NO} \rightarrow$ (pale) brown $\text{NO}_2$ in air)
sulfate, $\text{SO}_4^{2-}(\text{aq})$	gives white ppt. with $\text{Ba}^{2+}(\text{aq})$ (insoluble in excess dilute strong acids)
sulfite, $\text{SO}_3^{2-}(\text{aq})$	$\text{SO}_2$ liberated on warming with dilute acids; gives white ppt. with $\text{Ba}^{2+}(\text{aq})$ (soluble in excess dilute strong acids)

**(c) Tests for Gases**

<b>gas</b>	<b>Test and test results</b>
ammonia, $\text{NH}_3$	turns damp red litmus paper blue
carbon dioxide, $\text{CO}_2$	gives a white ppt. with limewater (ppt. dissolves with excess $\text{CO}_2$ )
chlorine, $\text{Cl}_2$	bleaches damp litmus paper
hydrogen, $\text{H}_2$	"pops" with a lighted splint
oxygen, $\text{O}_2$	relights a glowing splint
sulfur dioxide, $\text{SO}_2$	turns acidified aqueous potassium manganate(VII) from purple to colourless

**(d) Colour of halogens**

<b>halogen</b>	<b>colour of element</b>	<b>colour in aqueous solution</b>	<b>colour in hexane</b>
chlorine, $\text{Cl}_2$	greenish yellow gas	pale yellow	pale yellow
bromine, $\text{Br}_2$	reddish brown gas/liquid	orange	orange-red
iodine, $\text{I}_2$	black solid/purple gas	brown	purple



INSERT

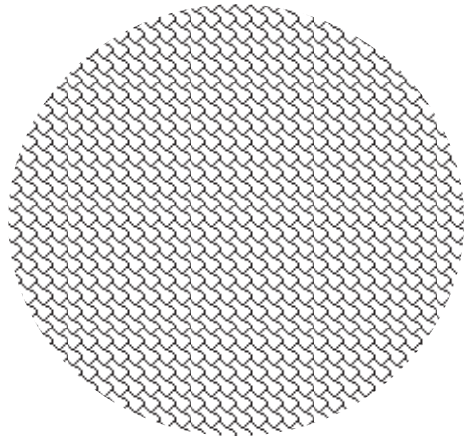

BLANK PAGE

**Answers for 2017 JJC Prelim Paper 1 (9729/01)**

1	<b>C</b>	6	<b>D</b>	11	<b>A</b>	16	<b>B</b>	21	<b>A</b>	26	<b>B</b>
2	<b>D</b>	7	<b>C</b>	12	<b>D</b>	17	<b>A</b>	22	<b>D</b>	27	<b>A</b>
3	<b>A</b>	8	<b>C</b>	13	<b>D</b>	18	<b>A</b>	23	<b>D</b>	28	<b>B</b>
4	<b>C</b>	9	<b>B</b>	14	<b>D</b>	19	<b>B</b>	24	<b>B</b>	29	<b>A</b>
5	<b>D</b>	10	<b>D</b>	15	<b>C</b>	20	<b>C</b>	25	<b>A</b>	30	<b>C</b>

**Suggested Mark Scheme for 2017 JJC Prelim Exam Paper 2 (9729/02)**

1 (a)

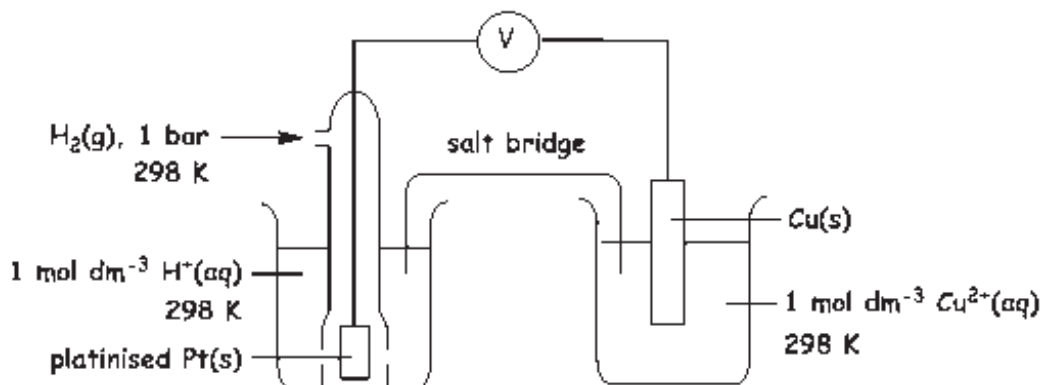

- (b) From Data Booklet:
- |  |         |
|--|---------|
| $\text{Cu}^{2+} + 2\text{e}^- = \text{Cu}$ | +0.34 V |
| $\text{Ag}^+ + \text{e}^- = \text{Ag}$     | +0.80 V |
| $\text{Zn}^{2+} + 2\text{e}^- = \text{Zn}$ | -0.76 V |

At the anode, Cu dissolves.

Since  $E(\text{Zn}^{2+}/\text{Zn})$  is less positive than  $E(\text{Cu}^{2+}/\text{Cu})$ , zinc impurities dissolve into solution.

Since  $E(\text{Ag}^+/\text{Ag})$  is more positive than  $E(\text{Cu}^{2+}/\text{Cu})$ , the silver impurities will not dissolve into solution and will be collected as anode sludge.

- (c) At the cathode, Cu is deposited.

Since  $E(\text{Zn}^{2+}/\text{Zn})$  is less positive than  $E(\text{Cu}^{2+}/\text{Cu})$ , the zinc impurities will not be oxidised and will thus remain in solution.

- (d) amount of Cu to be coated =  $0.50 \div 63.5 = 7.87 \times 10^{-3}$  mol

Since  $2\text{e}^- \equiv 1\text{Cu}$ ,

amount of electrons required =  $2 \times (7.87 \times 10^{-3}) = 0.0157$  mol

Using  $Q = It = n_e F$ ,

$$\text{time taken, } t = \frac{0.0157 \times 96500}{0.20} = 7600 \text{ s}$$

2 (a) (i)

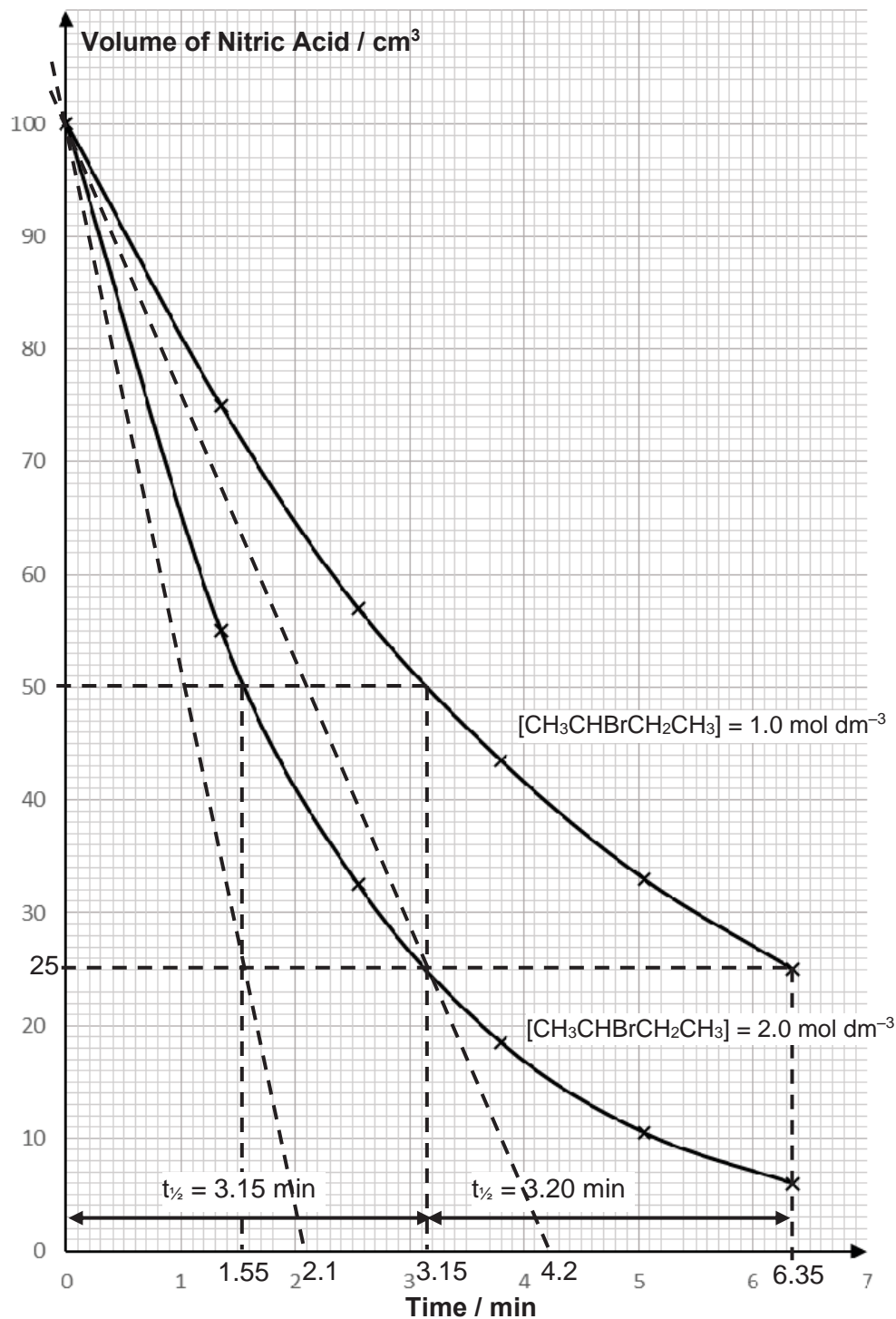

$$\text{average } t_{1/2} = \frac{3.15 + 3.20}{2} = 3.18 \text{ min}$$

Since half-lives are approximately constant, the reaction is first order w.r.t [NaOH(aq)].

2 (a) (i) When  $[\text{CH}_3\text{CHBrCH}_2\text{CH}_3] = 2.0 \text{ mol dm}^{-3}$ ,

$t_{1/2}$  of NaOH = 1.55 min

When  $[\text{CH}_3\text{CHBrCH}_2\text{CH}_3]$  is doubled, half-life of NaOH is (approximately) halved, implying that the rate is (approximately) doubled.

Order of reaction w.r.t  $[\text{CH}_3\text{CHBrCH}_2\text{CH}_3]$  is one.

OR

When  $[\text{CH}_3\text{CHBrCH}_2\text{CH}_3] = 1.0 \text{ mol dm}^{-3}$ ,

$$\text{initial rate} = |\text{tangent at } t = 0| = \left| \frac{100 - 0}{0 - 4.2} \right| = 23.8$$

When  $[\text{CH}_3\text{CHBrCH}_2\text{CH}_3] = 2.0 \text{ mol dm}^{-3}$ ,

$$\text{initial rate} = |\text{tangent at } t = 0| = \left| \frac{100 - 0}{0 - 2.1} \right| = 47.6$$

When  $[\text{CH}_3\text{CHBrCH}_2\text{CH}_3]$  is doubled, initial rate doubles.

Order of reaction w.r.t  $[\text{CH}_3\text{CHBrCH}_2\text{CH}_3]$  is one.

(iii)  $\text{rate} = k[\text{CH}_3\text{CHBrCH}_2\text{CH}_3][\text{OH}^-]$

(iv) Since  $[\text{CH}_3\text{CHBrCH}_2\text{CH}_3]$  is in large excess as compared to  $[\text{NaOH}]$ , it can be assumed that  $[\text{CH}_3\text{CHBrCH}_2\text{CH}_3]$  remains approximately constant throughout.

$$\therefore \text{rate} = k' [\text{NaOH}] \quad \text{where } k' = k[\text{CH}_3\text{CHBrCH}_2\text{CH}_3]$$

$$t_{1/2} \text{ of NaOH} = \frac{\ln 2}{k'} = \frac{\ln 2}{k[\text{CH}_3\text{CHBrCH}_2\text{CH}_3]}$$

$\therefore t_{1/2}$  of NaOH is independent of  $[\text{NaOH}]$  and is 3.18 min.

(v) Using  $\frac{\text{final amount}}{\text{initial amount}} = \left(\frac{1}{2}\right)^n$  where  $n$  is the no. of half-life passed,

$$\frac{1}{100} = \left(\frac{1}{2}\right)^n \Rightarrow n = 6.64$$

$$\text{time taken} = 6.64 \times 3.18 = 21.1 \text{ min}$$

(vi) Type of mechanism: nucleophilic substitution

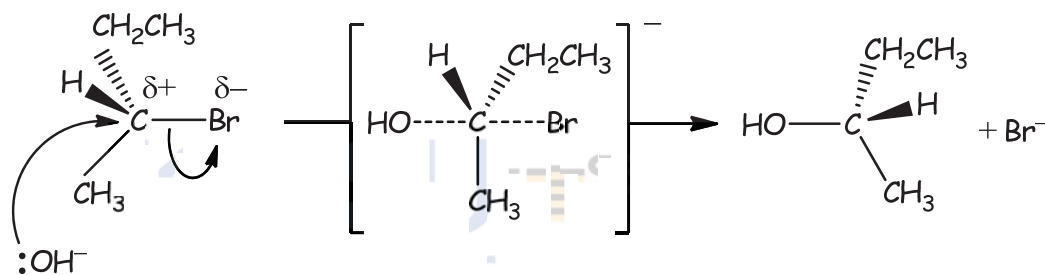

2 (b) (ii) Energy / kJ mol<sup>-1</sup>

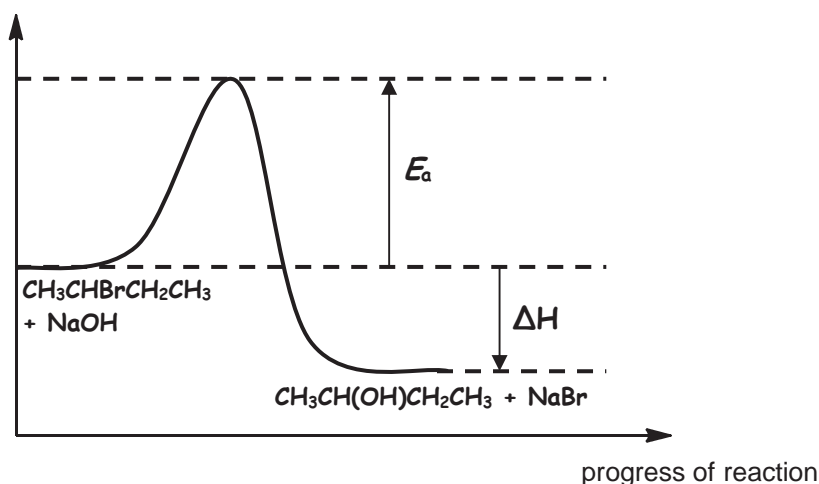

- (iii) The rate of reaction will be slower.  
 Since  $E(\text{C}-\text{Cl})$  is larger than  $E(\text{C}-\text{Br})$ , it implies that  $\text{C}-\text{Cl}$  bond is stronger and harder to break compared  $\text{C}-\text{Br}$  bond.
- (iv) Yes. Since there is an inversion of stereochemical configuration due to the backside attack of the nucleophile, only one of the enantiomers is produced.

3 (a) A: MgO    B: CO<sub>2</sub>    C: Mg(OH)<sub>2</sub>    D: MgSO<sub>4</sub>    E: CaCO<sub>3</sub>

- (b) MgSO<sub>4</sub> dissolves in water to give [Mg(H<sub>2</sub>O)<sub>6</sub>]<sup>2+</sup>, which hydrolyses slightly due to slightly higher charge density of Mg<sup>2+</sup> to give an acidic solution.

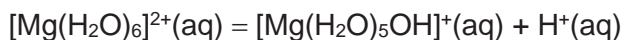

(c) (i) Volume of gas B

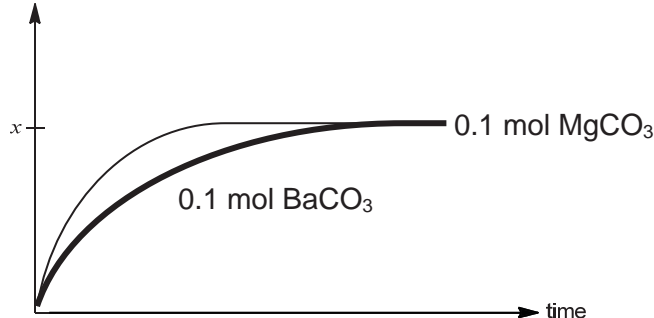

- (ii) Since  $1 \text{ CO}_2 \equiv 1 \text{ MCO}_3$  and amount of BaCO<sub>3</sub> used is the same, the total volume of gas B formed is the same.  
 Compared to Mg<sup>2+</sup>, Ba<sup>2+</sup> has a larger radius and smaller charge density.  
 Hence, Ba<sup>2+</sup> is less able to polarise large CO<sub>3</sub><sup>2-</sup> anion and BaCO<sub>3</sub> is more thermally stable and decomposes less readily, resulting in a longer heating time.

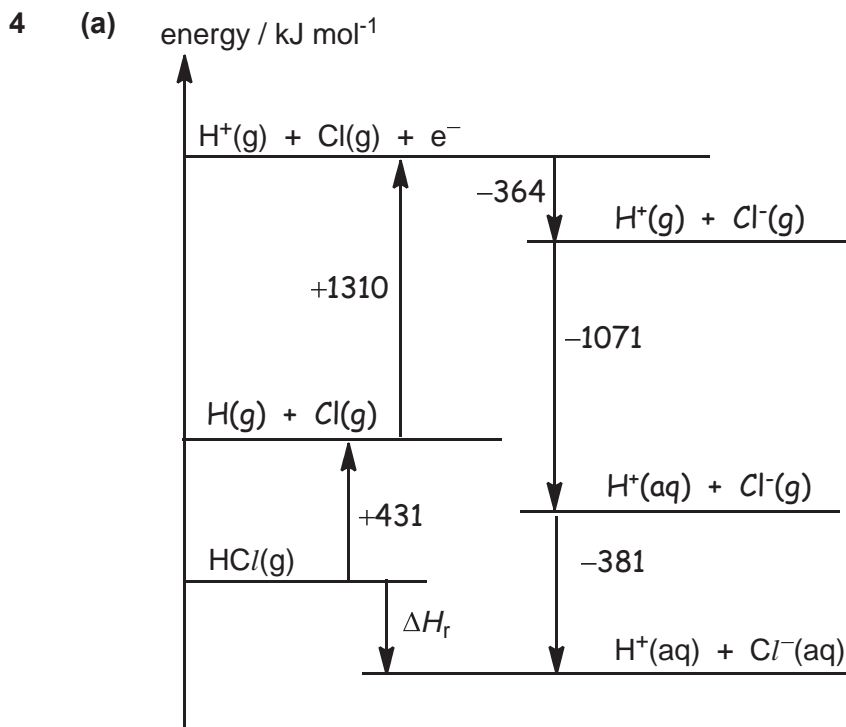

By Hess's Law,

$$\Delta H_r = (+431) + (+1310) + (-364) + (-1071) + (-381) = -75.0 \text{ kJ mol}^{-1}$$

(b)  $\Delta G_{\text{soln}} = -75 - (-18) = -57.0 \text{ kJ mol}^{-1}$

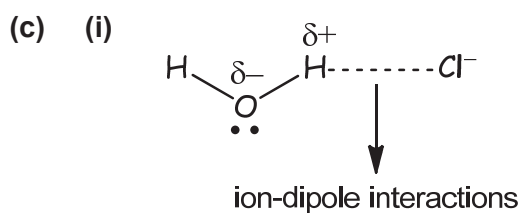

(ii) Compared to Cl<sup>-</sup>, Br<sup>-</sup> has larger radius and lower charge density, resulting in a weaker ion-dipole interactions formed between Br<sup>-</sup> and H<sub>2</sub>O molecule.  
∴ Br<sup>-</sup> has a smaller magnitude of ΔH<sub>hyd</sub>.

(e) Test : Add Cl<sub>2</sub>(aq) to both samples separately.  
Observation : For HBr(aq), colourless solution turns orange, due to Br<sub>2</sub>(aq).  
For HCl(aq), colourless solution remains.

5 (a) NaOH(aq) (or KOH(aq) or H<sub>2</sub>SO<sub>4</sub>(aq) or HCl(aq)), heat for prolonged period.

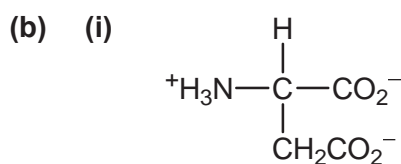

(ii) anode



5 (c) (i)

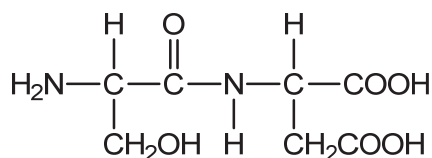

(ii) ser-asp-tyr-val-gly-ser

reagent & condition	Aqueous Br <sub>2</sub>	Cold aqueous NaOH	CH <sub>3</sub> COOH
product	$\begin{array}{c} \text{H} \\   \\ \text{H}_2\text{N}-\text{C}-\text{COOH} \\   \\ \text{CH}_2 \\   \\ \text{C}_6\text{H}_3(\text{Br})_2\text{OH} \end{array}$	$\begin{array}{c} \text{H} \\   \\ \text{H}_2\text{N}-\text{C}-\text{COO}^-\text{Na}^+ \\   \\ \text{CH}_2 \\   \\ \text{C}_6\text{H}_4\text{O}^-\text{Na}^+ \end{array}$	$\begin{array}{c} \text{H} \\   \\ \text{H}_3\text{N}^+-\text{C}-\text{COOH} \\   \\ \text{CH}_2 \\   \\ \text{C}_6\text{H}_4\text{OH} \\ \text{CH}_3\text{COO}^- \end{array}$

6 (a) (i) amount of HCl used =  $0.10 \times \frac{30.0}{1000} = 3.00 \times 10^{-3}$  mol

Since 1 HCl  $\equiv$  1 NaOH,

amount of NaOH left unreacted =  $3.00 \times 10^{-3}$  mol

total amount of NaOH added initially =  $0.10 \times \frac{50.0}{1000} = 5.00 \times 10^{-3}$  mol

amount of NaOH reacted with Br<sub>2</sub> =  $(5.00 \times 10^{-3}) - (3.00 \times 10^{-3})$   
=  $2.00 \times 10^{-3}$  mol

amount of Br<sub>2</sub> used =  $0.10 \times \frac{10.0}{1000} = 1.00 \times 10^{-3}$  mol

$\therefore$  Mole ratio of Br<sub>2</sub> : NaOH =  $1.00 \times 10^{-3} : 2.00 \times 10^{-3} = 1 : 2$

(ii) Br<sub>2</sub> + 2OH<sup>-</sup> → Br<sup>-</sup> + BrO<sup>-</sup> + H<sub>2</sub>O  
value of x: 1

(b) (i) CH<sub>2</sub>BrCHBrCH<sub>3</sub>

(ii) <sup>79</sup>Br and <sup>81</sup>Br in the ratio of 1 : 1

(iii) type of mechanism: electrophilic addition

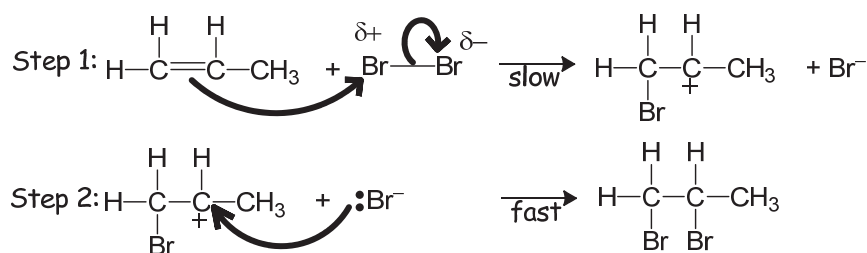

- 6 (c) (i) Since the O atom of  $\text{H}_2\text{O}$  also possesses a lone pair of electrons, the O atom of  $\text{H}_2\text{O}$  can act as a nucleophile to attack the electron-deficient  $\text{C}^+$  of carbocation, forming the halohydrin.

Since water is present in large excess compared to  $\text{Br}_2$ , there will be relatively much more  $\text{H}_2\text{O}$  molecule to act as the nucleophile than the  $\text{Br}^-$  present in the mixture.

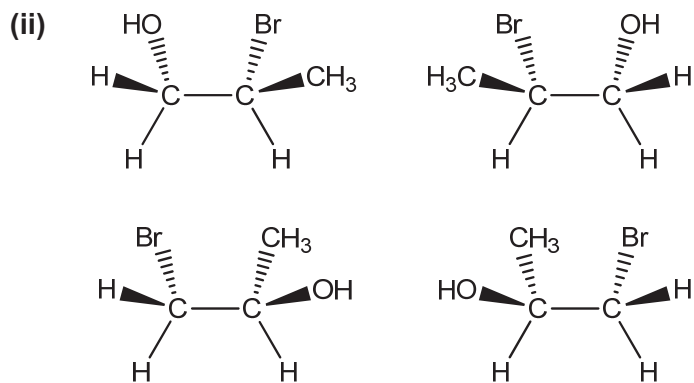

**Suggested Answers for 2017 H2 Chemistry (9729) Prelim Paper 3**

- 1 (a) (i) Group 2 elements have giant metallic structures with strong electrostatic attraction between a lattice of positive ions and delocalised electrons.

Since  $\text{Ca}^{2+}$  has a smaller radius and thus greater charge density than  $\text{Ba}^{2+}$ , more energy is required to overcome the stronger metallic bonds in Ca than that in Ba. Hence Ca has a higher melting point than Ba.

- (ii) Solution turns from purple to blue OR effervescence is observed with calcium and barium. White precipitate is observed with calcium only.



Ca has a larger nuclear charge and smaller radius than K while shielding effect by inner shell electrons is relatively similar. Thus the nuclear attraction on the outermost electron is stronger in Ca as compared to that in K. Hence the first ionisation energy of calcium is higher than that of potassium.

The 4s electron to be removed from Ca is nearer to the nucleus and has lower energy than the 4p electron to be removed from Ga. Hence the first ionisation energy of calcium is higher than that of gallium.

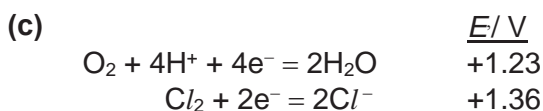

For *dilute*  $\text{BaCl}_2(\text{aq})$ ,

$\text{H}_2\text{O}$  is more easily oxidised than  $\text{Cl}^-$  since  $E(\text{O}_2/\text{H}_2\text{O})$  is less positive than  $E(\text{Cl}_2/\text{Cl}^-)$ . Hence,  $\text{O}_2$  gas is produced at the anode.

For *concentrated*  $\text{BaCl}_2(\text{aq})$ ,

Higher  $[\text{Cl}^-]$  causes the position of equilibrium of  $\text{Cl}_2 + 2\text{e}^- = 2\text{Cl}^-$  to shift left, making  $E(\text{Cl}_2/\text{Cl}^-)$  less positive than  $E(\text{O}_2/\text{H}_2\text{O})$ . Thus,  $\text{Cl}^-$  becomes more easily oxidised than  $\text{H}_2\text{O}$  and hence,  $\text{Cl}_2$  gas is produced at the anode.

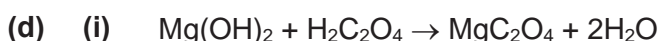

**A**

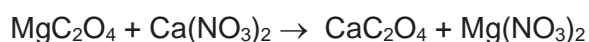

**B**

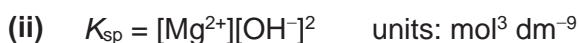

$$2.00 \times 10^{-11} = (x)(2x)^2 = 4x^3$$

$$[\text{Mg}(\text{OH})_2(\text{aq})] = x = 1.71 \times 10^{-4} \text{ mol dm}^{-3}$$

$$[\text{OH}^-] = 2x = 2 \times 1.71 \times 10^{-4} = 3.42 \times 10^{-4} \text{ mol dm}^{-3}$$

$$\text{pH} = 14 - (-\lg 3.42 \times 10^{-4}) = 10.5$$

(e)

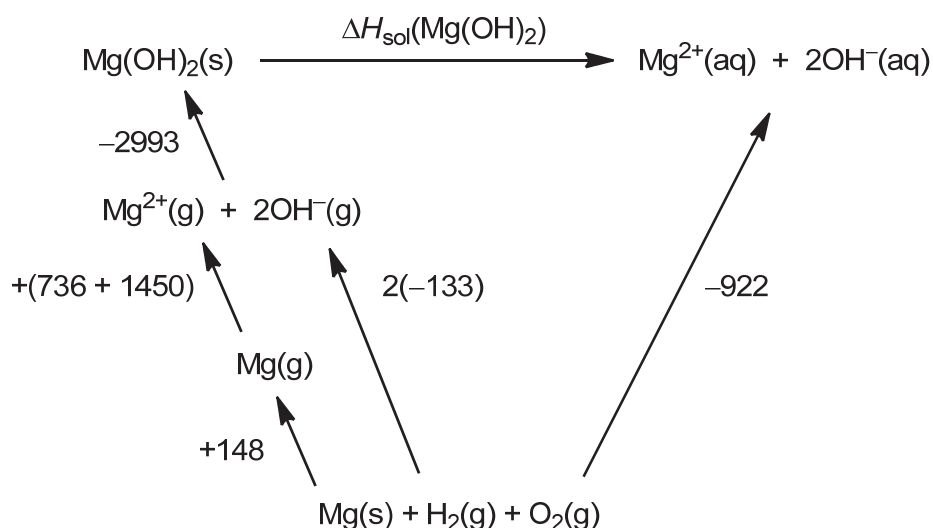

By Hess' Law,

$$\begin{aligned}
 \Delta H_{\text{sol}}(\text{Mg(OH)}_2(\text{s})) &= -(-2993) - (736+1450) - (148) - 2(-133) + (-922) \\
 &= +3 \text{ kJ mol}^{-1}
 \end{aligned}$$

2 (a) Reactivity decreases down the group.

$$E(\text{Cl}-\text{Cl}) = +244 \text{ kJ mol}^{-1}, \quad E(\text{Br}-\text{Br}) = +193 \text{ kJ mol}^{-1}; \quad E(\text{I}-\text{I}) = +151 \text{ kJ mol}^{-1}$$

$$E(\text{H}-\text{Cl}) = +431 \text{ kJ mol}^{-1}, \quad E(\text{H}-\text{Br}) = +366 \text{ kJ mol}^{-1}; \quad E(\text{H}-\text{I}) = +299 \text{ kJ mol}^{-1}$$

This is because the decrease in  $E(\text{H}-\text{X})$  is more significant than the decrease in  $E(\text{X}-\text{X})$  down the group.

(b) (i)  $\text{BaSO}_4$

(ii)  $\text{Br}_2$  causes a larger increase in the oxidation state of S from +2 in  $\text{S}_2\text{O}_3^{2-}$  to +6 in  $\text{SO}_4^{2-}$ , as compared to  $\text{I}_2$  which causes a smaller increase in the oxidation state of S from +2 in  $\text{S}_2\text{O}_3^{2-}$  to +2.5 in  $\text{S}_4\text{O}_6^{2-}$ .

Therefore,  $\text{Br}_2$  is a stronger oxidising agent than  $\text{I}_2$ .

(c) When  $\text{NH}_3(\text{aq})$  is added,  $[\text{Ag}(\text{NH}_3)_2]^+$  complex ion is formed.

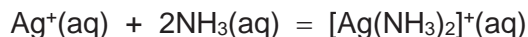

Due to the formation of this complex ion,  $[\text{Ag}^+]$  in the solution decreases and causes the position of equilibrium of  $\text{AgX}(\text{s}) = \text{Ag}^+(\text{aq}) + \text{X}^-(\text{aq})$  to shift to the right, increasing the solubility of both  $\text{AgX}$ .

However,  $\text{AgCl}$  has a higher  $K_{\text{sp}}$  than  $\text{AgI}$  so  $\text{AgCl}$  dissolves completely but  $\text{AgI}$  hardly dissolves in  $\text{NH}_3(\text{aq})$ .

(d) (i) Name of mechanism: free radical substitution

Initiation step



Propagation steps

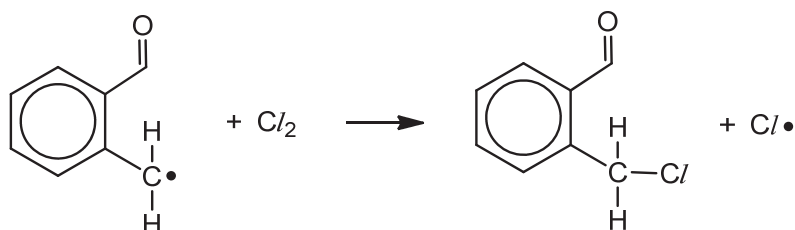
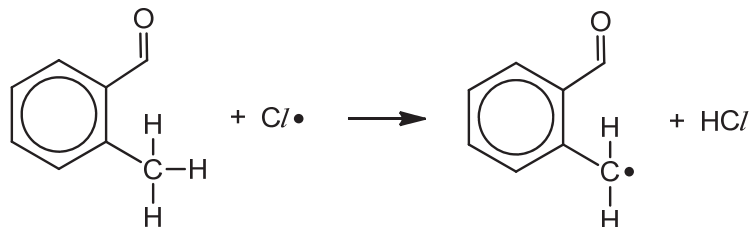

Termination steps

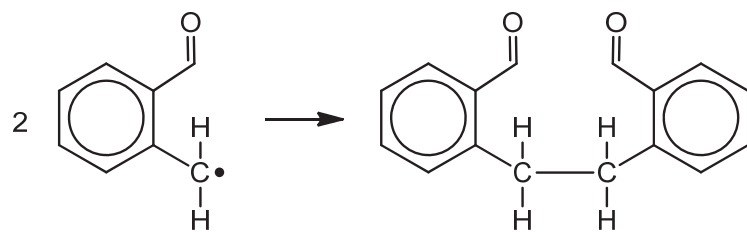
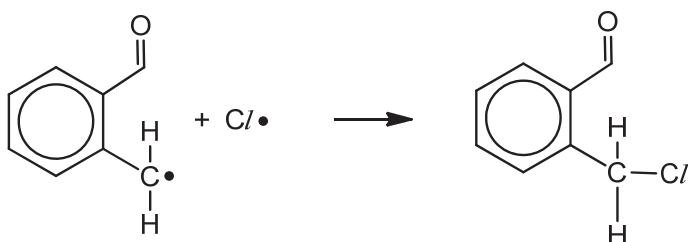

any 2 equations

(ii) II: HCN, trace amount of NaCN or NaOH

III: LiAlH<sub>4</sub>, dry ether

IV: ethanol, heat in sealed tube

(iii)

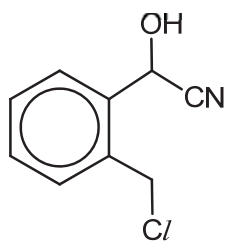

D

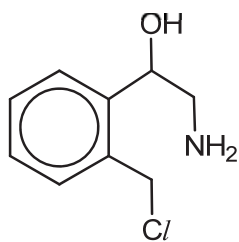

E

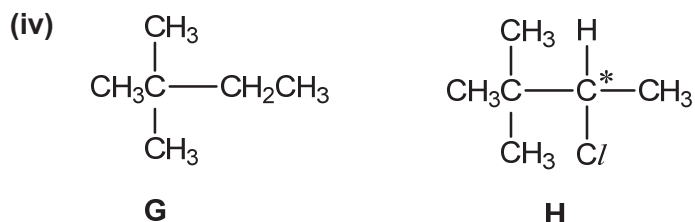

**H** has a chiral C and thus exhibits enantiomerism.

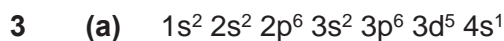

(b) (i) Lower energy level:

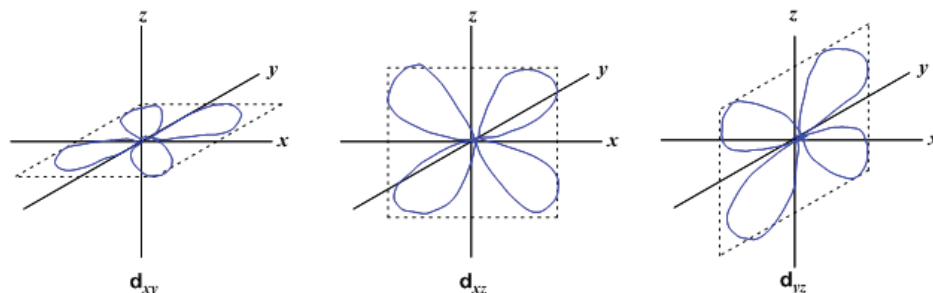

Upper energy level:

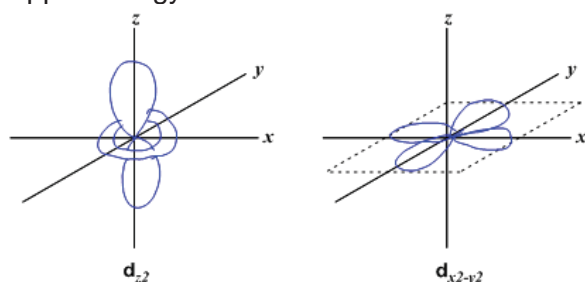

(ii) Chromium complexes are coloured due to the electron transition between  $d$ -orbitals.

The presence of ligands causes the  $d$  orbitals to split into 2 different energy levels.

The energy gap is relatively small such that radiation from the visible light is absorbed when an electron transits from a lower energy  $d$ -orbital to higher energy  $d$ -orbital which is partially filled.

Hence, the colour seen is the complement of the colours absorbed.

(c) (i) In alkaline medium,  $\text{OH}^-$  reacts with  $\text{H}^+$  which reduces  $[\text{H}^+]$ . This causes the position of equilibrium of  $\text{Cr}_2\text{O}_7^{2-} + \text{H}_2\text{O} = 2\text{CrO}_4^{2-} + 2\text{H}^+$  to shift right. Hence, there will be more  $\text{CrO}_4^{2-}$  in the mixture than  $\text{Cr}_2\text{O}_7^{2-}$ .

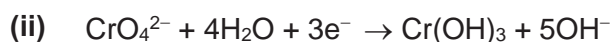

(iii)	mole ratio of	Cr(OH) <sub>3</sub>	:	e <sup>-</sup>	:	reducing agent
		0.200	:	3(0.200)	:	
			:	3(0.200)	:	0.300
		2	:	6	:	3

Using  $\Delta G^\circ = -n_e F E_{\text{cell}}$  and  $n_e = 6$ ,

$$-365 \times 1000 = -6 \times 96500 \times E_{\text{cell}}$$

$$E_{\text{cell}} = +0.63 \text{ V} = E(\text{CrO}_4^{2-}/\text{Cr(OH)}_3) - (-0.76)$$

$$E(\text{CrO}_4^{2-}/\text{Cr(OH)}_3) = -0.13 \text{ V}$$

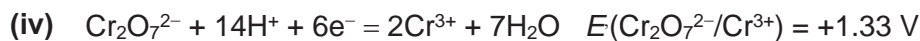

Since  $E(\text{CrO}_4^{2-}/\text{X})$  is less positive than  $E(\text{Cr}_2\text{O}_7^{2-}/\text{Cr}^{3+})$ , it implies that  $\text{CrO}_4^{2-}$  is less readily reduced and thus  $\text{CrO}_4^{2-}$  is a weaker oxidising agent than  $\text{Cr}_2\text{O}_7^{2-}$ .

- (d) (i) reaction 1 : cold alkaline  $\text{KMnO}_4(\text{aq})$   
 reaction 2 : acidified  $\text{K}_2\text{Cr}_2\text{O}_7(\text{aq})$ , heat with immediate distillation  
 reaction 3 : acidified  $\text{K}_2\text{Cr}_2\text{O}_7(\text{aq})$ , heat under reflux  
 reaction 4 : acidified  $\text{KMnO}_4(\text{aq})$ , heat under reflux

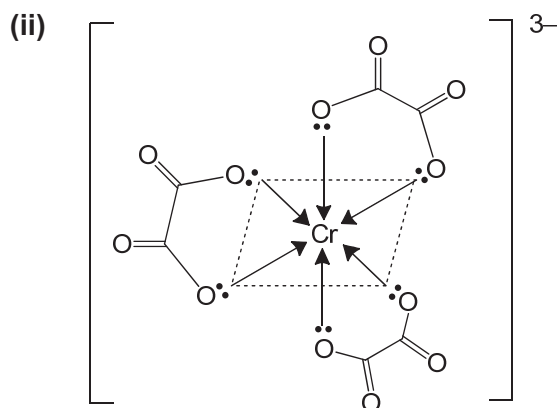

- (e) Heterogeneous catalysis.

When the reactant molecules adsorb on the catalyst surface, the bonds in the molecules are weakened, lowering the activation energy. The surface concentrations of the reactants are increased as well. The product formed then desorbs from the catalyst surface.

- 4 (a) (i) acid–base reaction
- (ii) p–p orbital overlap results in the delocalisation of lone pair on  $\alpha\text{-C}^-$  into the adjacent  $\text{C}=\text{O}$ , dispersing the negative charge and thus making  $\alpha\text{-anion}$  more stable than  $\beta\text{-anion}$ . Hence,  $\alpha\text{-anion}$  is preferentially formed.
- (iii) nucleophile

(iv)

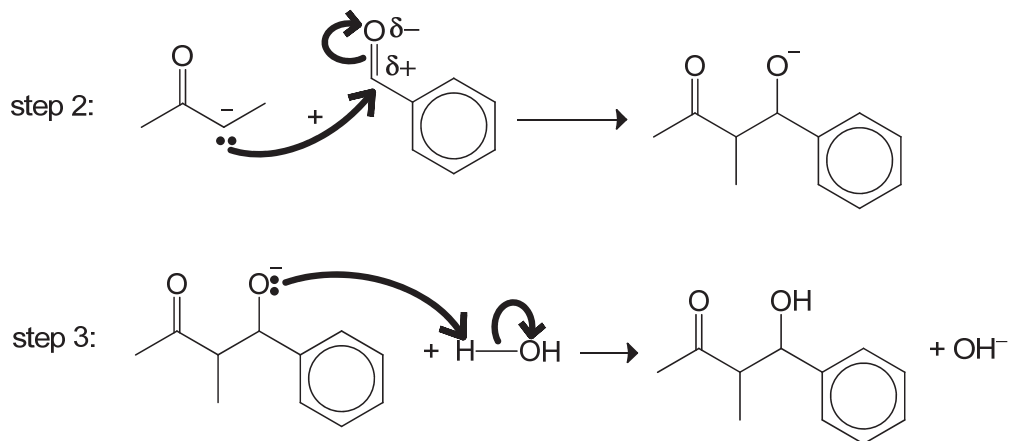

(b) (i)

bonds broken		bonds formed	
1 C=O	+740	1 C=C	+610
2 C-H	2(+410)	2 O-H	2(+460)
Total	+1560	Total	+1530

$$\Delta H_r = +1560 - (+1530) = +30 \text{ kJ mol}^{-1}$$

(ii) Bond energies quoted from *Data Booklet* are average values derived from a full range of molecules that contain the particular bonds.

The bond energies quoted are for gaseous molecules but the reactants and products are in liquid state and hence, the enthalpy changes of vapourisation are not accounted for.

(iii) 
$$\Delta G^{\ddagger} = \underbrace{\Delta H^{\ddagger}}_{+ve} - T \underbrace{\Delta S^{\ddagger}}_{\substack{+ve \\ -ve}}$$

When temperature increases,  $-T\Delta S$  becomes more negative.

So at high enough temperature,  $\Delta G < 0$  when  $|\Delta H| < |-T\Delta S|$ .

Hence, the Aldol Condensation is favoured by a high temperature.

(iv) Test: Add aqueous  $\text{Br}_2$  to a small sample of the mixture.

Observation: If **P** is formed, orange  $\text{Br}_2(\text{aq})$  will decolourise.

(c) (i) According to Lewis theory, an acid is an electron pair acceptor while a base is an electron pair donor.

(ii) Electron-donating  $-\text{CH}_2\text{CH}_3$  makes the lone pair on  $\text{O}^-$  more available for protonation, making  $\text{CH}_3\text{CH}_2\text{O}^-$  a stronger base than  $\text{OH}^-$ .

Hence,  $\text{CH}_3\text{CH}_2\text{O}^-$  favour Aldol Condensation reaction.

(d) (i)  $120^\circ$

(ii) The cyclisation of the above dicarbonyl compound would form a 4-membered ring and the bond angle of  $90^\circ$  is formed, resulting in angle strain in the ring and thus making the compound unstable.

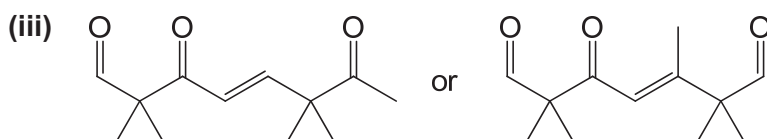



5 (a) (i)



Since C in CO is less electronegative than O in O<sub>2</sub>, the lone pair on C in CO is more available for dative bond formation than O in O<sub>2</sub>.

Hence, CO is a stronger ligand than O<sub>2</sub> and thus the formation of carboxyhaemoglobin occurs much more readily.

(ii) During oxygen therapy, [O<sub>2</sub>] is high and this causes the position of equilibrium 1 to shift right which reduces [Hb].

The reduction of [Hb] causes the position of equilibrium 2 to shift left which reduces [Hb(CO)<sub>4</sub>].

Hence, the proportion of [Hb(O<sub>2</sub>)<sub>4</sub>] in the blood is increased while the proportion of Hb(CO)<sub>4</sub> in the blood is reduced, allowing more O<sub>2</sub> to be transported to other parts of the body.

(b) (i) Any two of the following:

- Volume of gas molecules is negligible as compared to that of the gas.
- There are no intermolecular forces between the molecules.
- Collisions between molecules are perfectly elastic.
- Molecules move in constant, random motion.
- Kinetic energy of the molecules is directly proportional to the temperature.

(ii) Since the molar ratio of CO : H<sub>2</sub>O is 1:1, CO is the limiting reagent.

$$\text{Equilibrium amount of H}_2 = (2.0 \times 10^{-4}) \times \frac{97}{100} = 1.94 \times 10^{-4} \text{ mol}$$

Using ideal gas equation (*i.e.*  $pV = nRT$ ),

$$\begin{aligned} \text{equilibrium partial pressure of H}_2 &= \frac{(1.94 \times 10^{-4}) \times 8.31 \times 600}{500 \times 10^{-6}} \\ &= 1930 \text{ Pa} \end{aligned}$$

(iii) It is valid as H<sub>2</sub> tends towards ideal gas behaviour since the H<sub>2</sub> molecule is small (or volume of the container is large due to low pressure) so the volume of the molecules is negligible as compared to that of the gas.

OR

It is valid as H<sub>2</sub> tends towards ideal gas behaviour since the H<sub>2</sub> molecule has few electrons (or volume of the container is large due to low pressure and thus molecules are far apart or the molecules have high kinetic energies to overcome intermolecular forces due to high temperature) so the intermolecular forces in H<sub>2</sub> is negligible.

(iv)  $K_p = \frac{p_{\text{CO}_2} \times p_{\text{H}_2}}{p_{\text{CO}} \times p_{\text{H}_2\text{O}}}$     Units of  $K_p$ : no units

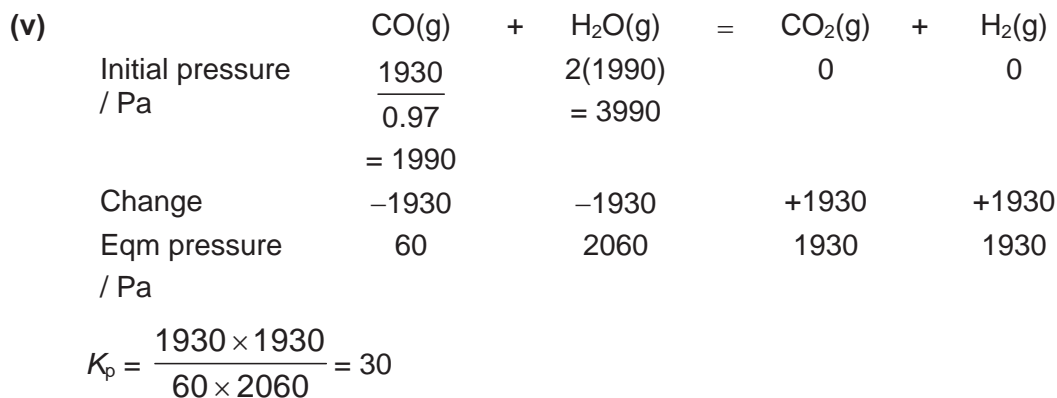

**(c) (i)**  $\Delta S$  is negative because there is a decrease in disorder of the system as the reaction proceeds with a decrease in amount of gaseous particles from 2 mol to 1 mol.

**(ii)** enthalpy driven

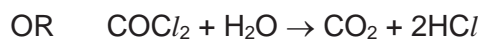
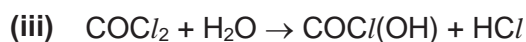

Observation	type of reaction	deduction
<b>W</b> is aromatic.	–	<b>W</b> contains benzene ring.
<b>W</b> (C <sub>12</sub> H <sub>6</sub> O <sub>12</sub> ) + Na <sub>2</sub> CO <sub>3</sub> (aq) → CO <sub>2</sub> (g)	acid-carbonate reaction	<b>W</b> is a carboxylic acid (or has –COOH).
1 mole of <b>W</b> gives 72 dm <sup>3</sup> CO <sub>2</sub> gas	–	$2\text{RCOOH} + \text{Na}_2\text{CO}_3 \rightarrow 2\text{RCOONa} + \text{CO}_2 + \text{H}_2\text{O}$ amount of CO <sub>2</sub> = $\frac{72}{24} = 3 \text{ mol}$ Since 2RCOOH ≡ 1CO <sub>2</sub> , ∴ <b>W</b> has 6 –COOH.
<b>W</b> + appropriate reagent → sweet smelling <b>X</b> (C <sub>12</sub> O <sub>9</sub> )	condensation	Recognise that 6 H and 3 O ( <i>i.e.</i> 3H <sub>2</sub> O) were lost when <b>W</b> is converted into <b>X</b> . <b>X</b> is a cyclic ester.

Combining the deductions, the structure of

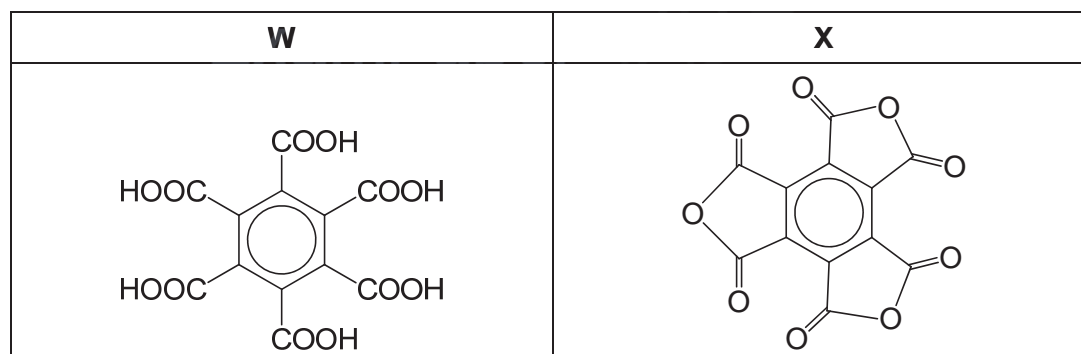

**Suggested Mark Scheme for 2017 JJC Prelim Paper 4 (9729/04)**

1 (a) (i)

Titration number	1	2
final burette reading / cm <sup>3</sup>	23.20	33.25
initial burette reading / cm <sup>3</sup>	0.00	10.00
volume of FA2 (or KMnO <sub>4</sub> ) used / cm <sup>3</sup>	23.20	23.25

✓ ✓

(ii) average volume of **FA2** (or KMnO<sub>4</sub>) used =  $\frac{23.20 + 23.25}{2} = 23.23 \text{ cm}^3$

(b) (i) mass of KMnO<sub>4</sub> in 23.23 cm<sup>3</sup> =  $2.00 \times \frac{23.23}{1000} = 0.0465 \text{ g}$

amount of KMnO<sub>4</sub> used =  $\frac{0.0465}{39.1 + 54.9 + 4(16.0)} = 2.93 \times 10^{-4} \text{ mol}$

(ii) Since  $5\text{FeSO}_4 \equiv 1\text{KMnO}_4$ ,  
amount of FeSO<sub>4</sub> in 25.0 cm<sup>3</sup> of **FA 4** =  $5 \times (2.93 \times 10^{-4}) = 1.47 \times 10^{-3} \text{ mol}$

[FeSO<sub>4</sub>] in **FA 4** =  $(1.47 \times 10^{-3}) \div \frac{25.0}{1000} = 0.0588 \text{ mol dm}^{-3}$

(iii) amount of FeSO<sub>4</sub> in 25.0 cm<sup>3</sup> of **FA 1** = amount of FeSO<sub>4</sub> in 250 cm<sup>3</sup> of **FA 4**  
 $= 0.0588 \times \frac{250}{1000} = 0.0147 \text{ mol}$

[FeSO<sub>4</sub>] in **FA 1** =  $0.0147 \div \frac{25.0}{1000} = 0.588 \text{ mol dm}^{-3}$

or

Using  $c_1V_1 = c_2V_2$ ,

[FeSO<sub>4</sub>] in **FA 1** =  $0.0588 \times \frac{250}{25.0} = 0.588 \text{ mol dm}^{-3}$

(iv) [FeSO<sub>4</sub>] in **FA 1** in g dm<sup>-3</sup> =  $0.588 \times [55.8 + 32.1 + 4(16.0)] = 89.3 \text{ g dm}^{-3}$

% by mass of FeSO<sub>4</sub> in **FA 1** =  $\frac{89.3}{215.0} \times 100 \% = 41.5 \%$

% error =  $\frac{\text{error per reading} \times \text{no. of reading}}{\text{quantity measured}} \times 100 \%$

(c) (i) % error =  $\frac{0.06 \times 1}{25.0} \times 100 \% = 0.240 \%$

(ii) % error =  $\frac{0.05 \times 2}{23.23} \times 100 \% = 0.430 \%$

2 (a)

Experiment	volume of FA 5 / cm <sup>3</sup>	volume of FA 3 / cm <sup>3</sup>	volume of water / cm <sup>3</sup>	t / s	log (1/t)	log (volume of FA 5)
1	50.0	5.0	0.0	18	-1.26	1.70
2	10.0	5.0	40.0	93	-1.96	1.00
3	20.0	5.0	30.0	45	-1.65	1.30
4	30.0	5.0	20.0	30	-1.48	1.48
5	40.0	5.0	10.0	23	-1.36	1.60

(b)

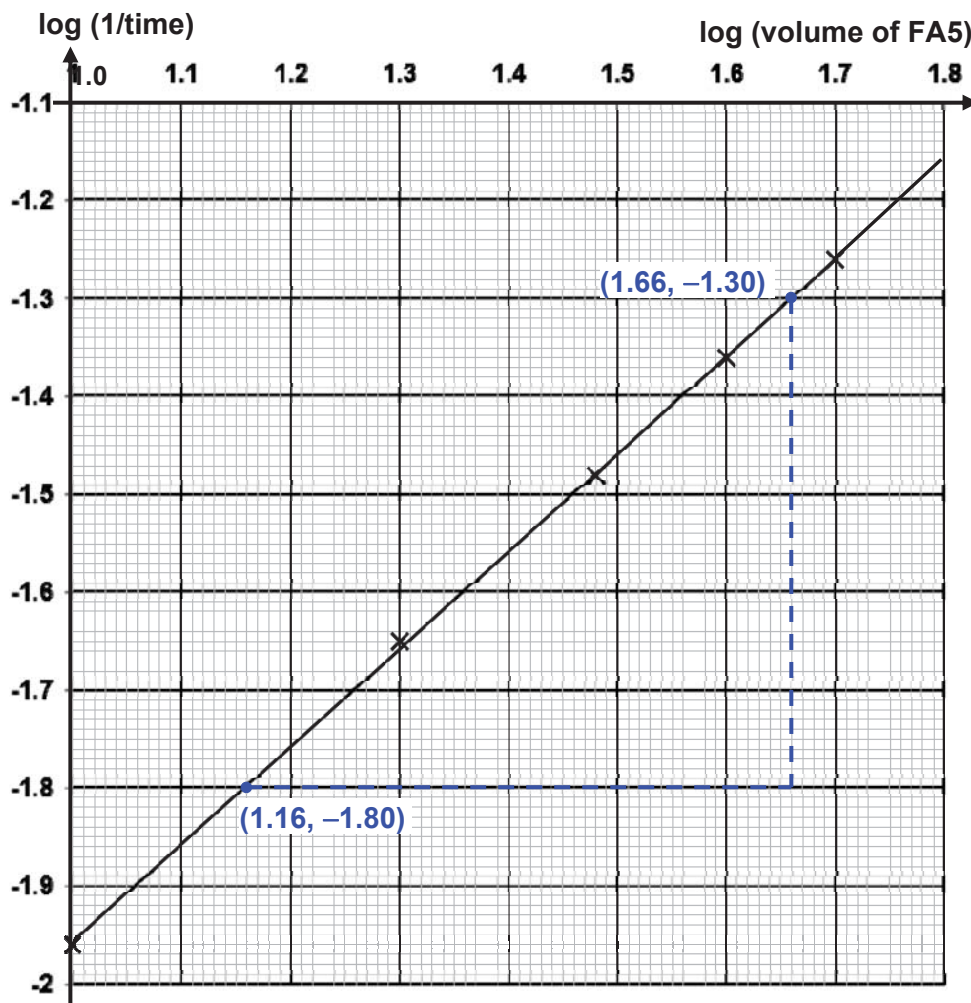

(c) 
$$\text{gradient} = \frac{(-1.80) - (-1.30)}{1.16 - 1.66} = 1.00 = 1$$

The reaction is **first** order with respect to thiosulfate ions, S<sub>2</sub>O<sub>3</sub><sup>2-</sup>.

(d)

Experiment	Volume of FA 5 / cm <sup>3</sup>	Volume of deionised water / cm <sup>3</sup>	Volume of FA 3 / cm <sup>3</sup>
2	10.0	40.0	5.0
(i)	10.0	35.0	10.0
(ii)	10.0	25.0	20.0

2 (e) (i) Since  $2\text{H}^+ \equiv 1\text{H}_2\text{SO}_4$  while  $1\text{H}^+ \equiv 1\text{HCl}$ ,  $[\text{H}^+]$  is halved. Since the reaction is first order w.r.t  $[\text{H}^+]$ , when  $[\text{H}^+]$  is halved, the rate is halved and hence, the reaction time will be doubled.

(ii) Since the total volume of mixture is kept constant (*i.e.*  $55\text{ cm}^3$ ), the depth of the mixture in a  $100\text{ cm}^3$  beaker is greater and hence, the reaction time will be shorter.

3 (a) (i) On strong heating, pale green solid turns yellow (or brown) and becomes black eventually. Condensation (or steamy fumes) on test-tube.  
 Colourless, pungent gas turns damp red litmus blue.  
 Colourless, pungent gas turns damp blue litmus red.  
 Colourless, pungent gas decolourised purple  $\text{KMnO}_4$ .

3 (a) (ii)

test	observations	
	FA 6	FA 7
1. To a 0.5 cm depth of solution in a boiling tube add aqueous sodium hydroxide, then	Green ppt insoluble in excess $\text{NaOH}(\text{aq})$ , turning brown on contact with air.	No ppt formed
Warm gently.	Colourless, pungent gas turns damp red litmus paper blue.	No gas evolved.
Allow to cool, add a piece of aluminium foil and warm again.		Effervescence observed. Colourless, pungent gas turns damp red litmus paper blue.
2. To a 1 cm depth of solution in at test-tube add a 1 cm depth of dilute sulfuric acid followed by a few drops of aqueous potassium manganate(VII).	Purple $\text{KMnO}_4$ decolourised.	Effervescence observed. Brown, pungent gas formed. Purple $\text{KMnO}_4$ decolourised.
3. To a 1 cm depth of solution in at test-tube add a 2 cm depth of hydrogen peroxide and leave to stand.	Effervescence observed. Colourless, odourless gas relights glowing splint. Solution turns yellow.	No gas evolved.
4. To a 1 cm depth of solution in at test-tube add a 1 cm depth of dilute hydrochloric acid, then	No gas evolved.	Effervescence observed. Brown, pungent gas formed.
Add a 1 cm depth of aqueous barium nitrate.	White ppt formed.	No ppt formed.

(b) (i)		cation(s)	anion(s)
	<b>FA 6</b>	$\text{Fe}^{2+}$ , $\text{NH}_4^+$	$\text{SO}_4^{2-}$
	<b>FA 7</b>	unknown	$\text{NO}_2^-$

- 3 (b) (ii) To 1 cm depth of the **FA 6** in a test-tube, add 1 cm depth of  $\text{NH}_3(\text{aq})$ .  
Green ppt insoluble in excess  $\text{NH}_3(\text{aq})$ , turning brown on contact with air.

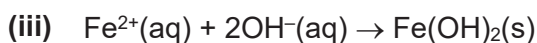

or



Test	Observation
To 1 cm depth of the 4 samples in separate test-tubes, add 1 cm depth of Tollens' reagent. Warm the mixture in hot water-bath.	For benzaldehyde, silver mirror is formed but not for the other 3 samples.
To 1 cm depth of the remaining 3 samples in separate test-tubes, add a few drops of acidified $\text{KMnO}_4(\text{aq})$ (or acidified $\text{K}_2\text{Cr}_2\text{O}_7(\text{aq})$ ). Warm the mixture in hot water-bath.	For propan-2-ol, purple $\text{KMnO}_4$ decolourises (or orange $\text{K}_2\text{Cr}_2\text{O}_7$ turns green) but not for the other 2 samples.
To 1 cm depth of the remaining 2 samples in separate test-tubes, add 1 cm depth of alkaline $\text{I}_2(\text{aq})$ . Warm the mixture in hot water-bath.	For propanone, pale yellow ppt of $\text{CHI}_3$ is formed but not for the other sample.
To 1 cm depth of the last sample in a test-tube, add 1 small spatula of $\text{PCl}_5(\text{s})$ .	For 2-methylpropan-2-ol, white fumes of $\text{HCl}$ observed.

\*The last two steps can be swapped.

- 4 (a) Downward displacement gas collection method:

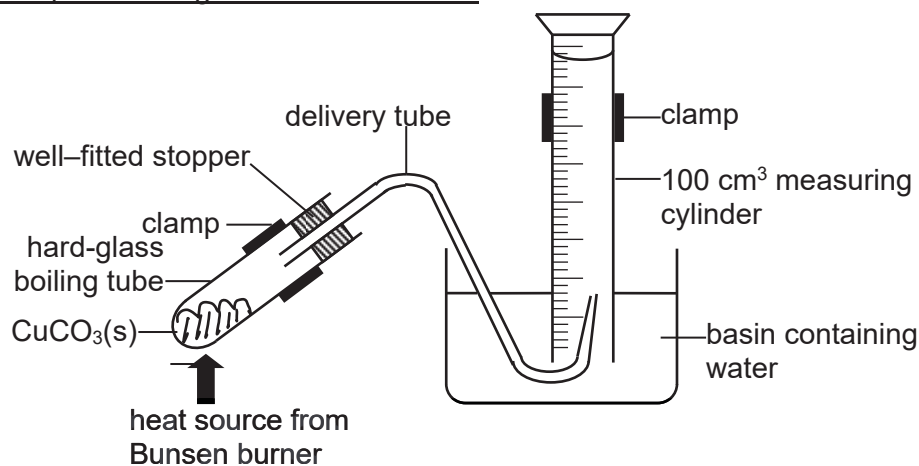

Gas syringe method:

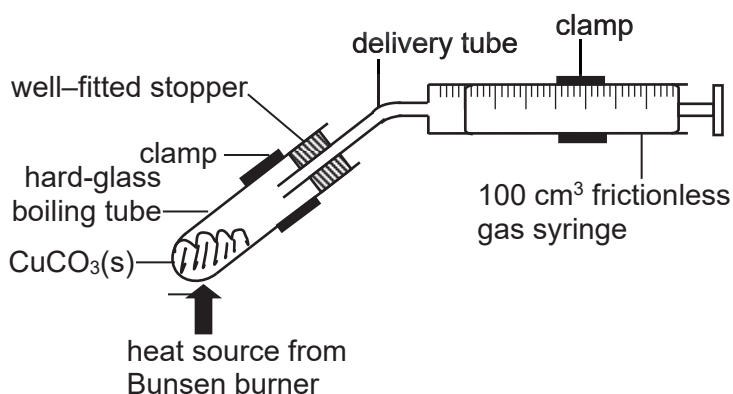

(b) If a 100 cm<sup>3</sup> capacity apparatus is used,

$$\text{maximum amount of gas evolved} = \frac{100}{1000} \div 25.3 = 3.95 \times 10^{-3} \text{ mol}$$

For Equation 4.1, since  $2\text{CuCO}_3 \equiv 2.5 \text{ gas (CO}_2 + \text{O}_2)$ ,

$$\text{amount of CuCO}_3 \text{ required} = \frac{2}{2.5} \times (3.95 \times 10^{-3}) = 3.16 \times 10^{-3} \text{ mol}$$

$$\text{mass of CuCO}_3 \text{ required} = (3.16 \times 10^{-3}) \times 123.5 = 0.391 \text{ g}$$

For Equation 4.2, since  $1\text{CuCO}_3 \equiv 1 \text{ CO}_2$ ,

$$\text{mass of CuCO}_3 \text{ required} = (3.95 \times 10^{-3}) \times 123.5 = 0.488 \text{ g}$$

#### Experimental Procedures:

step 1: Using an electronic weighing balance precise to 3 decimal places, weigh a clean and dry boiling tube and record its mass as  $m_1$ .

step 2: Weigh accurately 0.391 g of  $\text{CuCO}_3$  into the boiling tube and record the total mass as  $m_2$ .

$$\therefore \text{mass of CuCO}_3 \text{ used} = (m_2 - m_1) \text{ g}$$

step 3: Set up the apparatus as shown in part (a).

step 4: Recording the initial syringe (or burette or measuring cylinder) reading as  $V_1$ .

step 5: Light up the Bunsen burner and heat the tube with its content gently then strongly. Decomposition is complete when the syringe piston stops moving (or water level in measuring cylinder/burette stops falling).

step 6: Recording the final syringe (or burette or measuring cylinder) reading as  $V_2$ .

$$\therefore \text{volume of gas collected} = (V_2 - V_1) \text{ cm}^3$$

$$\text{amount of CuCO}_3 \text{ used} = \frac{m_2 - m_1}{123.5} = x \text{ mol}$$

$$\text{amount of gas collected} = \frac{V_2 - V_1}{1000} \div 25.3 = y \text{ mol}$$

Then determine the ratio of  $x : y$ . If the ratio is about 2 : 2.5 (or 4 : 5), Equation 4.1 represent the actual decomposition of  $\text{CuCO}_3$ . If the ratio is about 1 : 1, Equation 4.2 represent the actual decomposition of  $\text{CuCO}_3$ .

