

## JC2 Preliminary Examinations

In preparation for General Certificate of Education Advanced Level  
Higher 2

CANDIDATE  
NAME

CT  
GROUP

1	5	S		
---	---	---	--	--

INDEX  
NUMBER

--	--	--	--

## BIOLOGY

**9648/01**

**22 September 2016**

Paper 1 Multiple Choice

**1 hour 15 minutes**

Additional Materials: Multiple Choice Answer Sheet

### READ THESE INSTRUCTIONS FIRST

Write in soft pencil.

Do not use staples, paper clips, highlighters, glue or correction fluid.

Write your name, CT class and index number on the Answer Sheet.

There are **forty** questions on this paper. Answer **all** questions. For each question there are four possible answers **A, B, C** and **D**.

Choose the **one** you consider correct and record your choice in **soft pencil** on the separate Answer Sheet.

Each correct answer will score one mark. A mark will not be deducted for a wrong answer.  
Any rough working should be done in this booklet.

The use of an approved scientific calculator is expected, where appropriate.

This document consists of **27** printed pages and **1** blank page.

**[Turn Over**

- 1 The figure below shows an electron micrograph of a eukaryotic cell.

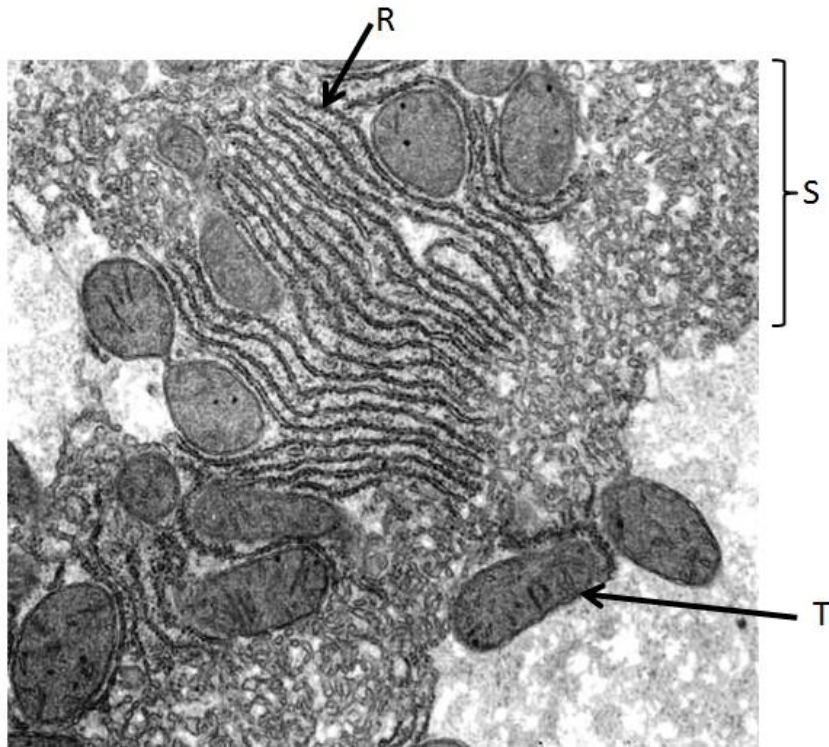

Which of the following options correctly matches the structures **R**, **S** and **T** to their respective functions?

	<b>R</b>	<b>S</b>	<b>T</b>
<b>A</b>	Involved in proteins glycosylation	Site of lipid synthesis	To convert light energy to chemical energy
<b>B</b>	Site of protein synthesis	Site of detoxification reaction	Supplying cellular energy
<b>C</b>	Site of detoxification reaction	Involved in protein glycosylation	Remove worn out organelles
<b>D</b>	Site of protein synthesis	Contains proteins to be secreted	Supplying cellular energy

- 2 Lactic dehydrogenase catalyses the conversion of lactic acid as shown in the following equation.

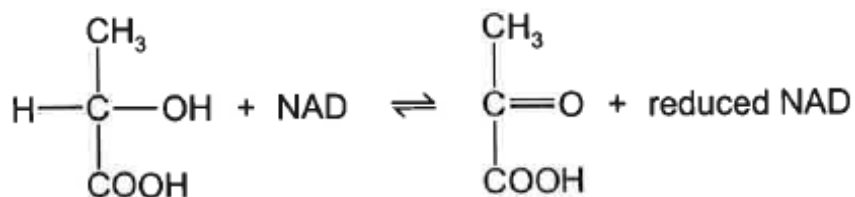

Two forms (isomers) of lactic acid exist, (-) and (+), as shown below.

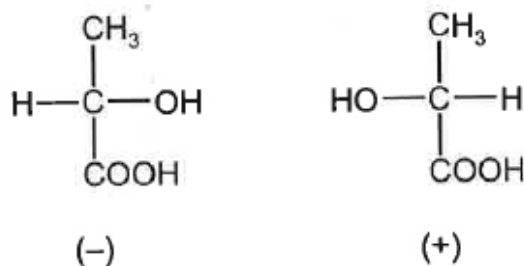

Reduced NAD absorbs ultraviolet light. NAD does not. The activity of bacterial lactic dehydrogenase on two different isomers of lactic acid was compared. The absorbance of ultraviolet light was measured using an ultraviolet spectrophotometer. The graphs show the results.

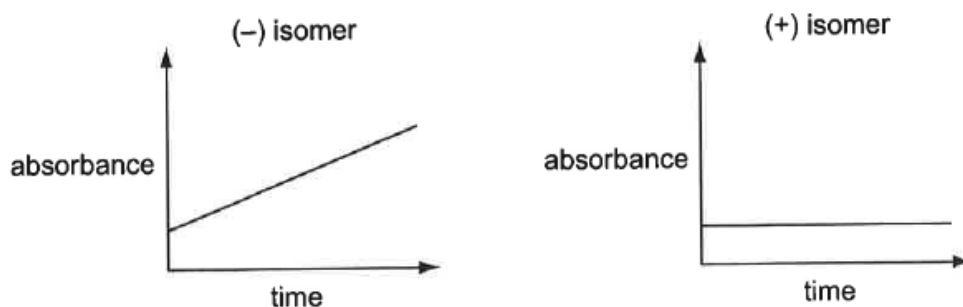

What can be concluded about bacterial lactic dehydrogenase?

- A Molecules of both isomers fit the active site.
- B Molecules of neither isomer fit the active site.
- C The enzyme is specific to the (-) isomer.
- D The enzyme is specific to the (+) isomer.

[Turn Over

- 3 A student uses centrifugation to separate the various subcellular structures of human epithelial cells by size and density.

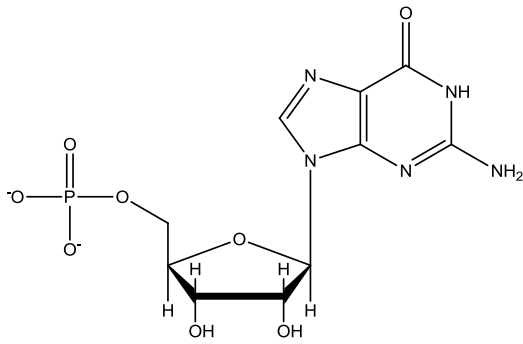

I

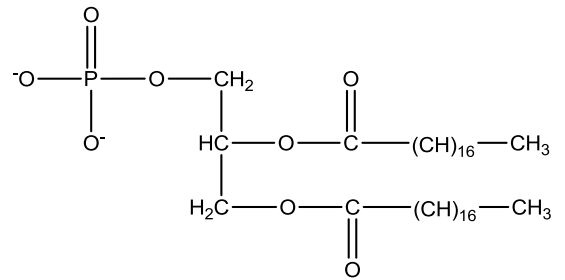

II

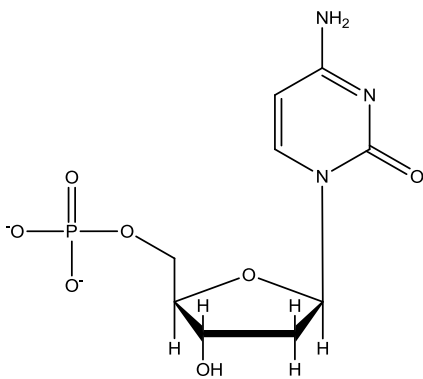

III

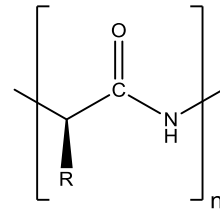

IV

Which of the following molecule(s) would you expect to find in the pellet containing the cell membrane?

- A II only  
 B III only  
 C II and IV only  
 D I, III and IV only

- 4 A molecule of haemoglobin is made up of two  $\alpha$  polypeptide subunits ( $\alpha_1$  and  $\alpha_2$ ) and two  $\beta$  polypeptide subunits ( $\beta_1$  and  $\beta_2$ ).

The relative positions of these subunits change when a deoxygenated haemoglobin molecule takes up oxygen. The axis joining the  $\alpha_2$  and  $\beta_2$  subunits rotates by about  $15^\circ$  in relation to the axis joining the  $\alpha_1$  and  $\beta_1$  subunits, as shown in the diagram.

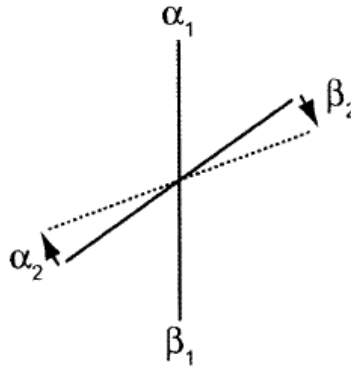

Which statements about this rotation are correct?

- 1 The points of contact between the four subunits are altered.
- 2 The rotation resulting from adding one oxygen molecule to one of the subunits makes it easier to add oxygen to the other subunits.
- 3 The rotation makes different amino acids available for binding oxygen.
- 4 The rotation alters the quaternary structure of the molecule.

- A** 1, 2 and 3 only  
**B** 1, 2 and 4 only  
**C** 1, 3 and 4 only  
**D** 2, 3 and 4 only

- 5 A group of diploid cells with  $x$  amount of DNA and 36 chromosomes each is capable of undergoing mitosis and meiosis.

During which stage(s) could a cell with  $2x$  amount of DNA and 72 chromosomes be found?

- A** anaphase of mitosis only  
**B** anaphase of meiosis I only  
**C** anaphase of mitosis and anaphase of meiosis I  
**D** anaphase of mitosis and anaphase of meiosis II

[Turn Over

**6** Below are statements that describe the control of transcription for genes encoding for enzymes in a metabolic pathway.

- 1 The genes are transcribed as a single transcription unit, with each gene having its own promoter.
- 2 The genes respond similarly to the same set of general transcription factors but respond differently to a certain set of specific transcription factors.
- 3 The genes have various combinations of control elements that enable different activators and repressors to bind and affect the rate of transcription.
- 4 The genes are found close to each other on the chromosome with chromatin remodelling as a form of transcriptional control.

Which combination of statements is true?

- A** 1 only
- B** 2 only
- C** 2 and 3
- D** 3 and 4

**7** The active messenger RNAs (active mRNAs) in tissue cells can be isolated by passing the homogenized cell contents through a fractionating column. The column has short length of uracil nucleotides attached to a solid supporting material. Most molecules of mRNA that pass through the column quickly break up into small pieces and cannot be translated.

The active mRNAs that attached to the column can be separated again by appropriate treatment.

Which statements correctly describe active mRNA?

- 1 Active mRNAs are held to the fractionating column by bonds between adenine and uracil bases.
- 2 Active mRNAs can be released from the fractionating column by breaking hydrogen bonds.
- 3 Only mRNAs with polyadenine tailing can be translated.
- 4 Polyadenine tailing destabilizes mRNA and prevents it from being broken up.

- A** 1 and 2 only
- B** 1, 2 and 3 only
- C** 3 and 4 only
- D** 1, 2, 3 and 4

- 8 RNA transcribed from a length of DNA of a chromosome was found to code for two different protein, as shown in the diagram.

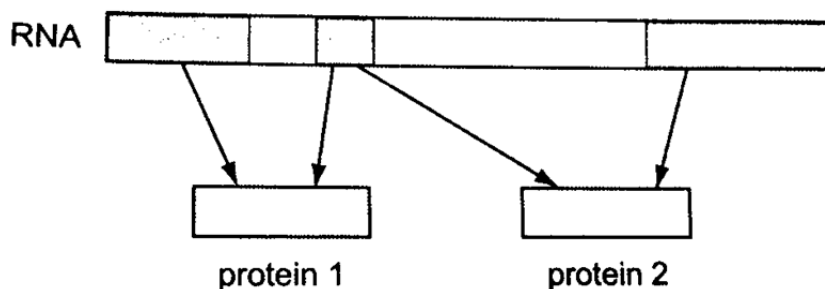

Which is correct?

- A** The DNA from which this RNA was transcribed was part of a eukaryotic chromosome because this is a way of saving space in a small genome.
- B** The DNA from which this RNA was transcribed was part of a eukaryotic chromosome because introns have been edited out of the RNA.
- C** The DNA from which this RNA was transcribed was part of a prokaryotic chromosome because introns have been edited out of the RNA.
- D** The DNA from which this RNA was transcribed was part of a prokaryotic chromosome because this a way of saving space in a small chromosome.
- 9 Below are the descriptions of different gene mutations.
- 1 deletion toward the end of the code sequence
  - 2 insertion in the middle of the code sequence
  - 3 substitution close to the beginning of code sequence

Which row correctly identifies the possible effects of these mutations on the synthesis of polypeptides?

	Premature ending of a polypeptide	A non-functional polypeptide	A polypeptide with unchanged function	A polypeptide with a different function
<b>A</b>	1,2,3	1,2,3	1,2,3	1,2,3
<b>B</b>	1,2,3	2 only	1,3 only	1,2 only
<b>C</b>	1,3 only	1,2,3	3 only	1,2,3
<b>D</b>	2,3 only	2,3 only	1,2,3	2,3 only

[Turn Over

**10** The coding region of a gene is 135 nucleotides long, including both the start and stop codons. Which of the following would be the most likely effect of a single nucleotide deletion at position 102 in the coding region?

- A** Only the active site would be affected.
- B** The entire amino acid sequence of the polypeptide would change.
- C** There would be changes in only the first 34 amino acids.
- D** There would be changes in only the last 10 amino acids.

**11** Three experiments were carried out to investigate the mode of DNA replication in bacteria.

- Experiment 1: Bacteria were grown for many generations with only the light isotope of nitrogen,  $^{14}\text{N}$ , and then allowed to replicate once with the heavy isotope,  $^{15}\text{N}$ .
- Experiment 2: Bacteria were grown for many generations with only the heavy isotope of nitrogen,  $^{15}\text{N}$ , and then allowed to replicate once with the light isotope,  $^{14}\text{N}$ .
- Experiment 3: Bacteria were grown for many generations with only the heavy isotope of nitrogen,  $^{15}\text{N}$ , and then allowed to replicate twice with the light isotope,  $^{14}\text{N}$ .

The figure shows possible DNA molecules U to Z and indicates the varying proportion of nitrogen isotopes present in each DNA molecule.

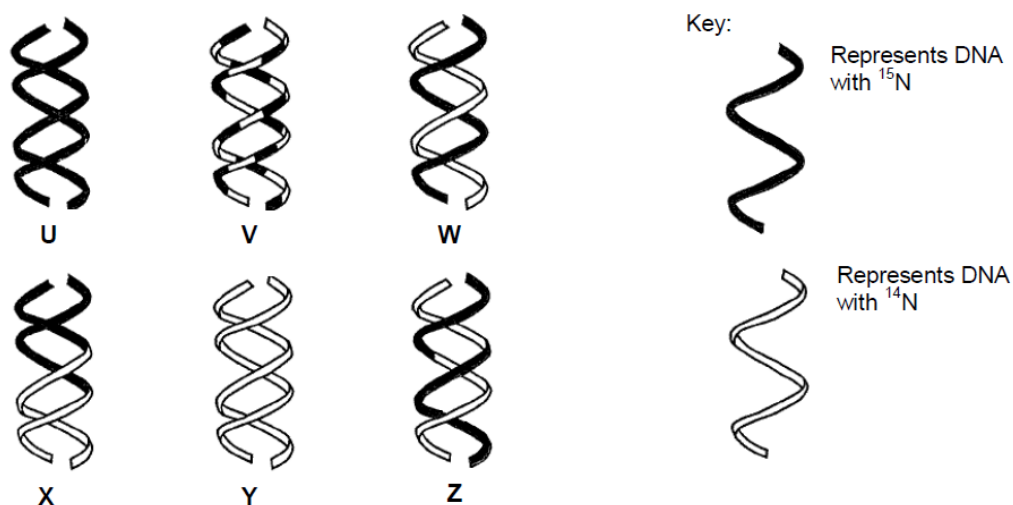

Which of the following products shows the semi-conservative mode of DNA replication?

	Experiment 1	Experiment 2	Experiment 3
<b>A</b>	W	W	W and Y
<b>B</b>	U	W	W and Y
<b>C</b>	W	W	X and Z
<b>D</b>	U	W	V and Z



12 The diagram shows an investigation into bacterial genetics.

The researchers used 2 strains of bacteria. Strain A coded for 3 essential amino acids ( $thr^+ leu^+ thi^+$ ) while Strain B coded for 2 essential amino acids ( $met^+ bio^+$ ). For the 2 strains of bacteria to grow on minimal medium, the bacteria need to encode for all 5 essential amino acids.

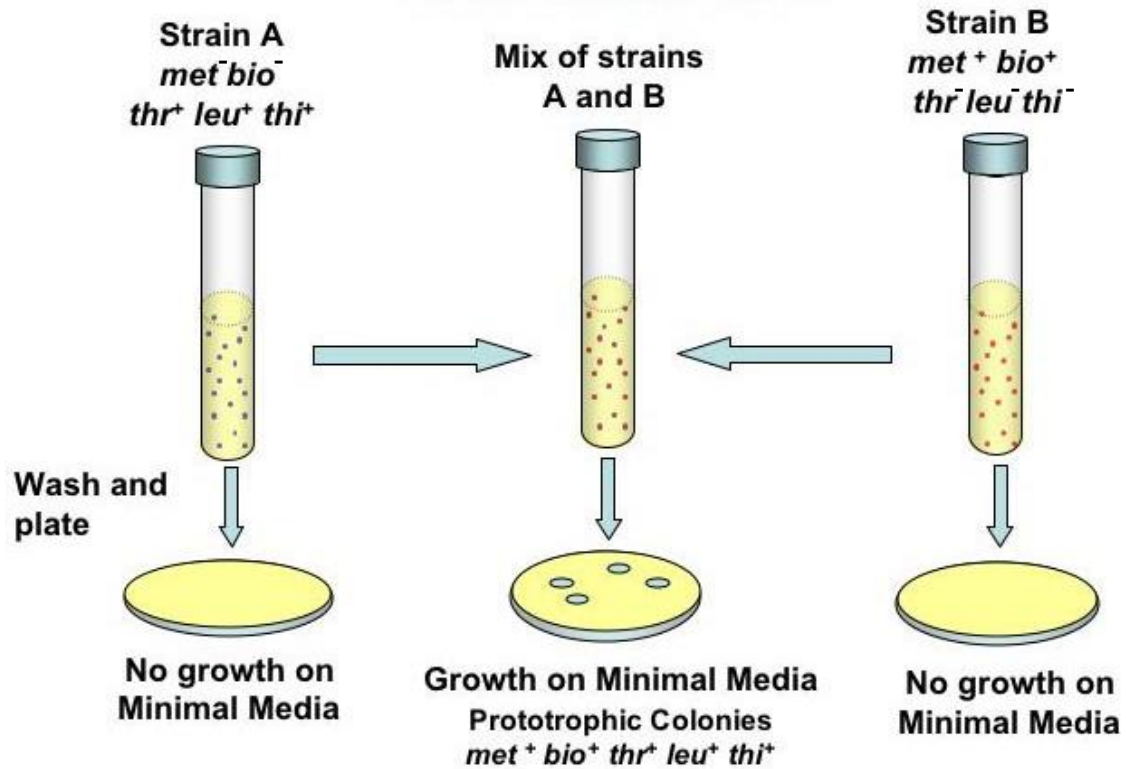

Which process or processes could explain these results?

- 1 Conjugation
- 2 Transduction
- 3 Transformation

- A** 1 only  
**B** 3 only  
**C** 1 and 2  
**D** 1 and 3

[Turn Over

- 13** A single mutation has occurred in an *E. coli* cell. If the structural genes in a *trp* operon were not expressed regardless of the presence or absence of the amino acid tryptophan, which of the following mutations could have taken place?
- 1 The cell had a mutation at the operator of the *trp* operon.
  - 2 The cell had a mutation at the *trpR* gene.
  - 3 The cell had a mutation at the promoter of the *trp* structural genes.
- A** 3 only  
**B** 1 and 2  
**C** 2 and 3  
**D** 1, 2 and 3
- 14** When the *lac* operon for lactose metabolism is switched off, which of the following genes would still be expressed?
- I  $\beta$ -galactosidase gene
  - II RNA polymerase gene
  - III CAP gene
  - IV Repressor gene
- A** I and II  
**B** I and III  
**C** II, III and IV  
**D** All of the above
- 15** Which features of viruses account for them being obligate parasites?
- 1 All viruses are very small, ranging in size from 20 – 300nm.
  - 2 Each virus contains only one type of nucleic acid.
  - 3 Viruses can be crystallised.
  - 4 Viruses cannot synthesis ATP.
  - 5 Viruses have no cellular structure.
  - 6 Viruses have no enzymes involved in metabolism outside a host cell.
- A** 1, 3 and 5  
**B** 1, 4 and 6  
**C** 2, 3 and 5  
**D** 2, 4 and 6

- 16 The diagram below shows the reproductive cycle of the herpes virus which causes cold sores on the mouth. With reference to the diagram below, which of the following statements best describes the herpes virus?

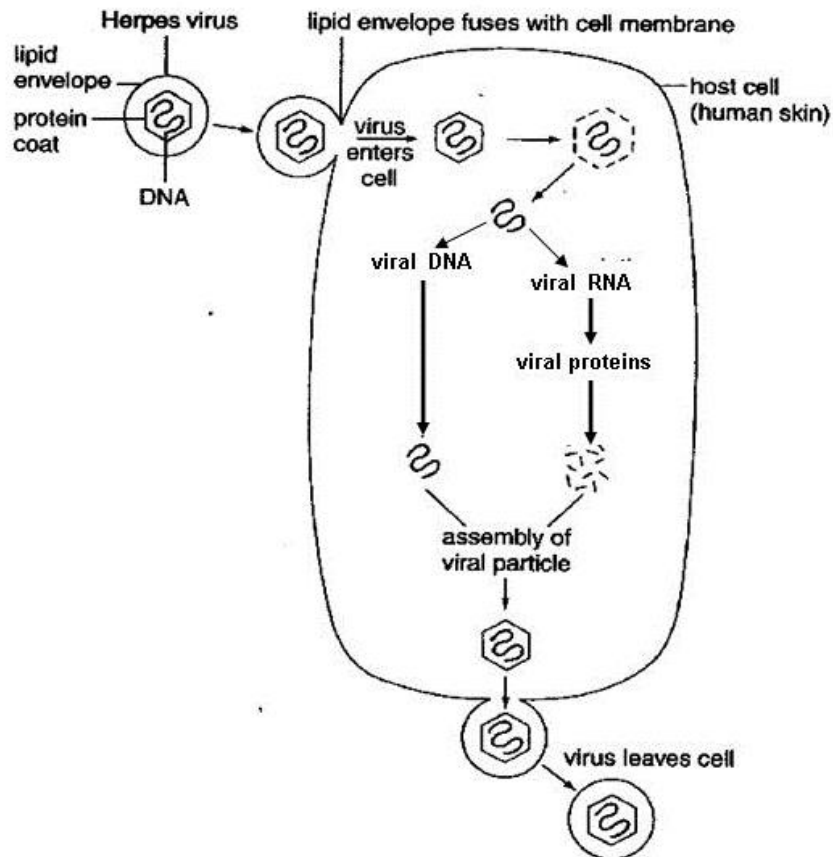

- A It is not a retrovirus as it does not contain RNA as its genetic material.  
 B Its mode of replication is similar to that of HIV.  
 C Its replication cycle includes a lysogenic phase.  
 D Death of the host cell is necessary for the release of the viral progeny.

[Turn Over

- 17** The MDR1 gene codes for a membrane transport protein in mammalian cells. The protein has the ability to prevent the entry of, or remove, molecules such as chemotherapeutic drugs, from cells. Gene amplification of the MDR1 gene can arise from environmental signals.

Which statement is not consistent with the information above?

- A** Amplification of the MDR1 gene in mammalian cancer cells could lead to the cells becoming resistant to chemotherapeutic drugs.
  - B** Cancer cells, with initially the same level of MDR1 gene expression as healthy cells, may respond to chemotherapy by increasing the number of MDR1 genes, which increases expression.
  - C** Development of chemotherapeutic drug resistance can be progressive, rather than spontaneous, and can hinder chemotherapy in patients with cancer.
  - D** Since gene amplification has not arisen by genetic causes, descendant cells from a cancer cell with MDR1 gene amplification will be normal for MDR1 gene expression.
- 18** Cells taken from a human bone cancer multiplied readily in culture. Analysis showed that the cells were unable to produce the protein, RB.

Addition of RB to these cells reduced their rate of division.

Which of the following statement accounts for the observation?

- A** Both chromosomes in the cancer cell carry alleles for tumour suppressor gene.
- B** Both chromosomes in the cancer cell have the allele for tumour suppressor gene deleted.
- C** Both chromosomes in the cancer cell carry alleles for proto-oncogene.
- D** Both chromosomes in the cancer cell have the allele for proto-oncogene deleted.

- 19 The diagram shows the inheritance of a form of breast cancer associated with the presence of just one allele of the autosomal gene BRCA 1.

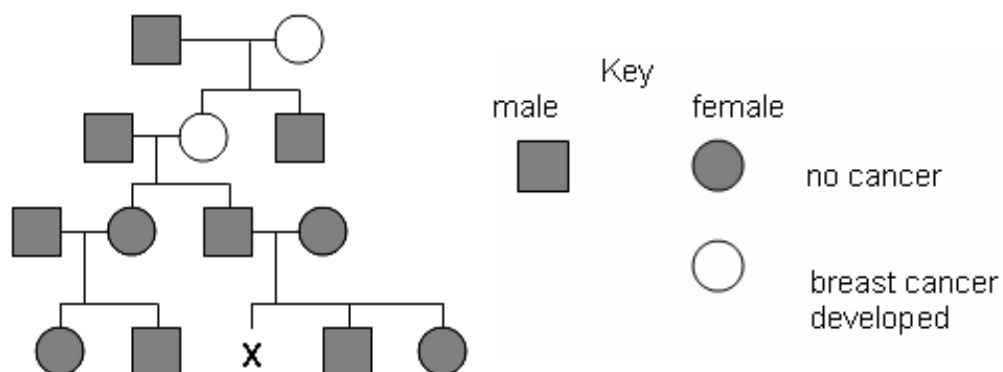

What is the probability that woman **X** inherits the BRCA 1 allele associated with breast cancer?

- A 0.00  
 B 0.25  
 C 0.50  
 D 1.00
- 20 The table summarises a breeding experiment with *Drosophila melanogaster*.

parents	<b>BBNN x bbnn</b>			
F1	<b>BbNn</b>			
test cross	<b>BbNn x bbnn</b>			
test cross offspring	<b>BbNn</b>	<b>bbNn</b>	<b>Bbnn</b>	<b>bbnn</b>
number of test cross offspring	493	125	101	585

key

- B** wild type body colour      **N** normal wings  
**b** black body colour      **n** vestigial wings

What do these results suggest?

- A The alleles N and n are linked.  
 B Independent assortment has not occurred.  
 C The alleles for normal and vestigial wings are codominant.  
 D The gene loci for body colour and wing shape are not linked.

[Turn Over

- 21 The length of the petiole (leaf stalk) in a type of flowering plant is controlled by two genes, P1 and P2. These genes are at different loci on non-homologous chromosomes. Plants with long petioles (30 cm) are homozygous dominant. Plants with short petioles (10 cm) are homozygous recessive. Each dominant allele contributes an equal length to the petiole.

To obtain plants which have medium length petioles (20 cm), a plant breeder carries out the cross below.

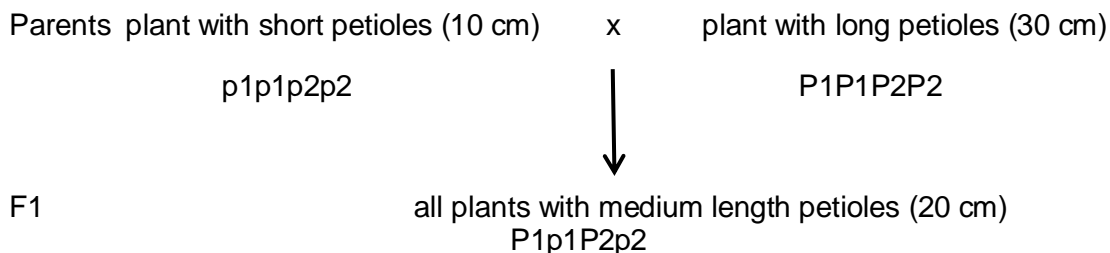

If the F1 generation plants with medium length petioles were allowed to cross, what proportion of their offspring would be expected to have medium length (20 cm) petioles?

- A 0.0625  
 B 0.250  
 C 0.375  
 D 0.5
- 22 The diagram shows the phenotypes of the different shape combs that some breeds of chicken have on their heads.

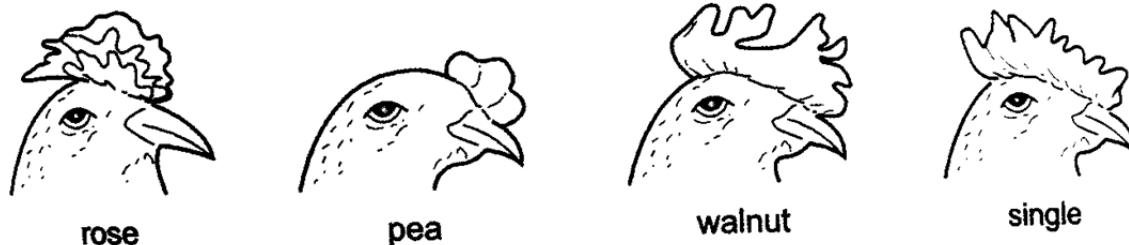

A cross between pure-breeding chickens with rose combs and pure-breeding chickens with pea combs, gave F1 generation offspring with walnut combs.

Interbreeding these F1 generation chickens with walnut combs produced offspring which showed all four of the possible comb phenotypes.

What is the expected phenotypic ratio of the offspring of a cross between a chicken with a single comb and one of the F1 generation chickens with a walnut comb?

- A 1 rose : 1 pea : 1 walnut : 1 single  
 B 1 rose : 2 walnut : 1 pea  
 C 1 walnut : 1 single  
 D 9 walnut : 7 single

- 23 The enzyme phosphofructokinase is involved in the phosphorylation of hexose phosphate sugars during glycolysis. It is involved in the control of the rate of glycolysis, and thus respiration, by end-product inhibition.

Which of the following is a description of this enzyme?

	shape of binding site(s)	substrate	products
<b>A</b>	no allosteric site, active site complementary to ATP and hexose	hexose	hexose phosphate
<b>B</b>	allosteric site complementary to glucose active site complementary to hexose phosphate	hexose phosphate	hexose
<b>C</b>	allosteric site complementary to ATP, active site complementary to ATP and hexose phosphate	hexose phosphate	hexose bisphosphate
<b>D</b>	no allosteric site, active site complementary to hexose bisphosphate	hexose bisphosphate	fructose bisphosphate

- 24 The diagram summarises the reactions of photosynthesis in a plant.

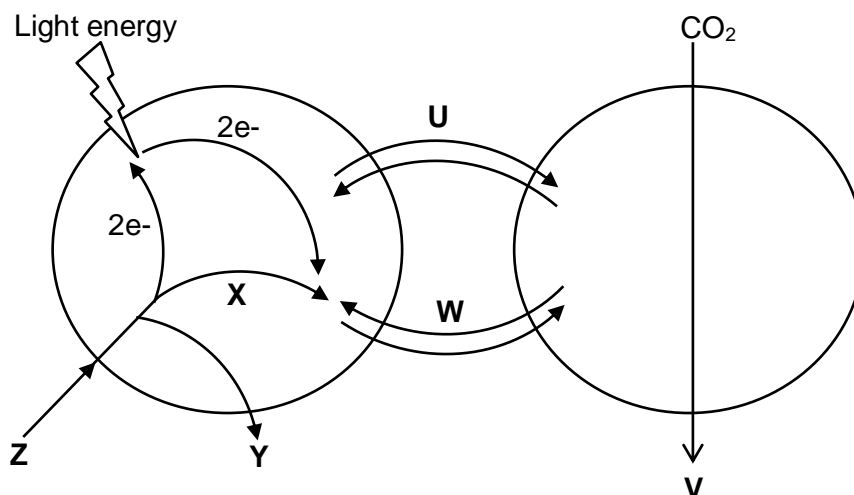

Which of the following correctly identifies the substances involved?

	<b>U</b>	<b>V</b>	<b>W</b>	<b>X</b>	<b>Y</b>	<b>Z</b>
<b>A</b>	triose phosphate	cellulose	ATP	$H^+$	$O_2$	$H_2O$
<b>B</b>	$NADP^+$	triose phosphate	ATP	$H^+$	$H_2O$	$O_2$
<b>C</b>	NADPH	triose phosphate	ADP	$H^+$	$O_2$	$H_2O$
<b>D</b>	NADPH	cellulose	ADP	$H^+$	$H_2O$	$O_2$

[Turn Over

- 25 Most ATP is made in cells by membrane systems that create proton gradients by pumping protons from one compartment to another. Figure below shows two such membrane systems.

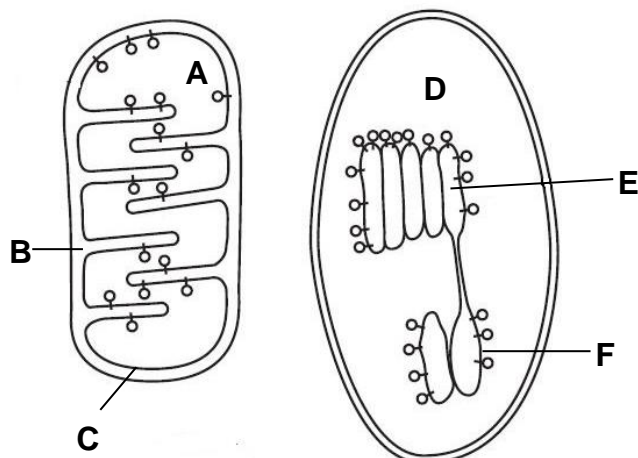

Which statements about the two membrane systems are correct?

- 1 There is production of NADH and ATP within structure **F**.
- 2 Structure **D** is the location in which glyceraldehyde-3-phosphate is produced.
- 3 Protons are pumped from structure **D** to structure **E** against its electrochemical gradient via ATP synthase on structure **F**.
- 4 Electrons flow from structure **B** to structure **A** down its electrochemical gradient via cytochromes.
- 5 Protons diffuse down its proton gradient via ATP synthase on structure **C** and ATP are produced in structure **A**.

- A** 1 and 4  
**B** 2 and 5  
**C** 1, 2 and 5  
**D** 2, 3 and 5



26 The table below shows a description of the activity of 4 drugs.

Drug	Description
1	Inhibit cAMP synthesis
2	Inhibit acetylcholinesterase
3	Block ligand gated $\text{Ca}^{2+}$ channels
4	Block $\text{K}^+$ channels

Which of the following combination shows the consequence for each of the four drugs?

	Drug 1	Drug 2	Drug 3	Drug 4
A	Decreased action potential initiation	Decreased signal transduction efficiency	Decreased action potential initiation	Increased action potential initiation
B	Decreased activation of signalling pathways	Increased action potential initiation	Decreased action potential initiation	Delayed response to stimulus
C	Decreased activation of signalling pathways	Decreased action potential initiation	Increased action potential initiation	Increased action potential initiation
D	Decreased signal transduction efficiency	Increased action potential initiation	Increased action potential initiation	Delayed response to stimulus

[Turn Over

- 27** The ability of organisms to respond rapidly to stimuli is limited by the speed of the impulses in their neurons. The axons of invertebrate neurones lack a myelin sheath. The axons of most vertebrate neurons are myelinated. The graphs show the speed of impulses in these two types of axon.

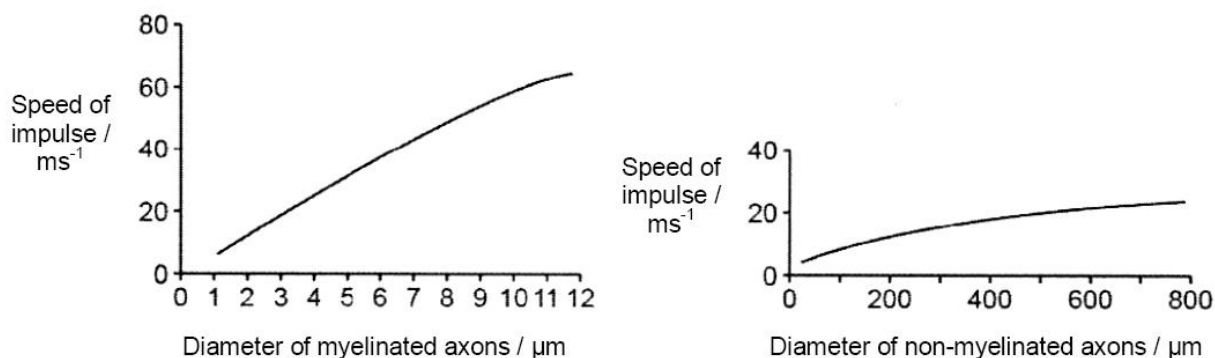

Which of the following statements are correct?

- 1 The action potential in myelinated axons is greater than the action potential in non-myelinated axons.
- 2 The speed of impulses is changed by the diameter of the axon.
- 3 Increasing the diameter of a myelinated axon causes a greater change in the speed of conduction than increasing the diameter of a non-myelinated axon.
- 4 The presence of myelin increases the speed at which impulses are conducted.

- A** 1, 2 and 3 only  
**B** 1, 2 and 4 only  
**C** 2, 3 and 4 only  
**D** 3 and 4 only

- 28 The graph shows the way in which blood glucose concentrations vary over part of a day for a person who does not have diabetes. The set point, indicated by a dotted line, is the blood glucose concentration that is maintained by homeostasis. During this time the person has two meals.

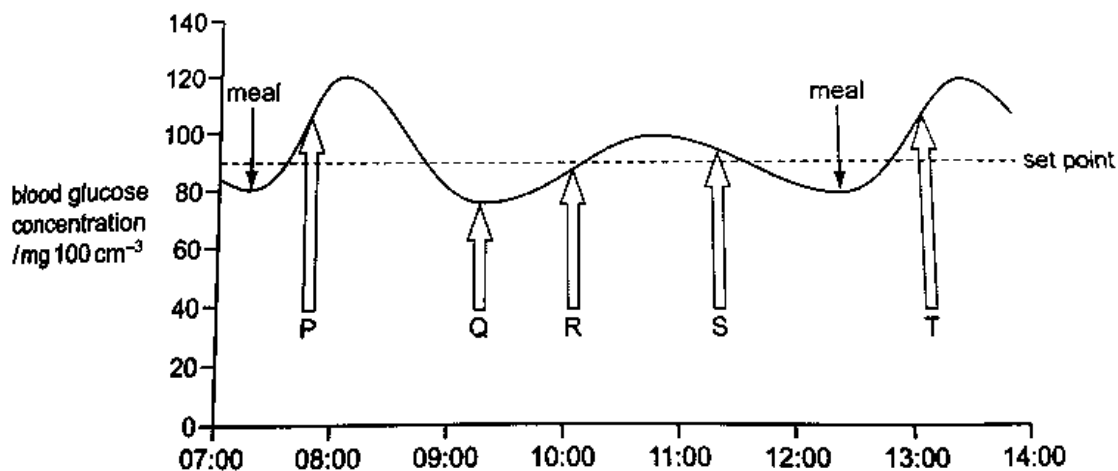

Which row correctly identifies times at which insulin secretion, glucose absorption from the small intestine and conversion of glucose to glycogen occur?

	Insulin secretion	Glucose absorption	Glucose converted to glycogen
<b>A</b>	P, S and T	P and T	P, S and T
<b>B</b>	P, R and T	P and T	S
<b>C</b>	P, S and T	P, R and T	Q and S
<b>D</b>	R and S	P, Q, R and T	P, Q, S and T

- 29 Which statements are acceptable parts of Darwinian evolutionary theory?

- 1 Advantageous behaviour acquired during the lifetime of an individual is likely to be inherited.
- 2 In competition for survival, the more aggressive animals are more likely to survive.
- 3 Species perfectly adapted to a stable environment will continue to evolve.
- 4 Variation between individuals of a species is essential for evolutionary change.

- A** 1, 2 and 4 only  
**B** 2 and 3 only  
**C** 3 and 4 only  
**D** 4 only

[Turn Over

- 30 The table shows the number of estimated nucleotide substitutions that have occurred since the divergence of seven species **a** to **g**.

	<b>b</b>	<b>c</b>	<b>d</b>	<b>e</b>	<b>f</b>	<b>g</b>
<b>a</b>	39	72	128	126	127	269
<b>b</b>		81	130	128	129	268
<b>c</b>			129	127	128	267
<b>d</b>				56	154	271
<b>e</b>					151	268
<b>f</b>						273

Which of the following phylogenetic trees best shows the relationship among these seven species?

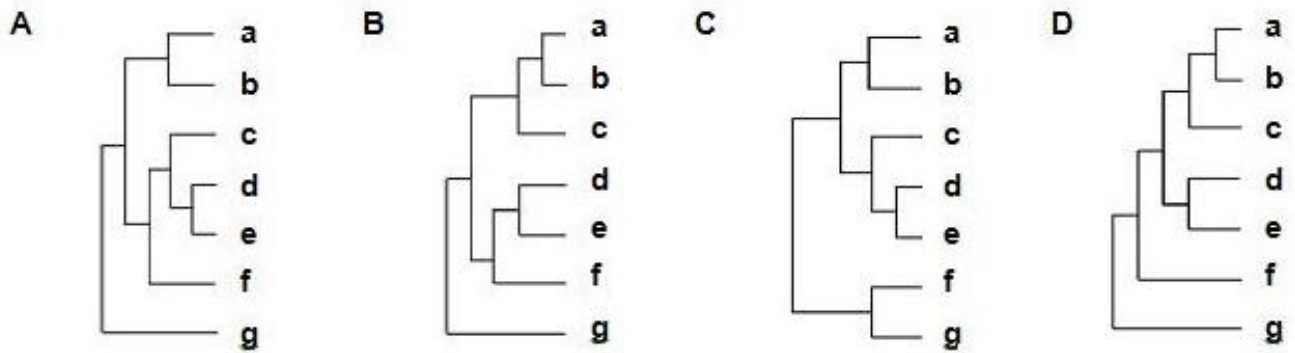

31 A scientist isolated and analysed the nucleotide sequence of the mtDNA of

- 994 modern humans
- One Neanderthal fossil
- Nine chimpanzees.

They compared these sequences. They were able to make human to human, Neanderthal to human and chimpanzee to human comparisons. The number of differences in the nucleotide sequence for each comparison was then recorded. The differences in mtDNA were quite small – no more than a few nucleotide bases – and relatively neutral in terms of evolution.

The results of these comparisons are shown in the graph below.

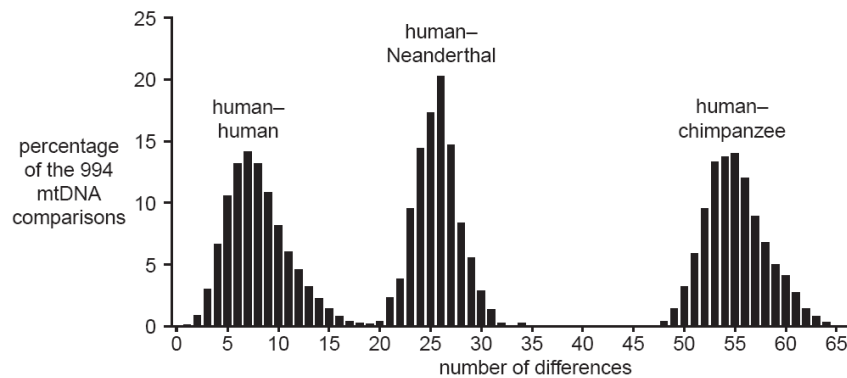

Which of the following statements is **not** true?

- A** This is an example of continuous variation.
- B** The difference between human mtDNA and that of the chimpanzees was greater than between Neanderthals and humans.
- C** Neanderthals are evolutionarily closer to humans than to chimpanzees.
- D** The differences between the DNA of modern humans are much less than the differences between modern humans and Neanderthals.

[Turn Over

- 32 Figure below shows ending of neurone Y in the heart. Stimulation of Y leads to an increase in the concentration of the secondary messenger cyclic AMP (cAMP), in the cytoplasm of the heart cell.

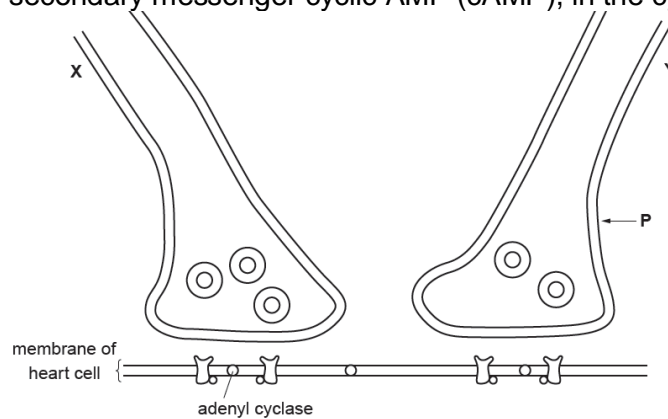

The stages involved in this cell signaling process include:

- 1 Vesicles fuse with post-synaptic membrane and exit via exocytosis and diffuse across the synaptic cleft.
- 2 Voltage-gated calcium channel opens leading to an influx of calcium ions into the neurone.
- 3 Adenylyl cyclase becomes activated and converts ATP to cAMP.
- 4 Calcium ions cause movement of neurotransmitter vesicles towards post-synaptic membrane (along microtubules).
- 5 Neurotransmitter binds to G protein coupled receptor on the membrane of heart cell and activates G protein.

What is the sequence of these stages?

- A 5 → 2 → 4 → 1 → 3  
 B 5 → 2 → 4 → 3 → 1  
 C 2 → 4 → 1 → 5 → 3  
 D 2 → 1 → 4 → 5 → 3
- 33 Chemical T is known to act on the cell signaling pathway of glucagon. It is found to diminish the effect of glucagon.

Which of the following is **not** a possible effect of Chemical T?

- A Chemical T interferes with release of glucagon from the pancreas.  
 B Chemical T activates the hydrolysis of GTP on the G protein.  
 C Chemical T inactivates the enzyme adenylyl cyclase.  
 D Chemical T act as a competitive inhibitor of the protein kinase.

- 34 The diagram below shows an autoradiograph, post-gel electrophoresis, showing the restriction fragments obtained from various members of a family with respect to a disease.

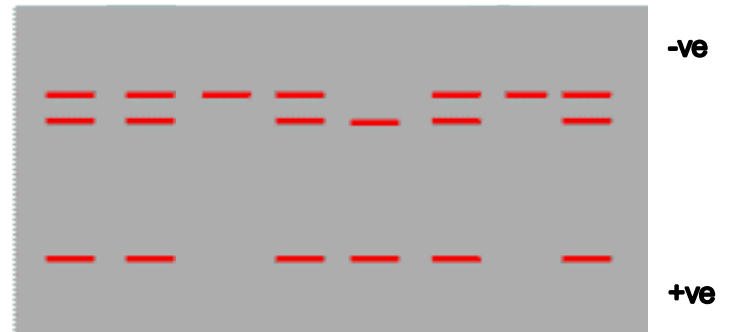
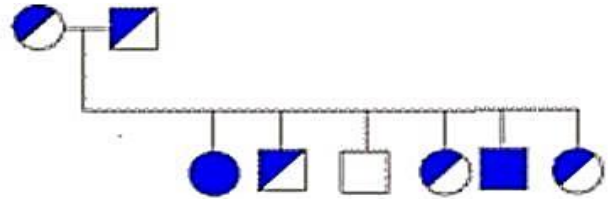
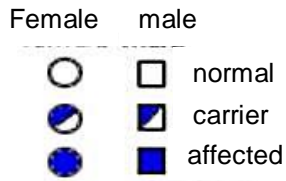

Which of the following statements can be concluded from this autoradiograph?

- 1 The recessive allele is missing a restriction site.
- 2 The disease is autosomal recessive.
- 3 The radioactive probe is able to bind to a specific sequence on the recessive allele only.

- A** 1 and 2  
**B** 2 and 3  
**C** 1 and 3  
**D** All of the above

[Turn Over

35 Plasmid X can serve as a vector for the insertion of genes to be cloned.

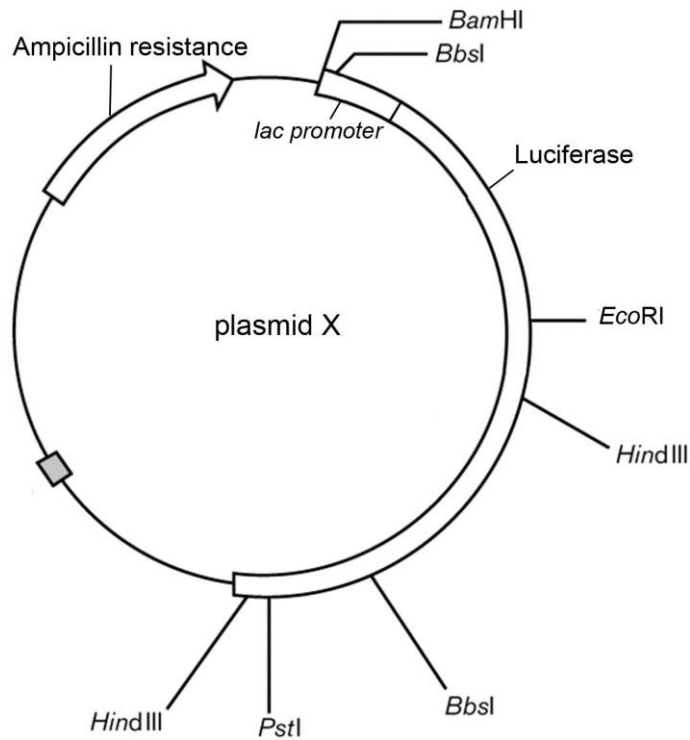

Which of the following options will allow the selection of the colonies containing the recombinant form of plasmid X?

	Selection medium	Phenotype of colonies that contain the inserted gene
<b>A</b>	Containing ampicillin and lactose	White colonies
<b>B</b>	Containing ampicillin and luciferase	Colonies that emit light
<b>C</b>	Containing ampicillin, lactose and luciferin	White colonies
<b>D</b>	Containing ampicillin, lactose and luciferin	Colonies that emit light



- 36 The dashed lines in the template sequence represent a long sequence of bases to be amplified.

Template

5' ATTCGGACTTG ----- GTCCAGCTAGAGG 3'

3' TAAGCCTGAAC ----- CAGGTCGATCTCC 5'

Which of the following sets of primers can be used in the PCR for the amplification of the following DNA sequence?

- A 3' TAAGCCT 5' & 5' CTAGAGG 3'  
 B 5' ATTCGGA 3' & 3' GATCTCC 5'  
 C 3' UAAGCCU 5' & 5' CUAGAGG 3'  
 D 5' AUUCGGA 3' & 3' GAUCUCC 5'
- 37 Cystic fibrosis (CF) is an autosomal recessive genetic disorder. An individual must have two copies of the mutated CFTR gene to express the disease phenotype. One of the most common CF-causing mutation resulted in a loss of phenylalanine located at position 508 of the protein.

The DNA sequence of the CF locus from the offspring of 2 carriers are removed and separated by gel electrophoresis.

Which pattern of bands corresponds to two of the offspring that are phenotypically normal?

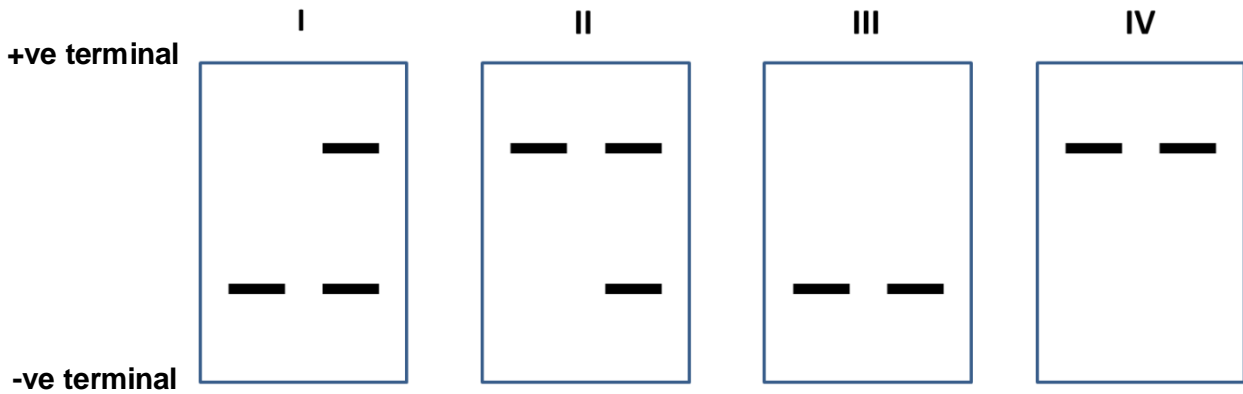

- A I only  
 B II only  
 C I and III  
 D II and IV

[Turn Over

- 38** The statements are about the preparation and application of DNA libraries.
- 1 A cDNA library allows the study of the functions of introns of specific genes
  - 2 A genomic library enables detection of genes that, in the host, have no detectable level of expression.
  - 3 Alternative splicing can be studied using a cDNA library
  - 4 The preparation of a genomic DNA library requires restriction enzyme, reverse transcriptase and DNA ligase

Which statements are correct?

- A** 1, 2 and 4
  - B** 1 and 4 only
  - C** 2, 3 and 4
  - D** 2 and 3 only
- 39** Stem cells are found in many tissues that require frequent cell replacement such as the skin, the intestine or the blood.

However, within their own environments, a bone marrow cell cannot be induced to produce a skin cell and a skin cell cannot be induced to produce a bone marrow cell.

Which statement explains this?

- A** Different stem cells have only the genes required for their particular cell line.
- B** Genes not required for a particular cell line are methylated.
- C** Genes not required for a particular cell line are removed using restriction enzymes.
- D** mRNA that is not required for a particular cell line is destroyed.

**40** Gene therapy is used to treat inherited diseases such as cystic fibrosis. Some of the scientific and ethical concerns about gene therapy are listed below.

- 1 Most gene therapy must be repeated in succeeding generations since germ cells are not involved.
- 2 Genetically modified organisms used in producing the gene therapy may escape into the environment with unforeseen consequences.
- 3 Putting genes into the germ line affects subsequent generations and is banned in many countries.
- 4 The same techniques for treating serious, life-threatening conditions may be used to try to change other things such as intelligence and skin colour.
- 5 Viral vectors, such as those used in the treatment of cystic fibrosis, have been known to produce harmful side-effects.

Which row identifies the types of concern?

	Scientific concerns	ethical concerns
<b>A</b>	1 and 2	3, 4 and 5
<b>B</b>	2 and 4	1, 3 and 5
<b>C</b>	1 and 5	2, 3 and 4
<b>D</b>	3, 4 and 5	1 and 2

**BLANK PAGE**

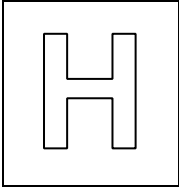

## JC2 Preliminary Examinations

In preparation for General Certificate of Education Advanced Level  
Higher 2

CANDIDATE  
NAME

--

CT  
GROUP

1	5	S	
---	---	---	--

INDEX  
NUMBER

--	--	--	--

## BIOLOGY

**9648/01**

**22 September 2016**

Paper 1 Multiple Choice

**1 hour 15 minutes**

Additional Materials: Multiple Choice Answer Sheet

### READ THESE INSTRUCTIONS FIRST

Write in soft pencil.

Do not use staples, paper clips, highlighters, glue or correction fluid.

Write your name, CT class and index number on the Answer Sheet.

There are **forty** questions on this paper. Answer **all** questions. For each question there are four possible answers **A, B, C** and **D**.

Choose the **one** you consider correct and record your choice in **soft pencil** on the separate Answer Sheet.

Each correct answer will score one mark. A mark will not be deducted for a wrong answer.  
Any rough working should be done in this booklet.

The use of an approved scientific calculator is expected, where appropriate.

This document consists of **27** printed pages and **1** blank page.

**[Turn Over**

- 1 The figure below shows an electron micrograph of an eukaryotic cell.

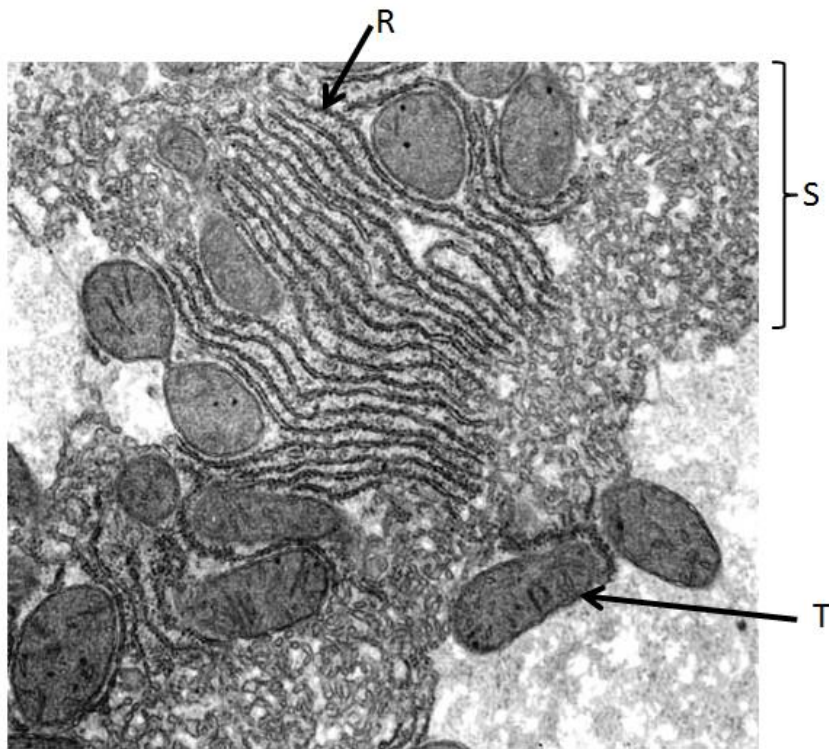

Which of the following option correctly matches the structures **R**, **S** and **T** to their respective functions?

	<b>R</b>	<b>S</b>	<b>T</b>
<b>A</b>	Involved in proteins glycosylation	Site of lipid synthesis	To convert light energy to chemical energy
<b>B</b>	Site of protein synthesis	Site of detoxification reaction	Supplying cellular energy
<b>C</b>	Site of detoxification reaction	Involved in protein glycosylation	Remove worn out organelles
<b>D</b>	Site of protein synthesis	Contains proteins to be secreted	Supplying cellular energy

- 2 Lactic dehydrogenase catalyses the conversion of lactic acid as shown in the following equation.

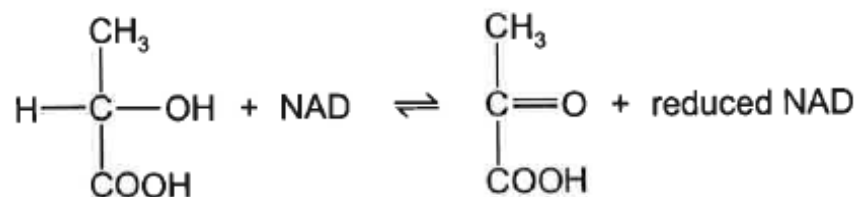

Two forms (isomers) of lactic acid exist, (-) and (+), as shown below.

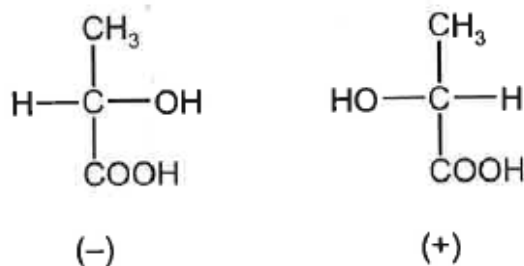

Reduced NAD absorbs ultraviolet light. NAD does not. The activity of bacterial lactic dehydrogenase on two different isomers of lactic acid was compared. The absorbance of ultraviolet light was measured using an ultraviolet spectrophotometer. The graphs show the results.

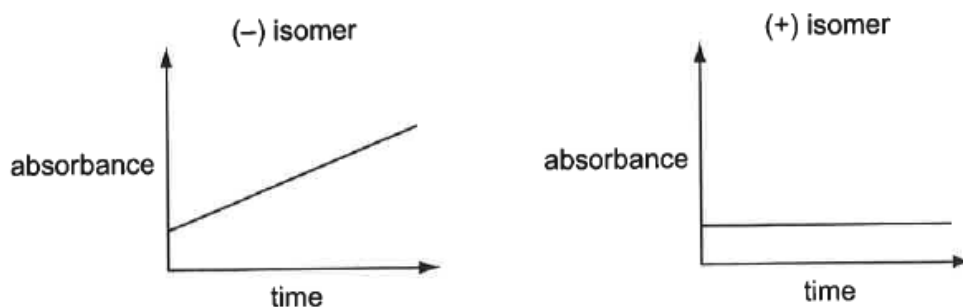

What can be concluded about bacterial lactic dehydrogenase?

- A Molecules of both isomers fit the active site.
- B Molecules of neither isomer fit the active site.
- C The enzyme is specific to the (-) isomer.
- D The enzyme is specific to the (+) isomer.

[Turn Over

- 3 A student uses centrifugation to separate the various subcellular structures of human epithelial cells by size and density.

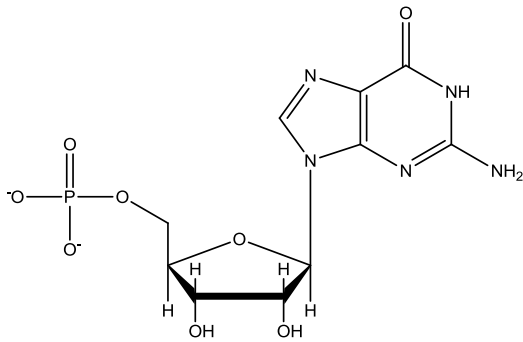

I

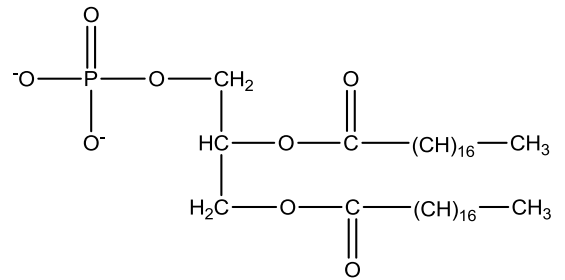

II

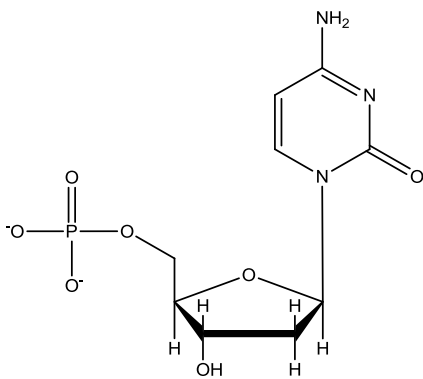

III

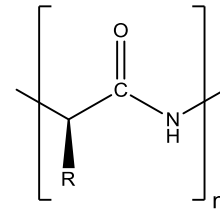

IV

Which of the following molecule(s) would you expect to find in the pellet containing the cell membrane?

- A II only  
 B III only  
 C II and IV only  
 D I, III and IV only



- 4 A molecule of haemoglobin is made up of two  $\alpha$  polypeptide subunits ( $\alpha_1$  and  $\alpha_2$ ) and two  $\beta$  polypeptide subunits ( $\beta_1$  and  $\beta_2$ ).

The relative positions of these subunits change when a deoxygenated haemoglobin molecule takes up oxygen. The axis joining the  $\alpha_2$  and  $\beta_2$  subunits rotates by about  $15^\circ$  in relation to the axis joining the  $\alpha_1$  and  $\beta_1$  subunits, as shown in the diagram.

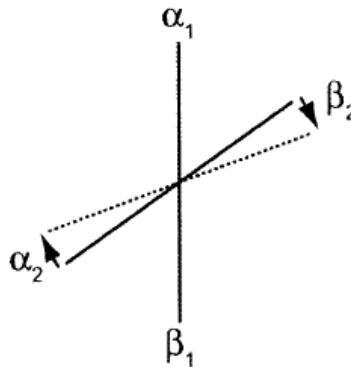

Which statements about this rotation are correct?

- 1 The points of contact between the four subunits are altered.
- 2 The rotation resulting from adding one oxygen molecule to one of the subunits makes it easier to add oxygen to the other subunits.
- 3 The rotation makes different amino acids available for binding oxygen.
- 4 The rotation alters the quaternary structure of the molecule.

A 1, 2 and 3 only

**B 1, 2 and 4 only**

C 1, 3 and 4 only

D 2, 3 and 4 only

- 5 A group of diploid cells with  $x$  amount of DNA and 36 chromosomes each is capable of undergoing mitosis and meiosis.

During which stage(s) could a cell with  $2x$  amount of DNA and 72 chromosomes be found?

**A anaphase of mitosis only**

B anaphase of meiosis I only

C anaphase of mitosis and anaphase of meiosis I

D anaphase of mitosis and anaphase of meiosis II

[Turn Over

6 Below are statements that describe the control of transcription for genes encoding for enzymes in a metabolic pathway.

- 1 The genes are transcribed as a single transcription unit, with each gene having its own promoter.
- 2 The genes respond similarly to the same set of general transcription factors but respond differently to a certain set of specific transcription factors.
- 3 The genes have various combinations of control elements that enable different activators and repressors to bind and affect the rate of transcription.
- 4 The genes are found close to each other on the chromosome with chromatin remodelling as a form of transcriptional control.

Which combination of statements is true?

- A 1 only
- B 2 only
- C 2 and 3**
- D 3 and 4

7 The active messenger RNAs (active mRNAs) in tissue cells can be isolated by passing the homogenized cell contents through a fractionating column. The column has short length of uracil nucleotides attached to a solid supporting material. Most molecules of mRNA that pass through the column quickly break up into small pieces and cannot be translated.

The active mRNAs that attached to the column can be separated again by appropriate treatment.

Which statements correctly describe active mRNA?

- 1 Active mRNAs are held to the fractionating column by bonds between adenine and uracil bases.
- 2 Active mRNAs can be released from the fractionating column by breaking hydrogen bonds.
- 3 Only mRNAs with polyadenine tailing can be translated.
- 4 Polyadenine tailing destabilizes mRNA and prevents it from being broken up.

- A 1 and 2 only
- B 1, 2 and 3 only**
- C 3 and 4 only
- D 1, 2, 3 and 4

- 8 RNA transcribed from a length of DNA of a chromosome was found to code for two different protein, as shown in the diagram.

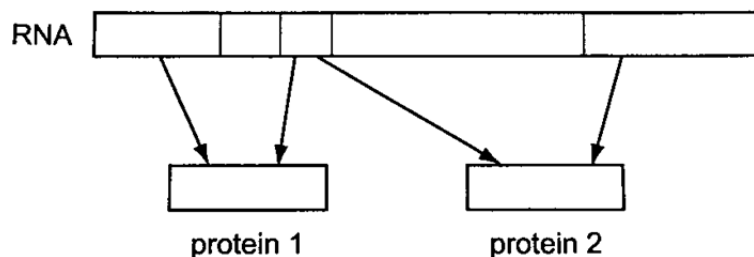

Which is correct?

- A The DNA from which this RNA was transcribed was part of a eukaryotic chromosome because this is a way of saving space in a small genome.
- B The DNA from which this RNA was transcribed was part of a eukaryotic chromosome because introns have been edited out of the RNA.**
- C The DNA from which this RNA was transcribed was part of a prokaryotic chromosome because introns have been edited out of the RNA.
- D The DNA from which this RNA was transcribed was part of a prokaryotic chromosome because this a way of saving space in a small chromosome.
- 9 Below are the descriptions of different gene mutations.

- 1 deletion toward the end of the code sequence
- 2 insertion in the middle of the code sequence
- 3 substitution close to the beginning of code sequence

Which row correctly identifies the possible effects of these mutations on the synthesis of polypeptides?

	Premature ending of a polypeptide	A non-functional polypeptide	A polypeptide with unchanged function	A polypeptide with a different function
<b>A</b>	1,2,3	1,2,3	1,2,3	1,2,3
<b>B</b>	1,2,3	2 only	1,3 only	1,2 only
<b>C</b>	1,3 only	1,2,3	3 only	1,2,3
<b>D</b>	2,3 only	2,3 only	1,2,3	2,3 only

[Turn Over

10 The coding region of a gene is 135 nucleotides long, including both the start and stop codons. Which of the following would be the most likely effect of a single nucleotide deletion at position 102 in the coding region?

- A Only the active site would be affected.
- B The entire amino acid sequence of the polypeptide would change.
- C There would be changes in only the first 34 amino acids.
- D There would be changes in only the last 10 amino acids.

11 Three experiments were carried out to investigate the mode of DNA replication in bacteria.

- Experiment 1: Bacteria were grown for many generations with only the light isotope of nitrogen,  $^{14}\text{N}$ , and then allowed to replicate once with the heavy isotope,  $^{15}\text{N}$ .
- Experiment 2: Bacteria were grown for many generations with only the heavy isotope of nitrogen,  $^{15}\text{N}$ , and then allowed to replicate once with the light isotope,  $^{14}\text{N}$ .
- Experiment 3: Bacteria were grown for many generations with only the heavy isotope of nitrogen,  $^{15}\text{N}$ , and then allowed to replicate twice with the light isotope,  $^{14}\text{N}$ .

The figure shows possible DNA molecules U to Z and indicates the varying proportion of nitrogen isotopes present in each DNA molecule.

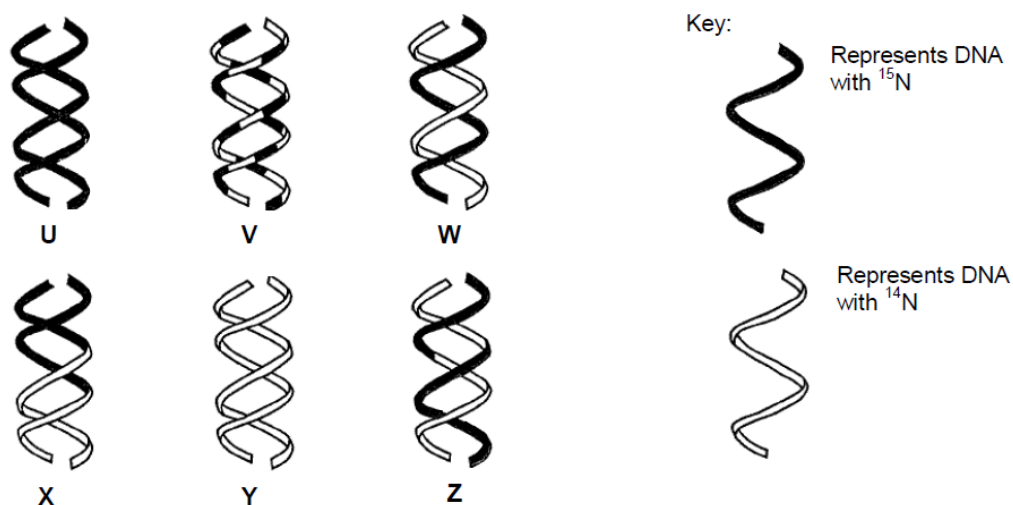

Which of the following products shows the semi-conservative mode of DNA replication?

	Experiment 1	Experiment 2	Experiment 3
<b>A</b>	<b>W</b>	<b>W</b>	<b>W and Y</b>
<b>B</b>	U	W	W and Y
<b>C</b>	W	W	X and Z
<b>D</b>	U	W	V and Z

12 The diagram shows an investigation into bacterial genetics.

The researchers used 2 strains of bacteria. Strain A coded for 3 essential amino acids ( $thr^+ leu^+ thi^+$ ) while Strain B coded for 2 essential amino acids ( $met^+ bio^+$ ). For the 2 strains of bacteria to grow on minimal medium, the bacteria need to encode for all 5 essential amino acids.

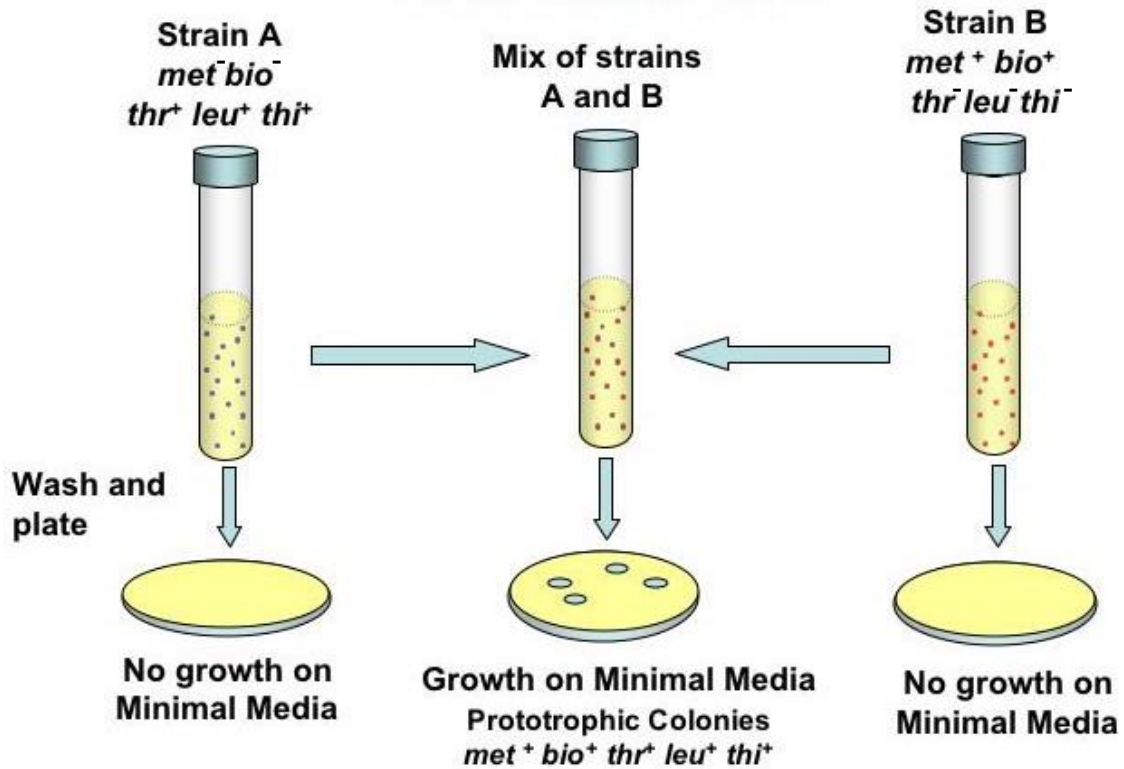

Which process or processes could explain these results?

- 1 Conjugation
- 2 Transduction
- 3 Transformation

- A** 1 only  
**B** 3 only  
**C** 1 and 2  
**D** 1 and 3

[Turn Over

- 13** A single mutation has occurred in an *E. coli* cell. If the structural genes in a *trp* operon were not expressed regardless of the presence or absence of the amino acid tryptophan, which of the following mutations could have taken place?
- 1 The cell had a mutation at the operator of the *trp* operon.
  - 2 The cell had a mutation at the *trpR* gene.
  - 3 The cell had a mutation at the promoter of the *trp* structural genes.
- A** 3 only  
**B** 1 and 2  
**C** 2 and 3  
**D** 1, 2 and 3
- 14** When the *lac* operon for lactose metabolism is switched off, which of the following genes would still be expressed?
- I  $\beta$ -galactosidase gene
  - II RNA polymerase gene
  - III CAP gene
  - IV Repressor gene
- A** I and II  
**B** I and III  
**C** II, III and IV  
**D** All of the above
- 15** Which features of viruses account for them being obligate parasites?
- 1 All viruses are very small, ranging in size from 20 – 300nm.
  - 2 Each virus contains only one type of nucleic acid.
  - 3 Viruses can be crystallised.
  - 4 Viruses cannot synthesis ATP.
  - 5 Viruses have no cellular structure.
  - 6 Viruses have no enzymes involved in metabolism outside a host cell.
- A** 1, 3 and 5  
**B** 1, 4 and 6  
**C** 2, 3 and 5  
**D** 2, 4 and 6

- 16 The diagram below shows the reproductive cycle of the herpes virus which causes cold sores on the mouth. With reference to the diagram below, which of the following statements best describes the herpes virus?

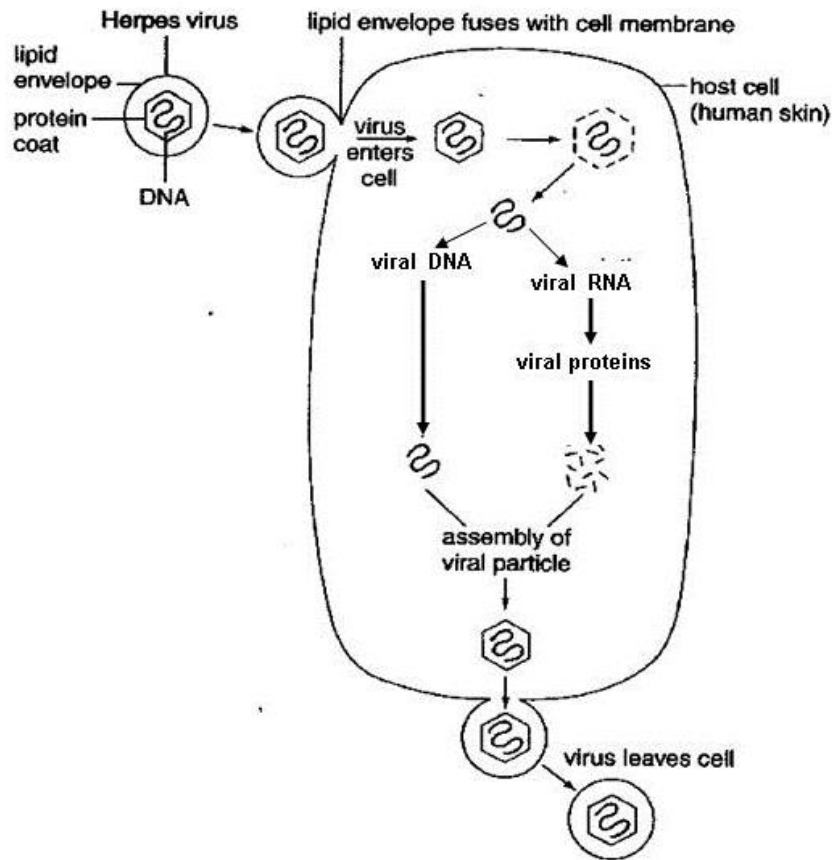

- A** It is not a retrovirus as it does not contain RNA as its genetic material.
- B** Its mode of replication is similar to that of HIV.
- C** Its replication cycle includes a lysogenic phase.
- D** Death of the host cell is necessary for the release of the viral progeny.

[Turn Over

- 17 The MDR1 gene codes for a membrane transport protein in mammalian cells. The protein has the ability to prevent the entry of, or remove, molecules such as chemotherapeutic drugs, from cells. Gene amplification of the MDR1 gene can arise from environmental signals.

Which statement is not consistent with the information above?

- A Amplification of the MDR1 gene in mammalian cancer cells could lead to the cells becoming resistant to chemotherapeutic drugs.
  - B Cancer cells, with initially the same level of MDR1 gene expression as healthy cells, may respond to chemotherapy by increasing the number of MDR1 genes, which increases expression.
  - C Development of chemotherapeutic drug resistance can be progressive, rather than spontaneous, and can hinder chemotherapy in patients with cancer.
  - D Since gene amplification has not arisen by genetic causes, descendant cells from a cancer cell with MDR1 gene amplification will be normal for MDR1 gene expression.
- 18 Cells taken from a human bone cancer multiplied readily in culture. Analysis showed that the cells were unable to produce the protein, RB.

Addition of RB to these cells reduced their rate of division.

Which of the following statement accounts for the observation?

- A Both chromosomes in the cancer cell carry alleles for tumour suppressor gene.
- B Both chromosomes in the cancer cell have the allele for tumour suppressor gene deleted.
- C Both chromosomes in the cancer cell carry alleles for proto-oncogene.
- D Both chromosomes in the cancer cell have the allele for proto-oncogene deleted.



19 The diagram shows the inheritance of a form of breast cancer associated with the presence of just one allele of the autosomal gene BRCA 1.

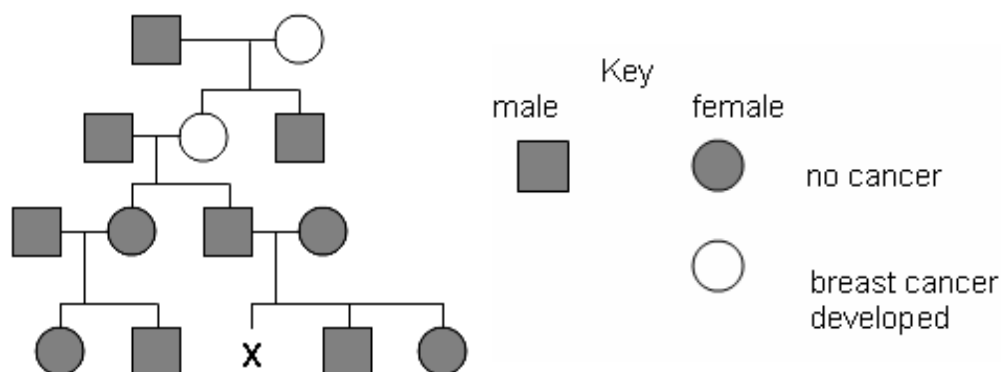

What is the probability that woman X inherits the BRCA 1 allele associated with breast cancer?

- A 0.00
- B 0.25
- C 0.50
- D 1.00

20 The table summarises a breeding experiment with *Drosophila melanogaster*.

parents	<b>BBNN x bbnn</b>			
F1	<b>BbNn</b>			
test cross	<b>BbNn x bbnn</b>			
test cross offspring	<b>BbNn</b>	<b>bbNn</b>	<b>Bbnn</b>	<b>bbnn</b>
number of test cross offspring	493	125	101	585

key

- |          |                       |          |                 |
|----------|-----------------------|----------|-----------------|
| <b>B</b> | wild type body colour | <b>N</b> | normal wings    |
| <b>b</b> | black body colour     | <b>n</b> | vestigial wings |

What do these results suggest?

- A The alleles N and n are linked.
- B Independent assortment has not occurred.
- C The alleles for normal and vestigial wings are codominant.
- D The gene loci for body colour and wing shape are not linked.

[Turn Over



- 23 The enzyme phosphofructokinase is involved in the phosphorylation of hexose phosphate sugars during glycolysis. It is involved in the control of the rate of glycolysis, and thus respiration, by end-product inhibition.

Which of the following is a description of this enzyme?

	shape of binding site(s)	substrate	products
<b>A</b>	no allosteric site, active site complementary to ATP and hexose	hexose	hexose phosphate
<b>B</b>	allosteric site complementary to glucose active site complementary to hexose phosphate	hexose phosphate	hexose
<b>C</b>	allosteric site complementary to ATP, active site complementary to ATP and hexose phosphate	hexose phosphate	hexose bisphosphate
<b>D</b>	no allosteric site, active site complementary to hexose bisphosphate	hexose bisphosphate	fructose bisphosphate

- 24 The diagram summarises the reactions of photosynthesis in a plant.

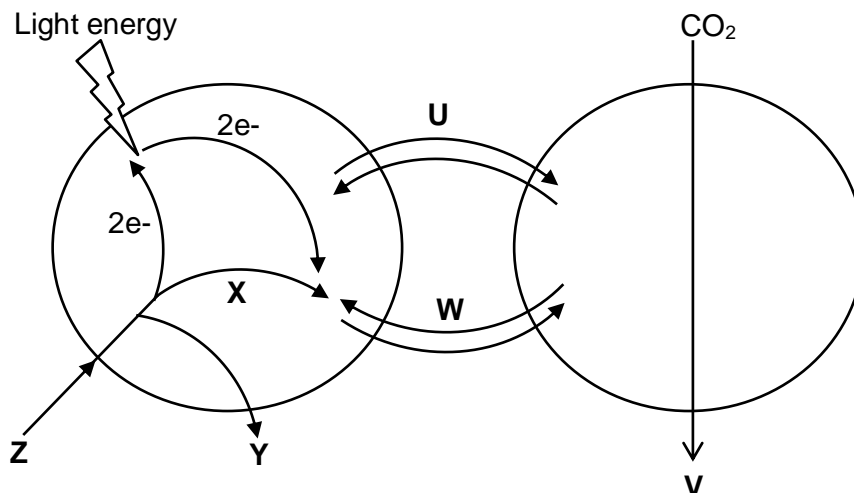

Which of the following correctly identifies the substances involved?

	U	V	W	X	Y	Z
<b>A</b>	triose phosphate	cellulose	ATP	$H^+$	$O_2$	$H_2O$
<b>B</b>	$NADP^+$	triose phosphate	ATP	$H^+$	$H_2O$	$O_2$
<b>C</b>	<b>NADPH</b>	<b>triose phosphate</b>	<b>ADP</b>	<b><math>H^+</math></b>	<b><math>O_2</math></b>	<b><math>H_2O</math></b>
<b>D</b>	NADPH	cellulose	ADP	$H^+$	$H_2O$	$O_2$

[Turn Over

- 25 Most ATP is made in cells by membrane systems that create proton gradients by pumping protons from one compartment to another. Figure below shows two such membrane systems.

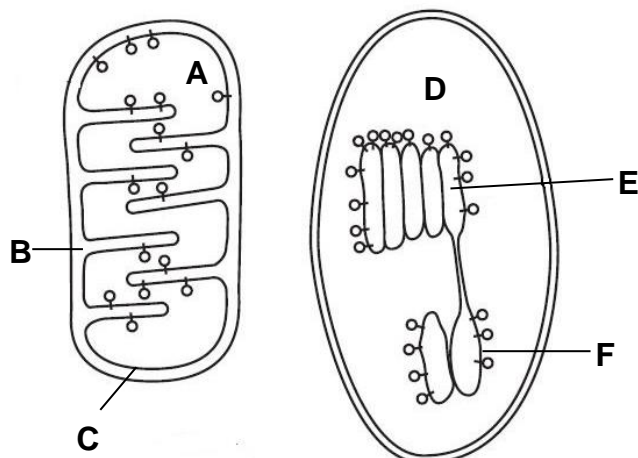

Which statements about the two membrane systems are correct?

- 1 There is production of NADH and ATP within structure **F**.
- 2 Structure **D** is the location in which glyceraldehyde-3-phosphate is produced.
- 3 Protons are pumped from structure **D** to structure **E** against its electrochemical gradient via ATP synthase on structure **F**.
- 4 Electrons flow from structure **B** to structure **A** down its electrochemical gradient via cytochromes.
- 5 Protons diffuse down its proton gradient via ATP synthase on structure **C** and ATP are produced in structure **A**.

- A** 1 and 4  
**B** 2 and 5  
**C** 1, 2 and 5  
**D** 2, 3 and 5

26 The table below shows a description of the activity of 4 drugs.

Drug	Description
1	Inhibit cAMP synthesis
2	Inhibit acetylcholinesterase
3	Block ligand gated $\text{Ca}^{2+}$ channels
4	Block $\text{K}^+$ channels

Which of the following combination shows the consequence for each of the four drugs?

	Drug 1	Drug 2	Drug 3	Drug 4
<b>A</b>	Decreased action potential initiation	Decreased signal transduction efficiency	Decreased action potential initiation	Increased action potential initiation
<b>B</b>	Decreased activation of signalling pathways	Increased action potential initiation	Decreased action potential initiation	Delayed response to stimulus
<b>C</b>	Decreased activation of signalling pathways	Decreased action potential initiation	Increased action potential initiation	Increased action potential initiation
<b>D</b>	Decreased signal transduction efficiency	Increased action potential initiation	Increased action potential initiation	Delayed response to stimulus

[Turn Over

- 27 The ability of organisms to respond rapidly to stimuli is limited by the speed of the impulses in their neurons. The axons of invertebrate neurones lack a myelin sheath. The axons of most vertebrate neurons are myelinated. The graphs show the speed of impulses in these two types of axon.

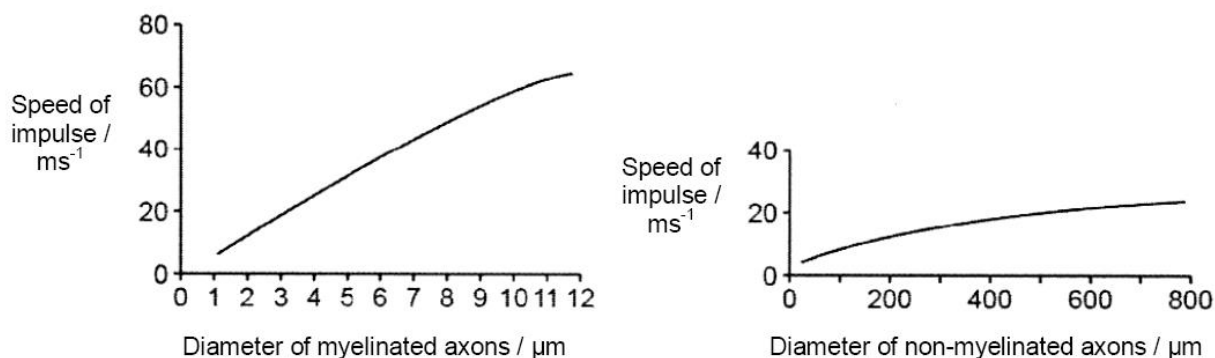

Which of the following statements are correct?

- 1 The action potential in myelinated axons is greater than the action potential in non-myelinated axons.
- 2 The speed of impulses is changed by the diameter of the axon.
- 3 Increasing the diameter of a myelinated axon causes a greater change in the speed of conduction than increasing the diameter of a non-myelinated axon.
- 4 The presence of myelin increases the speed at which impulses are conducted.

- A** 1, 2 and 3 only  
**B** 1, 2 and 4 only  
**C** 2, 3 and 4 only  
**D** 3 and 4 only

- 28 The graph shows the way in which blood glucose concentrations vary over part of a day for a person who does not have diabetes. The set point, indicated by a dotted line, is the blood glucose concentration that is maintained by homeostasis. During this time the person has two meals.

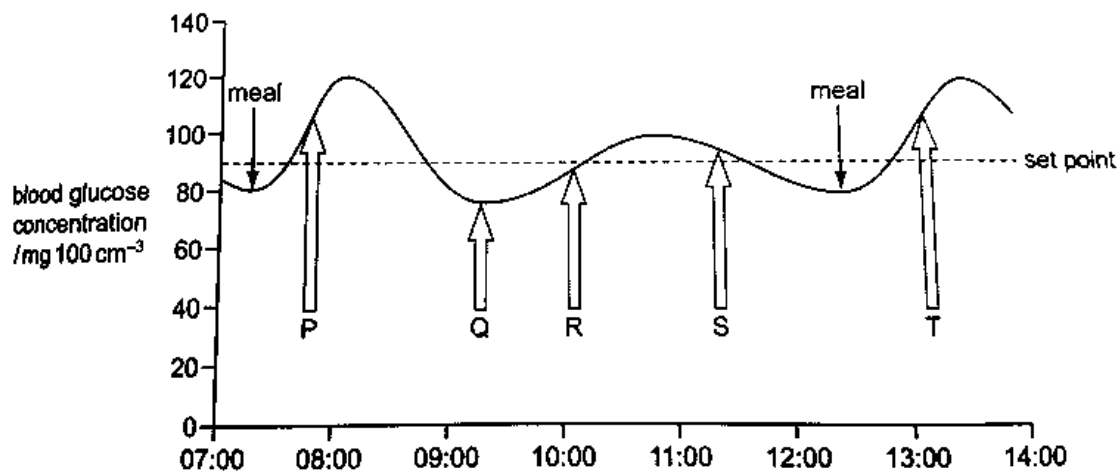

Which row correctly identifies times at which insulin secretion, glucose absorption from the small intestine and conversion of glucose to glycogen occur?

	Insulin secretion	Glucose absorption	Glucose converted to glycogen
<b>A</b>	P, S and T	P and T	P, S and T
<b>B</b>	P, R and T	P and T	S
<b>C</b>	P, S and T	P, R and T	Q and S
<b>D</b>	R and S	P, Q, R and T	P, Q, S and T

- 29 Which statements are acceptable parts of Darwinian evolutionary theory?

- 1 Advantageous behaviour acquired during the lifetime of an individual is likely to be inherited.
- 2 In competition for survival, the more aggressive animals are more likely to survive.
- 3 Species perfectly adapted to a stable environment will continue to evolve.
- 4 Variation between individuals of a species is essential for evolutionary change.

- A** 1, 2 and 4 only  
**B** 2 and 3 only  
**C** 3 and 4 only  
**D** 4 only

[Turn Over

- 30 The table shows the number of estimated nucleotide substitutions that have occurred since the divergence of seven species **a** to **g**.

	<b>b</b>	<b>c</b>	<b>d</b>	<b>e</b>	<b>f</b>	<b>g</b>
<b>a</b>	39	72	128	126	127	269
<b>b</b>		81	130	128	129	268
<b>c</b>			129	127	128	267
<b>d</b>				56	154	271
<b>e</b>					151	268
<b>f</b>						273

Which of the following phylogenetic trees best shows the relationship among these seven species?

**B**

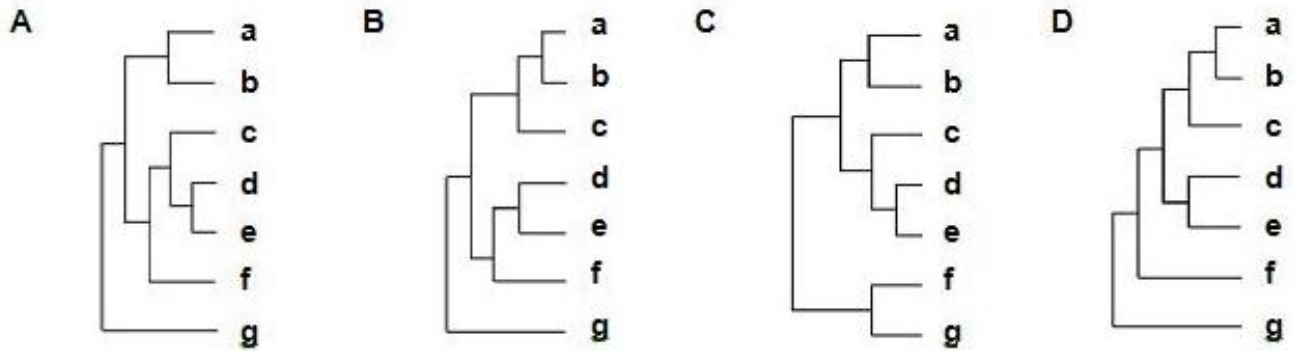



- 31 A scientist isolated and analysed the nucleotide sequence of the mtDNA of
- 994 modern humans
  - One Neanderthal fossil
  - Nine chimpanzees.

They compared these sequences. They were able to make human to human, Neanderthal to human and chimpanzee to human comparisons. The number of differences in the nucleotide sequence for each comparison was then recorded. The differences in mtDNA were quite small – no more than a few nucleotide bases – and relatively neutral in terms of evolution.

The results of these comparisons are shown in the graph below.

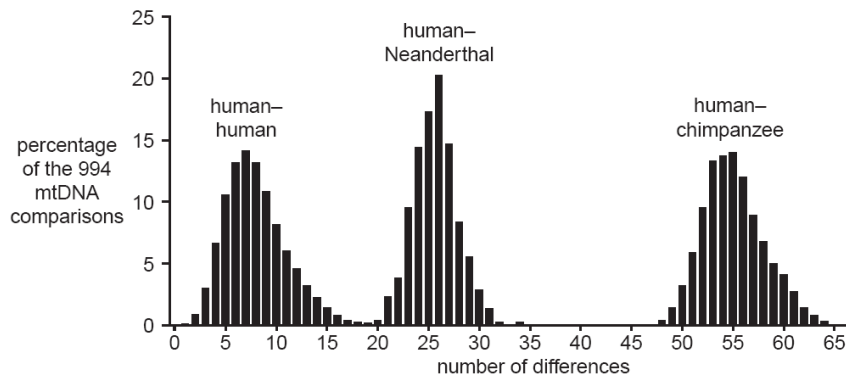

Which of the following statements is **not** true?

- A** This is an example of continuous variation.
- B** The difference between human mtDNA and that of the chimpanzees was greater than between Neanderthals and humans.
- C** Neanderthals are evolutionary closer to humans than to chimpanzees.
- D** The differences between the DNA of modern humans are much less than the differences between modern humans and Neanderthals.

[Turn Over

- 32 Figure below shows ending of neurone Y in the heart. Stimulation of Y leads to an increase in the concentration of the secondary messenger cyclic AMP (cAMP), in the cytoplasm of the heart cell.

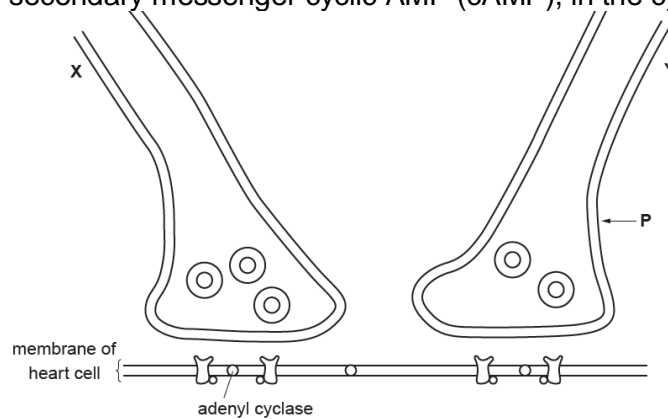

The stages involved in this cell signaling process include:

- 1 Vesicles fuse with post-synaptic membrane and exit via exocytosis and diffuse across the synaptic cleft.
- 2 Voltage-gated calcium channel opens leading to an influx of calcium ions into the neurone.
- 3 Adenylyl cyclase becomes activated and converts ATP to cAMP.
- 4 Calcium ions cause movement of neurotransmitter vesicles towards post-synaptic membrane (along microtubules).
- 5 Neurotransmitter binds to G protein coupled receptor on the membrane of heart cell and activates G protein.

What is the sequence of these stages?

- A 5 → 2 → 4 → 1 → 3  
 B 5 → 2 → 4 → 3 → 1  
 C 2 → 4 → 1 → 5 → 3  
 D 2 → 1 → 4 → 5 → 3

- 33 Chemical T is known to act on the cell signaling pathway of glucagon. It is found to diminish the effect of glucagon.

Which of the following is **not** a possible effect of Chemical T?

- A Chemical T interferes with release of glucagon from the pancreas.  
 B Chemical T activates the hydrolysis of GTP on the G protein.  
 C Chemical T inactivates the enzyme adenylyl cyclase.  
 D Chemical T act as a competitive inhibitor of the protein kinase.

- 34 The diagram below shows an autoradiograph, post-gel electrophoresis, showing the restriction fragments obtained from various members of a family with respect to a disease.

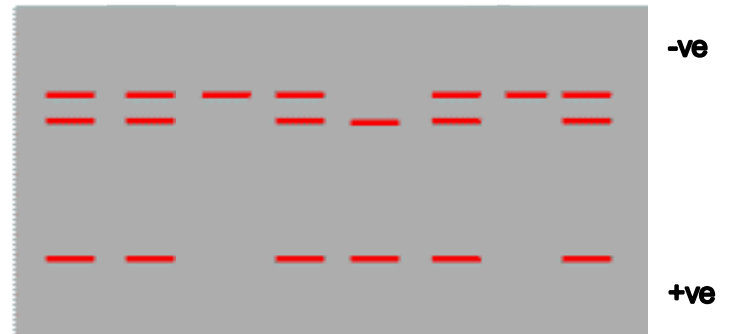
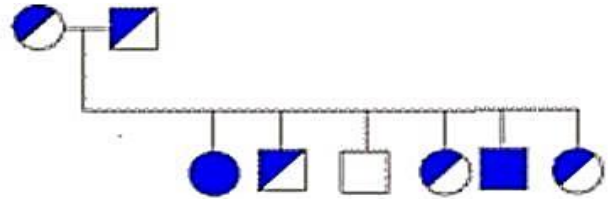
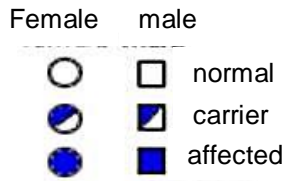

Which of the following statements can be concluded from this autoradiograph?

- 1 The recessive allele is missing a restriction site.
- 2 The disease is autosomal recessive.
- 3 The radioactive probe is able to bind to a specific sequence on the recessive allele only.

- A** 1 and 2  
**B** 2 and 3  
**C** 1 and 3  
**D** All of the above

[Turn Over

35 Plasmid X can serve as a vector for the insertion of genes to be cloned.

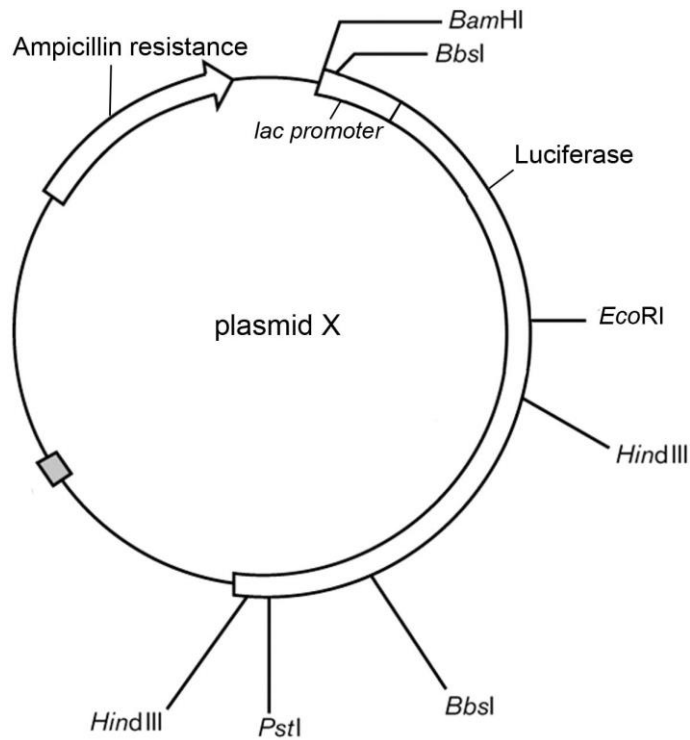

Which of the following options will allow the selection of the colonies containing the recombinant form of plasmid X?

	Selection medium	Phenotype of colonies that contain the inserted gene
<b>A</b>	Containing ampicillin and lactose	White colonies
<b>B</b>	Containing ampicillin and luciferase	Colonies that emit light
<b>C</b>	Containing ampicillin, lactose and luciferin	White colonies
<b>D</b>	Containing ampicillin, lactose and luciferin	Colonies that emit light

- 36 The dashed lines in the template sequence represent a long sequence of bases to be amplified.

Template

5' ATTCGGACTTG ----- GTCCAGCTAGAGG 3'

3' TAAGCCTGAAC ----- CAGGTCGATCTCC 5'

Which of the following sets of primers can be used in the PCR for the amplification of the following DNA sequence?

- A 3' TAAGCCT 5' & 5' CTAGAGG 3'
- B 5' ATTCGGA 3' & 3' GATCTCC 5'**
- C 3' UAAGCCU 5' & 5' CUAGAGG 3'
- D 5' AUUCGGA 3' & 3' GAUCUCC 5'
- 37 Cystic fibrosis (CF) is an autosomal recessive genetic disorder. An individual must have two copies of the mutated CFTR gene to express the disease phenotype. One of the most common CF-causing mutation resulted in a loss of phenylalanine located at position 508 of the protein.

The DNA sequence of the CF locus from the offspring of 2 carriers are removed and separated by gel electrophoresis.

Which pattern of bands corresponds to two of the offspring that are phenotypically normal?

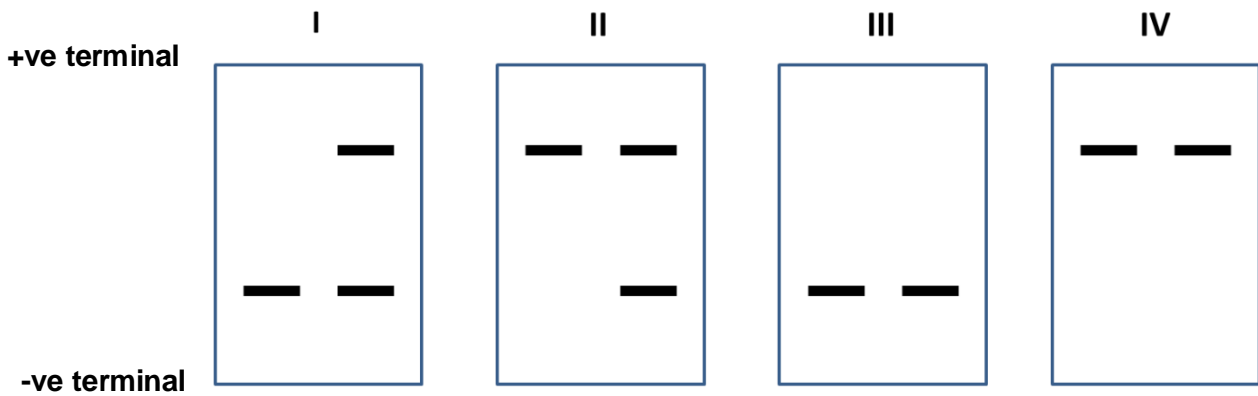

- A I only
- B II only
- C I and III**
- D II and IV

[Turn Over

- 38** The statements are about the preparation and application of DNA libraries.
- 1 A cDNA library allows the study of the functions of introns of specific genes
  - 2 A genomic library enables detection of genes that, in the host, have no detectable level of expression.
  - 3 Alternative splicing can be studied using a cDNA library
  - 4 The preparation of a genomic DNA library requires restriction enzyme, reverse transcriptase and DNA ligase

Which statements are correct?

- A** 1, 2 and 4
- B** 1 and 4 only
- C** 2, 3 and 4
- D** 2 and 3 only
- 39** Stem cells are found in many tissues that require frequent cell replacement such as the skin, the intestine or the blood.

However, within their own environments, a bone marrow cell cannot be induced to produce a skin cell and a skin cell cannot be induced to produce a bone marrow cell.

Which statement explains this?

- A** Different stem cells have only the genes required for their particular cell line.
- B** Genes not required for a particular cell line are methylated.
- C** Genes not required for a particular cell line are removed using restriction enzymes.
- D** mRNA that is not required for a particular cell line is destroyed.

**40** Gene therapy is used to treat inherited diseases such as cystic fibrosis. Some of the scientific and ethical concerns about gene therapy are listed below.

- 1 Most gene therapy must be repeated in succeeding generations since germ cells are not involved.
- 2 Genetically modified organisms used in producing the gene therapy may escape into the environment with unforeseen consequences.
- 3 Putting genes into the germ line affects subsequent generations and is banned in many countries.
- 4 The same techniques for treating serious, life-threatening conditions may be used to try to change other things such as intelligence and skin colour.
- 5 Viral vectors, such as those used in the treatment of cystic fibrosis, have been known to produce harmful side-effects.

Which row identifies the types of concern?

	Scientific concerns	ethical concerns
<b>A</b>	1 and 2	3, 4 and 5
<b>B</b>	2 and 4	1, 3 and 5
<b>C</b>	1 and 5	2, 3 and 4
<b>D</b>	3, 4 and 5	1 and 2

**BLANK PAGE**



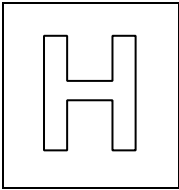

## JC2 Preliminary Examinations

In preparation for General Certificate of Education Advanced Level  
Higher 2

CANDIDATE  
NAME

--

CT  
GROUP

1	5	S	
---	---	---	--

INDEX  
NUMBER

--	--	--	--

## BIOLOGY

**9648/02**

Paper 2 Core Paper

**16 September 2016**

**2 hours**

Additional Materials: Writing Paper

### READ THESE INSTRUCTIONS FIRST

Write your name, CT class and index number on all the work you hand in.  
Write in dark blue or black pen.  
You may use a soft pencil for any diagrams, graph or rough working.  
Do not use paper clips, highlighters, glue or correction fluid.

#### Section A

Answer **all** questions.

#### Section B

Answer any **one** question.

All working for numerical answers must be shown.

The use of an approved scientific calculator is expected, where appropriate.

At the end of the examination, fasten all your work securely together in 2 separate section A and B.

The number of marks is given in brackets [ ] at the end of each question or part question.

For Examiner's Use	
<b>Section A</b>	<b>80</b>
<b>1</b>	
<b>2</b>	
<b>3</b>	
<b>4</b>	
<b>5</b>	
<b>6</b>	
<b>7</b>	
<b>8</b>	
<b>Section B</b>	<b>20</b>
<b>9 / 10</b>	
<b>Total</b>	

This document consists of **25** printed pages including the cover page and **1** blank page.

**[Turn Over**

## Section A

Answer **all** questions in this section.

- 1 Fig 1.1 shows some plant cells undergoing mitosis.

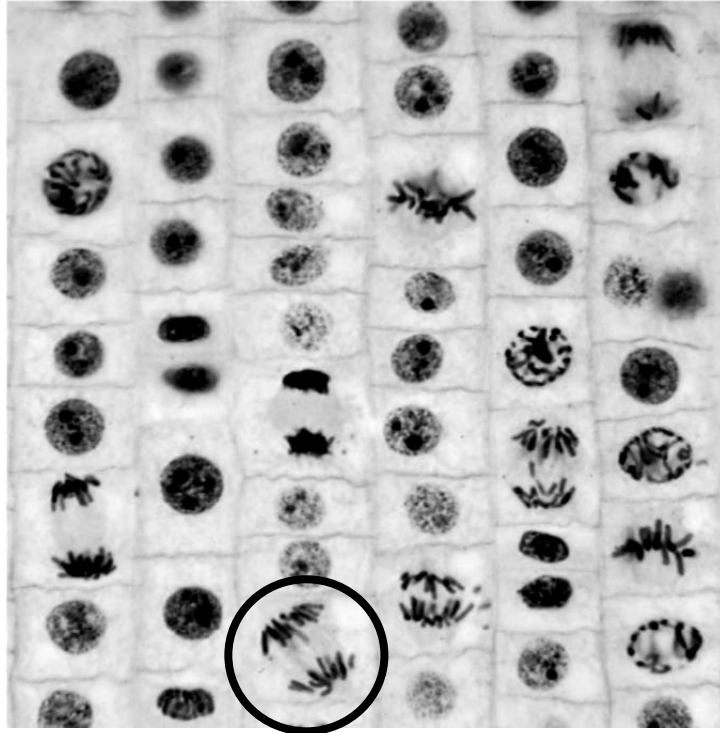

Fig. 1.1

Fig. 1.2 shows the changes in amount of DNA at different stages of the plant life cycle.

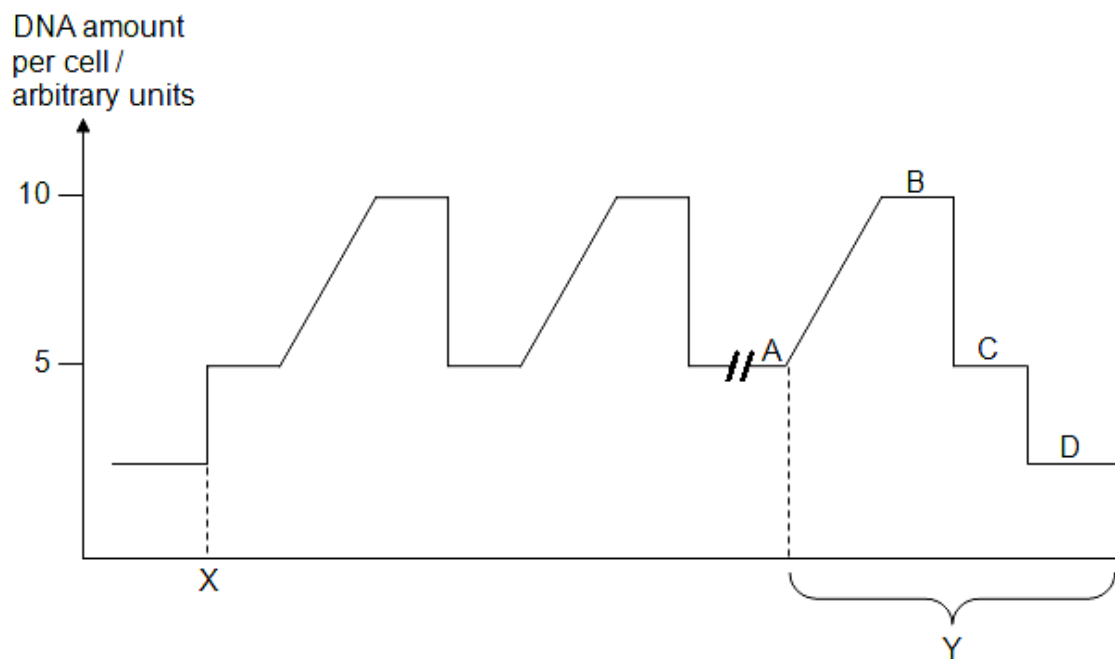

Fig. 1.2



2 Fig. 2.1 shows a bacterial cell during protein synthesis.

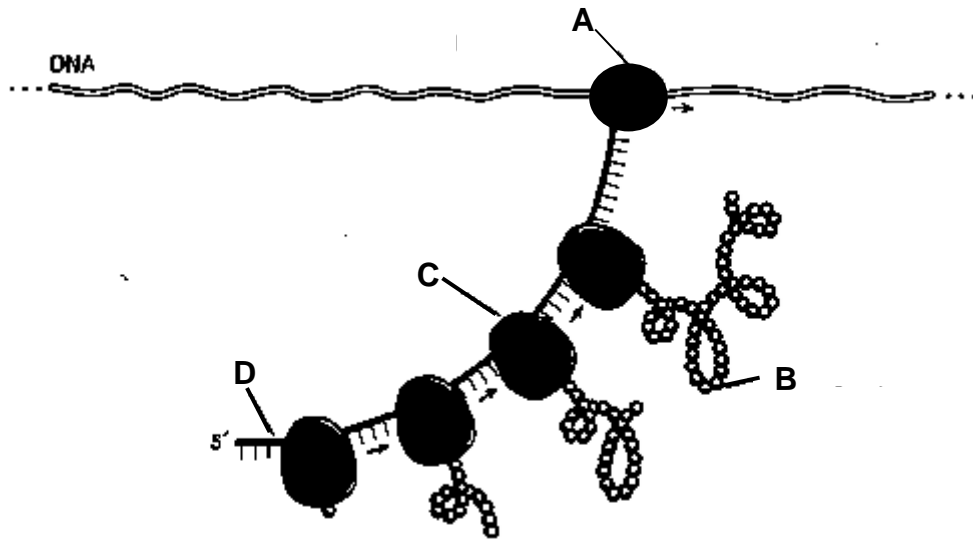

Fig. 2.1

(a) Identify A – D.

A .....

B .....

C .....

D ..... [2]

(b) With reference to Fig. 2.1, suggest evidences that indicate that these processes occurred in a prokaryotic cell.

.....  
 .....  
 ..... [1]

(c) Briefly describe how structure **A** differs from structure **C**.

.....  
.....  
.....  
.....  
..... [2]

(d) Activated tRNA can be seen entering structure **C**. Explain how the correct amino acid is joined to a tRNA.

.....  
.....  
.....  
.....  
.....  
.....  
.....  
.....  
.....  
..... [4]

[Total: 9]

[Turn Over

- 3 (a) Fig. 3.1 shows the viral load in the blood and CD4+ T cell counts over the course of a typical HIV infection.

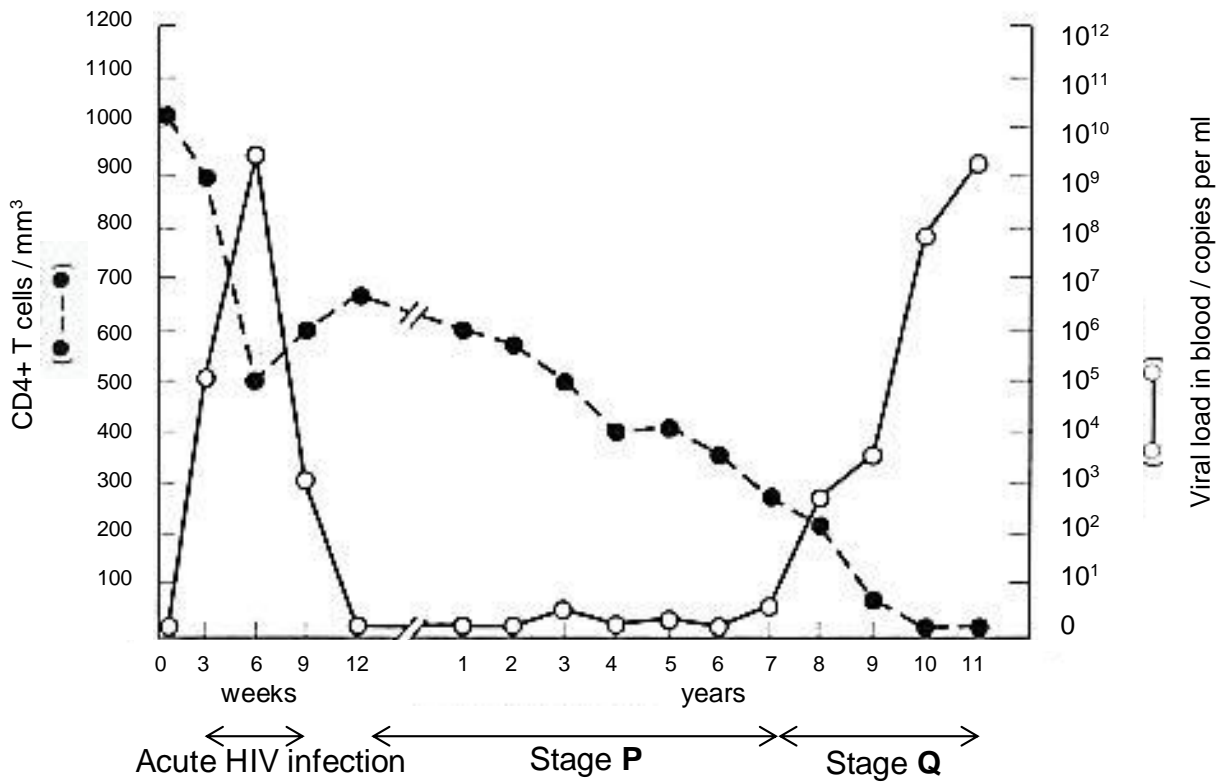

Fig. 3.1

- (i) Many cells in Stage P were found to contain viral DNA. Explain the significance of Stage P.

.....

.....

.....

.....

.....

..... [2]

(ii) In an experiment, it was found that the concentration of the enzyme, histone deacetylase (HDAC) in infected cells at Stage **P** was higher than in infected cells not at Stage **P**.

Suggest an explanation for the presence of abnormally high levels of HDAC in infected cells at Stage **P**.

.....  
.....  
.....  
.....  
..... [2]

(iii) With reference to Fig. 3.1, describe and explain the changes in the amount of HIV proteins and CD4+ T cells count during Stage **Q**.

.....  
.....  
.....  
.....  
..... [2]

(iv) Suggest how viral load may be measured in the blood.

.....  
.....  
..... [1]

**[Turn Over**

- (b) HIV enters a CD4+ T cell. Gp120 binds to CD4 receptor on host cell surface membrane. Gp120 undergoes conformational change enabling gp120 to bind to co-receptors CCR5 on host cell membrane. Interaction between gp120 and co-receptor brings about conformational change to gp41 on viral envelope leads to fusion of HIV envelope to the host cell surface membrane, gaining entry.

Fig. 3.2 shows a CCR5 co-receptor, which is a protein.

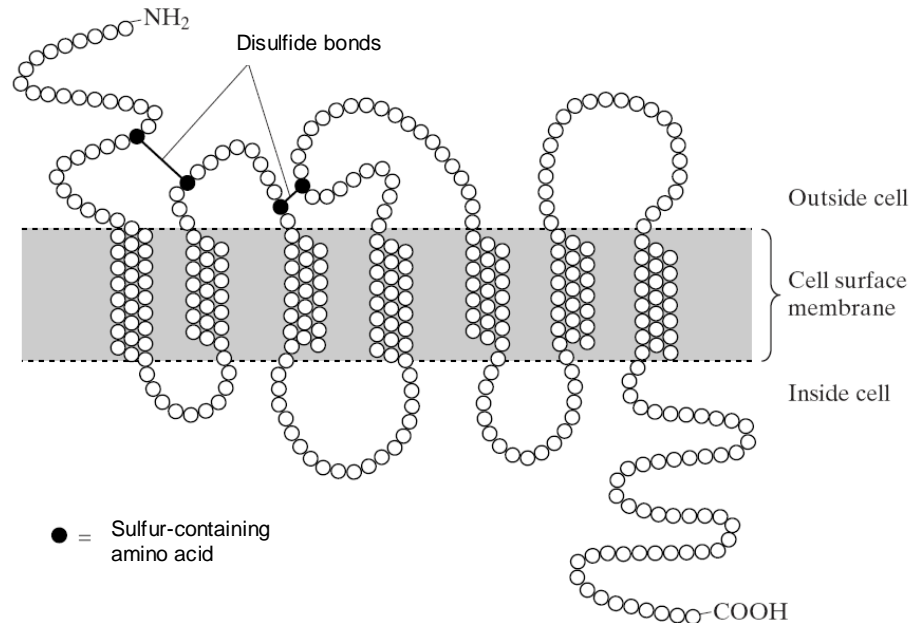

**Fig. 3.2**

Using information from Fig. 3.2, describe the protein structure of the CCR5 co-receptor.

.....

.....

.....

.....

..... [2]



(c) Integrase is one of the key targets for anti-retroviral therapy. An example of an anti-retroviral drug that acts on integrase is raltegravir. Fig. 3.3 shows the normal reaction catalysed by integrase, and Fig. 3.4 shows the effect of raltegravir on integrase.

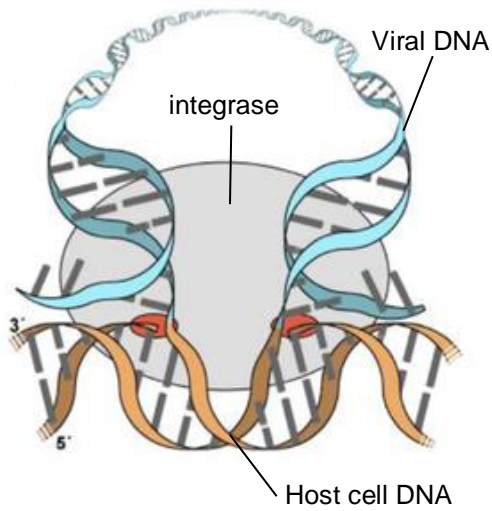

**Fig. 3.3**

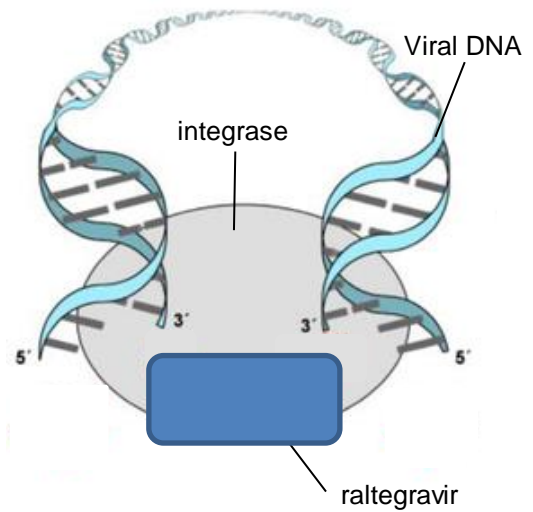

**Fig. 3.4**

Based on Fig. 3.3 and Fig. 3.4, describe the mode of action of raltegravir on integrase.

.....

.....

.....

.....

.....

..... [2]

[Total: 11]

[Turn Over

- 4 “Cancer is a disease of the genome, triggered by the accumulation of genetic errors that eventually transform a normal cell into a tumour cell. Such mutations might inactivate genes that normally oppose tumour development, or activate genes that drive cell growth or interfere with cell differentiation or death.

This leads to the 2 classes of genes which are responsible for cancer formation.”

*Nature* **417**, 906-907 (June 2002)

“Cancer is largely a disease of older people.”

*Nature Reviews Cancer* **5**, 655-662 (August 2005)

- (a) Using the above information, explain why cancer usually occurs in older individuals.

.....  
.....  
.....  
.....  
..... [2]

- (b) With specific named examples, distinguish between the 2 classes of genes stated in **line 5**.

.....  
.....  
.....  
.....  
.....  
.....  
.....  
..... [3]



(ii) describe how Ras may contribute towards the development of cancer.

.....

.....

.....

.....

.....

.....

.....

.....

.....

..... [3]

[Total: 12]

5 Fig. 5.1 shows the electron micrograph of a chloroplast with structures X, Y and Z labelled.

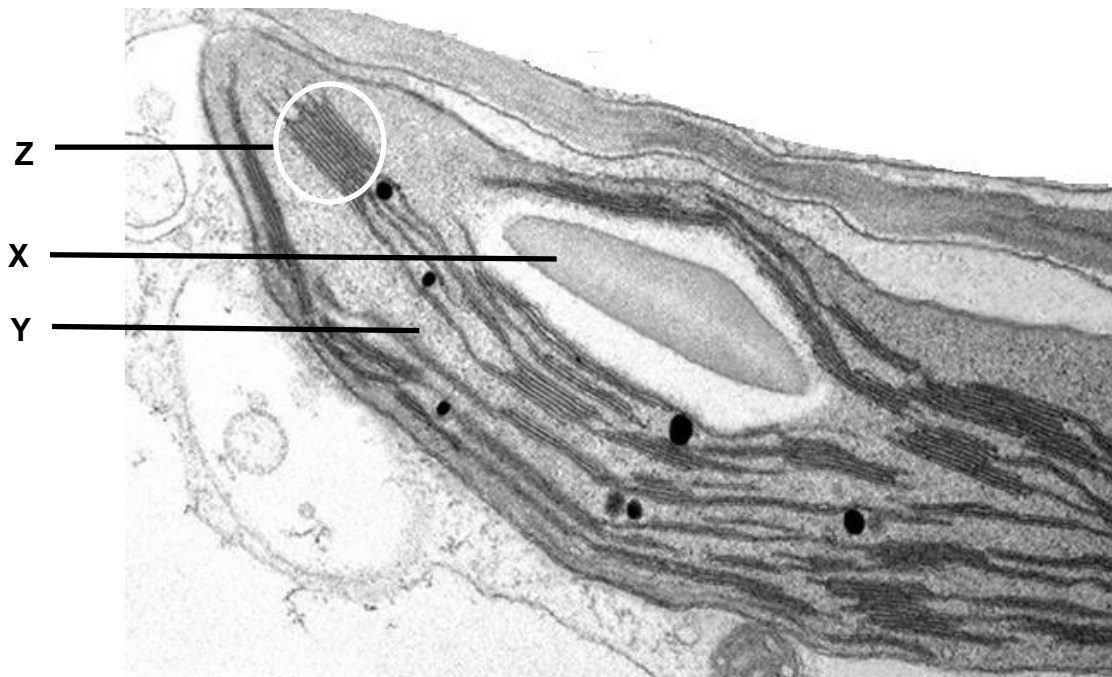

Fig. 5.1

(a) (i) Identify structures X and Y.

X .....

Y ..... [2]

(ii) Explain how Z is adapted to carry out photophosphorylation.

.....  
 .....  
 .....  
 .....  
 ..... [2]

[Turn Over

- (b) Rubisco is an important enzyme responsible for carbon fixation in the Calvin cycle. As Rubisco has an optimum pH of 9, it is most active during the daytime when the pH in the stroma is high.

Explain why Rubisco is most active during the daytime.

.....

.....

.....

.....

..... [2]

A process known as photorespiration also takes place in photosynthetic cells. In this process, oxygen competes with carbon dioxide for the active site of the enzyme Rubisco.

Fig. 5.2 outlines the process of photorespiration.

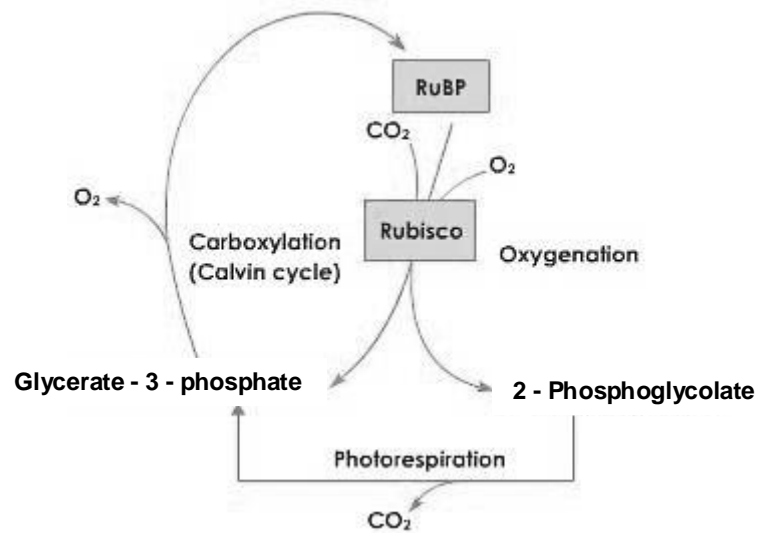

Fig. 5.2

- (c) (i) Describe and explain the effects of an increase in oxygen concentration on photosynthesis.

.....

.....

.....

.....

.....

.....

.....  
..... [3]

**(ii)** Suggest why the process outlined in Fig. 5.2 is known as photorespiration.

.....  
.....  
..... [1]

[Total: 10]

**[Turn Over**

- 6 An inbred variety of maize, **A**, with finely striped leaves was found to have high resistance to the fungus that causes the disease, corn leaf blight.

Plants of variety **A** were crossed with another inbred variety of maize, **B**, which had entirely green leaves and low resistance to the fungus. All the  $F_1$  generation had entirely green leaves and low resistance.

The above  $F_1$  generation was test crossed with variety **A** and yielded the following results:

finely striped leaves and high resistance	80
finely striped leaves and low resistance	20
entirely green leaves and high resistance	22
entirely green leaves and low resistance	78

- (a) A chi-squared test was performed on the results of the cross to determine if the results of the test cross depart significantly from the expected ratio. Calculate the  $\chi^2$  value using the formula provided below.

Formula for  $\chi^2$  calculation

$$\chi^2 = \sum \frac{(O-E)^2}{E} \quad v = c - 1$$

where  $\Sigma$  = 'sum of...'

$v$  = degrees of freedom

$c$  = number of classes

$O$  = observed 'value'

$E$  = expected 'value'

$\chi^2$  value: ..... [1]



**Table 6.1**

degree of freedom	probability, p				
	0.10	0.05	0.02	0.01	0.001
1	2.31	3.84	5.41	6.64	10.83
2	4.61	5.99	7.82	9.21	13.82
3	6.25	7.82	9.84	11.35	16.27
4	7.78	9.49	11.67	13.28	18.47

**(b)** Using Table 6.1, explain the conclusion drawn from the  $\chi^2$  test to determine if the observed numbers conformed to the expected.

.....

.....

.....

.....

.....

.....

.....

.....

..... [3]

**[Turn Over**

(c) Using the following symbols:

**G** entirely green leaf

**R** low resistance

**g**

finely striped leaf

**r**

high resistance;

Draw a genetic diagram to show the actual results of the test cross.

[4]

[Total: 8]

7 (a) Fig. 7.1 is an electron micrograph of a mitochondrion in a neurone.

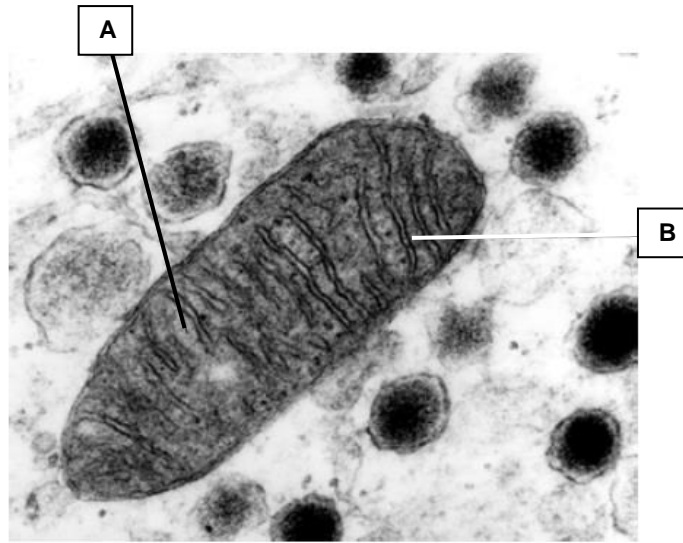

Fig. 7.1

Two stages of respiration occur in mitochondria. These are the Krebs cycle and oxidative phosphorylation.

(i) Complete the table below by naming the structures labelled **A** and **B** and stating which of the stages of respiration occur in each.

	Name of structure	Stage of respiration
<b>A</b>	..... .....	..... .....
<b>B</b>	..... .....	..... .....

[2]

[Turn Over



**(ii)** Explain how the release of the neurotransmitter, serotonin, results in the transmission of an impulse from neurone **A** to neurone **B**.

.....  
.....  
.....  
.....  
..... [2]

**(iii)** Suggest why nerve impulse can only travel in one direction across a synapse.

.....  
.....  
..... [1]

[Total: 10]

**[Turn Over**



(b) Suggest the role of the islands in the evolution of thirteen species of Darwin finches now found on the Galapagos Islands.

.....

.....

.....

.....

..... [2]

Molecular analysis was carried out on the mitochondrial DNA (mtDNA) sequences of the Galapagos Islands finches and the Cocos finch found on the island of Cocos, 830 km to north-east of the Galapagos Islands. Using mtDNA analysis data, a map showing the phylogeny of these finches was constructed as shown below in Fig. 8.2.

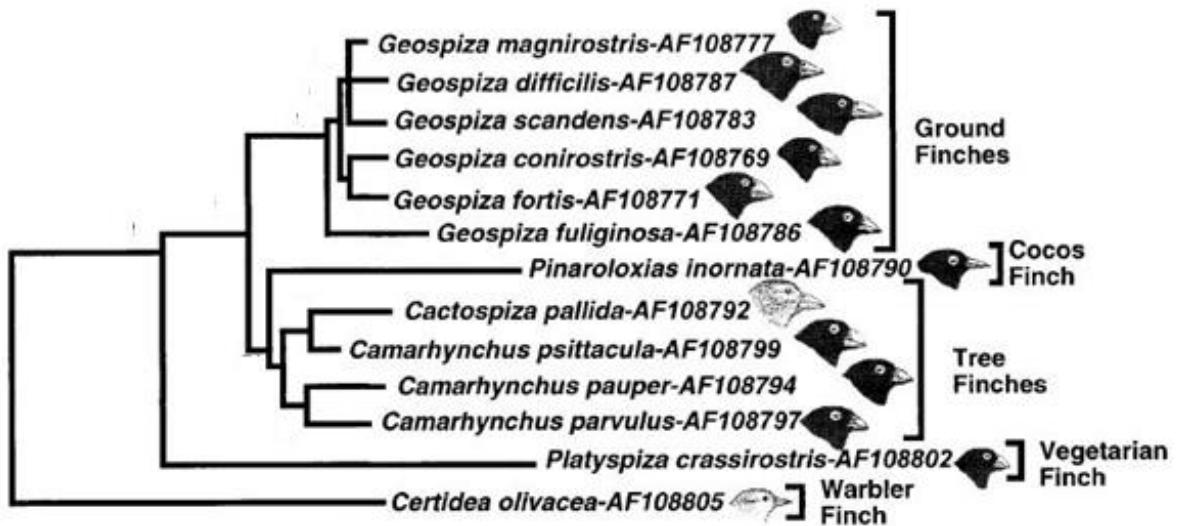

Fig. 8.2

(c) Explain how DNA sequences can be used to determine evolutionary relatedness between species.

.....

.....

.....

.....

..... [2]

[Turn Over

(d) Describe the advantages of using nucleotide data such as mtDNA in classifying organisms.

.....

.....

.....

.....

..... [2]

Differences in the *cytochrome b* DNA sequence of several finches' species from Galapagos Islands and island of Cocos were measured and plotted against time since divergence from the primitive ancestor (MYA) as seen in Fig. 8.3.

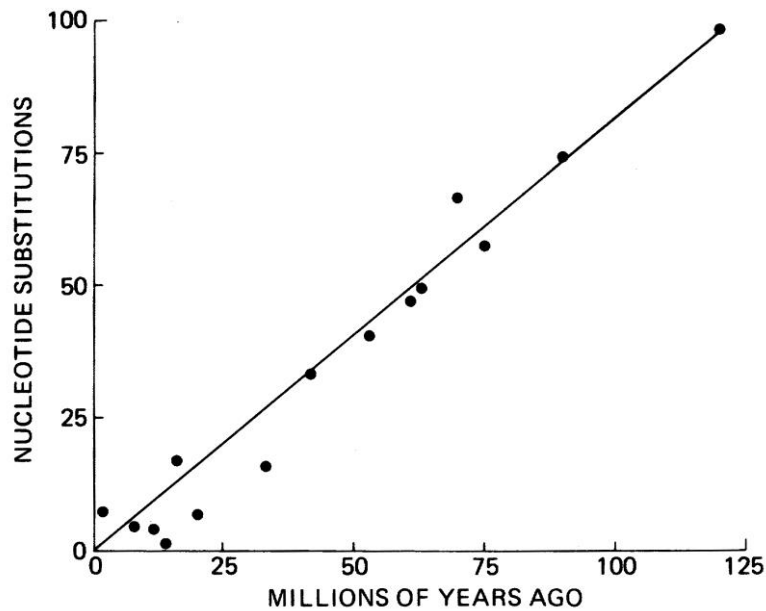

Fig 8.3

(e) Describe how these differences support the neutral theory of molecular evolution.

.....

.....

.....

.....

..... [2]

[Total: 12]



**Section B**

Answer **one** question.

Write your answers to this question on the separate answer paper provided.

Your answers should be illustrated by large, clearly labelled diagrams, where appropriate.

Your answers must be in continuous prose, where appropriate.

Your answers must be set out in sections **(a)**, **(b)** etc., as indicated in the question.

- 9 (a)** Compare and contrast between glucagon and glycogen. [4]
- (b)** Explain what is meant by primary, secondary, tertiary, and quaternary structure of a named protein. [8]
- (c)** Describe the main properties of an enzyme and discuss their mode of action. [8]

[Total: 20]

- 10 (a)** With reference to the islets of Langerhans, describe what is meant by an endocrine gland. [7]
- (b)** Explain how the blood glucose concentration is regulated by insulin and glucagon. [8]
- (c)** Describe how the endocrine system differs from the nervous system. [5]

[Total: 20]

**[Turn Over**

**BLANK PAGE**

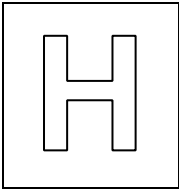

## JC2 Preliminary Examinations

In preparation for General Certificate of Education Advanced Level  
Higher 2

CANDIDATE  
NAME

CT  
GROUP

1	5	S		
---	---	---	--	--

INDEX  
NUMBER

--	--	--	--

## BIOLOGY

**9648/02**

**16 September 2016**

Paper 2 Core Paper

**2 hours**

Additional Materials: Writing Paper

### READ THESE INSTRUCTIONS FIRST

Write your name, CT class and index number on all the work you hand in.  
Write in dark blue or black pen.  
You may use a soft pencil for any diagrams, graph or rough working.  
Do not use paper clips, highlighters, glue or correction fluid.

#### Section A

Answer **all** questions.

#### Section B

Answer any **one** question.

All working for numerical answers must be shown.

The use of an approved scientific calculator is expected, where appropriate.

At the end of the examination, fasten all your work securely together in 2 separate section A and B.

The number of marks is given in brackets [ ] at the end of each question or part question.

For Examiner's Use	
<b>Section A</b>	<b>80</b>
1	
2	
3	
4	
5	
6	
7	
8	
<b>Section B</b>	<b>20</b>
9 / 10	
<b>Total</b>	

This document consists of **26** printed pages including the cover page.

**[Turn Over**

## Section A

Answer **all** questions in this section.

- 1 Fig 1.1 shows some plant cells undergoing mitosis.

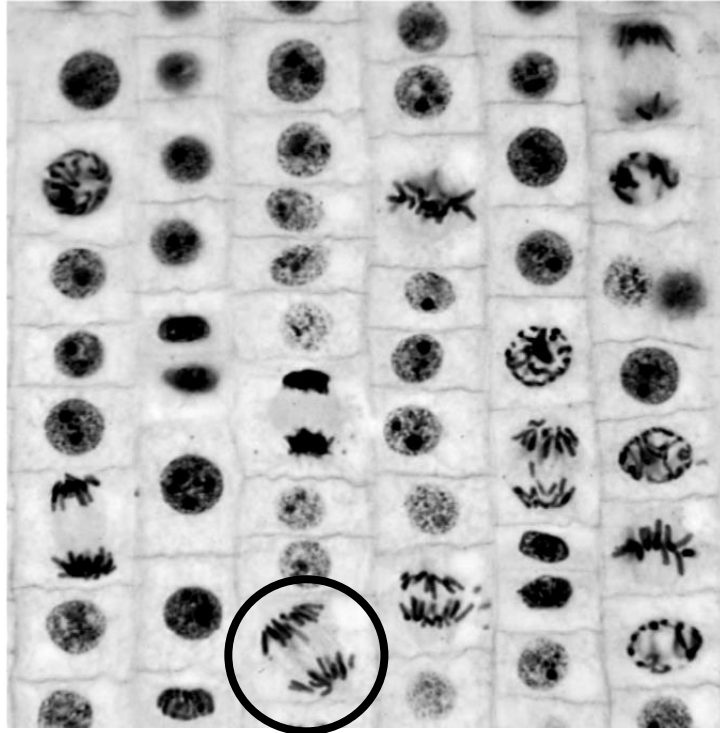

Fig. 1.1

Fig. 1.2 shows the changes in amount of DNA at different stages of the plant life cycle.

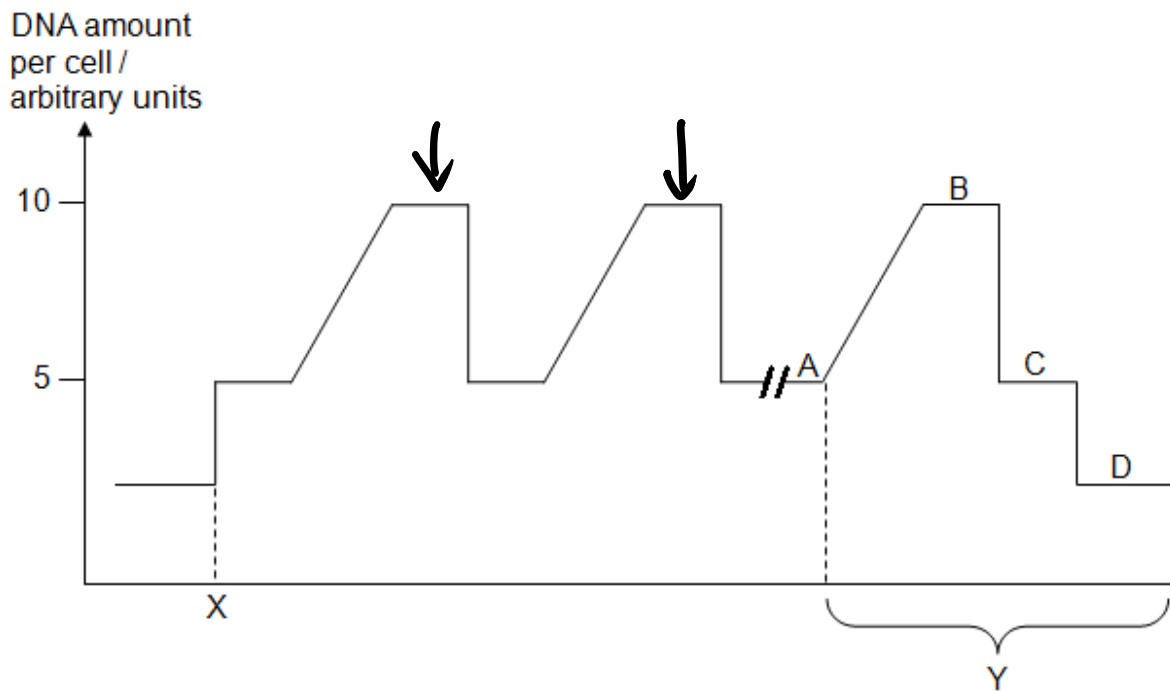

Fig. 1.2

- (a) Mark out with an arrow ↓ clearly on Fig 1.2 which part of the graph corresponds to the stage circled in Fig. 1.1. [1]

**Accept all part of line except the corners (accept one arrow on either plateau, but not on the Meiosis plateau)**

- (b) From stages **A** to **D** in Fig. 1.2, state all stages

- (i) that has/have the same number of chromosomes as shown in Fig. 1.1; [1]

**A and B;;**

- (ii) that has/have the **different** number of chromosomes as shown in Fig. 1.1; [1]

**C and D;;**

- (c) Explain the significance of the stages in **Y** in genetic variation. [4]

- a) Crossing over between non-sister chromatids of homologous chromosomes/bivalents/homologous pair takes place during prophase I;;  
OR  
where equivalent portions of non-sister chromatids of homologous chromosomes break and rejoin during prophase I;;

- b) gives rise to new combination of alleles / mixing of alleles from both parental chromosomes which creates genetic variation in gametes;;  
A: new linkage groups in place of new combination of alleles

- c) Independent assortment of homologous chromosomes/bivalents/homologous pair at metaphase plate during metaphase I and their subsequent separation during anaphase I;;  
OR  
Homologous chromosomes are arranged independently of other homologous pairs at metaphase plate during metaphase I and their subsequent separation during anaphase I;;

- d) results in  $2^n$  possible (types of ) gametes where n is the number of homologous pairs;;  
OR  
Gametes with different combinations of parental (maternal and paternal) chromosomes;;

- (d) Explain the significance of the event occurring at **X**. [1]

- a) X refers to fertilisation\*; Or random fusion of gametes\* results in  
b) greater variation/varied offspring with different genotypes and phenotypes;  
OR  
Restoration of the diploid number of chromosomes;

[Total: 8]

[Turn Over

2 Fig. 2.1 shows a bacterial cell during protein synthesis.

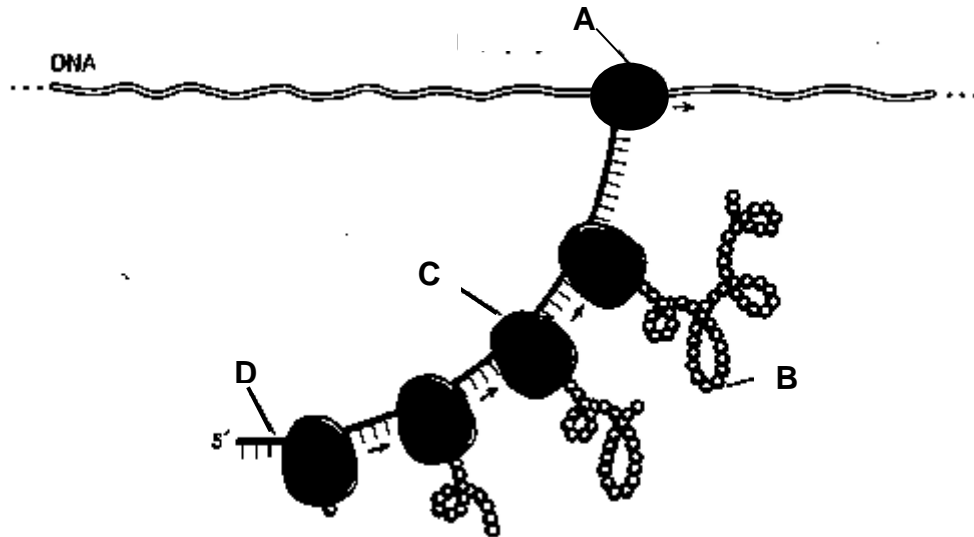

(a) Identify A – D. [2]

**A - RNA polymerase**  
**B- growing polypeptide chain**  
**C - ribosome**  
**D - mRNA**

(b) With reference to Fig. 2.1, suggest evidences that indicate that these processes occurred in a prokaryotic cell. [1]

- a) **Presence of polyribosomes/ polysomes;**
  - b) **Transcription and translation occur simultaneously;**
  - c) **No membrane separates transcription and translation; (OWTTE).**
- Any 2

(c) Briefly describe how structure A differs from structure C.[2]

**Structure C is ribosome, Structure A is RNA polymerase**

- a) **Ribosome composed of ribosomal RNA and proteins while RNA polymerase is a protein made up of amino acids;;**
- b) **RNA polymerase is single unit while ribosome consists of 2 subunits (1 large and 1 small ribosomal subunit);;**
- c) **Ribosomes have 3 binding sites (APE) while RNA polymerase has 1 active site present;;**

(d) Activated tRNA can be seen entering structure C. Explain how the correct amino acid is joined to a tRNA. [4]

- The process that joins the correct amino acid to the tRNA is known as amino acid activation.
- Attachment of amino acid to a specific tRNA is catalysed by an enzyme called aminoacyl tRNA synthetase
- These enzymes have active sites which will recognize and fit only a specific combination of amino acid and anticodon of a tRNA that are complementary to the active sites
- As there are 20 commonly found amino acids, there will be at least 20 different aminoacyl tRNA synthetases.
- The synthetase enzyme catalyses the covalent attachment of the amino acid to its tRNA
- In a energy releasing process driven by hydrolysis of ATP.
- The resulting aminoacyl tRNA complex is released from the enzyme and will deliver its amino acid to the growing polypeptide chain on a ribosome.
- ensures that correct amino acid as specified by the genetic code is matched to the correct tRNAs

[Total: 9]

3 (a) Fig. 3.1 shows the viral load in the blood and CD4 T cell counts over the course of a typical HIV infection.

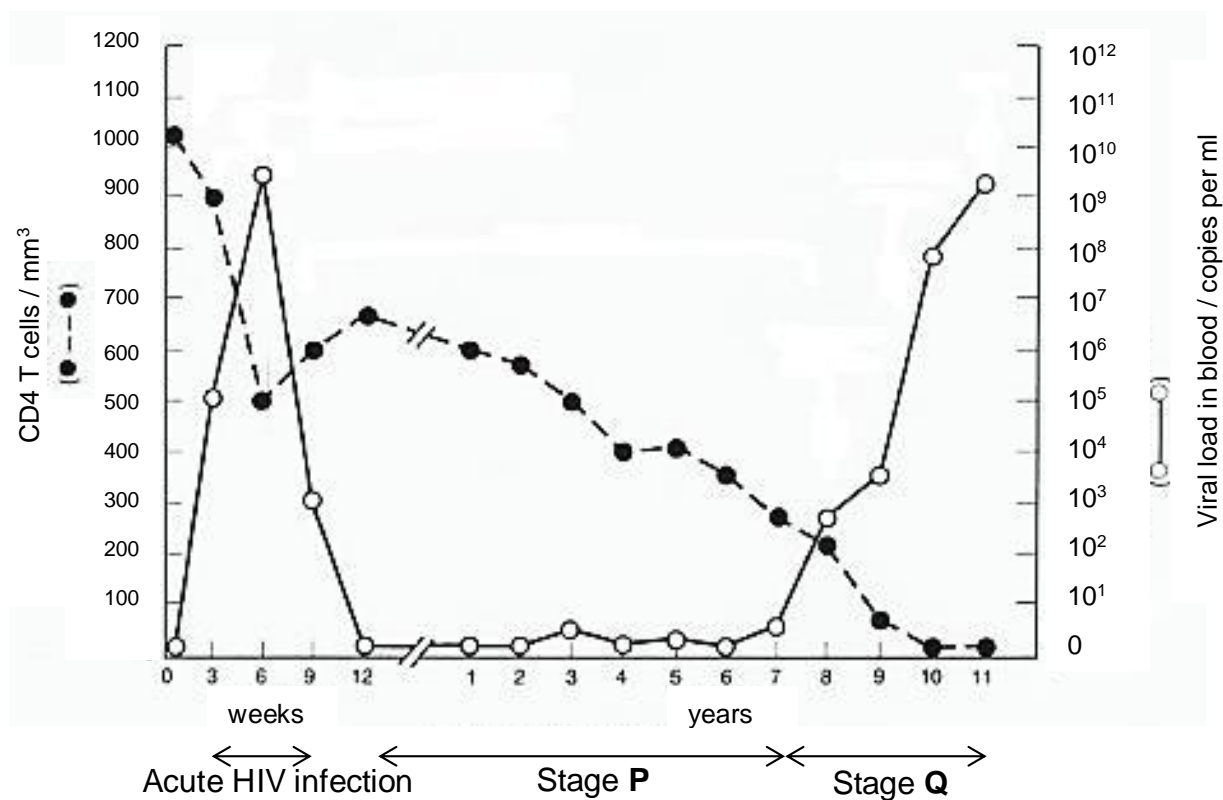

Fig. 3.1

(i) Many cells in Stage **P** were found to contain viral DNA. Explain the significance of Stage **P**. [2]

- a) Double stranded DNA reverse transcribed from the viral RNA ;
- b) integrates into the host cell DNA via integrase ;
- c) So that the viral DNA (encoding viral proteins) can replicate along together with the host cell DNA;
- d) Idea of results in production of more virions that carries the viral DNA ( hence more viral progeny can be produced upon activation of the host cells) ;

(ii) In an experiment, it was found that the concentration of the enzyme, histone deacetylase (HDAC) in infected cells at Stage **P** was higher than in infected cells not at Stage **P**.

Suggest an explanation for the presence of abnormally high levels of HDAC in infected cells at Stage **P**. [2]

- a) Deacetylation of lysine residues in histone tails become positively charged
- b) results in increased affinity of the histone complex for the DNA molecule. Histone deacetylase cause chromatin to be more condensed / compacted/ packed more tighter
- c) Prevents transcription and translation of viral proteins during stage P
- d) Viral proteins not present on infected cells → not detected and destroyed by immune system;

(iii) With reference to Fig. 3.1, describe and explain the changes in the amount of HIV proteins and CD4+ T-cells count during Stage **Q**. [2]

- a) From 7 to 11 years after infection, viral proteins increases from 5 copies per ml to  $10^9/10^{10}$  copies per ml because viral proteins are actively transcribed from integrated HIV DNA/provirus to form new viruses;;
- b) CD4 T cells decrease from 300 cells per  $\text{mm}^3$  to 10 cells per  $\text{mm}^3$  as budding of large amount of virions from the cell surface of CD4 T cells may disrupt the cell membrane sufficiently for cell to die / Hijacking of cellular machinery and resources towards producing new virions disrupts normal activities needed for cell survival, eventually causing cell death.;;

(iv) Suggest how viral load may be measured in the blood. [1]

- a) Via detection of HIV RNA in blood sample;; OR
- b) Via detection of viral proteins ;;

(b) HIV enters a CD4 cell. Gp120 binds to CD4 receptor on host cell surface membrane. Gp120 undergoes conformational change enabling gp120 to bind to co-receptors CCR5 on host cell membrane. Interaction between gp120 and co-receptor brings about conformational change to gp41 on viral envelop leads to fusion of HIV envelope to the host cell surface membrane, gaining entry.

Fig. 3.2 shows a CCR5 co-receptor, which is a protein.



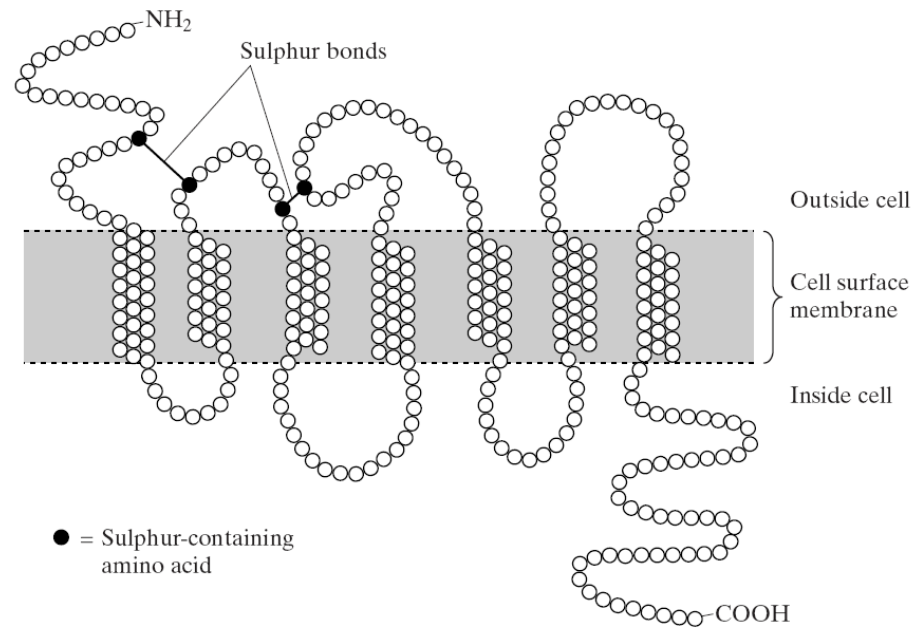
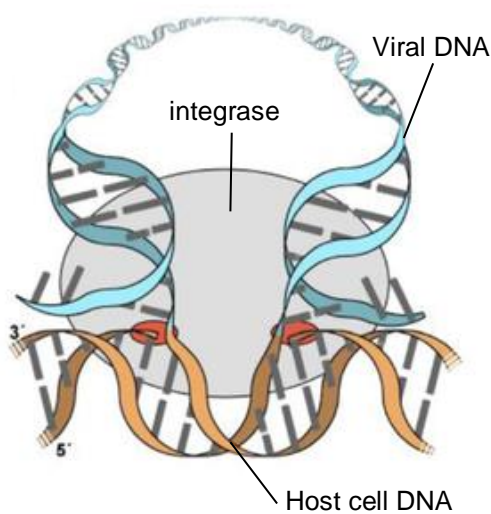

**Fig. 3.2**

Using information from Fig. 3.2, describe the protein structure of the CCR5 co-receptor. [2]

- a) **Primary Structure – sequence of amino acid in polypeptide chain;**
- b) **Secondary structure consist of folding/helix in membrane involving mainly H-bonds between carbonyl and amino group;**
- c) **Tertiary structure – Loops outside membrane and involves R group interactions;**
- d) **Role of disulphide bonds present to maintain the tertiary structure of the protein;**

- (c) Integrase is one of the key targets for anti-retroviral therapy. An example of an anti-retroviral drug that acts on integrase is raltegravir. Fig. 3.3 shows the normal reaction catalysed by integrase, and Fig. 3.4 shows the effect of raltegravir on integrase.



**Fig. 3.3**

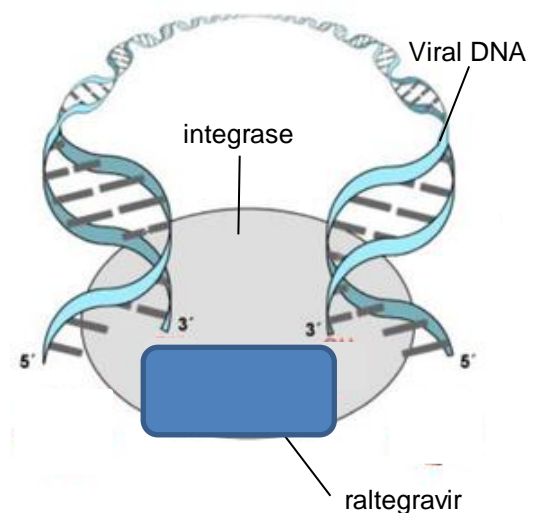

**Fig. 3.4**

Based on Fig. 3.3 and Fig. 3.4, describe the mode of action of raltegravir on integrase. [2]

- a) Raltegravir is a competitive inhibitor;
- b) It binds to the active site of integrase;
- c) Prevents integrase from binding to dsDNA;
- d) double stranded DNA will not be incorporated into the host cell's DNA as a provirus (by integrase);

[Total: 11]

- 4 “Cancer is a disease of the genome, triggered by the accumulation of genetic errors that eventually transform a normal cell into a tumour cell. Such mutations might inactivate genes that normally oppose tumour development, or activate genes that drive cell growth or interfere with cell differentiation or death.

This leads to the 2 classes of genes which are responsible for cancer formation.”

*Nature* 417, 906-907 (June 2002)

“Cancer is largely a disease of older people.”

*Nature Reviews Cancer* 5, 655-662 (August 2005)

- (a) Using the above information, explain why cancer usually occurs in older individuals [2]

- a) a single mutation in the cell is not enough to cause the cell to be cancerous as cancer development is a multi-step process;
- b) Time is required to accumulate mutations in many genes in the same cell for it to become fully cancerous;
- c) Older individuals are exposed longer to mutagens over their lifetime;
- d) Increasing the chance/probability of mutations occurring;

- (b) With specific named examples, distinguish between the 2 classes of genes stated in **line 5**. [3]

1 mark for both correct named examples  
Any 2 differences

	Proto-oncogene (e.g. Ras gene)	Tumor Suppressor Gene (e.g. p53)
a) Primary function of gene product	<u>stimulate normal cell division</u>	<u>prevent uncontrolled cell division</u>
b) How does it attribute to the occurrence of cancer?	<u>Over-activation (turn on) of proto-oncogenes → oncogene → occurrence of cancer</u>	<u>Inactivation (turn off) of TSG → occurrence of cancer</u>
c) Type of mutation and its consequence	<u>Gain of function mutation → increase in the amount of gene product/ increase in the intrinsic activity of the gene product</u>  <u>A mutation in only one allele of</u>	<u>Loss of function mutation → decrease in the amount/elimination of gene product, decrease in the activity of the gene products</u>  <u>Mutations in both alleles of a</u>

	<b>a proto-oncogene, converting to an oncogene, is needed for the cell to lose growth control</b>	<b>TSG are needed for the cell to lose growth control.</b>
<b>d) Is inheritance involved?</b>	<b>Majority of oncogenes develop from mutations in normal genes (proto-oncogenes) during the life of the individual</b>  <b>→somatic mutations</b>	<b>Abnormalities of tumor suppressor genes can be <u>inherited</u> as well as <u>acquired</u> during the life of the individual.</b>  <b>→Germline and somatic mutation.</b>

Fig. 4.1 illustrates the RAS–BRAf–MAPK (mitogen-activated protein kinase) signalling pathway, to control cell proliferation or differentiation by changes in gene expression. Signal-transduction genes such as Braf and those of the Ras family, which encode components of the MAPK pathway, are frequently mutated in cancers.

Extracellular signals (growth factors) that activate one of two types of receptor — receptor tyrosine kinases and G-protein-coupled receptors — can result in the activation of Ras, leading to activation of Braf and the downstream cascade

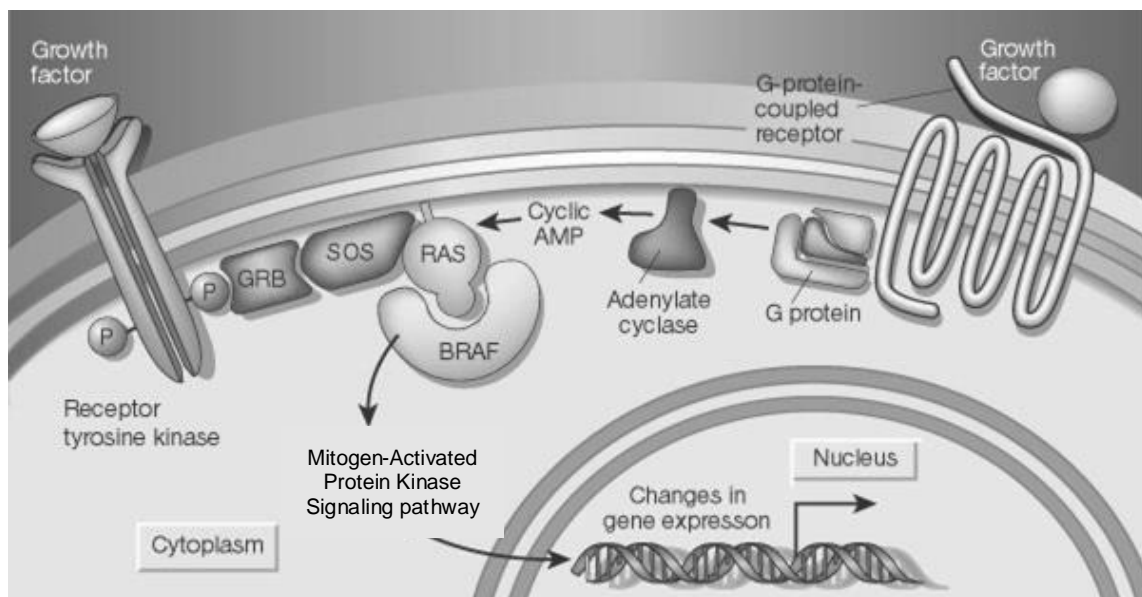

**Fig. 4.1**

**(c)** With reference to Fig. 4.1,

(i) Describe how Ras protein can be activated by **one** of the growth factors. [4]

- Growth factor (ligand) binds to G-protein-coupled receptors, receptor undergoes change in conformation which binds to inactive G-protein;;**
- Causes a GTP to displace GDP on the G protein, activating it;;**
- Activated G protein binds to adenylate cyclase, activating it;;**
- Activated adenylate cyclase will catalyse the formation of cAMP from ATP, cAMP will trigger activation of Ras protein;;**

**OR**

- e) Binding of growth factor causes two receptor polypeptides to associate, forming a dimer;;
- f) Dimerisation activates the tyrosine kinase parts of both polypeptides → each add phosphates to tyrosines on the tail of the other polypeptide/resulting in autophosphorylation of the tyrosines on the tail of the other polypeptide;;
- g) Activated tyrosine kinase is recognised by relay protein GRB which binds to phosphorylated tyrosine and undergoes structural change that activates it;;
- h) Activated GRB will in turn allow SOS to bind and be activated, which will in turn bind to Ras protein and activate it;;

(ii) Describe how Ras may contribute towards the development of cancer. [3]

- a) Single point-mutation of the Ras proto-oncogene could potentially lead to the production of a hyperactive Ras protein which is active even when growth factors are absent;;
- b) Leading to an overactivation of Braf protein which could then overstimulate the mitogen-activated protein kinase signalling pathway;;
- c) This may then lead to an increase in gene expression of growth factors/proteins which stimulate cell proliferation;;

[Total: 12]

- 5 Fig. 5.1 shows the electron micrograph of a chloroplast with structures X, Y and Z labelled.

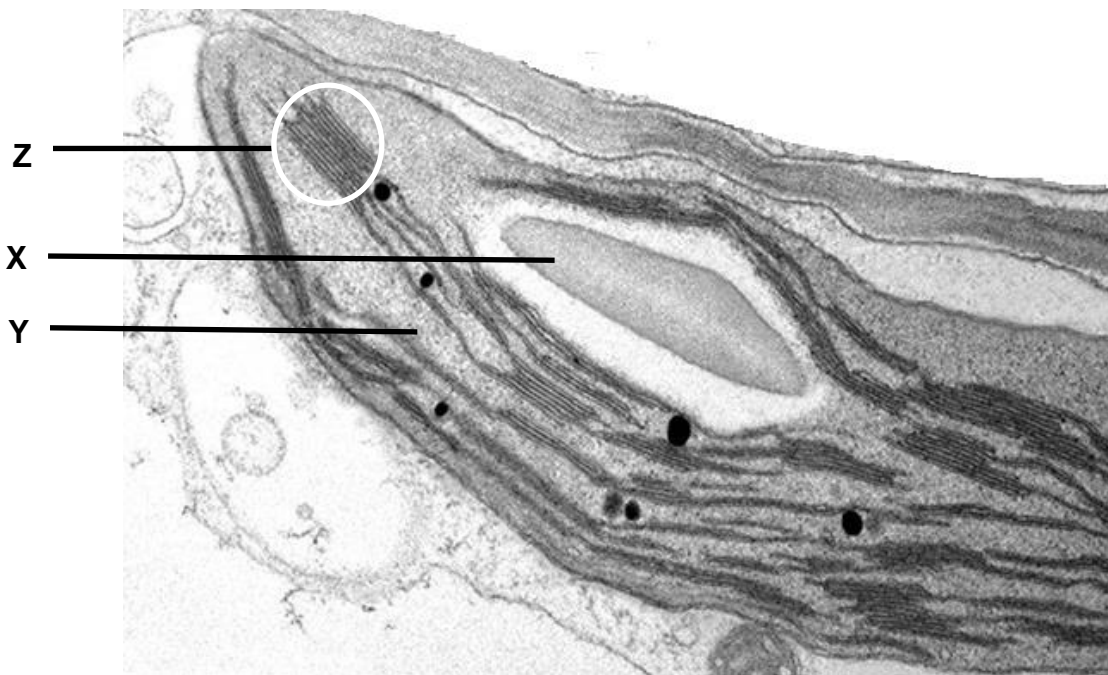

Fig. 5.1

- (a) (i) Identify structures X and Y. [2]

**X : Starch grain/granule**

**Y : stroma**

- (ii) Explain how the Z is adapted to carry out photophosphorylation. [2]

**a. Z, is made from a stack of thylakoid membranes, / provides a large surface area;;**

- b. Allows for embedding of many photosynthetic pigments / photosystems / light harvesting complexes, for light, harvesting / absorption;;
- c. The thylakoid membrane is impermeable to  $H^+$  thus protons can only diffuse through stalked particles embedded in the membrane down its concentration gradient;;

(b) Rubisco is an important enzyme responsible for carbon fixation in the Calvin cycle. As Rubisco has an optimum pH of 9, it is most active during the daytime when the pH in the stroma is high.

Explain why Rubisco is most active during the daytime. [2]

- a. In the daytime, presence of light cause photophosphorylation to occur;;
- b. energy released from ETC is used to pump  $H^+$  / actively transport  $H^+$  from stroma into thylakoid space;;
- c. (low  $H^+$  concentration in the stroma)→ reference to active site: the contact residues and/or catalytic residues in the active site are of the correct charge to bind the substrate molecules and catalyse the reaction respectively;;
- d. OR Ionic bonds between R-groups are stabilized confirmation of active site (most complementary to substrate
- e.

A process known as photorespiration also takes place in photosynthetic cells. In this process, oxygen competes with carbon dioxide for the active site of the enzyme Rubisco.

Fig. 5.2 outlines the process of photorespiration.

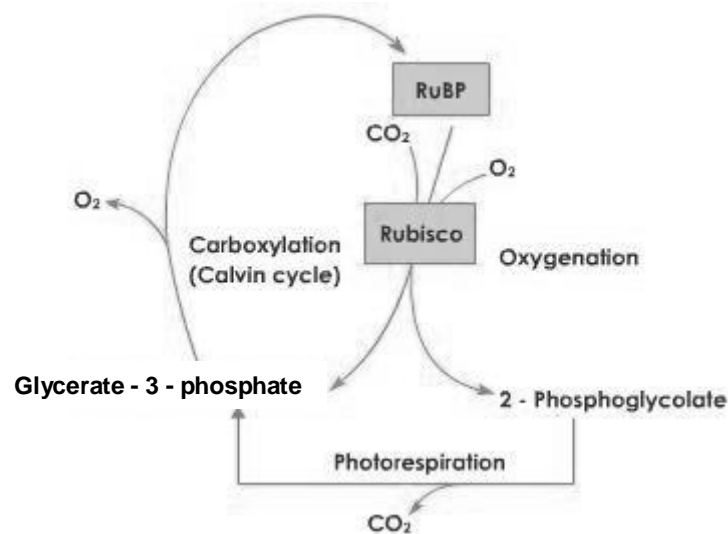

Fig. 5.2

(c) (i) Describe and explain the effects of an increase in oxygen concentration on photosynthesis. [3]

- a. An increase in oxygen concentration reduces the rate of photosynthesis / increases the rate of photorespiration;;
- b. This is less Rubisco is available for CO<sub>2</sub> / more oxygen competing with CO<sub>2</sub> for Rubisco;;
- c. This results in less CO<sub>2</sub>, fixation for Calvin cycle;;
- d. There is less, glycerate-3-phosphate, produced and less RuBP being, regenerated ;;

(iii) Suggest why the process outlined in Fig. 5.2 is known as photorespiration. [1]

- The process uses oxygen and, excretes / produces , carbon dioxide;
- Light energy / non-cyclic photophosphorylation / light dependent reaction / products of the light dependent reaction / ATP and NADPH, is required for this process to occur;
- The same photosynthetic enzyme / Rubisco is used and allows the Calvin cycle to continue;;

[Total: 10]

- 6 An inbred variety of maize, **A**, with finely striped leaves was found to have high resistance to the fungus that causes the disease, corn leaf blight.

Plants of variety **A** were crossed with another inbred variety of maize, **B**, which had entirely green leaves and low resistance to the fungus. All the F<sub>1</sub> generation had entirely green leaves and low resistance.

The above F<sub>1</sub> generation was test cross with variety **A** and yielded the following results:

finely striped leaves and high resistance	80
finely striped leaves and low resistance	20
entirely green leaves and high resistance	22
entirely green leaves and low resistance	78

- (a) A chi-squared test was performed on the results of the cross to determine if the results of the test cross depart significantly from the expected ratio. Calculate the  $\chi^2$  value using the formula provided below. [1]

Formula for  $\chi^2$  calculation

$$\chi^2 = \sum \frac{(O-E)^2}{E} \quad v = c - 1$$

where  $\Sigma$  = 'sum of...'

v = degrees of freedom

c = number of classes

O = observed 'value'

E = expected 'value'

Category	Observed number (O)	Expected ratio	Expected number (E)	(O - E) <sup>2</sup>	$\frac{(O - E)^2}{E}$
finely striped leaves and high resistance	80	1	50	900	18
finely striped leaves and low resistance	20	1	50	900	18
entirely green leaves and high resistance	22	1	50	784	15.68

entirely green leaves and low resistance	78	1	50	784	15.68;
<b>TOTAL</b>	<b>200</b>				<b>67.36 (2 d.p.);</b>

Table 6.1

degree of freedom	probability, p				
	0.10	0.05	0.02	0.01	0.001
1	2.31	3.84	5.41	6.64	10.83
2	4.61	5.99	7.82	9.21	13.82
3	6.25	7.82	9.84	11.35	16.27
4	7.78	9.49	11.67	13.28	18.47

- (b) Using Table 6.1, explain the conclusion drawn from the  $\chi^2$  test to determine if the observed numbers conformed to the expected. [3]
- Since the calculated  $\chi^2$  value 67.36 more than critical value 7.82 at  $p = 0.05$  at d.f.= 3, null hypothesis is rejected.
  - At 3 degree of freedom
  - Value of  $p$  is less than 0.001.;
  - The results of the  $\chi^2$  test suggest that there is a significant difference between the observed and the expected values(1:1:1:1).
  - Any difference is not due to chance alone but other factors e.g linked genes are at work.
  - Reject null hypothesis;
- (c) Using the following symbols:
- |          |                     |          |                     |
|----------|---------------------|----------|---------------------|
| <b>G</b> | entirely green leaf | <b>g</b> | finely striped leaf |
| <b>R</b> | low resistance      | <b>r</b> | high resistance;    |

Draw a genetic diagram to explain the difference between expected and actual results of the cross.

F<sub>1</sub> phenotype : entirely green leaves and low resistance x finely striped leaves and high resistance

F<sub>1</sub> genotype (test cross) :  $\frac{G R}{g r}$  x  $\frac{g r}{g r}$

Gametes formed :  $\frac{GR}{}$   $\frac{gr}{}$   $\frac{Gr}{}$   $\frac{gR}{}$  x  $\frac{gr}{}$   
 Parental type recombinant type

**Punnett square**

	$\frac{GR}{}$	$\frac{gR}{}$	$\frac{Gr}{}$	$\frac{gr}{}$
$\frac{gr}{}$	$\frac{G R}{g r}$ entirely green, low resistance (Parental typed offspring)	$\frac{g R}{g r}$ striped leaves, low resistance (recombinant typed offspring)	$\frac{G r}{g r}$ entirely green, high resistance (recombinant typed offspring)	$\frac{g r}{g r}$ striped leaves, high resistance (parental typed offspring)

offspring Genotype :  $\frac{G R}{g r}$   $\frac{g R}{g r}$   $\frac{G r}{g r}$   $\frac{g r}{g r}$

offspring Phenotype : entirely green, low resistance striped leaves, low resistance entirely green, high resistance striped leaves, high resistance

;

;

[4]  
[Total:8]



7(a) Fig. 7.1 is an electron micrograph of a mitochondrion in a neurone.

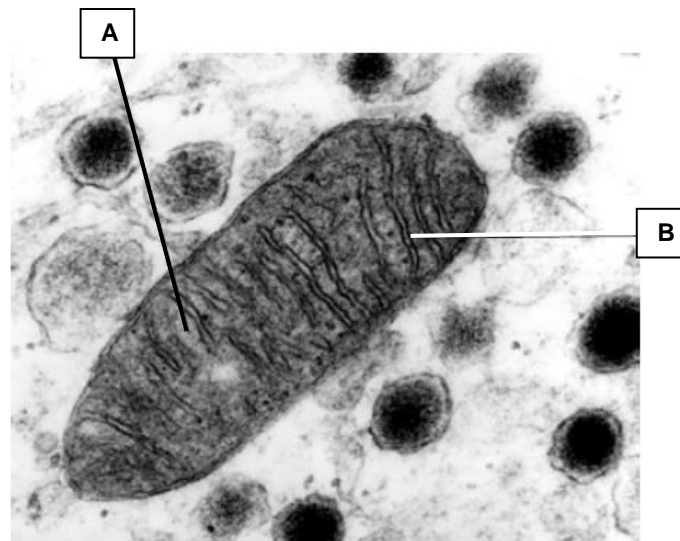

Fig. 7.1

Two stages of respiration occur in mitochondria. These are the Krebs cycle and oxidative phosphorylation.

- (i) Complete the table below by naming the structures labelled **A** and **B** and stating which of the stages of respiration occur in each.

	name of structure	stage of respiration
<b>A</b>	<b>matrix</b>	<b>Kreb cycle</b>
<b>B</b>	<b>cristae / inner membrane</b>	<b>oxidative phosphorylation</b>

- (ii) Explain the need for mitochondria along the axon in terms of nerve impulse conduction. [2]

**Along the neurone:**

- For production of ATP to release energy
- required to drive **sodium potassium pumps**
- Where 3 Na<sup>+</sup> are pumped out of cells and 2 K<sup>+</sup> are pumped into nerve cell; → **impt for RP**

**At end of axon where synapse is found:**

- For the **active pumping of Ca<sup>2+</sup> out** of the synapses after nerve impulses have been conducted across synapses.
- To release energy for the **transport of synaptic vesicles** which carry materials for the synthesis of membrane & **neurotransmitter** substances;
- For vesicles containing neurotransmitters to release their contents via **exocytosis** into the synaptic cleft when impulses arrive at the synapses;

- (b) Serotonin is a neurotransmitter which is produced by certain neurons in the brain. One of its effects is to increase the activity of sensory neurones in the brain. It also usually improves a person's mood and keeps the person awake. Fig. 7.2 shows a synapse at which serotonin is the neurotransmitter.

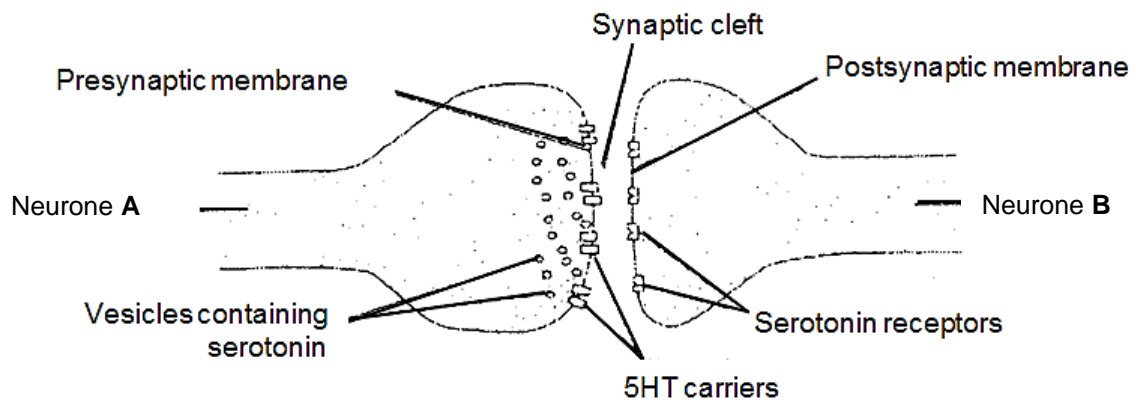

Fig. 7.2

- (i) Describe how the neurotransmitter is released into the synaptic cleft. [2]
- Arrival of nerve impulse/action potential
  - causes  $\text{Ca}^{2+}$  to enter/ influx of  $\text{Ca}^{2+}$  to cause
  - synaptic vesicles carrying the neurotransmitter, serotonin, move towards and fuse with the presynaptic membrane and
  - releases serotonin into synaptic cleft via exocytosis .
- (ii) Explain how the release of the neurotransmitter, serotonin, results in the transmission of an impulse from neuron A to neuron B. [2]
- Serotonin diffuses across the 20nm synaptic cleft post synaptic membrane
  - binding of serotonin to the receptors of ligand-gated  $\text{Na}^+$  channel on postsynaptic membrane;
  - As a result, ligand gated sodium ion gates on membrane open. Sodium ions rush/influx of sodium into membrane down its electrochemical gradient
  - to depolarize the post-synaptic membrane to generate an EPSP.
- (iii) Suggest why nerve impulse can only travel in one direction across a synapse. [1]
- Voltage-gated Ca channels are found only on the pre-synaptic membrane, allowing translocation of neurotransmitter vesicles;
  - Neurotransmitter vesicles are only found in the pre-synaptic neuron;
  - Receptors for neurotransmitter are only found on the post-synaptic membrane;

[Total: 10]

- 8 There are over 40 Galapagos Islands including the small and isolated island named Daphne Major.

Studies were made every year from 1970 to 1989 on the beak size of the island's population of ground finch, *Geospiza fortis*, by measuring the beak length of every bird (Fig. 8.1). Larger finches with larger beaks are better at opening large seeds.



**Fig. 8.1**

From 1976 to 1978 there was a drought and only 15% of the ground finches survived and these did not breed during drought years. The most conspicuous feature of the survivors of the drought years was their large beak size.

During normal years, many drought intolerant grasses and herbs produce an abundance of small seeds. A few other drought-tolerant plants produce a much smaller number of large seeds which are not normally eaten.

- (a)** Describe how environmental factors act as forces of natural selection, during drought years, on the beak size of finches. [4]

- Drought-tolerant plants which produced large seeds survived the drought better;;**
- The selection pressure being the type / availability of food source e.g. large seeds;;**
- Birds with larger beaks that can feed on large seeds are at selective advantage;;**
- can survive to maturity, mate, reproduce and pass on their favourable alleles (for larger beaks) to their offsprings;;**

- (b)** Suggest the role of the islands in the evolution of thirteen species of Darwin finches now found on the Galapagos Islands. [2]

- Geographical barrier / isolation between islands leads to reproductive isolation;;**
- Results in a lack of gene flow between population of finches;;**
- Different selection pressures on the different islands;;**

Molecular analysis was carried out on the mitochondrial DNA (mtDNA) sequences of the Galapagos Islands finches and the Cocos finch found on the island of Cocos, 830 km to north-east of the Galapagos islands. Using mtDNA analysis data, a map showing the phylogeny of these finches was constructed as shown below in Fig. 8.2

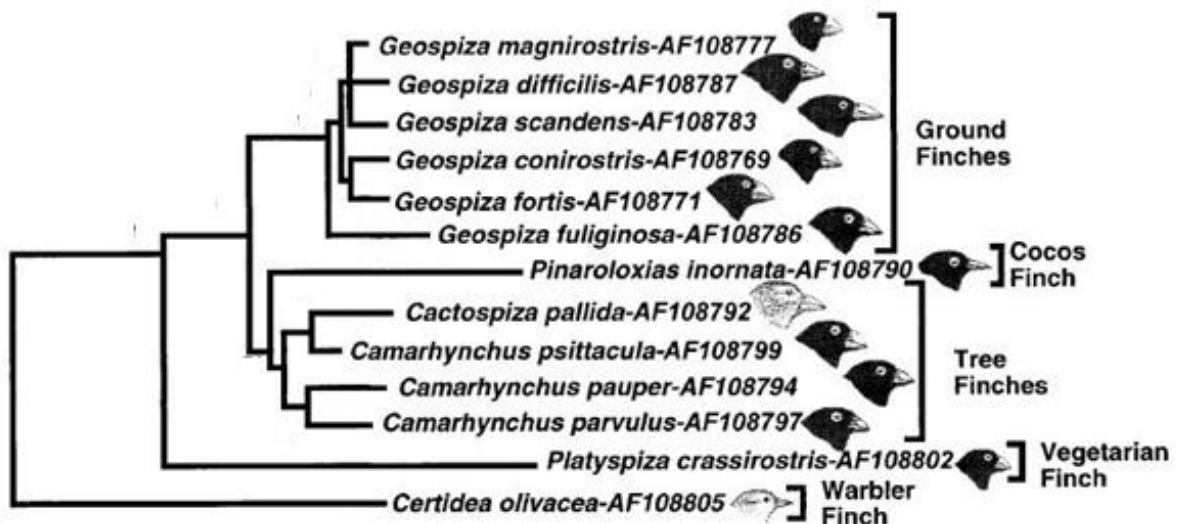

Fig. 8.2

(c) Explain how DNA sequences can be used to determine evolutionary relatedness between species. [2]

- a. Compare regions of homology in the same gene e.g. cytochrome c gene /  $\beta$ -chain haemoglobin gene found in different species / compare homologous genes between species;;
- b. The fewer the differences in DNA sequences of homologous genes between species, the more closely related the species are (vice-versa);;

(d) Describe the advantages of using nucleotide data such as mtDNA in classifying organisms.[2]

#### OWTTE

- a. Using nucleotide data is unambiguous and objective. A, T, G, C are easily recognized and not confused with one another. They are not dependent on subjective judgements or observations involving quantitative differences;;
- b. Nucleotide data are quantifiable and can be converted to numerical form and open to statistical and mathematical analysis. This provides a quantitative tool for constructing phylogenetic trees with branch points defined by mutations in DNA sequence;;

Differences in the *cytochrome b* DNA sequence of several finches' species from Galapagos Islands and Island of Cocos were measured and plotted against time since divergence from the primitive ancestor (MYA) as seen in Fig. 8.3.

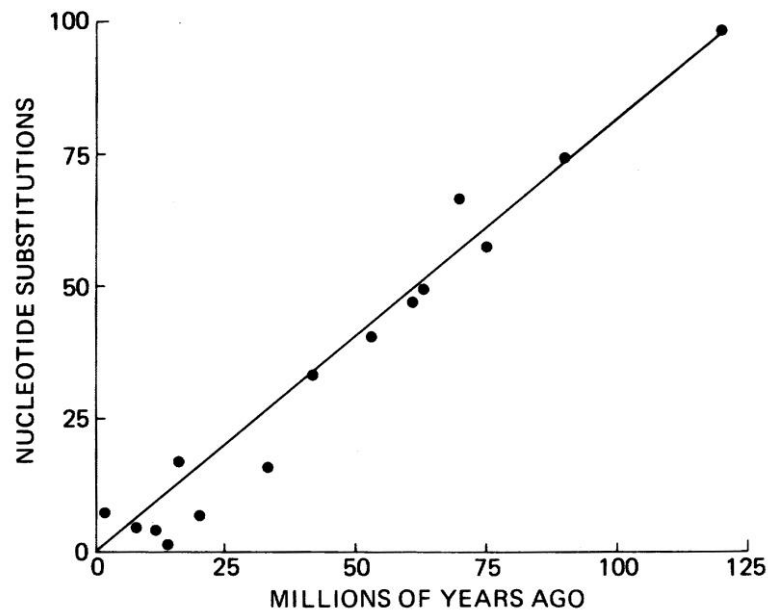

Fig 8.3

(e) Describe how these differences support the neutral theory of molecular evolution. [2]

- Changes in the nucleotide sequence arise through neutral mutation;
- for e.g. silent mutation or missense mutation where the change in amino acid does not occur in a critical region of the enzyme;
- There is no effect on the phenotype and fitness of organism/no selective advantage and thus allowed to accumulate;
- Small number of changes over millions of years indicating that rate of mutation is slow as cytochrome b gene is a crucial gene in living organisms;
- The plot of the line is straight, indicating that the rate of mutation is constant;

[Total: 12]

## Section B

Answer **one** question.

Write your answers to this question on the separate answer paper provided.

Your answers should be illustrated by large, clearly labelled diagrams, where appropriate.

Your answers must be in continuous prose, where appropriate.

Your answers must be set out in sections **(a)**, **(b)** etc., as indicated in the question.

9 (a) Compare and contrast between glucagon and glycogen.

[4]

Compare (At least 1m)

- a) Both are macromolecules.  
b) Both are involved in maintaining blood glucose concentration.

Contrast

Points of comparison	Glucagon	Glycogen
c) Type of biomolecule	Protein	Carbohydrate / Polysaccharide
d) Site of production	Alpha cells of islets of Langerhans in pancreas	Liver cells, Muscle cells
e) Monomer	Amino acids	Alpha glucose molecules
f) Bonds between monomers	Peptide bonds	Alpha 1,4 glycosidic bonds, alpha 1,6 glycosidic bonds for branching
g) Structure adopted by each biomolecule	Tertiary structure – precise globular conformation	Helical structures with regular branching
h) Bonds stabilizing structure	Ionic bonds between charged R-groups, hydrogen bonds between polar R groups, disulfide bridges, and hydrophobic interactions	Hydrogen bonds between – OH groups projecting into the helix
i) Solubility in water	Soluble	Insoluble
j) Function	A hormone that raises blood glucose level	Energy storage molecules in animals

(b) Explain what is meant by primary secondary, tertiary and quaternary structure of a named protein. [8]

**R: collagen**

- a) A protein with all 4 levels of structure is that of a globular protein, haemoglobin;
- b) Primary structure refers to the number, type and unique sequence of amino acids found;
- c) in each of the 4 polypeptide chains (2 alpha and 2 beta globin chains) linked by peptide bonds in a polypeptide chain;
- d) Secondary structure: segments of their polypeptide chain repeatedly coiled or folded;
- e) into some kind of geometrically regular secondary structure;
- f) The 2 main kinds are the  $\alpha$ -helix and the  $\beta$ -pleated sheet;
- g) Both structures are stabilized by intrachain hydrogen bonds between the amino and carboxyl groups of the polypeptide backbone;
- h) The secondary structures then fold back on themselves to form a precise globular structure;
- i) Tertiary structure refers to the overall compact, globular, 3-D structure of each haemoglobin polypeptide chain;
- j) conformation of a polypeptide resulting from interactions between side-chains of the various amino acids in a polypeptide chain;
- k) The compact structure is maintained by four types of bonds, namely hydrogen bonds, ionic bonds, hydrophobic interactions as well as the stronger disulfide bonds;
- l) As the polypeptide folds into its functional conformation, amino acids with hydrophobic (non-polar) side chains congregate in clusters via hydrophobic interactions at the core of the protein, out of contact with water;
- m) Meanwhile, hydrogen bonds between polar side-chains and ionic bonds between positively and negatively charged side-chains also help stabilize tertiary structure;
- n) These are all weak interactions but their cumulative effect help to stabilize and give the protein a unique shape;
- o) Quaternary structure refers to the specific orientation of 2 or more polypeptide chains with respect to one another and the nature of interactions that stabilize this orientation;
- p) Each polypeptide chain in such a protein is called a subunit;
- q) There are 4 subunits for haemoglobin, namely 2 alpha and 2 beta polypeptide chains;
- r) The subunits are held together by hydrogen bonds, ionic bonds and hydrophobic interactions to form a multimeric functional protein;

(c) Describe the main properties of an enzyme and discuss their mode of action.

[8]

- a) Enzyme acts as a biological catalyst which speeds up the rate of chemical reaction by lowering activation energy;
- b) It remains unchanged at the end of reaction and it can be reused;
- c) They are globular proteins with the specific 3D conformation;
- d) and specific distribution of electrical charges at its active site;
- e) They highly specific for the substrates they recognise and the reactions they catalyse;
- f) Some enzymes recognises also one type of substrate (eg: catalase) or a specific functional group (eg: phosphate group) or type of chemical bond (eg: peptide bonds).
- g) Enzyme activity is affected by changes in pH, temperature, substrate and enzyme concentration and in the presence of cofactors and inhibitors;
- h) Enzymes are extremely efficient. Catalysed reactions are  $10^3$  to  $10^8$  times faster than uncatalysed reactions;
- i) Enzymes have high turnover number. The turnover number refers to the number of substrate molecules converted into products by one molecule of enzyme in one second;
- j) They are required only in small amounts;

- k) Precise active site to which the substrate molecules with complementary conformation and compatible chemical groups become attached;
- l) Collision between substrate and enzyme at the correct orientation causes the substrate molecules to bind to the enzyme molecule at its active site to form an enzyme-substrate (E-S) complex;
- m) Enzyme and substrate are held together by weak bonds, such as ionic, hydrogen and hydrophobic bonds, which can be made and broken rapidly;

#### Lock and Key hypothesis

- n) The conformation and chemical groups of the substrate is exactly complementary to the enzyme active site;
- o) Substrate binds to the active site by weak bonds such as hydrogen and ionic bonds to form an enzyme-substrate complex;
- p) It is then activated to form the products of the reaction, which no longer fit into the active site of the enzyme;
- q) Products are released into the surrounding medium;
- r) leaving the active site unchanged and free to receive other substrate molecules;

#### Induced-fit hypothesis

- s) Initially, the active site does not exist in a conformation that is exactly complementary to the substrate;
- t) As the substrate enters the active site, the amino acids which make up the active site are moulded or 'induced' into a precise shape complementary to the substrate;
- u) This brings a greater interaction between the chemical groups of the substrate and active site. (greater chemical and spatial compatibility);
- v) Enables the enzyme to perform its catalytic function more efficiently;
- w) For example, in reactions involving 2 or more reactants, the active site brings the substrates together in the proper orientation for the reaction to occur;
- x) As the active site clutches the substrates, the enzyme may stress the substrate molecules, stretching and bending critical chemical bonds within the molecule that must be broken during the reaction;
- y) The active site may also provide a microenvironment that is conducive to a particular type of reaction;

[Total: 20]

10 (a) With reference to the islets of Langerhans, describe what is meant by an endocrine gland. [7]

- a) Islets of Langerhans are clusters of cells in pancreas;
- b) A gland is a structure which secretes specific chemical substances called hormones;
- c) Each islet has a population of alpha cells which secrete glucagon and;
- d) a population of beta cells which secrete insulin;
- e) Endocrine gland is ductless instead;
- f) hormones are secreted into blood to be distributed throughout the body;
- g) transported to target cells/tissue;
- h) Thus, islets of Langerhans have a rich supply of blood vessels;
- i) Endocrine glands secrete hormones in small quantities;
- j) Endocrine glands are involved in homeostatic control/homeostasis that operates by negative feedback;
- k) E.g. islets of Langerhans control the secretion of hormones/ adjust hormonal output by monitoring/detecting blood glucose concentration;

@ 1m each



**(b)** Explain how the blood glucose concentration is regulated by insulin and glucagon. [8]

**Regulation by insulin:**

- a) Blood glucose level is normally maintained at ~90 mg/100 ml blood;
- b) High blood glucose (>90 mg/100 ml blood) is detected by beta cells of islets of Langerhans;
- c) Beta cells are stimulated to secrete insulin directly into the bloodstream;
- d) Insulin binds to the (insulin) receptors on target cells e.g. liver and muscle cells;
- e) After insulin-binding process induces dimerisation & autophosphorylation of tyrosine amino acids on the RTK,
- f) the activated receptor tyrosine kinase then activates a number of bound intracellular relay proteins.
- g) As insulin level rises,
  - i. increases rate of glycogenesis (= conversion of glucose to glycogen) in liver and muscle cells;
  - ii. increases rate of glucose uptake/permeability esp. by muscle cells;
  - iii. increases conversion of glucose into fats in liver cells i.e. fat deposition;
  - iv. Increase in the rate of amino acid absorption and protein synthesis;
  - v. increases rate of respiration of glucose instead of other energy source (glycolysis);
  - vi. inhibits/decreases gluconeogenesis (= conversion of proteins and fats into glucose)
  - vii. Decrease in glycogenolysis, i.e. breakdown of glycogen to glucose in skeletal muscle and liver cells.  
(max 1m - any 2 pt)
- h) These mechanisms by insulin will lower blood glucose levels;
- i) When blood glucose level is restored to the normal set point/normal blood glucose concentration, beta cells detect and reduce insulin secretion.

**Regulation by glucagon:**

- j) Low blood glucose (< 90 mg/100 ml blood) is detected by alpha cells of islets of Langerhans;
- k) Alpha cells are stimulated to secrete glucagon directly into the bloodstream;
- l) Glucagon binds to the (glucagon) receptors on liver cells (only liver cells are glucagon's target i.e. only liver cells are sensitive to glucagon);
- m) to activate adenylyl cyclase (enzyme) to form cAMP i.e. increases cAMP level
- n) which activates phosphorylase enzymes that catalyse glycogenolysis (= conversion of glycogen to glucose);
- o) As glucagon level rises,
  - i. Increase in glycogenolysis = stimulate breakdown of glycogen to glucose;
  - ii. Stimulates triglyceride breakdown in adipocytes.
  - iii. Inhibits glycogenesis in liver and skeletal muscle cells
  - iv. Increase in gluconeogenesis  
(max 1m - any 2 pt)
- p) Newly synthesized glucose leaves target cells into the bloodstream;
- q) These mechanisms by glucagon will increase blood glucose levels;
- r) Secretions of insulin and glucagon are regulated by negative feedback mechanism.

**(c)** Describe how the endocrine system differs from the nervous system. [5]

	<b>Endocrine / hormonal system</b>	<b>Nervous system</b>
a) <b>Anatomical arrangement</b>	Endocrine glands widely dispersed in your body and not structurally related to one another or to their target cells.	Specific structural arrangement between neurons and their target cells; interlinked → structural continuity in the system.

<b>b) Type of information being transmitted and the messenger (s) involved</b>	<p>Relies on chemical transmission through the circulatory system; Information passes as a chemical messenger (hormone) thru blood stream.</p> <p>Hormones released into blood.</p>	<p>Involves both electrical &amp; chemical transmissions along nerve fibres and between nerve fibres; information passes as electrical impulses along axons of neurons and as chemical messenger (neurotransmitters) across synapses.</p> <p>Neurotransmitters released into synaptic cleft, never into blood. Electrical signal via nerve fibres.</p>
<b>c) Distance of action of chemical messenger</b>	<p>Long distance (carried by bloodstream – always exert its effect on target organs away from the site of synthesis)</p>	<p>Very short distance (diffuses across synaptic cleft) - neurotransmitter</p>
<b>d) Speed of transmission</b>	<p>Slow rate (relies on diffusion through the bloodstream)</p>	<p>Rapid rate (due to saltatory conduction of nerve impulses at the nodes of Ranvier)</p>
<b>e) Speed of response</b>	<p>Slow acting (from minutes to hours)</p>	<p>Rapid / immediate (in milliseconds)</p>
<b>f) Duration of action</b>	<p>Long lasting (from minutes to days or longer)</p>	<p>Brief / short-lived (in milliseconds)</p>
<b>g) Effects</b>	<p>Diffused; usu. Widespread</p>	<p>Localized; very precise &amp; exact</p>
<b>h) Major functions</b>	<p>Controls activities that require long duration rather than speed.</p>	<p>Coordinates rapid, precise responses; esp important in mediating interactions with the external environment.</p>

[Total: 20]

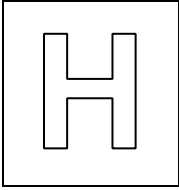

PIONEER JUNIOR COLLEGE  
 JC2 Preliminary Examinations  
 In preparation for General Certificate of Education Advanced Level  
 Higher 2

CANDIDATE  
 NAME

--

CT  
 GROUP

1	5	S		
---	---	---	--	--

INDEX  
 NUMBER

--	--	--	--

## BIOLOGY

**9648/03**

Application Paper and Planning Question

**19 September 2016**

Paper 3

**2 hours**

Additional Materials: Writing Paper

### READ THESE INSTRUCTIONS FIRST

Write your name, CT class and index number on all the work you hand in.  
 Write in dark blue or black pen.  
 You may use a soft pencil for any diagrams, graph or rough working.  
 Do not use paper clips, highlighters, glue or correction fluid.

Answer **all** questions.

The use of an approved scientific calculator is expected, where appropriate.  
 All working for numerical answers must be shown.

At the end of the examination, fasten all your work securely together.  
 The number of marks is given in brackets [ ] at the end of each question or part question

For Examiner's Use	
1	
2	
3	
4 Planning	
5	
<b>Total</b>	

This document consists of **17** printed pages including the cover page and **1** blank page.

**[Turn Over**

Answer **all** questions.

- 1 Bloom's syndrome is a rare autosomal recessive disorder. It is characterized by short stature, predisposition to the development of cancer and genomic instability. Bloom's syndrome is caused by mutations in the BLM gene leading to mutated DNA helicase protein formation.

In the early 1980s, attempts were made to map the BLM gene on chromosome 15 using DNA markers. The relationship between the BLM gene and two DNA markers DM1 and DM2 were studied in a family with many affected children. DNA were extracted from these individuals and cut with two different restriction enzymes separately. The products of digestion were separated using gel electrophoresis and the RFLP banding patterns is shown in Fig. 1.1 below.

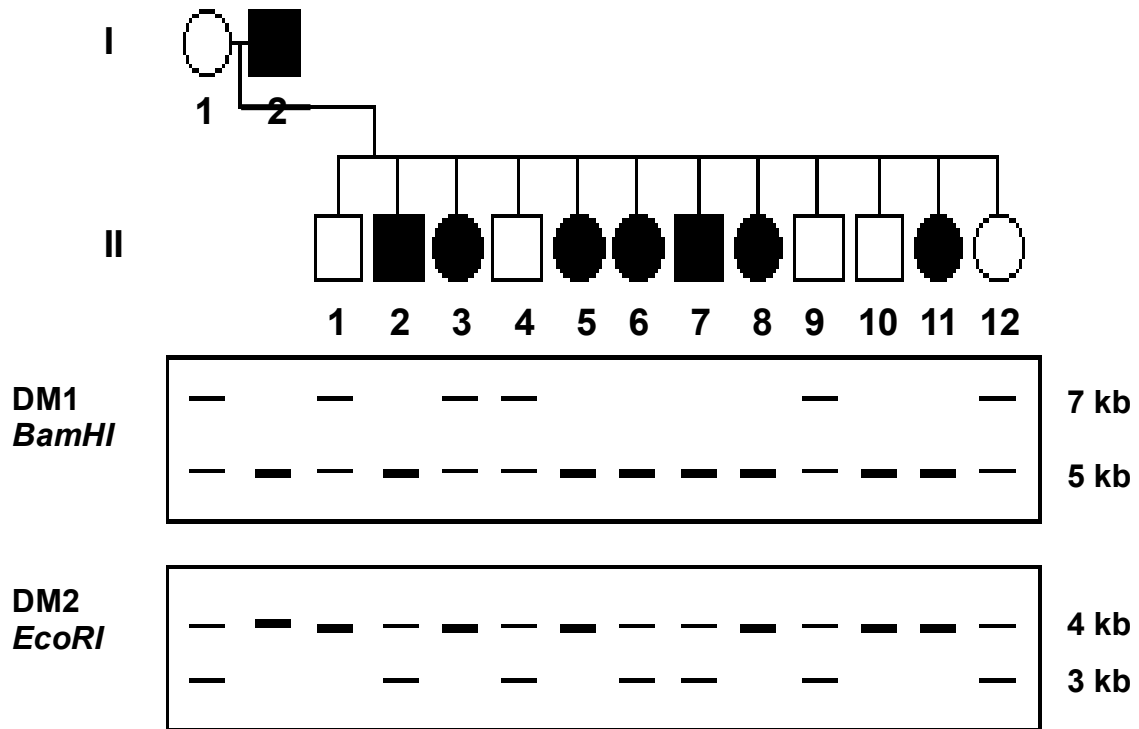

**Fig. 1.1**  
(Note: *BamHI* was used on DM1 and *EcoRI* on DM2)

**Key**

- |   |                            |   |                              |
|---|----------------------------|---|------------------------------|
|  | Male with Bloom's syndrome |  | Female with Bloom's syndrome |
|  | Normal male                |  | Normal Female                |

- (a) Explain why genes are seldom used as markers for genetic testing.

.....

.....

.....

.....

..... [2]

**(b)** What is meant by a restriction enzyme?

.....  
.....  
.....  
.....  
..... [2]

**(c)** Explain the principles behind Restriction Fragment Length Polymorphism (RFLP) analysis.

.....  
.....  
.....  
.....  
.....  
.....  
.....  
..... [3]

**(d)** Explain how gel electrophoresis can be used to distinguish between the different band patterns as observed in Fig. 1.1 using *Bam*HI.

.....  
.....  
.....  
.....  
.....  
.....  
.....  
..... [3]

**[Turn Over**

(e) Using the information provided in Fig. 1.1, deduce and explain which marker is more suitable in detecting the presence of Bloom's syndrome.

.....  
.....  
.....  
.....  
..... [2]

(f) Using your understanding of linked genes, provide a possible explanation for your answer in (e).

.....  
.....  
.....  
.....  
..... [2]

[Total: 14]

- 2 Severe Combined Immunodeficiency Disease (SCID) is the most severe of the immune deficiency diseases. SCID is a group of very rare, life-threatening diseases that are present at birth. Fig. 2.1 shows the pattern of inheritance of X-linked SCID in a family.

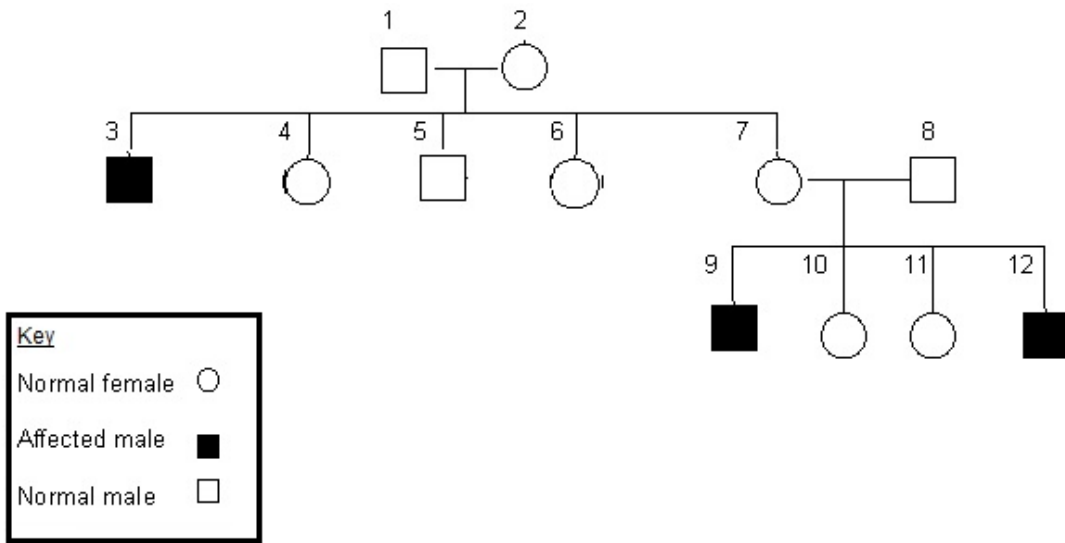

Fig. 2.1

- (a) State and explain the nature of alleles that gives rise to SCID illustrated in Fig. 2.1.

.....  
 .....  
 .....  
 .....  
 ..... [2]

- (b) Describe the genetic basis of X-linked SCID.

.....  
 .....  
 .....  
 .....  
 .....  
 .....  
 ..... [3]

[Turn Over

(c) Give one reason why SCID is a suitable choice for gene therapy.

.....  
.....  
..... [1]

Babies born with SCID have no defence against common infections and quickly become ill when the protection from maternal antibodies is lost. Gene therapy for SCID has been carried out using the general procedure shown in Fig. 2.2.

**Step 1:** Hematopoietic stem cells retrieved from baby's umbilical cord blood.



**Step 2:** Stem cells infected with harmless genetically engineered virus containing the normal, dominant allele.



**Step 3:** Stem cells take up normal allele.



**Step 4:** Stem cells transfused back into baby.



**Step 5:** Immune system develops T and B lymphocytes.

**Fig. 2.2**

(d) Using the information given, state **two** reasons why stem cells were used in this treatment.

.....  
.....  
.....  
.....  
.....  
..... [2]



In 2002, two young patients with X-linked SCID were treated with their own blood stem cells that had been subjected to the same treatment as the earlier attempts at gene therapy.

The two different forms of SCID require different cells to be targeted for gene therapy. For X-linked SCID, only stem cells can be used while in autosomal recessive form of SCID (ADA), both T cells and stem cells could be used. If T cells are used, they will be induced to proliferate *in vitro* by treatment with relevant signalling molecules before infection with viral vectors.

(e) From the information given and your knowledge of SCID, explain why different cells are used for different treatments.

.....

.....

.....

.....

.....

.....

..... [2]

Fig. 2.3 shows the lymphocyte counts (both T & B) of two infant patients that underwent two separate types of gene therapy treatments for SCID. Patient A was treated with a retrovirus while Patient B was treated with an adenovirus. The lymphocyte count of the patients was monitored by a doctor at the end of every month for a period of 12 months. (The acceptable range of lymphocyte count for non-SCID patients is  $5$  to  $10 \times 10^3/\text{mm}^3$ ).

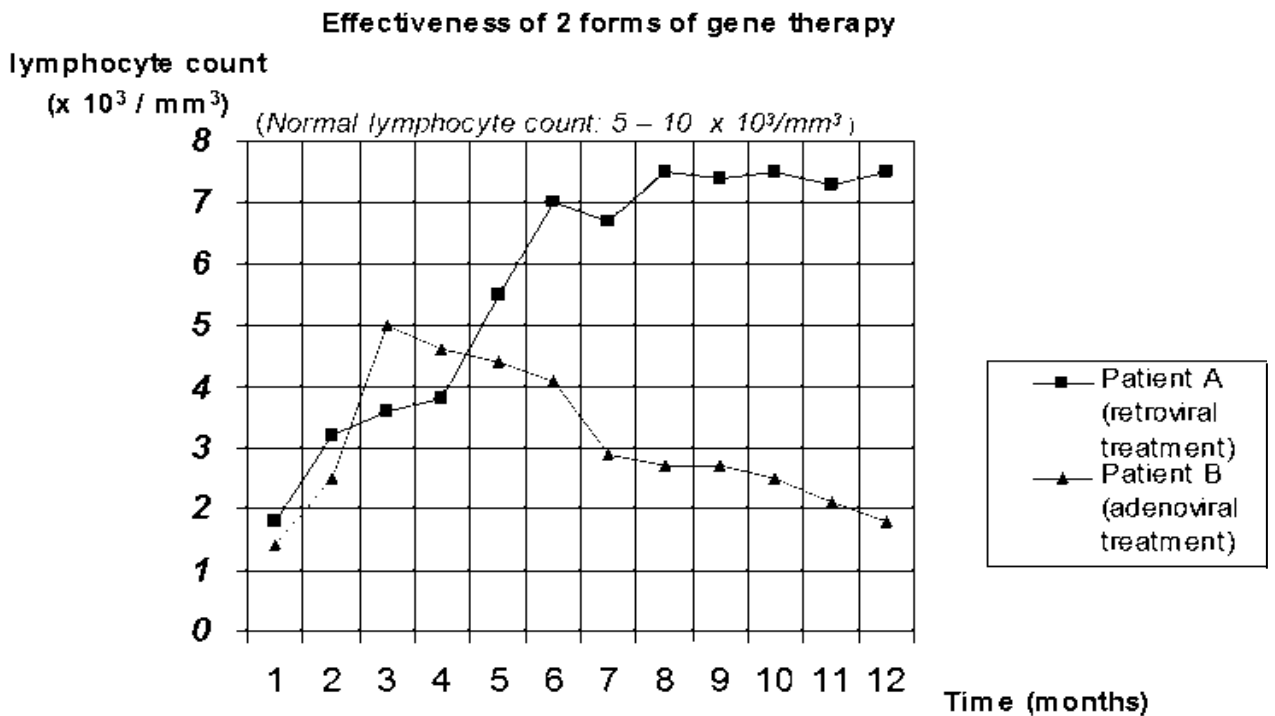

Fig. 2.3

[Turn Over

**(f)** With reference to Fig. 2.3,

**(i)** describe the trends observed in both patients' lymphocyte count.

.....  
.....  
.....  
.....  
..... [2]

**(ii)** account for the difference in lymphocyte count at the end of 12 months.

.....  
.....  
.....  
.....  
..... [2]

[Total: 14]



**(b)** Other experiments show that E $\beta$ f attracts predators of aphids, such as ladybirds. Suggest how growing genetically modified wheat secreting E $\beta$ f could increase the yield of wheat.

.....  
.....  
..... [1]

**(c)** Suggest why growing this genetically modified wheat might be acceptable to people who object to the growth of genetically modified insect-resistant maize or cotton.

.....  
.....  
.....  
.....  
..... [2]

In a separate experiment, Ti (Tumour-inducing) plasmid found in *Agrobacterium tumefaciens* was used to transfer DNA of interest into *T. triticum*. The transformed wheat protoplasts are stimulated to divide by mitosis to form calli and regenerated into whole plants by tissue culture techniques.

**(d)** With reference to tissue culture techniques, describe how plant growth regulators can result in plantlet formation from calli.

.....  
.....  
.....  
.....  
..... [2]

Plasmids are small circles of DNA that can be found in many bacteria which can be used for cloning foreign genes in suitable bacteria.

The plasmid, pUC19, shown in Fig. 3.2 has been developed for specific purposes by genetic engineers.

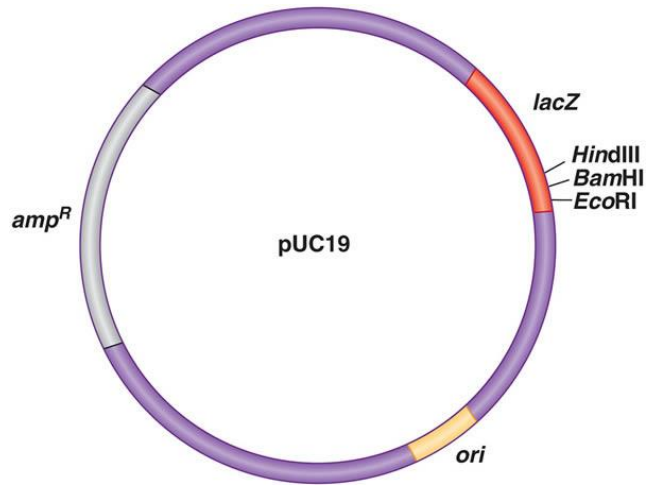

**Fig. 3.2**

pUC19 can be cleaved using restriction enzymes such as HindIII. HindIII can be found naturally in *Haemophilus influenzae*.

**(e)** What is the natural role of restriction enzymes in *H. influenzae*?

.....  
.....  
.....  
.....  
..... [2]

**(f)** With reference to Fig. 3.2, explain how the cells which contain the recombinant plasmids are identified.

.....  
.....  
.....  
.....  
.....  
.....  
.....  
..... [3]

[Total: 12]

**[Turn Over**

#### 4 Planning question

Dormant seeds have a very low rate of respiration. When water is absorbed by dormant seeds, growth hormones are activated. These hormones activate genes that code for enzymes that hydrolyse stored food reserves used in respiration allowing the seed to grow and germinate. The respiration rate can be measured by oxygen usage per unit mass using a respirometer.

You are required to investigate the respiration rate of germinating seeds of different mass.

You are provided with the following materials and apparatus which you must use:

- Mung bean seeds of different mass that have been soaked in water for 24 hours
- Blue dye
- Soda lime pellets 
- Glass beads
- Rubber tubing connected to capillary tube of 4mm diameter
- Syringes
- Electronic weighing balance
- Scale paper

You may select from the following apparatus and use appropriate additional apparatus:

- Normal laboratory glassware e.g. test-tubes, beakers, measuring cylinders, graduated pipettes, glass rods etc
- Forceps
- Ruler
- Stopwatch
- Thermometer

Your plan should:

- have a clear and helpful structure such that the method you use is able to be repeated by anyone reading it,
- be illustrated by relevant diagram(s), if necessary,
- identify the independent and dependent variables,
- describe the method with the scientific reasoning used to decide the method so that the results are as accurate and reliable as possible,
- show how you will record your results and the proposed layout of results tables and graphs,
- use the correct technical and scientific terms,
- include reference to safety measures to minimise any risks associated with the proposed experiment.

[Total: 12]











## 5 Free-response question

Write your answers to this question on the separate answer paper provided.

Your answers:

- should be illustrated by large, clearly labelled diagrams, where appropriate,
- must be in continuous prose, where appropriate,
- must be set out in sections **(a)**, **(b)** etc., as indicated in the question.

**(a)** Describe PCR and explain the advantages and limitations of this technique. [8]

**(b)** Describe how plant tissue culture is used to clone plant cells. Explain the scientific reasons for each step in the process. [8]

**(c)** Distinguish between a genomic DNA library and a cDNA library. [4]

[Total: 20]

[Turn Over

**BLANK PAGE**

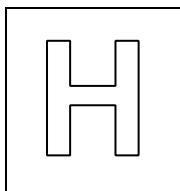

## JC2 Preliminary Examinations

In preparation for General Certificate of Education Advanced Level  
Higher 2

CANDIDATE  
NAME

--

CT  
GROUP

1	5	S	
---	---	---	--

INDEX  
NUMBER

--	--	--	--

### **BIOLOGY**

**9648/03**

Application Paper and Planning Question

**19 September 2016**

Paper 3

**2 hours**

Additional Materials: Writing Paper

### **READ THESE INSTRUCTIONS FIRST**

Write your name, CT class and index number on all the work you hand in.

Write in dark blue or black pen.

You may use a soft pencil for any diagrams, graph or rough working.

Do not use paper clips, highlighters, glue or correction fluid.

Answer **all** questions.

The use of an approved scientific calculator is expected, where appropriate.

All working for numerical answers must be shown.

At the end of the examination, fasten all your work securely together.

The number of marks is given in brackets [ ] at the end of each question or part question

<b>For Examiner's Use</b>	
<b>1</b>	
<b>2</b>	
<b>3</b>	
<b>4</b> Planning	
<b>5</b>	
<b>Total</b>	

This document consists of **17** printed pages including the cover page and **1** blank page.

**[Turn Over**

Answer **all** questions.

- 1 Bloom's syndrome is a rare autosomal recessive disorder. It is characterized by short stature, predisposition to the development of cancer and genomic instability. Bloom's syndrome is caused by mutations in the BLM gene leading to mutated DNA helicase protein formation.

In the early 1980s, attempts were made to map the BLM gene on chromosome 15 using DNA markers. The relationship between the BLM gene and two DNA markers DM1 and DM2 were studied in a family with many affected children. DNA were extracted from these individuals and cut with two different restriction enzymes separately. The products of digestion were separated using gel electrophoresis and the RFLP banding patterns is shown in Fig. 1.1 below.

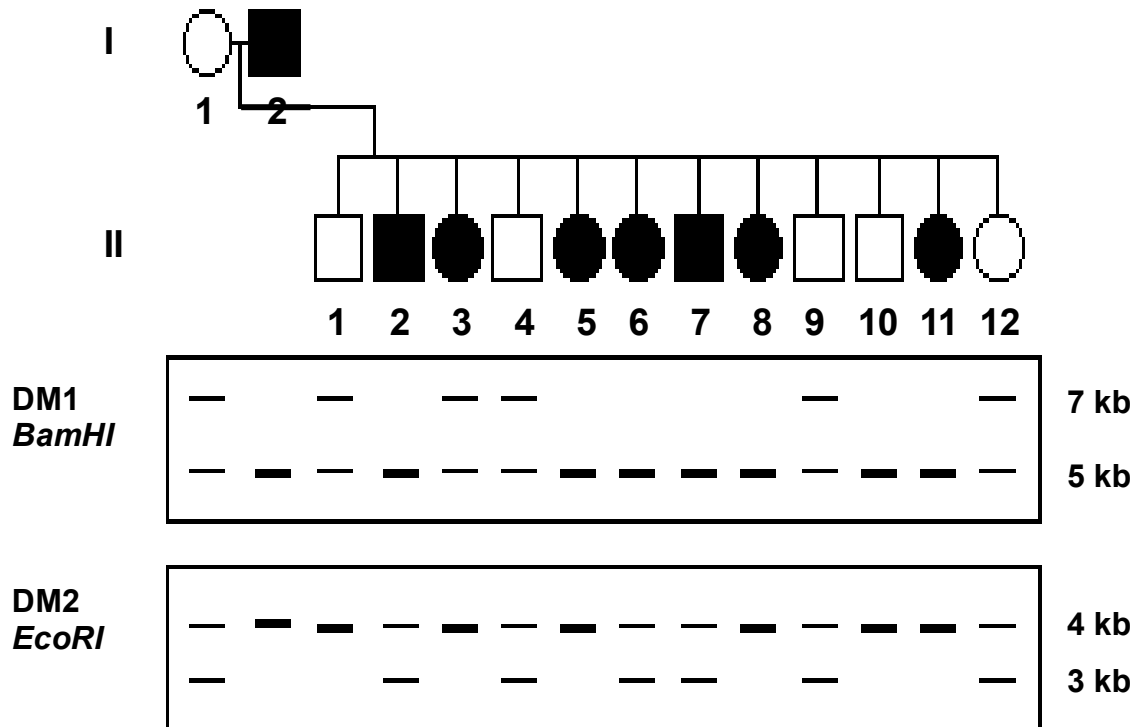

**Fig. 1.1**

(Note: *BamHI* was used on DM1 and *EcoRI* on DM2)

**Key**

	Male with Bloom's syndrome		Female with Bloom's syndrome
	Normal male		Normal Female

- (a) Explain why genes are seldom used as markers for genetic testing. [2]

- a) genes encodes a functional polypeptide;
- b) sequence of DNA is normally conserved due to its important biological function;
- c) mutation rate in genes is lower than in non-coding regions;
- d) not able to differentiate between individuals;

- (b) What is meant by a restriction enzyme? [2]

- a) recognise a specific sequence at the RE site;
- b) ref. RE site being 4-6 bases long;

- c) and binds to the specific sequence of bases;
  - d) cuts/cleaves DNA;
  - e) through hydrolysis of phosphodiester bonds between nucleotides;
- Max 2

(c) Explain the principles behind Restriction Fragment Length Polymorphism (RFLP) analysis. [3]

- a) different individuals have genetic variations / different nucleotide sequences at same locus;
  - b) among individuals of a species;
  - c) caused by mutations;
  - d) found within coding or non-coding region;
  - e) giving rise to Gain or loss restriction sites;
  - f) cut with same RE;
  - g) result in different length of DNA fragments;
- Max 3m

(d) Explain how gel electrophoresis can be used to distinguish between the different band patterns as observed in Fig. 1.1 using *BamHI*. [3]

- a) DNA fragments can be separated based on molecular size using gel electrophoresis;
  - b) The gel provides a matrix, in which the DNA fragments have to maneuver through the pores of the gel;
  - c) Thus, in a fixed amount of time;
  - d) the larger DNA (7kb) will move a shorter distance, compared to a small fragment(5kb), which will move a longer distance thus nearer to the well;
  - e) DNA is negatively charged at neutral pH due to the phosphate group;
  - f) The wells in the gel are located near the cathode;
  - g) therefore DNA sample will migrate from negative (cathode) to positive (anode) poles when subjected to an electric field;
- Max 3m

(e) Using the information provided in Fig. 1.1, deduce and explain which marker is more suitable in detecting the presence of Bloom's syndrome. [2]

- a) DM1 – more suitable OR DM2 – less suitable;;

*Either*

- b) For DM1, 7 out of 8 (88%) of the individuals with BS have the only one 5kb band/ homozygous for the 5 kb fragments;
- c) 5 out of 8 (62.5%) of the BS individuals have only one 4kb band/ homozygous for the 4 kb fragments for DM2;

*Or*

- d) For DM1 - All individuals with Bloom's syndrome have only one 5kb band/ homozygous for the 5 kb fragments except II-3 who has 2 bands 5kb and 7 kb;
- e) For DM2 - 5 BS individuals have only one 4kb band/ homozygous for the 4 kb fragments and 4 BS individuals have 2 bands 3kb and 4kb / about equal number of BS individuals and normal individuals have a single 4kb band as well as 2 bands 3kb and 4kb;
- f) (So the inheritance of the DM1/5kb fragment is more consistent compared to DM2)

- (f) Using your understanding of linked genes, provide a possible explanation for your answer in (e). [2]

- DM1 closer to BLM gene compared to DM2;;  
(note: some form of comparison required between DM1 and DM2 before a full mark is given)
- Higher tendency for the 5kb fragment to be inherited together with the BLM gene;
- Hence lower number of recombinants for DM1 (individuals II-3 and II-10) compared to DM2 (II-1,2,6,7 and 10);

[Total: 14]

- 2 Severe Combined Immunodeficiency Disease (SCID) is the most severe of the immune deficiency diseases. SCID is a group of very rare, life-threatening diseases that are present at birth. Fig. 2.1 shows the pattern of inheritance of X-linked SCID in a family.

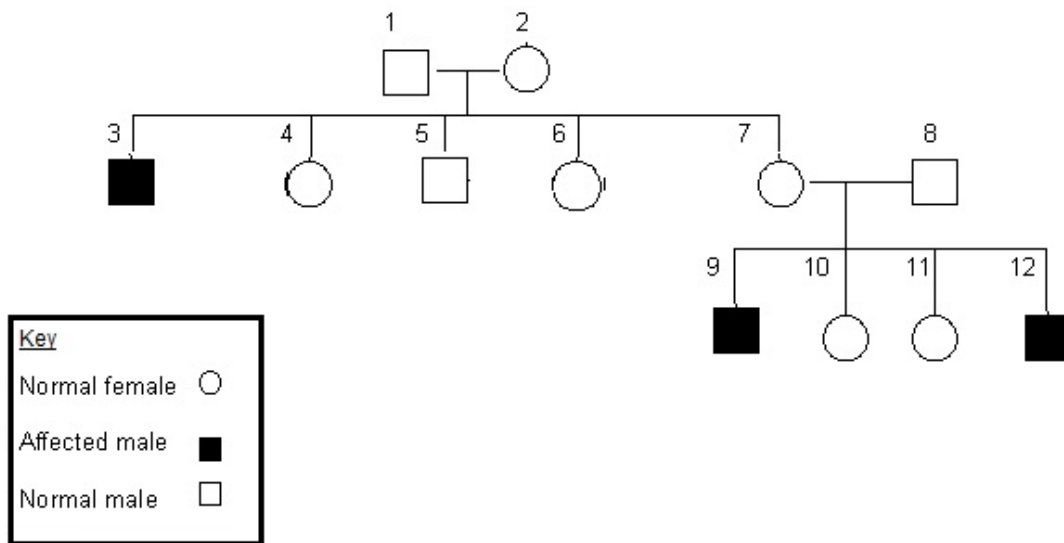

**Fig. 2.1**

- (a) State and explain the nature of alleles that gives rise to SCID illustrated in Fig. 2.1. [2]

- Recessive alleles;;
- Unaffected parents 1 & 2 have affected son 3/ Unaffected parents 7 & 8 with affected sons 9 & 12;;

- (b) Describe the genetic basis of X-linked SCID. [3]

- Interleukin-2-Receptor Gamma (IL2RG) gene found on the X chromosome;
- encodes common gamma chain subunit of the interleukin receptor;
- These receptors reside in the plasma membrane of immune cells;
- and allow communications between T and B cells/ immune cells;
- Mutations of IL2RG gene results in a non-functional version of the common gamma chain, or no protein formation;
- Without the common gamma chain, these interleukin-2-receptors cannot form /are absent from immune cells;
- hence preventing communication between T and B lymphocytes;
- These interleukins and their receptors are also involved in the development and differentiation of T and B cells;



- i) **The result is a near complete failure of the immune system to develop and function / low number or absence of T cells and non-functional B cells (B cells need T-helper cells to function);**

**Max 3m**

(c) Give one reason why SCID is a suitable choice for gene therapy. [1]

- a) **A mutation in 2 copies of IL2RG gene/ADA gene gives rise to SCID;**  
 b) **Only require one copy of normal/functional allele to be delivered to target cell for restoring the normal phenotype;**

Babies born with SCID have no defence against common infections and quickly become ill when the protection from maternal antibodies is lost. Gene therapy for SCID has been carried out using the general procedure shown in Fig. 2.2.

**Step 1:** Hematopoietic stem cells retrieved from baby's umbilical cord blood.



**Step 2:** Stem cells infected with harmless genetically engineered virus containing the normal, dominant allele.



**Step 3:** Stem cells take up normal allele.



**Step 4:** Stem cells transfused back into baby.



**Step 5:** Immune system develops T and B lymphocytes.

**Fig. 2.2**

(d) Using the information given, state **two** reasons why stem cells were used in this treatment. [2]

- a) **multipotent + differentiate into limited range of cell type;;**  
 b) **Unspecialised, no tissue-specific structures that allow specialized functions;;**  
**Reject: undifferentiated only**  
 c) **capable of dividing by mitosis and renew for long period of time/long term proliferation;;**  
 d) **stem cells used belong to the patient's hence there is low/no risk of immune rejection;;**

In 2002, two young patients with X-linked SCID were treated with their own blood stem cells that had been subjected to the same treatment as the earlier attempts at gene therapy.

The two different forms of SCID require different cells to be targeted for gene therapy. For X-linked SCID, only stem cells can be used while in autosomal recessive form of SCID (ADA), both T cells and stem cells could be used. If T cells are used, they will be induced to proliferate *in vitro* by treatment with relevant signalling molecules before infection with viral vectors.

(e) From the information given and your knowledge of SCID, explain why different cells are used for different treatments. [2]

- In X-linked SCID, IL2RG gene is mutated which results in the absence of functioning interleukin receptors;
- The patient's T cells cannot be stimulated to proliferate by treating them with Interleukin 2 (IL-2) before the infection with viral vector; therefore, T cells are not used for gene therapy for X-linked SCID and stem cells are used instead
- In autosomal recessive form of SCID, normal IL2RG gene is present;
- interleukin 2 receptors are functional in immune cells and can bind to IL2 therefore, both T cells and stem cells can be targeted;

Fig. 2.3 shows the lymphocyte counts (both T & B) of two infant patients that underwent two separate types of gene therapy treatments for SCID. Patient A was treated with a retrovirus while Patient B was treated with an adenovirus. The lymphocyte count of the patients was monitored by a doctor at the end of every month for a period of 12 months. (The acceptable range of lymphocyte count for non-SCID patients is  $5$  to  $10 \times 10^3/\text{mm}^3$ ).

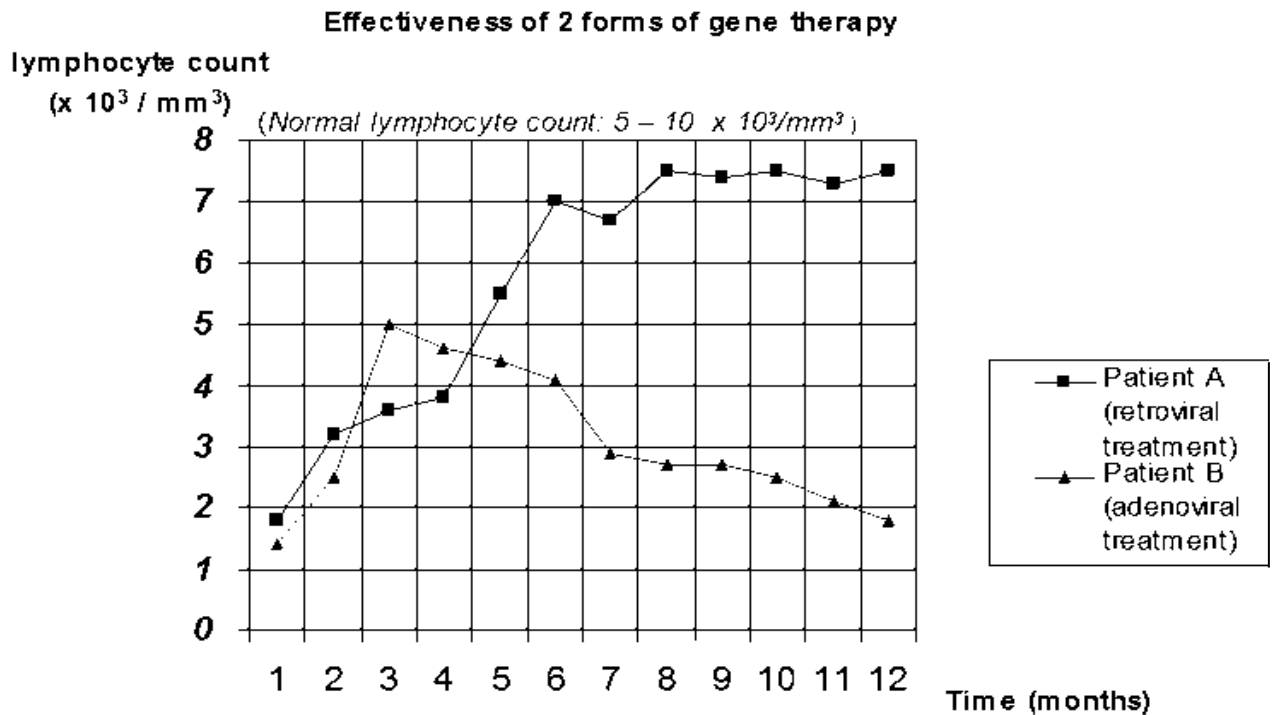

Fig. 2.3

(f) With reference to Fig. 2.3,

(i) describe the trends observed in both patients' lymphocyte count. [2]

- Patient A lymphocyte count increase from  $1.8$  to  $7.5 \times 10^3 / \text{mm}^3$  from 1 to 12 months / entered normal range by 5th month;;
- Patient B lymphocyte count increase to  $5 \times 10^3 / \text{mm}^3$ , from 1 to 3 months but decreased thereafter to  $1.8 \times 10^3 / \text{mm}^3$  from 3 to 12 months / entered into normal range by 3rd month;;

(ii) account for the difference in lymphocyte count at the end of 12 months. [2]

- a) retroviral vector allowed for integration of recombinant DNA that could be stably propagated hence resulting in long term stable expression / pass from parent to daughter cells;;
- b) adenovirus however could not integrate / exists extrachromosomally, into chromosomal DNA hence transferred gene does not segregate equally into daughter cells;;

**Reject: DNA gets degraded**

[Total: 14]

- 3 In 2012, permission was granted for a field trial in the UK of genetically modified wheat, *Triticum aestivum*. The wheat carries a gene, taken from peppermint plants, which results in the wheat leaves releasing a volatile, non-toxic chemical, (E)- $\beta$ -farnesene (E $\beta$ f), into the atmosphere.

E $\beta$ f is not only produced by various species of plants. It is also secreted by aphids when they are disturbed by a predator.

Two experiments have been performed into the effect of E $\beta$ f on the behaviour of aphids feeding on leaves in closed containers.

#### Experiment 1

Either 10 cm<sup>3</sup> of air from a syringe that contained plant leaves that secrete E $\beta$ f  
or 10 cm<sup>3</sup> of air from a syringe with normal leaves  
was added to the containers of feeding aphids.

#### Experiment 2

Either 10 cm<sup>3</sup> of air containing 50 ng of E $\beta$ f  
or 10 cm<sup>3</sup> of air containing no E $\beta$ f  
was added to the containers of feeding aphids.

In both experiments, the number of aphids that stopped feeding and moved away from the food leaves was counted. The results are shown in Table 3.1.

**Table 3.1**

Air added to containers of feeding aphids	Experiment 1		Experiment 2	
	10 cm <sup>3</sup> air that had been in contact with leaves secreting E $\beta$ f	10 cm <sup>3</sup> air that had not been in contact with leaves secreting E $\beta$ f	10 cm <sup>3</sup> air containing 50 ng E $\beta$ f	10 cm <sup>3</sup> air containing no E $\beta$ f
Number of aphids in container	99	113	132	106
Number of aphids that stopped feeding and moved away from the food leaves	54	1	111	0

- (a) With reference to Table 3.1, describe the evidences which support the idea that E $\beta$ f is an alarm signal for aphids. [2]

**Either**

- a) In the presence of E $\beta$ f, large number of aphids stopped feeding and moved away from food source (leaves), with 55% / 54 out of 99 aphids in experiment 1 compared to 84% / 111 out of 132 aphids in experiment 2 respectively;;  
 b) In the absence of E $\beta$ f, few / no aphids stopped feeding and moved away from food source with 1 aphid and none, in experiment 1 and 2 respectively;;

**Or**

- c) In experiment 1, 55% / 54 out of 99 aphids that were exposed to air that had been in contact with leaves secreting E $\beta$ f, stopped feeding and moved away from food source, compared to 0.9% / 1 out of 113 aphids that were exposed to air that had not been in contact with leaves secreting E $\beta$ f, stopped feeding and moved away from food source;;  
 d) In experiment 2, 84% / 111 out of 132 aphids that were exposed to air containing 50ng E $\beta$ f, stopped feeding and moved away from food source, compared to 0% / none of the 106 aphids that were exposed to 20 cm<sup>3</sup> air containing no E $\beta$ f, stopped feeding and moved away from food source;;
- (b) Other experiments show that E $\beta$ f attracts predators of aphids, such as ladybirds. Suggest how growing genetically modified wheat secreting E $\beta$ f could increase the yield of wheat. [1]

**Either**

- a) E $\beta$ f attracts predators of aphids / ladybirds which will prey on aphids;

**Or**

- b) attacked aphids / aphids disturbed by predators / ladybirds will secrete even more E $\beta$ f, which attracts more predators / ladybirds;  
 c) Aphids are not able to feed on wheat / obtain nutrients from GM wheat;
- (c) Suggest why growing this genetically modified wheat might be acceptable to people who object to the growth of genetically modified insect-resistant maize or cotton. [2]
- a) gene encoding for E $\beta$ f is already found in peppermint / various plant species' genomes;;  
 b) E $\beta$ f is not toxic / harmful to human health / no new chemical is added to human diet;;  
 c) Unlike Bt maize or Bt cotton, E $\beta$ f does not kill insects (since it is naturally secreted from aphids);;  
 d) Aphids are thus still available for their predators / minimal impact on the food chain;;

In a separate experiment, Ti (Tumour-inducing) plasmid found in *Agrobacterium tumefaciens* was used to transfer DNA of interest into *T. triticum*. The transformed wheat protoplasts are stimulated to divide by mitosis to form calli and regenerated into whole plants by tissue culture techniques.

- (d) With reference to tissue culture techniques, describe how plant growth regulators can result in plantlet formation from calli. [2]

**(Achieved by varying the ratio of plant growth regulators)**

- a) Higher proportion of auxin to cytokinin stimulates root growth and cell elongation;;  
 b) Higher proportion of cytokinin to auxin stimulates shoot growth and cell division;;

Plasmids are small circles of DNA that can be found in many bacteria which can be used for cloning foreign genes in suitable bacteria.

The plasmid, pUC19, shown in Fig. 3.2 has been developed for specific purposes by genetic engineers.

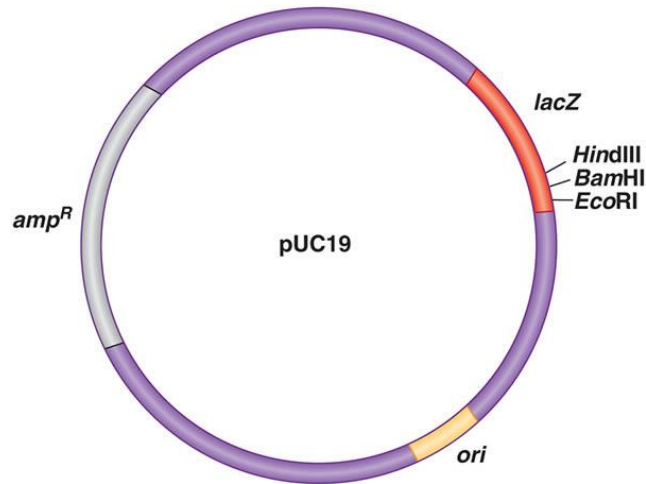

Fig. 3.2

pUC19 can be cleaved using restriction enzymes such as HindIII. HindIII can be found naturally in *Haemophilus influenzae*.

(e) What is the natural role of restriction enzymes in *H. influenzae*? [2]

- a) Protect bacterium against invading virus DNA/ foreign DNA;
- b) by cutting it up at specific sites (via breaking of phosphodiester bonds);
- c) Thus the enzyme helps to restrict foreign DNA from surviving/replicating in bacterium;
- d) Bacterium's own DNA is protected from digestion by methylation to the restriction sites;

**R: any usefulness to humans in genetic engineering**

(f) With reference to Fig. 3.2, explain how the cells which contain the recombinant plasmids are identified. [3]

- a) The bacteria are plated on an agar plate containing ampicillin to eliminate those with no uptake of the cloning vectors/untransformed cells (OWTTE);
- b) As those cells that are not transformed do not have the ampicillin resistant gene are not able to produce the enzyme that breaks down ampicillin;
- c) The same agar plate also contains X-Gal to select for cells with recombinant plasmids;
- d) Clones of bacteria that contain the gene of interest will appear white while those that do not contain the gene of interest will appear blue;
- e) As the gene of interest caused the insertional inactivation of the lac Z gene;
- f)  $\beta$ -galactosidase is not produced to break down X-gal, hence the colony remains white;
- g) Cells with normal plasmids will have an intact lac Z gene;
- h) which can be transcribed to produce  $\beta$ -galactosidase to break down X-gal to a blue product, causing the colony to appear blue;

Max 3m

[Total: 12]

#### 4 Planning question

Dormant seeds have a very low rate of respiration. When water is absorbed by dormant seeds, growth hormones are activated. These hormones activate genes that code for enzymes that hydrolyse stored food reserves used in respiration allowing the seed to grow and germinate. The respiration rate can be measured by oxygen usage per unit mass using a respirometer.

You are required to investigate the respiration rate of germinating seeds of different mass.

You are provided with the following materials and apparatus which you must use:

- Mung bean seeds of different mass that have been soaked in water for 24 hours
- Blue dye
- Soda lime pellets 
- Glass beads
- Rubber tubing connected to capillary tube of 4mm diameter
- Syringes
- Electronic weighing balance
- Scale paper

You may select from the following apparatus and use appropriate additional apparatus:

- Normal laboratory glassware e.g. test-tubes, beakers, measuring cylinders, graduated pipettes, glass rods etc
- Forceps
- Ruler
- Stopwatch
- Thermometer

Your plan should:

- have a clear and helpful structure such that the method you use is able to be repeated by anyone reading it,
- be illustrated by relevant diagram(s), if necessary,
- identify the independent and dependent variables,
- describe the method with the scientific reasoning used to decide the method so that the results are as accurate and reliable as possible,
- show how you will record your results and the proposed layout of results tables and graphs,
- use the correct technical and scientific terms,
- include reference to safety measures to minimise any risks associated with the proposed experiment.

[Total: 12]

## Suggested answer

### **Aim:**

To investigate the respiration rate of germinating seeds of different mass.

### **Background:**

- Ref to intake of  $H_2O$ , activation of growth hormone & enzyme that hydrolyse food reserves for respiration
- ref to aerobic respiration for production of ATP for cell division / growth
- need for  $O_2$  in respiration as final electron acceptor;;
- relate measurement of  $O_2$  uptake as indication of respiration rate

**Null Hypothesis:** Mung beans of different mass may have same / different respiration rate with logical suggestion e.g. same spp thus likely to be the same rate;;

### **Experimental Procedure:**

#### Labelled diagram

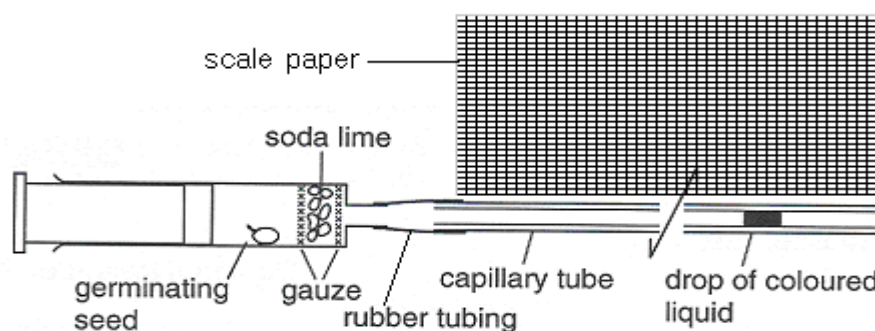

Fig. 1.0

- Set up the experiment in sets of 3.
- Remove the plunger from the syringe and place soda lime granules inside the syringe as shown in the set up above.
- Using a forceps, take 1 mung bean seedling and carefully remove and discard its testa (seed coat).
- Weigh it on the electronic weighing balance. Record your results.
- Place the mung bean in the syringe barrel and replace the plunger by pushing it in until it is about 0.5 cm from the seedling.
- Connect the glass capillary tube securely to the syringe using a rubber connecting tubing.
- Dip the end of the glass capillary tube into the blue dye so that a drop enters the capillary tube. (see the set up above)
- Remove any excess liquid with paper toweling.
- Place the respirometer horizontally on a piece of graph paper. Start the stopwatch and wait for 3 minutes to ensure that the manometer fluid is moving smoothly towards the syringe. Stop the stopwatch.
- Without handling the apparatus, measure the distance travelled by the manometer fluid in 3 consecutive time intervals of 1 min.

11. Do this by marking the position of the fluid on the graph paper and reading off the distances.  
(Alternatively, a piece of white paper can be used, and the markings measured using a ruler).
12. Record these results in the following table.

**Table of results recording the distance travelled by 5 different mung beans in each minute/mm**

Mung Bean	Weight of Mung Bean/g	Minute	Distance travelled in each minute/mm	Average distance travelled in each minute/mm	Rate of Respiration /min <sup>-1</sup> g <sup>-1</sup>
1		1			
		2			
		3			
2		1			
		2			
		3			
3		1			
		2			
		3			
4		1			
		2			
		3			
5		1			
		2			
		3			

13. Detach the syringe from the capillary tube by pulling it gently from the rubber connecting tube.
14. Fit another empty syringe to the capillary tube and flush out the manometer fluid onto a piece of filter paper so that the bore of the capillary tube is empty.
15. Carry out the same procedure for the rest of the 4 mung beans.
16. Repeat the entire experiment from step 1 to 15 twice more to ensure reproducibility of the experiment with fresh materials.
17. Calculate the rate of respiration in mm<sup>3</sup> of O<sub>2</sub> taken in min<sup>-1</sup> g<sup>-1</sup>

### **Variables**

**Independent variable:** 5 different masses of mung beans of reasonable range & regular intervals/g, weigh using electronic balance;;

**Dependent variable:** respiration rate measured by vol of O<sub>2</sub> uptake, inclusion of soda lime to absorb CO<sub>2</sub>, calculated from distance moved by dye droplet;;

**Control:** description of an appropriate setup using glass beads that occupies similar vol as mung beans to ensure that the mung beans are directly involved in the reaction.

### **Safety Precautions:**

- Soda lime is corrosive and a skin irritant. Be careful when handling this chemical and to be sure goggles and gloves are worn at all times.
- Handle glass wear with caution to prevent breaking of any fragile items.



## 5 Free-response question

Write your answers to this question on the separate answer paper provided.

Your answers:

- should be illustrated by large, clearly labelled diagrams, where appropriate,
- must be in continuous prose, where appropriate,
- must be set out in sections **(a)**, **(b)** etc., as indicated in the question.

**(a)** Describe PCR and explain the advantages and limitations of this technique. [8]

### Stage 1: Denaturation

- by heating to 90°C; [accept 90 – 100°C]
- DNA is separated into single strands by; **R: unwind**
- breaking of hydrogen bonds;

### Stage 2: Annealing of primers

- by cooling to 54°C; [accept 30 – 65°C]
- single-stranded;
- primers/ oligonucleotides bind to single (DNA) strands / 3' ends;
- by annealing/hybridise;
- to their complementary sequences on either side of the target sequence;

### Stage 3: Extension

- by heating to 72°C; [accept 60 – 75°C]
- optimum temperature (for Taq polymerase);
- new strands (of DNA) are synthesised by Taq/ DNA polymerase;
- starts at position of primers;
- addition of free deoxyribonucleotide to the free 3'OH end;
- through the formation of phosphodiester bond between the nucleotides;
- using the single strand DNA (target sequence) as a template;

**Points a) to o): ½ m each (max 5 m)**

### Advantages of PCR:

- Fast and efficient** way to amplify DNA with the exponential increase of the amount of DNA because the process of PCR can be **automated**;;
- PCR is **highly sensitive**. A target sequence can be amplified even when there is only a very **small amount** of the DNA available;;
- Give one useful example;;
  - Many copies of a gene of interest can be **amplified for cloning purposes**, as long as the primer sequences are known.
  - **Clinical diagnosis e.g. in prenatal diagnosis of human genetic disorders**. DNA from single embryonic cells is amplified using PCR. Screening for certain genetic diseases e.g. cystic fibrosis even before the phenotype is expressed provides assurance to the couple. If child is diagnosed with certain diseases, couple can then be prepared and make informed choices.
  - **Early detection of infection with HIV**: PCR can detect the presence of the HIV genome at very early stages of the diseases before symptoms appear.

- **Forensic science:** minute amount of DNA found e.g. at crime scene can be amplified to sufficiently large amounts to be analysed.
- **Study of fossil:** PCR is used to amplify fragments of ancient DNA from a 40,000 year old frozen woolly mammoth.

Limitations of PCR:

- s) Taq polymerase lacks the 3' to 5' proofreading mechanism. This makes it impossible for the enzyme to check the base it has just inserted and remove it if it is incorrect. Polymerase induced errors may accumulate during PCR;;
- t) PCR requires at least the knowledge of the sequences that flank the target DNA to synthesis the primers. Without proper primers, then PCR cannot take place;;
- u) DNA fragments are limited to 3 kb. Further increase in length will decrease the efficiency of amplification;;

**Points p) to u): 1 m each**

**Max 2m each for advantages/limitations**

- (b) Describe how plant tissue culture is used to clone plant cells. Explain the scientific reasons for each step in the process. [8]
- a) In micropropagation, plant tissues or explants e.g. meristematic cells are removed from plants or explants only;
- b) Reason: Meristematic regions are preferred as they are undifferentiated and virus-free;
- c) Surface of explants sterilised with dilute sodium hypochlorite (Clorox);
- d) Reason: To kill bacterial and fungal pathogens or organisms;
- e) And grown in a containing sterile media containing nutrients and plant growth regulators needed for plant growth;
- f) Containers holding the explants are then sealed and incubated for 1-9 weeks;
- g) Reason: All procedures must be sterile to ensure that microorganisms do not grow in the cultures as they would grow faster and out-compete the plants in these conditions;
- h) During this period, the cultured cells divide by mitosis;
- i) to form a mass of undifferentiated tissue called a callus;
- j) As callus increases in size, pieces of callus is sliced off and grown on new medium composition (subculturing);
- k) Reason: This creates many genetically identical clones of the original plant;
- l) By adjusting concentration of auxin to cytokinin ratio in growth medium;
- m) cells in callus can be induced to differentiate into roots and shoots;
- n) Reason: To enable plantlet formation;
- o) Further growth being encouraged by the use of plant growth substances until plantlets are large enough;
- p) Plantlets are taken out from culture vessels, washed to remove the agar, soaked in fungicide and antibiotics and then planted in sterile soil in green house for 4-8 weeks;
- q) Reason: This is to allow the plants to acclimatise from a heterotrophic to an autotrophic existence and the acclimatization of the plant to the outdoor environment;
- r) After acclimatization in green house, the plant are transferred to soil for field planting;

**Points a) to r): ½ m each (max 8 m)**

(c) Distinguish between a genomic DNA library and a cDNA library.

[4]

<b>Genomic DNA library</b>	<b>cDNA library</b>
<b>a) Contains all coding and non-coding sequences;</b>	<b>Expressed genes in the tissue – lack non-coding regions;</b>
<b>b) Cell's DNA cut using RE and inserted into vectors;</b>	<b>mRNA → cDNA using reverse transcriptase which is then inserted into vectors;</b>
<b>c) Need vectors ranging from plasmids to BAC to accommodate larger DNA sequences;</b>	<b>cDNA is relatively short, plasmids and <math>\lambda</math> phage often used as vectors;</b>
<b>d) A single gene can be spread out over different clones - A lot of DNA to isolate and analyse;</b>	<b>only contain coding sequences for that gene, which reduces the amount of DNA one has to isolate and analyse;</b>
<b>e) To study control of gene expression;</b>	<b>Isolate a particular gene that is active in a specialized cell and analyse its properties;</b>

**Any 4 differences, must be point to point comparisons (max 4 m)**

[Total: 20]