

**Tao Nan School  
Primary 3 Science  
End-of-Year Examination - 2005**

Name : \_\_\_\_\_ ( )

Date : 31 October 2005

Class : P3 \_\_\_\_\_

Time : 1 hr 15 min

Parent's Signature : \_\_\_\_\_

Marks : \_\_\_\_\_ / 100

**Section A ( 30 X 2 marks = 60 marks )**

For each question, choose the most suitable answer and shade its corresponding oval (1, 2, 3 or 4) in the optical response sheet.

1. Look at the diagram below.

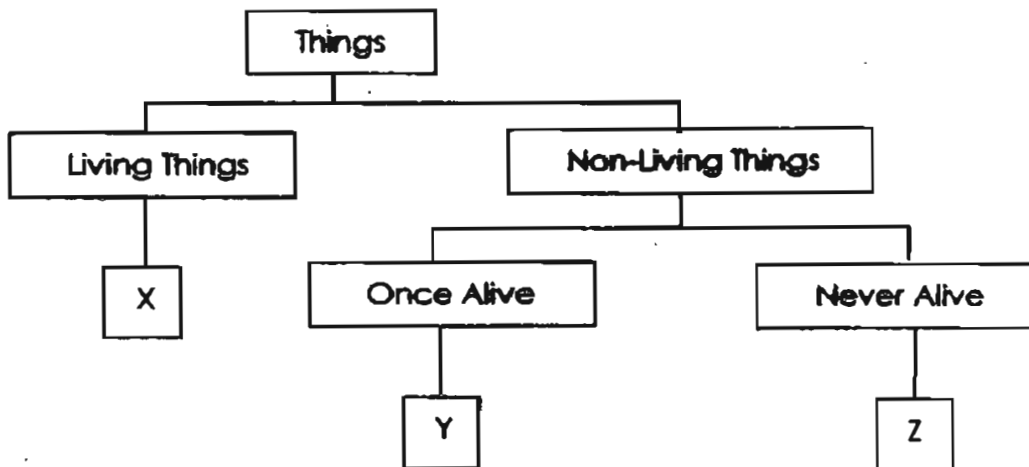

Which of the following things can 'X', 'Y' and 'Z' be ?

|     | X              | Y               | Z              |
|-----|----------------|-----------------|----------------|
| (1) | earthworm      | woollen sweater | leather wallet |
| (2) | mushroom       | magnet          | iron rod       |
| (3) | water hyacinth | wooden spoon    | raincoat       |
| (4) | feather        | elephant        | ballpoint pen  |

2. Ali left a pot of balsam plant in a totally dark room. After 5 days, he noticed that the plant had wilted. What should have been given to the balsam plant so that it would not wilt?

- A Air
- B Food
- C Water
- D Sunlight

- (1) A and B only
- (2) A and D only
- (3) B and C only
- (4) C and D only

3. Study the cactus and the bird's nest fern below carefully.



Cactus



Bird's Nest Fern

Which of the following statements about the two plants are true?

- |     |   |
|-----|---|
| A : | The cactus bears flowers but the Bird's Nest Fern does not. |
| B : | The cactus has a stem but the Bird's Nest Fern does not.    |
| C : | The cactus has leaves but the Bird's Nest Fern does not.    |

- (1) A only
- (2) A and B only
- (3) B and C only
- (4) A, B and C

4. Study the leaf below carefully. Where should this leaf be placed in the classification table below?

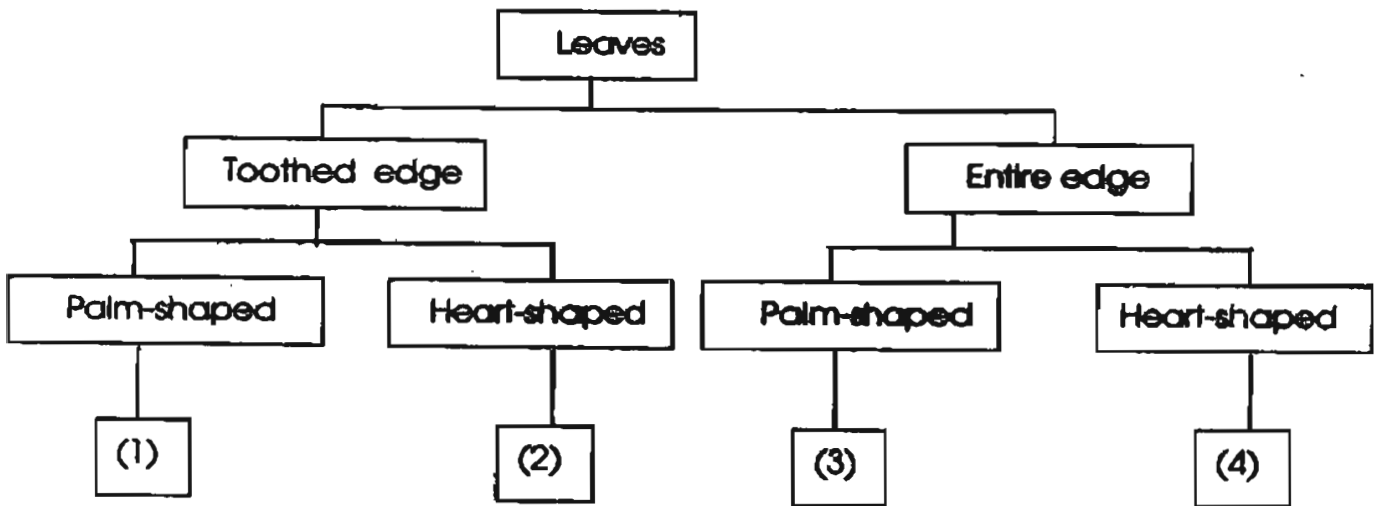
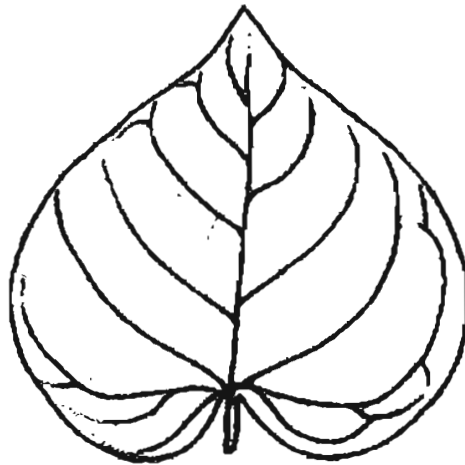

5. Study the plant below carefully. Which part of the plant develops into a fruit?

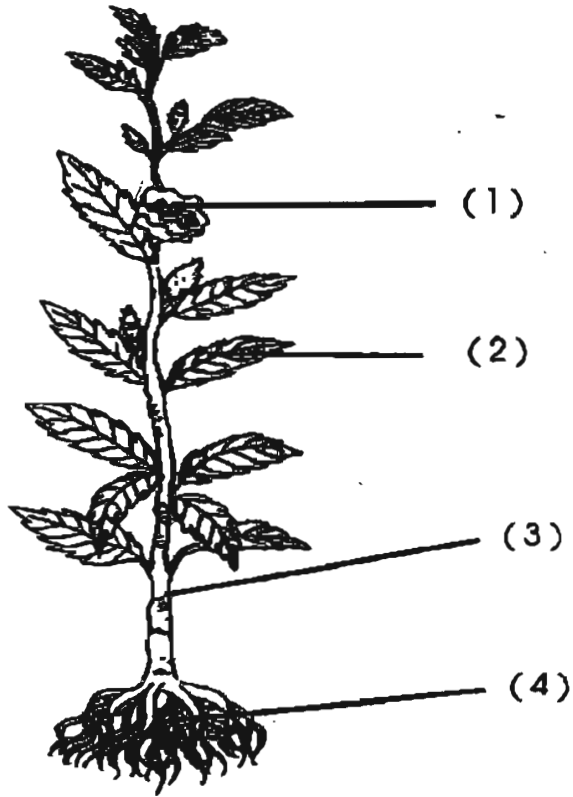

6. Which one of the following animals crawls to move around?



(1)



(2)



(3)



(4)

7. Which of the following animals does not belong to the same group as the other animals?

- (1) Seal
- (2) Shark
- (3) Whale
- (4) Dolphin

8. Study the three animals below carefully.



frog



penguin



dragonfly

How are they similar to one another?

- (1) They have three main body parts.
- (2) They live in water all the time.
- (3) They have young that looks like them.
- (4) They go through three stages in their life cycles.

9. The diagram below shows the life cycle of a beetle.

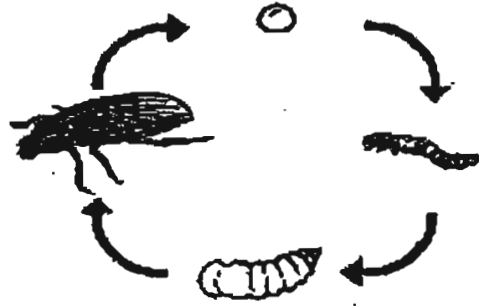

Which of the following animals has a life cycle most similar to the beetle?

- (1) Duck
- (2) Butterfly
- (3) Monkey
- (4) Cockroach

10. The pictures below show two rabbits and their young.

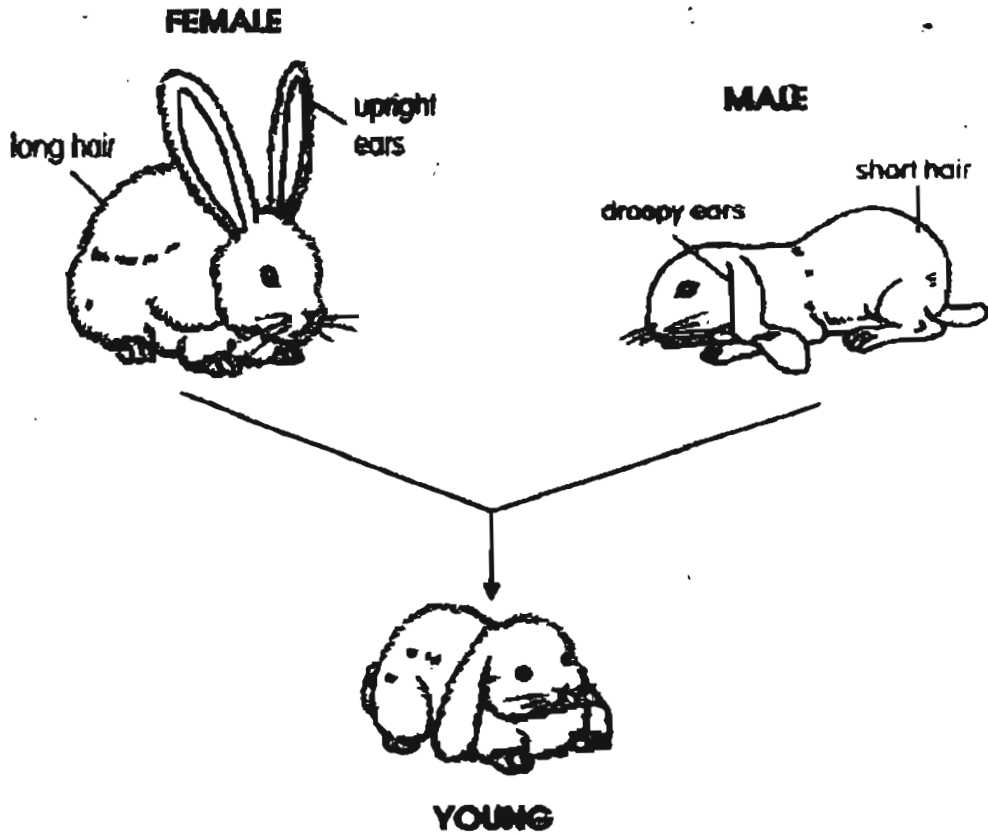

Which of the following statements below is true?

- (1) The young rabbit inherited her father's short hair.
- (2) The young rabbit inherited her mother's long hair.
- (3) The young rabbit inherited her father's upright ears.
- (4) The young rabbit inherited her mother's droopy ears.



11. Which of the following things is/are a system(s)?

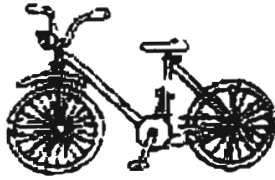

Bicycle

A



Cat

B



Plant

C



Thumbtack

D

- (1) A and D only
- (2) B and C only
- (3) A, B and C only
- (4) A, B, C and D

12. Which senses are being used when you cross a road?

- (1) Sight and taste.
- (2) Sight and touch.
- (3) Hearing and sight.
- (4) Smell and hearing.

13. Which of the following shows the correct order of the journey of food through our digestive system?

- (1) gullet → stomach → small intestine → large intestine
- (2) gullet → stomach → large intestine → small intestine
- (3) stomach → gullet → small intestine → large intestine
- (4) stomach → gullet → large intestine → small intestine

14. Which statement(s) about the heart and stomach is/are true?

- A Both can contract and relax.
- B Both are protected by the ribcage.
- C Both are part of the digestive system.

- (1) A only
- (2) B only
- (3) A and B only
- (4) B and C only

15. Which of the following is a function of our skeletal system?

- (1) It supports our body.
- (2) It removes waste from our body.
- (3) It carries food to all parts of our body.
- (4) It removes carbon dioxide from our body.

16. The statements below describe a fruit.

It is oval.  
It is sour.  
It is yellow.

What can the fruit be?

- (1) Lime
- (2) Lemon
- (3) Papaya
- (4) Banana

17. Study the concept map below carefully.

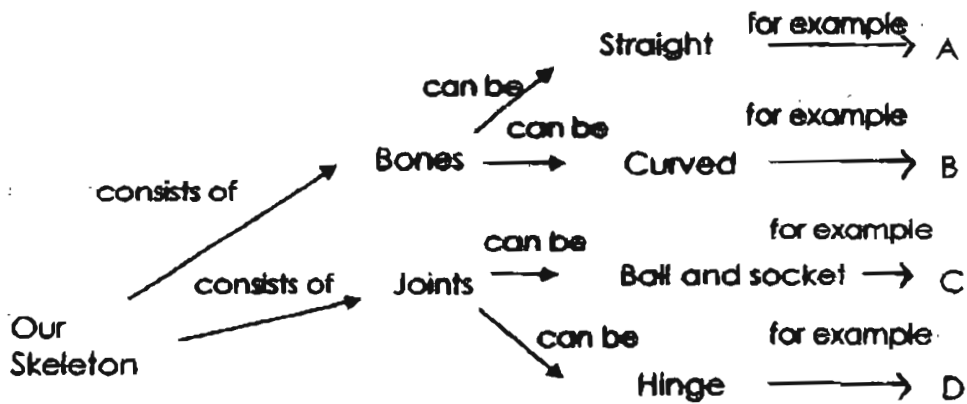

What can A, B, C and D be ?

|     | A         | B           | C               | D          |
|-----|-----------|-------------|-----------------|------------|
| (1) | ribcage   | shoulder    | knee            | thigh bone |
| (2) | shin bone | skull       | <u>hip bone</u> | knee       |
| (3) | skull     | finger bone | shoulder        | knee       |
| (4) | ribcage   | knee        | skull           | ribcage    |

18. Which of the following pictures shows the young of a mosquito?



(1)



(2)



(3)



(4)

19. Mr Tan left an orange on a table. After a few weeks, he saw green patches on the orange. What are these green patches?

- (1) Algae
- (2) Ferns
- (3) Moss
- (4) Mould

20. Which of the following describes a butterfly and a platypus?

|   | Lay eggs | Body is covered with hair | -Has a backbone |
|---|----------|---------------------------|-----------------|
| A | No       | No                        | No              |
| B | No       | Yes                       | No              |
| C | Yes      | No                        | No              |
| D | Yes      | Yes                       | Yes             |

|     | Platypus | Butterfly |
|-----|----------|-----------|
| (1) | A        | B         |
| (2) | D        | C         |
| (3) | B        | D         |
| (4) | C        | A         |

21. Study the picture of a grasshopper below carefully. Where are its wings found?

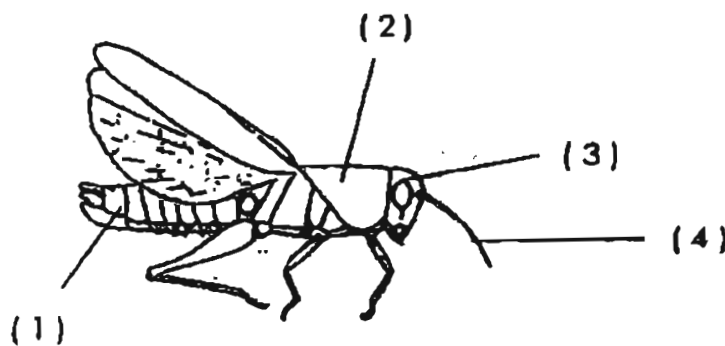

22. Which of the following statements is false?
- (1) Digestive juice is found in the stomach.
  - (2) The gullet is part of the digestive system.
  - (3) Digestion is completed in the large intestine.
  - (4) Blood transports digested food to other parts of the body.

23. Our body movements are caused by the interaction of our

---

- (1) digestive and skeletal system
- (2) skeletal and muscular system
- (3) skeletal and respiratory system
- (4) muscular and respiratory system

24. Lina grouped the following objects together.



basketball

tyre



rubber glove

What properties of the objects did she use to group them together?

- A All are round.
  - B All are man-made.
  - C All are made from plant materials.
- 
- (1) A only
  - (2) B only
  - (3) A and B only
  - (4) B and C only

25. David sees a brown cat. It purrs and runs towards him. It brushes its body against his leg. He feels its soft and warm fur. How many senses has David used?

- (1) Two
- (2) Three
- (3) Four
- (4) Five

26. The diagrams below show what happened when a wooden block was hung on strips A and B.

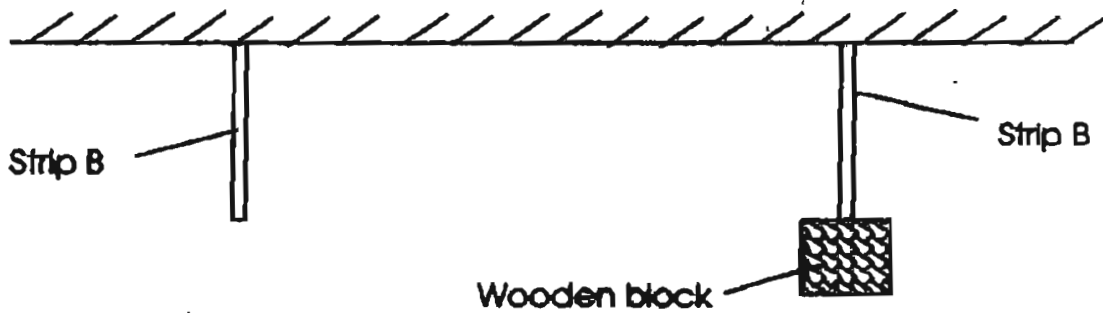
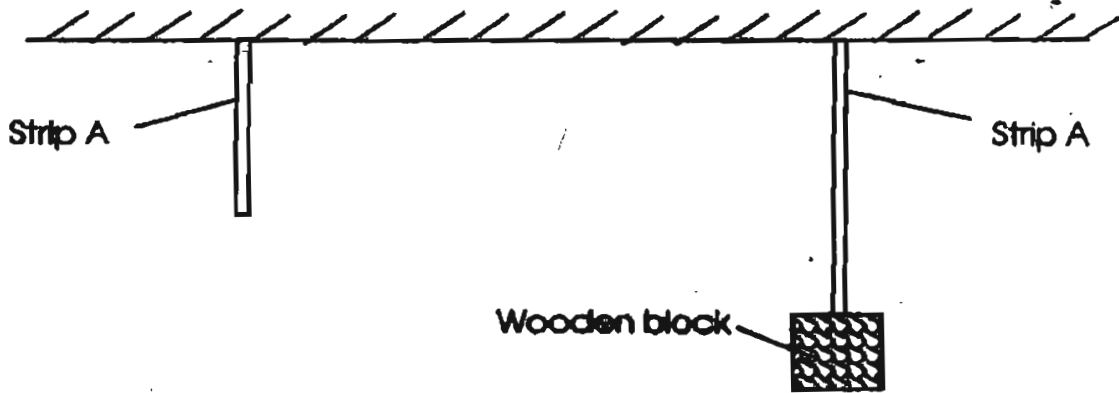

Which of the following correctly describes the property of the materials used to make strips A and B?

|     | Material used to make strip A | Material used to make strip B |
|-----|-------------------------------|-------------------------------|
| (1) | Elastic                       | Non-elastic                   |
| (2) | Soft                          | Hard                          |
| (3) | Opaque                        | Transparent                   |
| (4) | Cannot be compressed          | Can be compressed             |



27. Study the following set-up carefully.

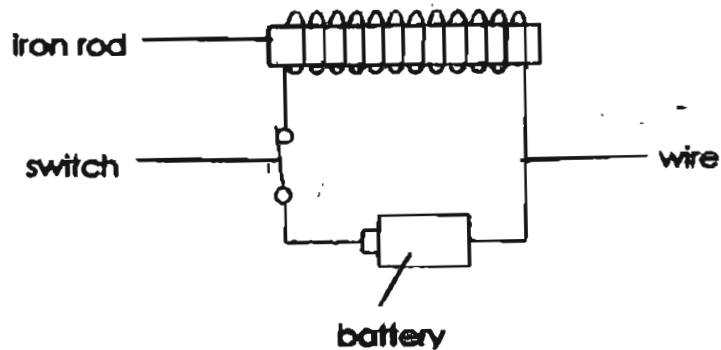

Which of the following affect the strength of the electromagnet?

|   |  |
|---|--|
| A | The position of the switch.                      |
| B | The colour of the wire used.                     |
| C | The number of batteries used.                    |
| D | The number of turns of wire around the iron rod. |

- (1) A and B only
- (2) A and D only
- (3) B and C only
- (4) C and D only

28. Which materials can be attracted by magnet?

- (1) Iron, steel and glass
- (2) Nickel, cobalt and iron
- (3) Steel, nickel and copper
- (4) Nickel, iron and aluminium

29. ~~When~~ happens to a magnet after it has been hit by a hammer continuously for five minutes?

- (1) The magnet increases in mass.
- (2) The magnet becomes weaker.
- (3) The magnet becomes stronger.
- (4) The magnet decreases in temperature.

30. Which of the following arrangements of 3 bar magnets is possible?

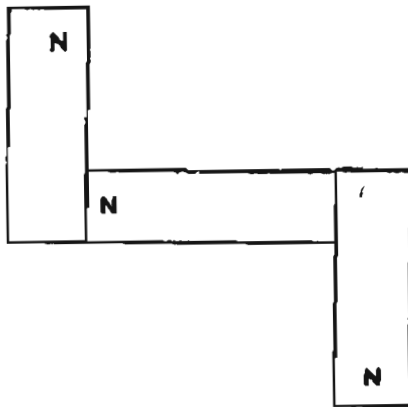

(1)

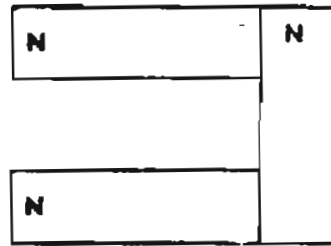

(2)

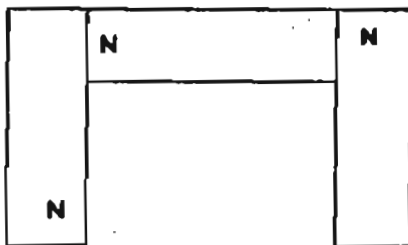

(3)

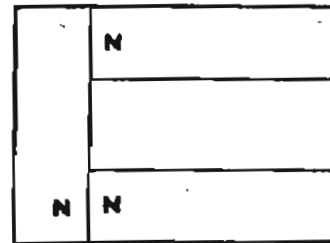

(4)

45

Name : \_\_\_\_\_ ( )

Class : P3 \_\_\_\_\_

**Section B ( 40 marks )**

**For questions 31 to 46, write your answers in the blanks provided.**

31. Study the classification table below. Place all the objects correctly into the classification table. (2 marks)

|               |             |           |           |
|---------------|-------------|-----------|-----------|
| plastic ruler | steel spoon | gold ring | iron nail |
|---------------|-------------|-----------|-----------|

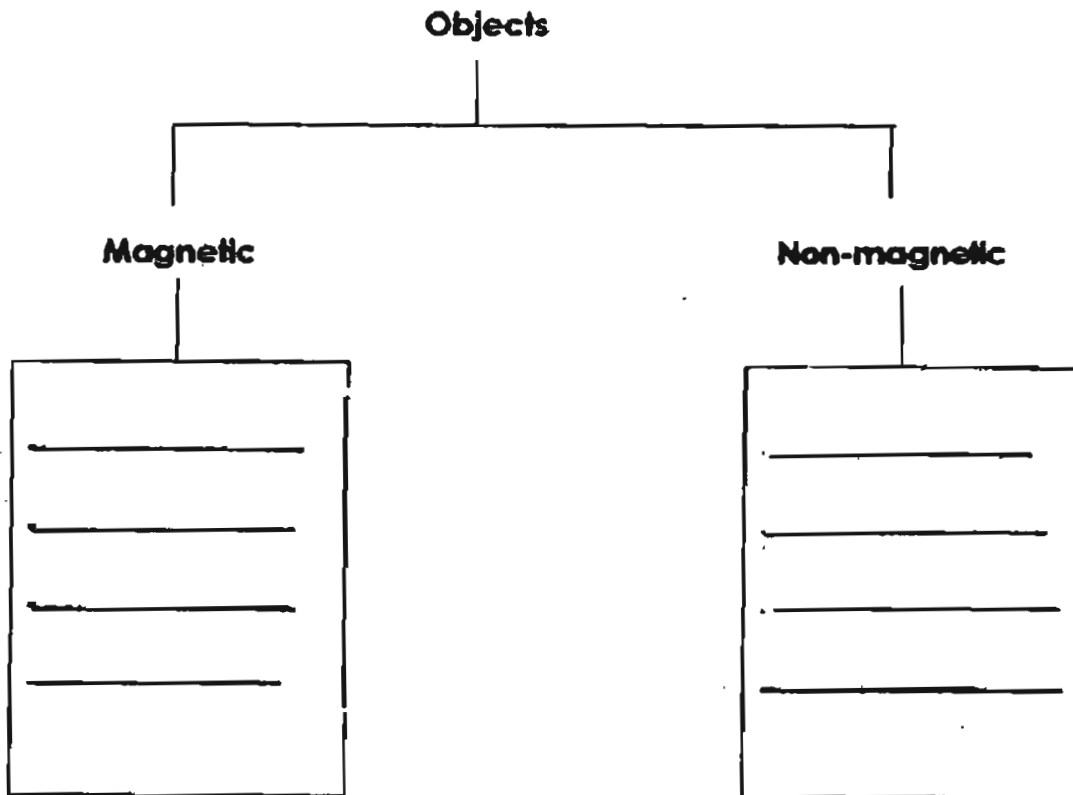

32. In the diagram below, the letters A, B, C, D, E and F represent 6 different plants. Classify the plants by writing the letters representing them in the correct boxes below. (3 marks)

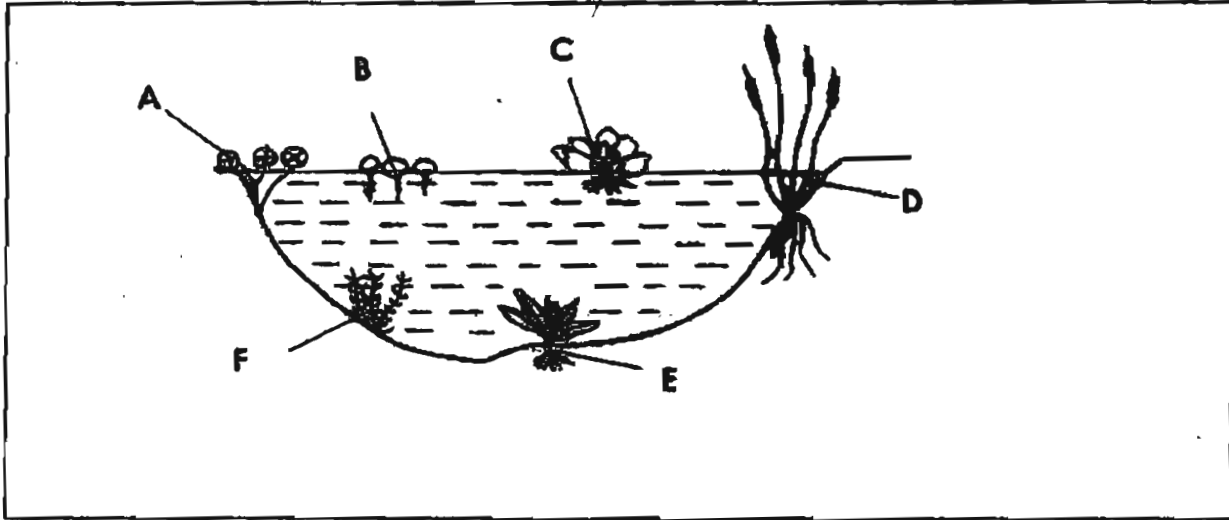

| AQUATIC PLANTS  |                     |          |
|-----------------|---------------------|----------|
| FULLY SUBMERGED | PARTIALLY SUBMERGED | FLOATING |
|                 |                     |          |
|                 |                     |          |
|                 |                     |          |
|                 |                     |          |
|                 |                     |          |
|                 |                     |          |

33. The diagram below shows a cut celery stalk put into a beaker of red-coloured water.

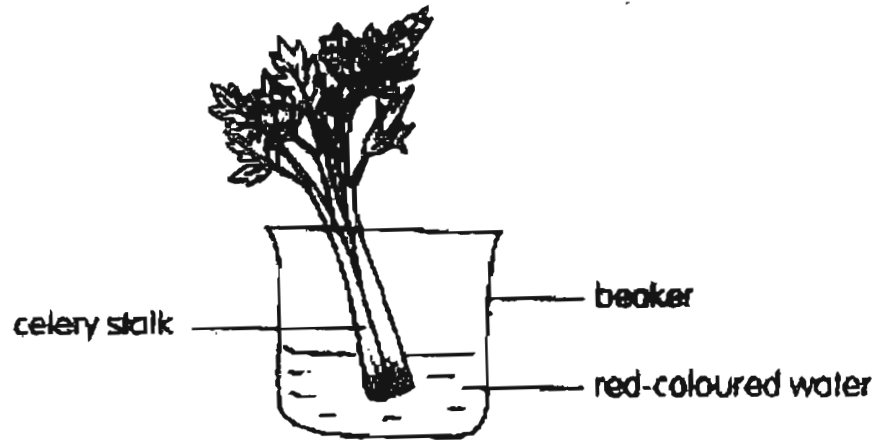

- (a) What will happen to the celery stalk after 2 days? (1 mark)

---

---

- (b) Explain your answer in part (a). (1 mark)

---

---

34. (a) Study the diagram of a leaf below carefully and fill in the blanks with the helping words given. (2 marks)

leaf blade      leaf stalk      leaf edge      branch vein

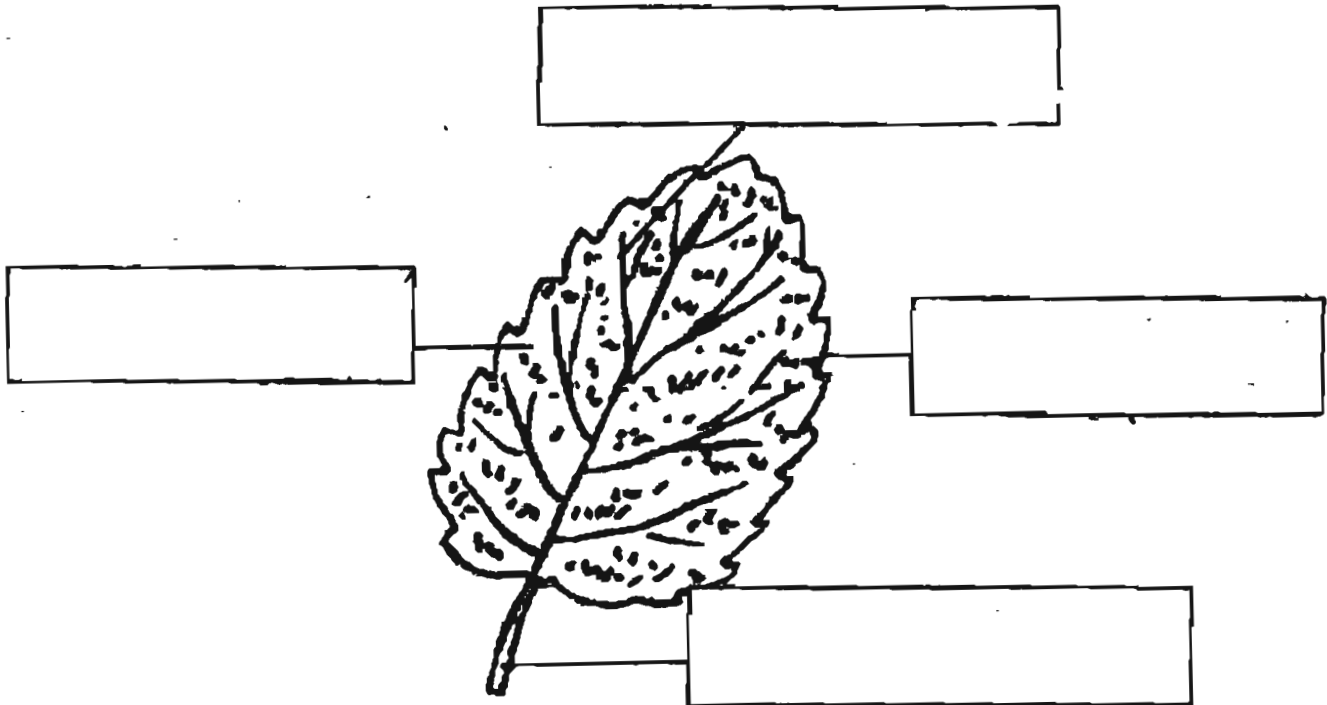

- (b) What is present in the leaf that makes it green in colour? (1 mark)

\_\_\_\_\_

- (c) How does the green pigment in (b) help the plant to make food? (1 mark)

\_\_\_\_\_

\_\_\_\_\_

35. Study the drawings below carefully.



A



B



C



D

(a) Write the letters representing the stages in the life cycle of this plant in the boxes provided. (1 mark)

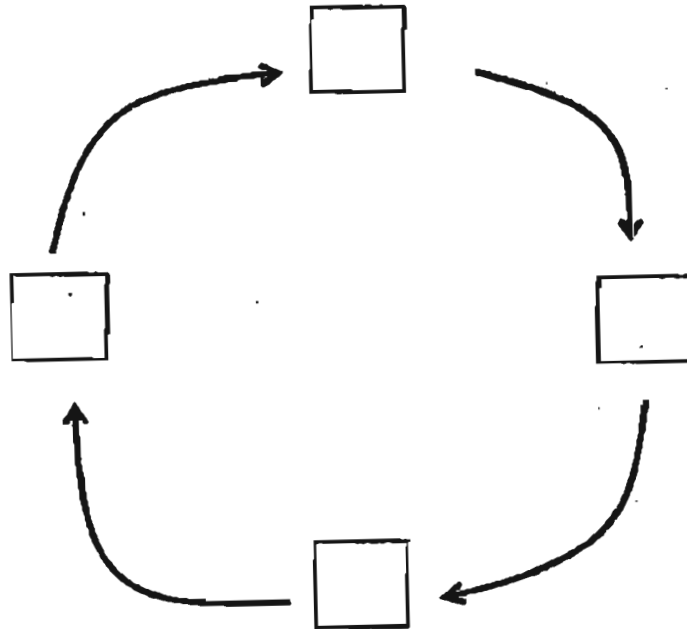

(b) What are the conditions necessary for the germination of this seed? (1 mark)

---

36. Study the different stages of the life-cycle of the butterfly below carefully.

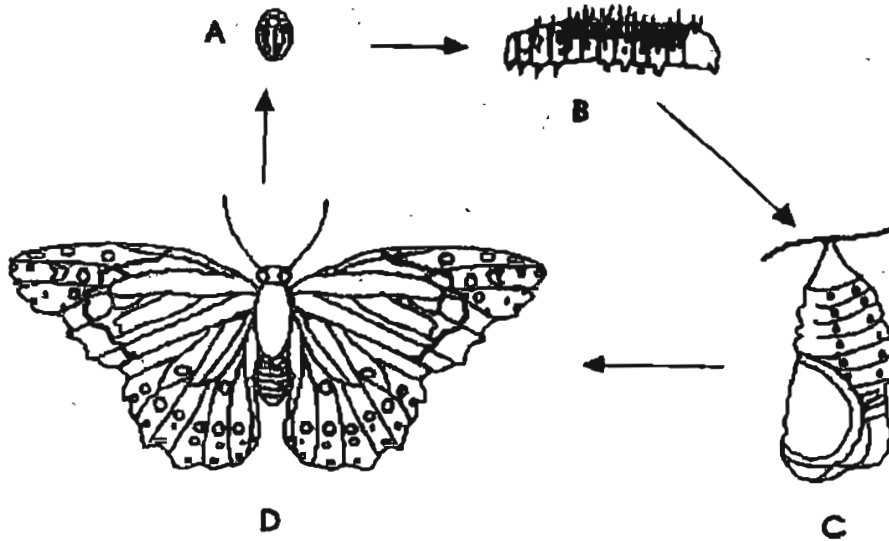

(a) When does the animal moult?

At stage \_\_\_\_\_

(1 mark)

(b) When does the animal not feed at all?

At stage \_\_\_\_\_

(1 mark)



37. Study the drawing of a young seedling below carefully.

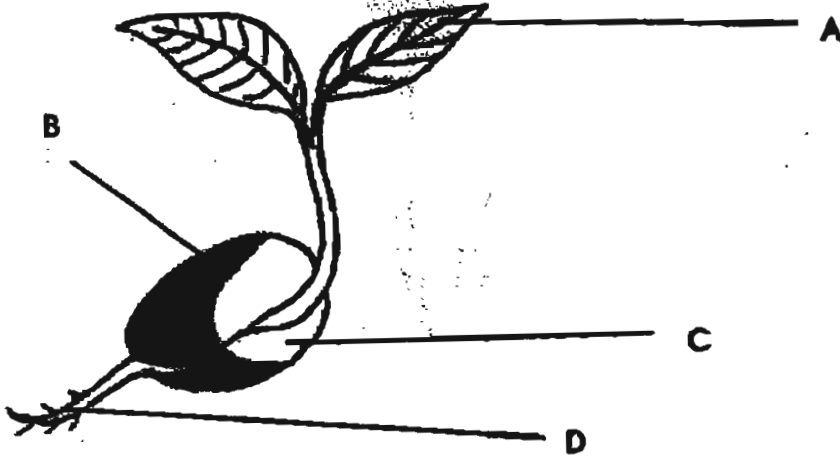

(a) Which part A, B, C or D provides food for the young seedling? (1 mark)

\_\_\_\_\_

(b) State the function of the part marked 'B'. (1 mark)

\_\_\_\_\_

\_\_\_\_\_

38. Study the drawing of a plant below carefully.



(a) Name the part of the plant which helps it to climb up the pole.  
(1 mark)

---

---

(b) State one reason why plants want to climb up a support. (1 mark)

---

---

39. Classify the animals in the table below. (2 marks)

|           |             |          |          |
|-----------|-------------|----------|----------|
| Damselfly | Grasshopper | Ladybird | Housefly |
|-----------|-------------|----------|----------|

| LIFE CYCLE |          |
|------------|----------|
| 3 STAGES   | 4 STAGES |
|            |          |
|            |          |
|            |          |
|            |          |

40. Study the diagram of an arm below carefully.

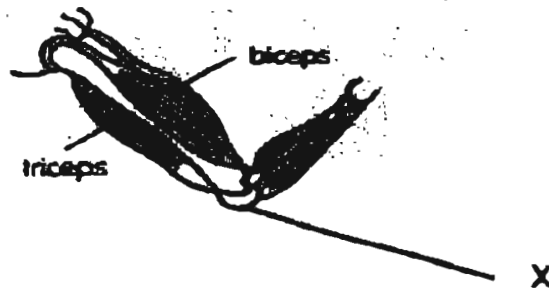

(a) Name the type of joint marked "X". (1 mark)

---

(b) What is the function of "X"? (1 mark)

41. Label the parts (a) and (b) in the diagram below ( 2 marks )

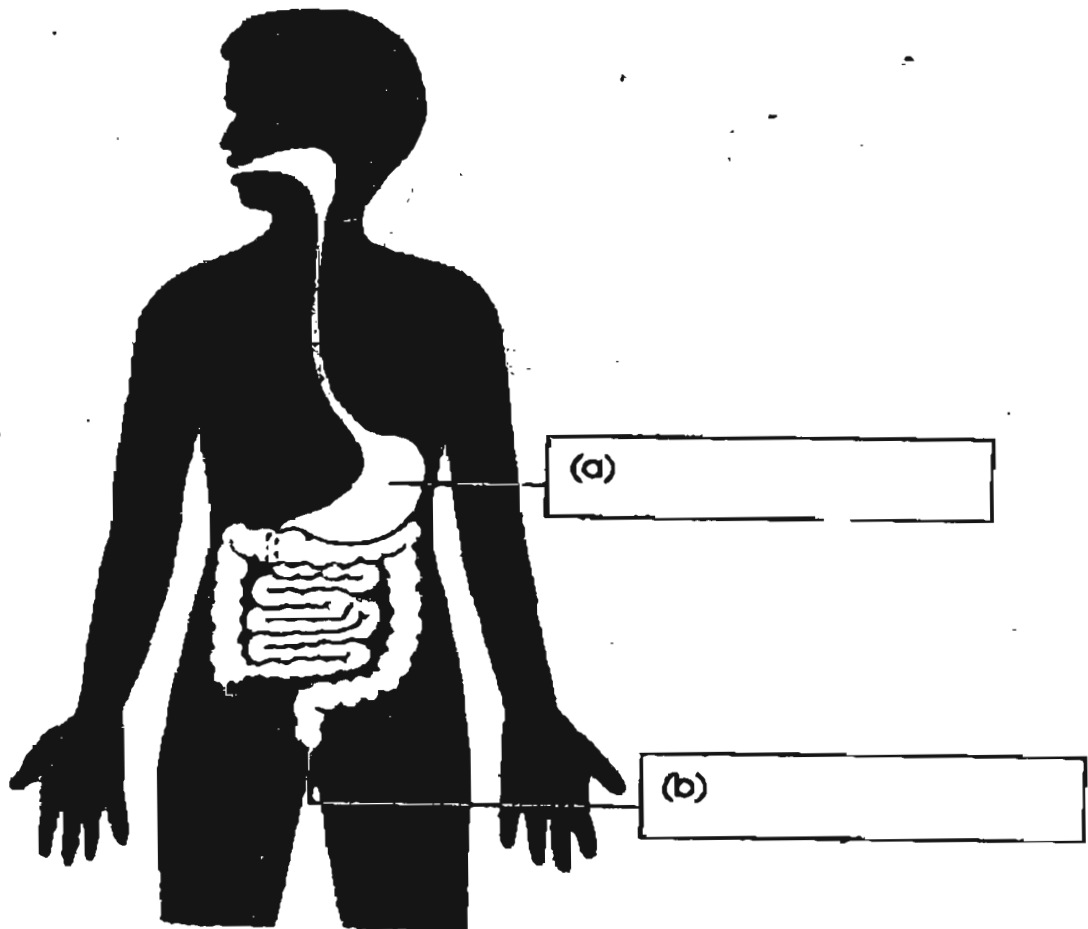

The human digestive system

55

42. Study the drawing of a skeleton below carefully.

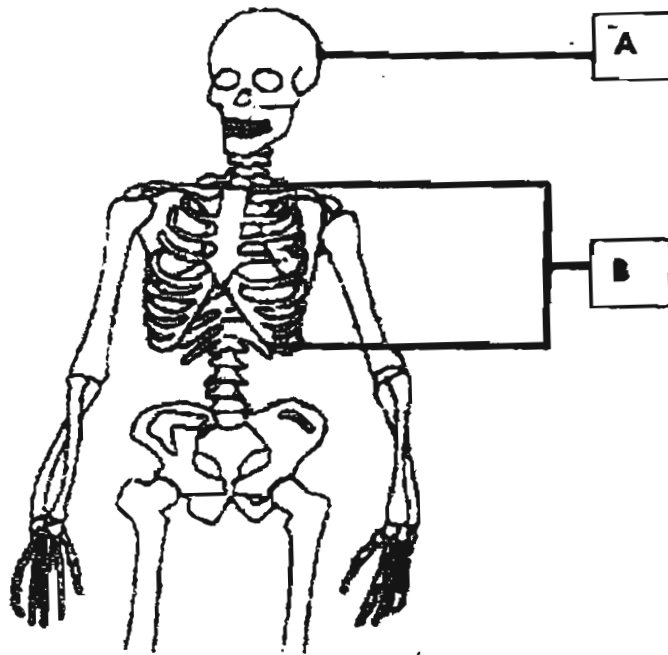

(a) Name the parts A and B. (1 mark)

A : \_\_\_\_\_

B : \_\_\_\_\_

(b) What is the function of "A"? (1 mark)

---

---

(c) What is the function of "B"? (1 mark)

---

---

43. Study the diagram below carefully. Three ring magnets A, B and C are placed together by putting a pencil through the centre of the magnets. It is observed that Ring magnet B "floats" on top of Ring magnet A.

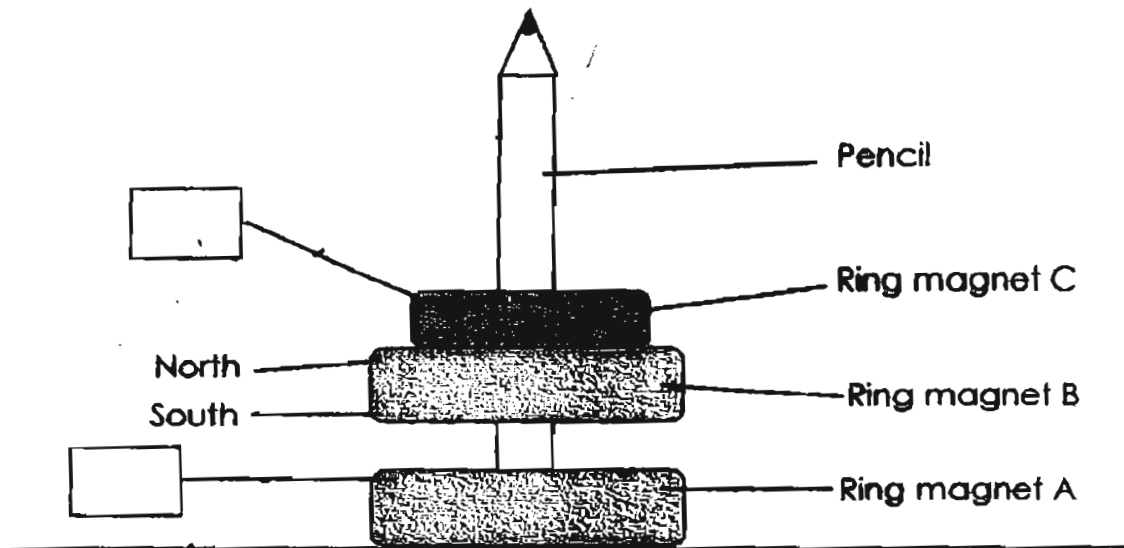

- (a) Using 'N' to represent the north pole and 'S' to represent the south pole of a magnet, label the poles of Ring magnets A and C by writing your answers in the boxes provided. (2 marks)
- (b) What caused Ring magnet B to 'float' on top of Ring magnet A? (2 marks)

---

---

44. Suzie hung 4 materials of the same size on a ruler with identical paper clips. Then she placed the materials in a basin of coloured water. The diagram below shows the results of her experiment after 5 minutes.

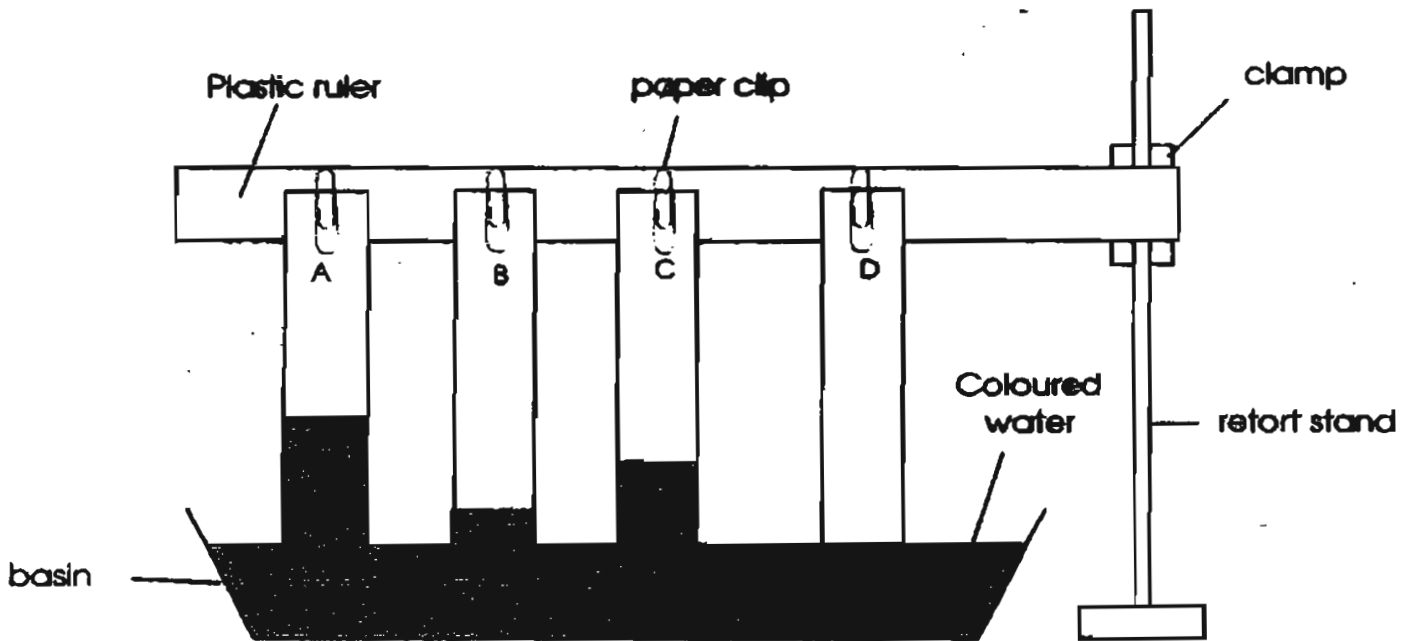

- (a) Arrange the materials from the least absorbent to the most absorbent in the boxes below. (2 marks)

(least absorbent → most absorbent)

- (b) The 4 materials used are tissue paper, cloth, jotter book paper and metal foil. Material A is most likely to be \_\_\_\_\_ and Material D is most likely to be \_\_\_\_\_. (2 marks)

45. Roger classified some food as shown in the classification table below.  
Write down a suitable heading for each group. (2 marks)



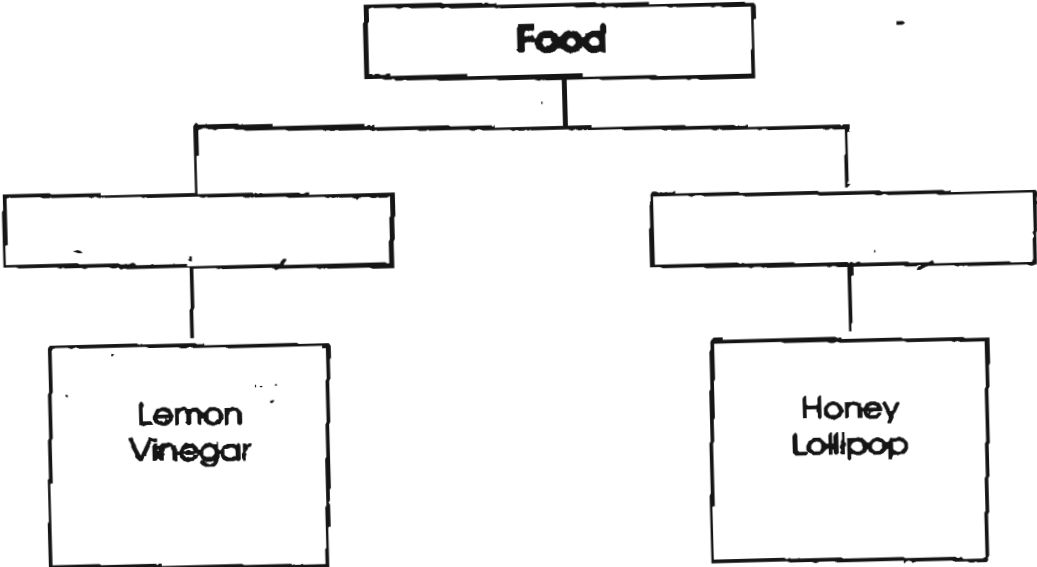

46. Jane and Xinyi made their own magnets by the stroking method. Both of them stroked two similar iron bars with different magnets. Jane's magnetised iron bar could pick up more paper clips than Xinyi's.

(a) State one possible reason for the difference in the strength of their magnetised iron bars. (1 mark)

---

---

(b) State one way in which Xinyi could increase the strength of her magnetised iron bar. (1 mark)

---

---

**End - of - paper**

342

**TAO NAN SCHOOL  
PRIMARY THREE SCIENCE  
END OF THE YEAR EXAMINATION - 2005**

|         |         |           |
|---------|---------|-----------|
| 01. 3   | 11. (3) | 21. 1 (2) |
| 02. 4   | 12. 3   | 22. 3     |
| 03. (1) | 13. 1   | 23. 2     |
| 04. 4   | 14. 1   | 24. 4     |
| 05. 1   | 15. 1   | 25. 2     |
| 06. 4   | 16. 2   | 26. 1     |
| 07. 2   | 17. 2   | 27. 4     |
| 08. (4) | 18. 3   | 28. 2     |
| 09. 2   | 19. 4   | 29. 2     |
| 10. 2   | 20. 2   | 30. 3     |

31) Steel spoon      Plastic ruler  
    Iron nail        Gold ring

32) E            A            B  
    F            D            C

33) a) The celery stalk will turn red.  
    b) The water was carried through the stem.

34) a)            branch vein  
    leaf blade                      leaf edge

leaf stalk

b) Chlorophyll  
c) It traps the sunlight from the sun.

35) a)            D

C                      B

A

b) The conditions are air, water and warmth

36) a) B

b) C

37) a) Part C

b) To protect the seed

38) a) The stem

b) It can reach the sunlight

- 39) Grasshopper      Housefly  
    Damsefly      Ladybird
- 40) a) Hinge joint C  
    b) Allow the elbow to move back and forth.
- 41) a) stomach      b) anus
- 42) a) A : Skull  
    B : ribcage  
    b) Protect the brain  
    c) Protect the lungs and heart
- 43) N  
    S  
    b) Ring Magnet B's south pole and Ring magnet A's south pole are facing each other and like poles repel.
- 44) a) D    B    C    A  
    B) tissue paper  
    metal foil
- 45) Sour      Sweet
- 46) a) Jane's magnet might be stronger than Xinyi's magnet.  
    b) Xinyi could stroke more times.