



# AI TONG SCHOOL

## 2008 SEMESTRAL ASSESSMENT (2) PRIMARY THREE SCIENCE

DURATION : ~~1hr 45 min~~

DATE: 29<sup>th</sup> October 2008

### INSTRUCTIONS

Do not open the booklet until you are told to do so.  
Follow all instructions.  
Answer all questions.

Name : \_\_\_\_\_ ( )

Class : Primary 3 \_\_\_\_\_

Parent's Signature : \_\_\_\_\_

Date : \_\_\_\_\_

Total	100
-------	-----

**Section A (30 x 2 marks)**

For each question from 1 to 30, four options are given. One of them is the correct answer. Make your choice (1, 2, 3 or 4). **Shade the correct oval (1, 2, 3 or 4) on the Optical Answer Sheet.**

1. Which one of the following is a characteristic of plants, but not of animals? They \_\_\_\_\_.

- (1) need air
- (2) need water-
- (3) respond to stimuli
- (4) can make their own food

2. Which of the following are living things?

- A A pebble
- B A seedling
- C A roasted peanut

- (1) A only
- (2) B only
- (3) A and B
- (4) B and C

3. Why do you think there are still living things around even though they can die?

It is because they \_\_\_\_\_.

- (1) need food
- (2) can become ill
- (3) are able to reproduce
- (4) can escape from danger

4. Jane classified some animals into three groups as shown below.

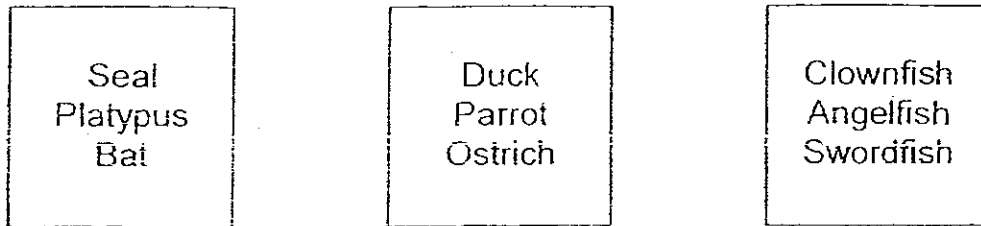

She had classified them according to \_\_\_\_\_.

- (1) the way they reproduce
- (2) their outer coverings
- (3) where they live
- (4) how they move

5. The classification table below shows how some objects are grouped.

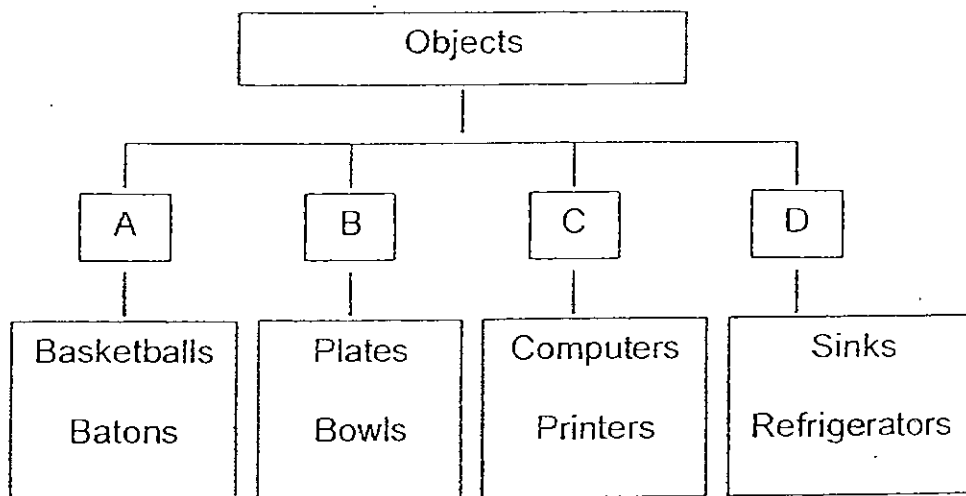

Hoops should be put in Group \_\_\_\_\_.

- (1) A
- (2) B
- (3) C
- (4) D

6. The picture below shows a beetle.

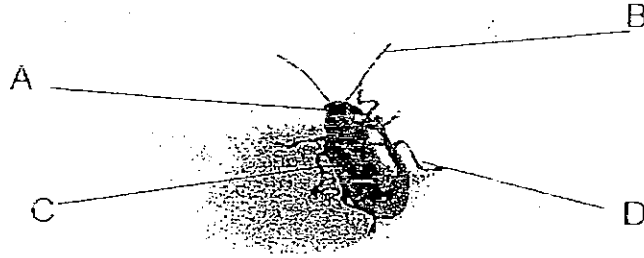

The part labelled \_\_\_\_\_ helps the beetle to feel its way around.

- (1) A
- (2) B
- (3) C
- (4) D

7. Which plant does not produce seeds?

- (1) Fern
- (2) Chilli
- (3) Mango
- (4) Rambutan

8. Which one of the following statements about insects is true?

- (1) All insects have wings.
- (2) All insects have three body parts.
- (3) All insects give birth to their young alive.
- (4) All female insects produce milk for their young.

9. The picture shows a plant.

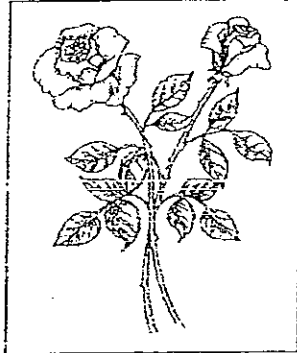

Which of the following statements describe the plant correctly?

- A It is a living thing.
- B It makes its own food.
- C It is a non-flowering plant.

- (1) A and B only
- (2) A and C only
- (3) B and C only
- (4) A, B and C

10. Tiny black spots were formed on a piece of bread as shown in the picture below.

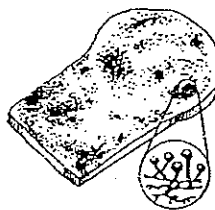

What are the tiny-black spots? They are \_\_\_\_\_.

- (1) plants
- (2) moulds
- (3) mushrooms
- (4) yeasts

11. The table below shows how some objects can be classified. Which of the objects are correctly written in the columns?

Objects made of wood	Objects made of glass	Objects made of fabrics
(1) chopping board	sports shoe	curtain
(2) tooth-pick	marble	dress
(3) watch	door	shirt
(4) ruler	window pane	jar

12. Which of the objects shown below is/are made from materials that were once alive?

A:  a cotton towel

B:  a wooden ruler

C:  a plastic pot

- (1) A only  
 (2) A and B only  
 (3) B and C only  
 (4) A, B and C

13. Mary had to describe the properties of a spectacle frame shown below.

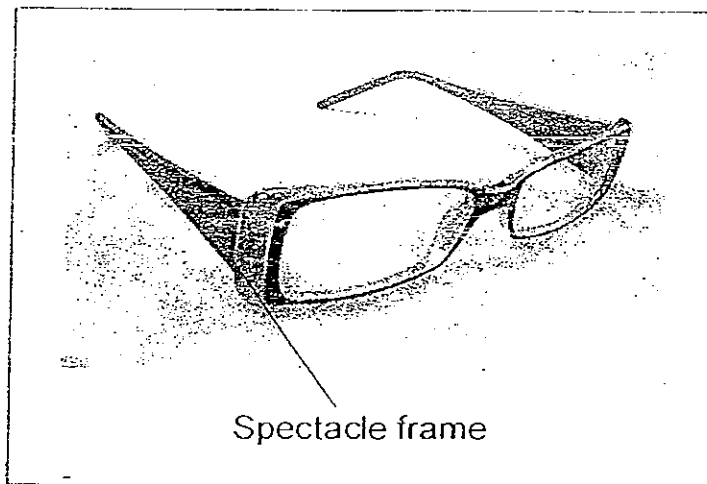

She correctly said that the spectacle frame is \_\_\_\_\_.

- (1) heavy and strong
  - (2) durable and light
  - (3) fragile and light
  - (4) transparent and able to float on water
14. John carried out an experiment to find out the strengths of three types of plastic bags. The results of his experiment are recorded below.

Bag	Number of iron cubes each bag could contain before it broke
A	10
B	8
C	13

Which one of the following statements best describes the plastic bags?

- (1) All the three bags are equally strong.
- (2) Bag B is stronger than Bag A.
- (3) Bag C is the strongest of all.
- (4) Bag A breaks the most easily.

15. It is a hot afternoon. Help Tommy to choose his attire for a walk in the park.

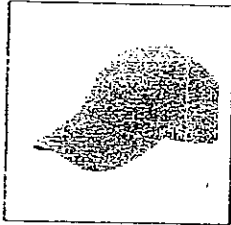

A

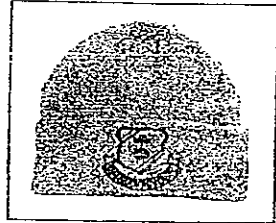

B



C

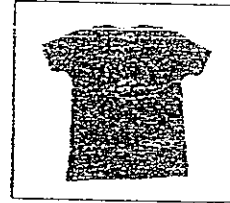

D



E



F



G

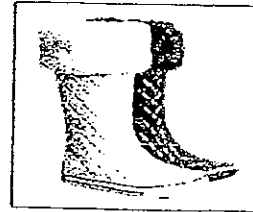

H

The most suitable attire for Tommy is \_\_\_\_\_.

- (1) A, C, E and H
  - (2) A, D, E and G
  - (3) B, C, F and H
  - (4) B, D, F and G
16. Which of the following statements is true about magnets?
- A A freely suspended magnet rests in a north-south direction.
  - B A magnet can be attracted or repelled by another magnet.
  - C The north pole of a magnet will always point to the north.
  - D The strength of a magnet is the same at all parts of a magnet.
- (1) A and C only
  - (2) B and C only
  - (3) B, C and D only
  - (4) A, B and C only



17. Which of the following arrangements will cause the magnets to attract one another ?

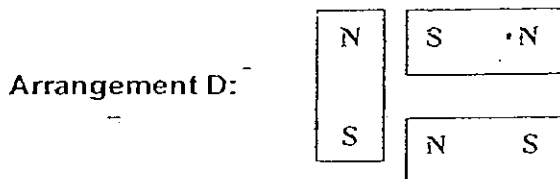
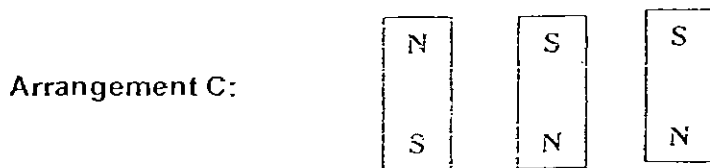
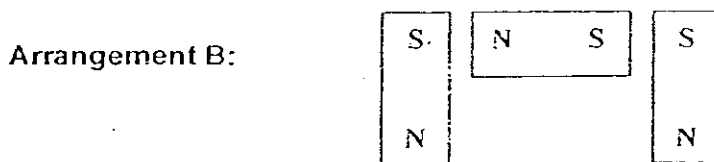
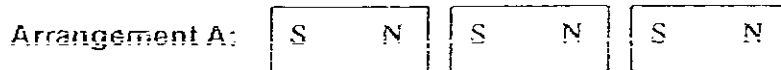

- (1) A only
- (2) A and B only
- (3) A and D only
- (4) C and D only

18. Which of the following objects can be made into a magnet?

- A an eraser
- B an iron nail
- C a steel rod
- D an aluminium can

- (1) A and D only
- (2) B and C only
- (3) B and D only
- (4) B, C and D only

19. Janet set up the experiment as shown in the diagram below. When a magnet was placed below the beaker, it attracted the nail.

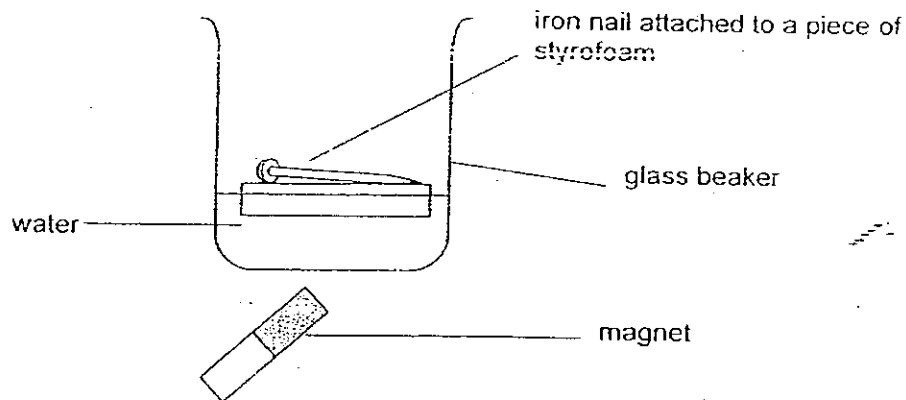

What does this experiment show?

- A The iron nail is a magnet.
- B The iron nail is lighter than the magnet.
- C Magnetic force can attract the styrofoam.
- D Magnetic force can pass through styrofoam, glass and water.

- (1) A only
- (2) D only
- (3) B and C only.
- (4) A and D only

20. In which of these objects can magnets be found ?

- A piano
- B stapler
- C telephone
- D refrigerator

- (1) A and B only
- (2) C and D only
- (3) B, C and D only
- (4) A, C and D only

21. Which one of the following is **not** a function of stems?

- (1) Some stems store food.
- (2) They transport water and food.
- (3) They take in water and mineral salts.
- (4) They hold the branches and leaves upright.

22. All green plants are able to make their own food. The food that they make are carried from \_\_\_\_\_.

- (1) the roots to the leaves only
- (2) the leaves to the stems only
- (3) the roots to other parts of the plant
- (4) the leaves to other parts of the plant

23. Jenny collected two leaves from the garden and made a sketch of them as shown below.

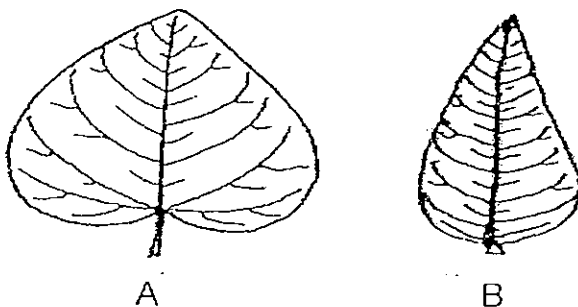

How are Leaf A and Leaf B similar?

- (1) They are oval-shaped.
- (2) They have no leaf veins.
- (3) They have entire edges.
- (4) Their leaf stalks are of the same length.

24. Which of the following statements about plants are true?

- A All leaves have leaf blades.
- B Some stems store food for the plant.
- C Fruits are developed from the flowers of plants.
- D Flowers may differ in size and colour but they are all sweet smelling.

- (1) A and C only
- (2) B and D only
- (3) A, B and C only
- (4) A, C and D only

25. The picture below shows some plants that we eat.

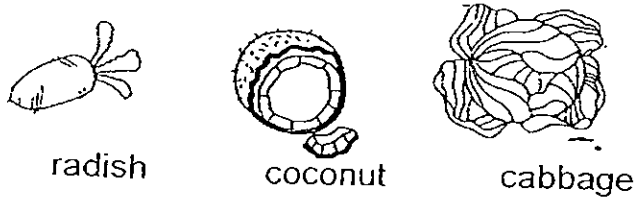

Which of the following show correctly the part of these plants that we eat?

	radish	coconut	cabbage
(1)	fruit	stem	leaf
(2)	stem	root	leaf
(3)	root	fruit	leaf
(4)	root	fruit	stem

26. The diagram below shows the young of an animal.  
It will grow into a \_\_\_\_\_.

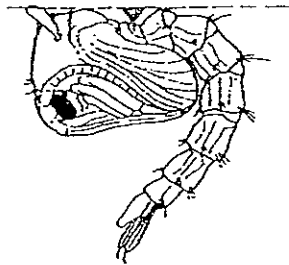

- (1) moth
- (2) housefly
- (3) mosquito
- (4) butterfly

27. Look at the three animals below.

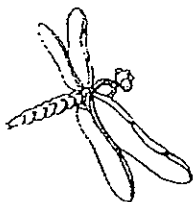

dragonfly

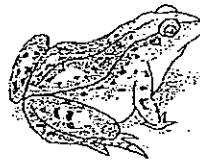

frog



mosquito

In what way are they alike?

- (1) They lay their eggs in water.
- (2) They take care of their young.
- (3) Their eggs are covered with jelly.
- (4) They undergo a three stage life cycle.

28. Study the classification table below.

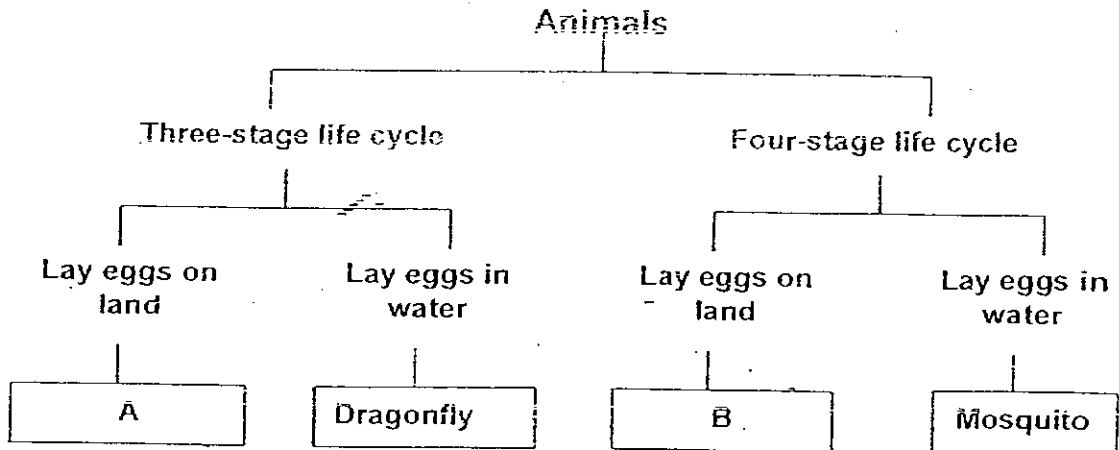

What can Animals A and B be?

	A	B
(1)	Frog	Chicken
(2)	Beetle	Ant
(3)	Toad	Housefly
(4)	Grasshopper	Butterfly

29. Which one of the following pairs of animals has life cycles similar to the one shown below?

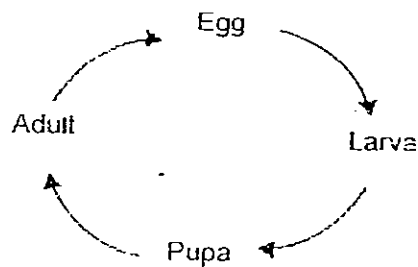

- (1) moth and mealworm beetle
- (2) grasshopper and beetle
- (3) butterfly and dragonfly
- (4) mosquito and cockroach

30. The picture below shows a caterpillar.

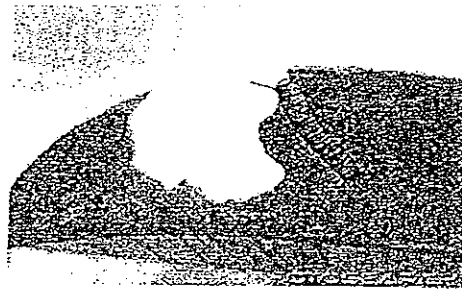

Which of the following statements about caterpillars are true?

- A They can moult.
- B They feed on leaves.
- C They change into pupae.
- D They are the young of beetles.

- (1) B and D only
- (2) B and C only
- (3) A, B and C only
- (4) A, C and D only

Name: \_\_\_\_\_ ( )

Class: \_\_\_\_\_

**Section B: (20 marks)**

**Fill in the blanks with the correct answers. Use each word ONCE only.**

pupa	male	nymph	properties	fabrics
gills	roots	bark	attract	repel
permanent	stem	female	larva	temporary

31. A mealworm is the \_\_\_\_\_ of a beetle.
32. The \_\_\_\_\_ mammal produces milk to feed its young.
33. There are many types of materials. Knowing the \_\_\_\_\_ of a type of material can help us decide how it can be used.
34. \_\_\_\_\_ are flexible. They are used to make clothes, bags and towels.
35. The young of a grasshopper is called a \_\_\_\_\_

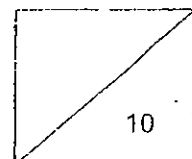



36. The tadpole breathes through its \_\_\_\_\_.
37. Food can be stored in the \_\_\_\_\_ of carrot and turnip plants.
38. When the north pole of a magnet is placed near the south pole of another magnet, the two poles \_\_\_\_\_ each other.
- 39.- Magnets which lose their magnetism after a very short time are called \_\_\_\_\_ magnets.
40. The outer covering of the tree trunk is the \_\_\_\_\_.

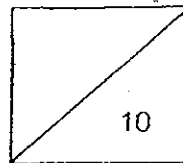

**Section C: (20 marks)**

**Write your answers to questions 41 to 45 in the spaces provided.**

41. Joy went to the zoo and took a photograph of an animal as shown below. She noticed that this animal could swim but could not fly. She thought it was a fish. Her teacher said that she had classified the animal wrongly. Her teacher was right.

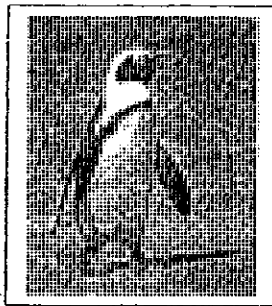

- (a) Which group should this animal be classified under?

\_\_\_\_\_ [1]

- (b) State 2 characteristics that only this group of animals has.

(i) \_\_\_\_\_ [1]

(ii) \_\_\_\_\_ [1]

- (c) Name another animal which belongs to this group.

\_\_\_\_\_ [1]

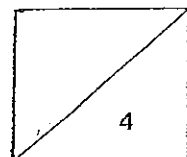

42. Look at the parts that make up an umbrella.

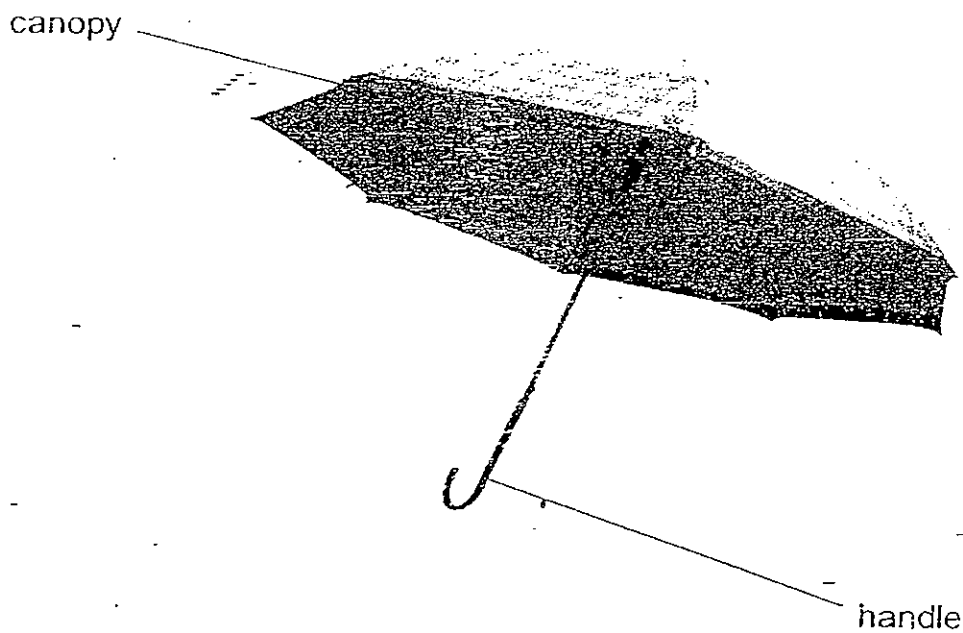

(a) (i) What material is used to make the handle?

\_\_\_\_\_ [1]

(ii) Write down one property of the material used to make the handle.

\_\_\_\_\_ [1]

(b) (i) What material is used to make the canopy so that it is waterproof?

\_\_\_\_\_ [1]

(ii) Write down one other property of the material that is used to make the canopy.

\_\_\_\_\_ [1]

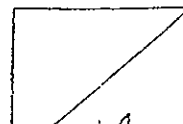

43. The diagram below represents the life cycle of a cockroach.

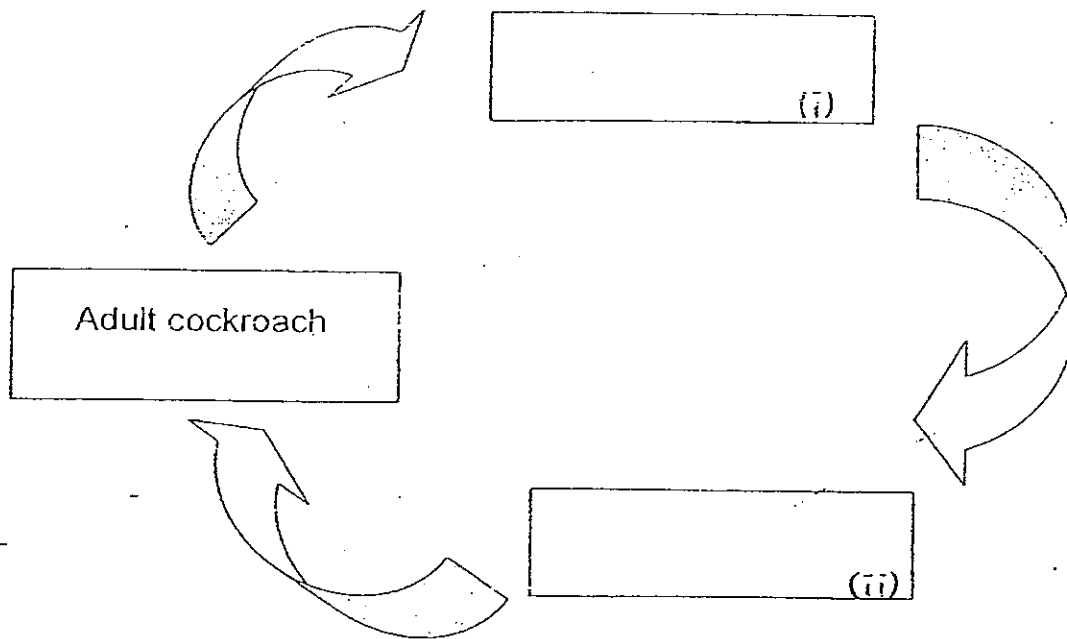

(a) Fill in the boxes with the correct stages of growth of the cockroach. [2]

(b) Name two similarities between the life cycle of cockroach and that of a grasshopper.

(i) \_\_\_\_\_ [1]

(ii) \_\_\_\_\_ [1]

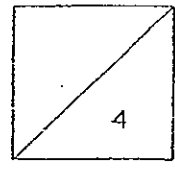

44. The diagram below shows a balsam plant.

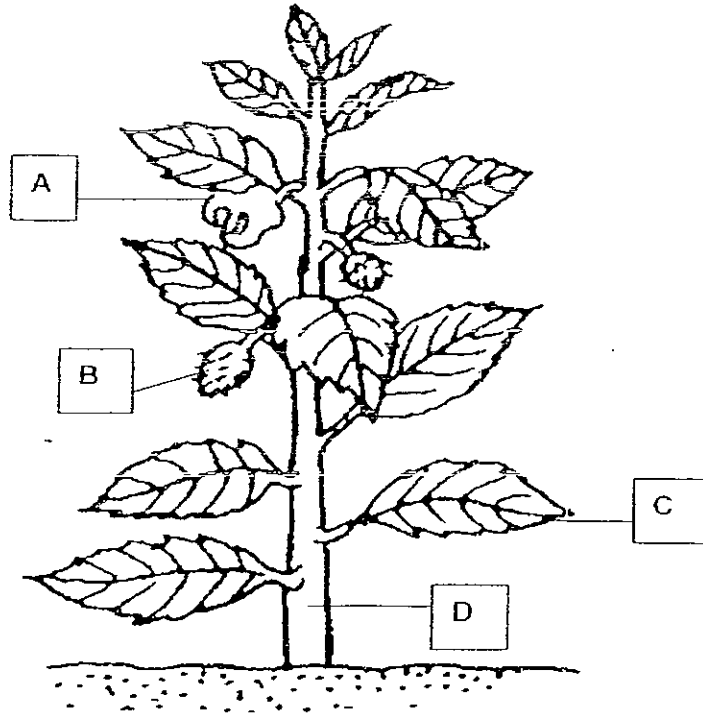

(a) Name the parts labelled A, B, C and D. [2]

A	
B	
C	
D	

(b) One part of this plant cannot be seen in the picture.

What is the part that cannot be seen? \_\_\_\_\_ [1]

(c) Why will the plant not survive if this part is missing?

\_\_\_\_\_ [1]

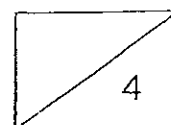

45. The table below shows 3 objects and how they interact when placed near a magnet.

Object \ Observations	A	B	C
Attracted by magnet	Yes	Yes	No
Interaction	Yes	Yes	No
Repelled by magnet	No	Yes	No

(a) By referring to the observations in the table, write down A, B, or C to match each object.

Staple: \_\_\_\_\_ [1]

Magnet: \_\_\_\_\_ [1]

(b) Name the two kinds of magnets shown below.

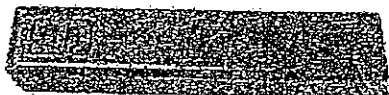

\_\_\_\_\_ [1]

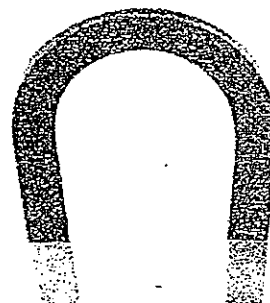

\_\_\_\_\_ [1]

End-of-Paper

Please Check Your Work

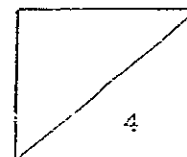

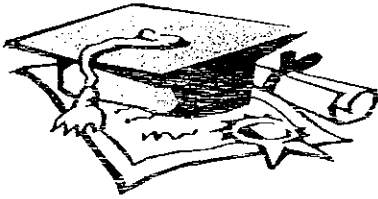

# ANSWER SHEET

EXAM PAPER 2008

SCHOOL : AITONG PRIMARY SCHOOL  
SUBJECT : PRIMARY 3 SCIENCE

TERM : SA 2

Q1	Q2	Q3	Q4	Q5	Q6	Q7	Q8	Q9	Q10	Q11	Q12	Q13	Q14	Q15	Q16	Q17
4	2	3	2	1	2	1	2	1	2	2	2	2	3	2	4	3

Q18	Q19	Q20	Q21	Q22	Q23	Q24	Q25	Q26	Q27	Q28	Q29	Q30
2	2	3	3	4	3	3	3	3	1	4	1	3

31)larva      32)female      33)properties      34)Fabrics

35)nymph      36)gills      37)roots      38)attract

39)temporary      40)bark

41)a)This animal should group under birds.  
b)i)It has a beak.      ii)It has feathers.  
c)It is hen.

42)a)i) It is plastic.      ii)It is durable.  
b)i)It is plastic.      ii)Plastic is light.

43)a)i)eggs      ii)nymph  
b)i)The cockroach and grasshopper have 3 stages in its life cycle.  
ii)The young look like it parents.

44)a)A: flower    B: fruit    C: leaf    D: stem  
b)roots.

c)The plant cannot make food without roots because the roots take in water and minerals salt.

45)a)Staple: A                      Magnet: B  
b)bar magnet                      horseshoe magnet