



# RED SWASTIKA SCHOOL

## 2016 SEMESTRAL ASSESSMENT 2

### MATHEMATICS

Name : \_\_\_\_\_ . (     )

Class : Primary 4 / \_\_\_\_\_

Date : 26 October 2016

### BOOKLET A

20 Questions

40 Marks

Duration of Paper : 1 hour 45 minutes

**Note:**

1. Do not open this Booklet until you are told to do so.
2. Read carefully the instructions given at the beginning of each part of the Booklet.
3. Do not waste time. If a question is difficult for you, go on to the next one.
4. Check your answers thoroughly and make sure you attempt every question.
5. In this booklet, you should have the following:
  - (a) Page 1 to Page 6
  - (b) Questions 1 to 20

Questions 1 to 20 carry 2 marks each. For each question, four options are given. One of them is the correct answer. Make your choice (1, 2, 3 or 4). Shade the correct oval (1, 2, 3 or 4) on the Optical Answer Sheet.

(40 marks)

- 
- 1     33 thousands and 9 tens is the same as \_\_\_\_\_.
- (1) 339
  - (2) 3 390
  - (3) 33 009
  - (4) 33 090
- 2     Which of the following is a factor of both 18 and 24?
- (1) 6
  - (2) 8
  - (3) 9
  - (4) 12
- 3     How many one-fifths are there in 2 wholes?
- (1)  $2\frac{1}{2}$
  - (2)  $\frac{2}{5}$
  - (3) 5
  - (4) 10
- 4     Find the value of  $\frac{7}{12} - \frac{1}{4}$
- (1)  $\frac{1}{2}$
  - (2)  $\frac{2}{3}$
  - (3)  $\frac{1}{3}$
  - (4)  $\frac{3}{4}$

- 5 In the figure below, which angle is greater than a right angle?

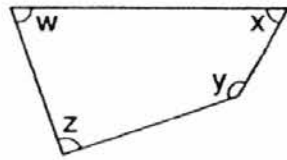

- (1)  $\angle w$   
(2)  $\angle x$   
(3)  $\angle y$   
(4)  $\angle z$
- 6 Write  $6\frac{3}{20}$  as a decimal.
- (1) 6.32  
(2) 6.3  
(3) 6.15  
(4) 6.015
- 7 Mrs Lam had 3 boxes of candies. There were 570 candies in each box. She repacked them into small packs of 6 candies each. How many small packs of candies did she have?
- (1) 95  
(2) 190  
(3) 285  
(4) 561
- 8 The table below shows the number of broken eggs in each tray.

Number of broken eggs in a tray	0	1	2	3	4
Number of trays	45	30	10	8	5

How many trays contain at least 2 broken eggs?

- (1) 10  
(2) 13  
(3) 18  
(4) 23

- 9 The figure below is made up of a square ABCD and a rectangle EFGC. Find the length of BE.

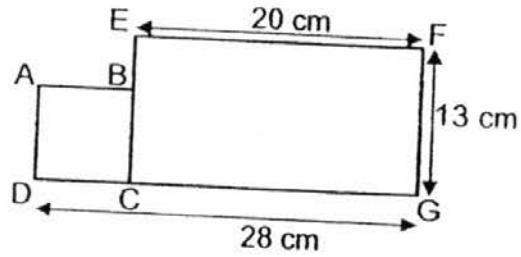

- (1) 5 cm
- (2) 7 cm
- (3) 8 cm
- (4) 12 cm

- 10 Which two figures have the same area but different perimeter?

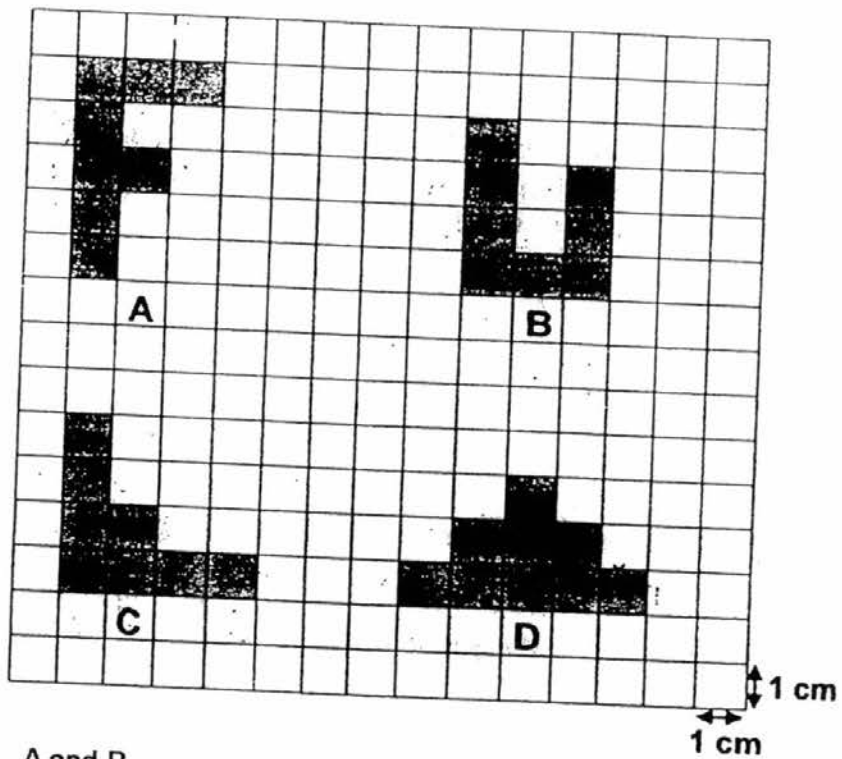

- (1) A and B
- (2) A and C
- (3) B and D
- (4) C and D

- 11 Find the perimeter of the figure shown below.

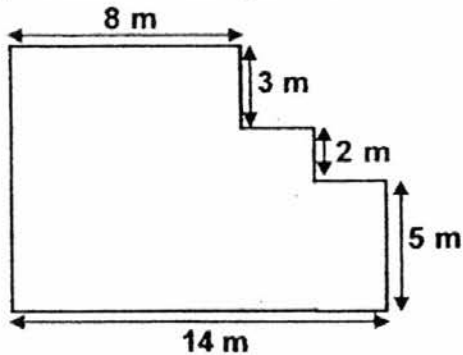

- (1) 32 m  
(2) 42 m  
(3) 48 m  
(4) 50 m
- 12 What is the difference between A and B in the number line shown?

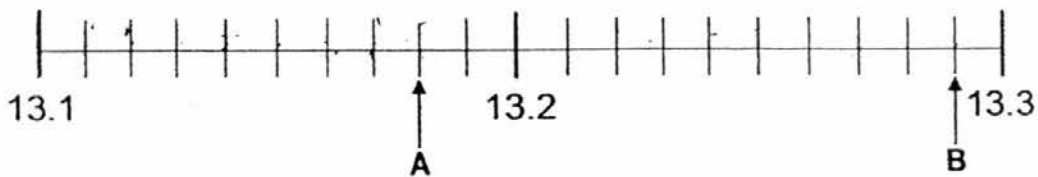

- (1) 0.01  
(2) 0.09  
(3) 0.11  
(4) 0.9
- 13 Teck Wee had \$5.00. He bought a pen with a two-dollar note, 4 twenty-cent coins and 3 five-cent coins. How much did he have left?
- (1) \$2.05  
(2) \$2.15  
(3) \$2.95  
(4) \$3.95
- 14 A movie ended at 00 15 the next day. Given that the duration of the movie was 2h 20 min, at what time did the movie start?
- (1) 2.35 a.m.  
(2) 2.35 p.m.  
(3) 9.55 a.m.  
(4) 9.55 p.m.

15 Which one of the following figures does not have a line of symmetry?

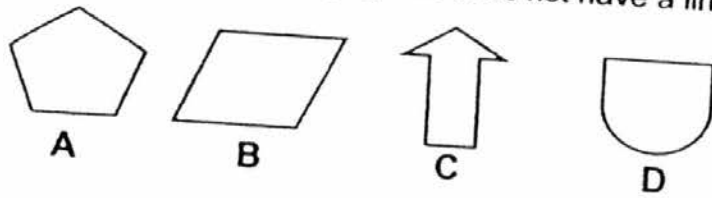

- (1) A
- (2) B
- (3) C
- (4) D

16 Mark was at point X facing the food centre. He wanted to go to the library. In which direction should he turn?

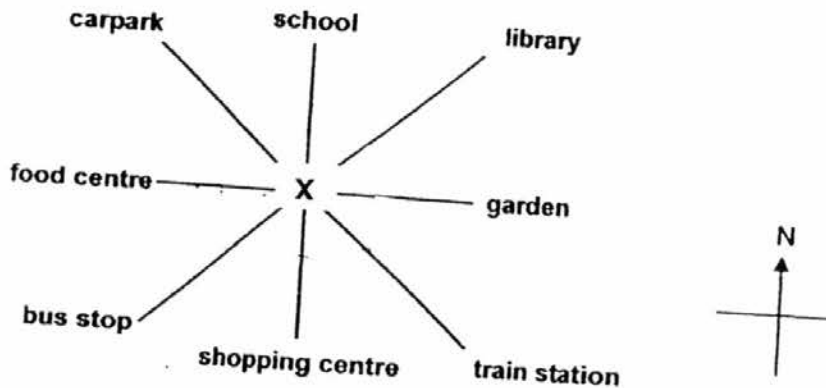

- (1)  $45^\circ$  clockwise
- (2)  $135^\circ$  anti-clockwise
- (3)  $225^\circ$  anti-clockwise
- (4)  $315^\circ$  clockwise

17 The figure below, not drawn to scale, shows a square ABCD and a rectangle EFGC. Find  $\angle x + \angle y$ .

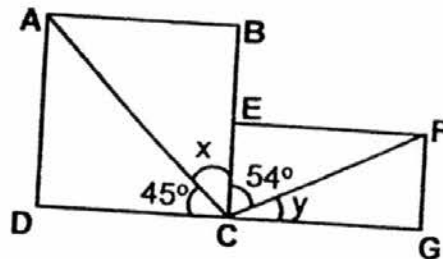

- (1)  $36^\circ$
- (2)  $81^\circ$
- (3)  $99^\circ$
- (4)  $119^\circ$

- 18 Rajah took a quiz. For every correct answer, he was awarded 5 points. For every wrong answer, 3 points were deducted. 4 out of the 20 questions he answered were wrong. How many points did he score?
- (1) 20
  - (2) 60
  - (3) 68
  - (4) 88
- 19 Apples are sold in packets of 8. Mrs Tan wants to give 3 apples to every elderly in her neighbourhood. There are 45 elderly in all. How many packets of apples should she buy?
- (1) 11
  - (2) 12
  - (3) 16
  - (4) 17
- 20 Mr Smith boarded a plane at 9.45 p.m. He reached his destination at 5.20 a.m. How long was his journey?
- (1) 4 h 25 min
  - (2) 7 h 35 min
  - (3) 14 h 25 min
  - (4) 15 h 05 min



# RED SWASTIKA SCHOOL

## 2016 SEMESTRAL ASSESSMENT 2

### MATHEMATICS

Name : \_\_\_\_\_ ( )

Class : Primary 4 , \_\_\_\_\_

Date : 26 October 2016

### BOOKLET B

28 Questions

60 Marks

In this booklet, you should have the following:

(a) Page 7 to Page 17

(b) Questions 21 to 48

### MARKS

	OBTAINED	POSSIBLE
BOOKLET A		40
BOOKLET B		60
TOTAL		100



Questions 21 to 30 carry 1 mark each. Questions 31 to 40 carry 2 marks each. Show your working clearly in the space below each question and write your answers in the spaces provided. For questions which require units, give your answers in the units stated.

(30 marks)

- 21 Find the sum of the first two common multiples of 4 and 6.

Ans: \_\_\_\_\_

- 22 Bala went to a school concert. The concert started at 19 00. Every performance item lasted for 20 minutes. There was a 5 minute break after the 3<sup>rd</sup> item. What time would the 4<sup>th</sup> item start?

Ans: \_\_\_\_\_

- 23 Ali was standing at point O and facing a certain direction. He made a  $\frac{3}{4}$  - turn in the anti-clockwise direction. Then, he made a  $\frac{1}{2}$  - turn in the clockwise direction. He realised that he was facing North-West in the end. Which direction was he facing at first?

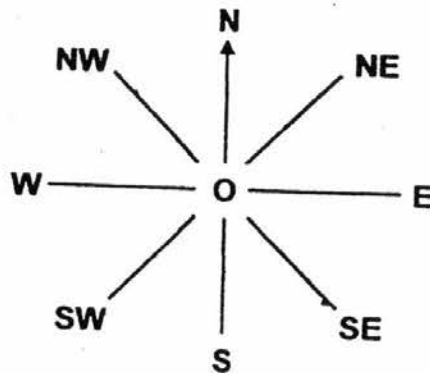

Ans: \_\_\_\_\_

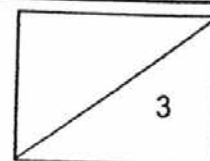

The bar graph below shows the number of stamps collected by four boys. Study the graph carefully and use it to answer **Questions 24 to 27**.

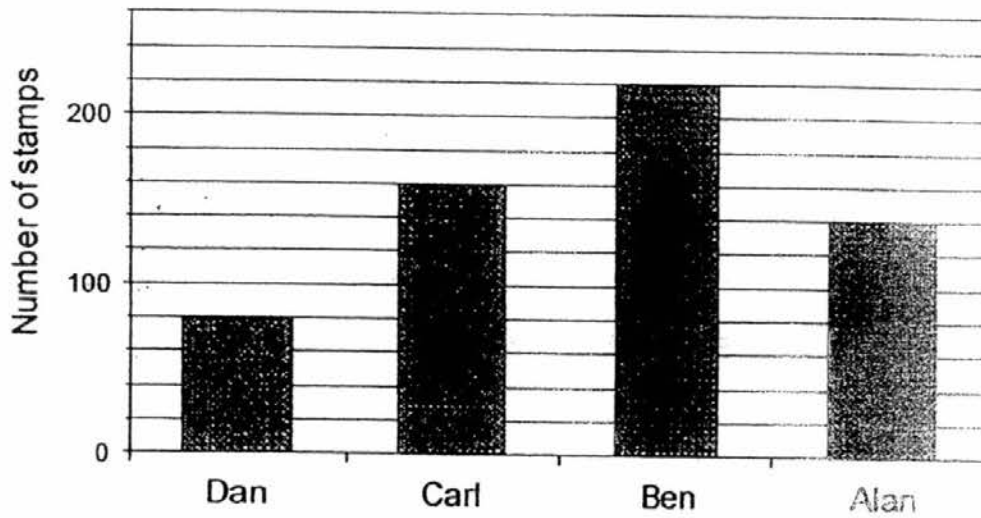

24 Which boy collected half as many stamps as Carl?

Ans: \_\_\_\_\_

25 How many stamps did the four boys collect altogether?

Ans: \_\_\_\_\_

26 How many stamps must Ben give Alan so that they have the same number of stamps?

Ans: \_\_\_\_\_

- 27 Dan wanted to raise \$500 for charity. If he sold all his stamps at \$4 each, how many more stamps must he collect?

Ans: \_\_\_\_\_

- 28 The perimeter of the rectangle is 42 cm. Find its area.

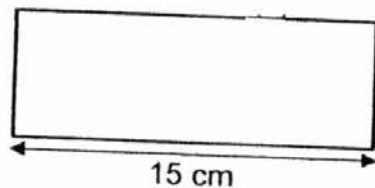

Ans: \_\_\_\_\_ cm<sup>2</sup>

- 29 Peter painted a logo for his company on a square board ABCD as shown. Find the area of the shaded parts of the logo.

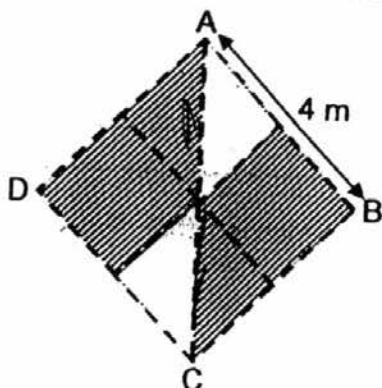

Ans: \_\_\_\_\_ m<sup>2</sup>

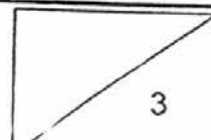

- 30 The figure below shows a rectangle ABCD. It contains rectangle ABYX and 3 similar squares. Find the area of rectangle ABCD.

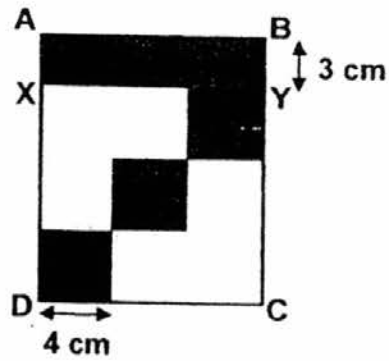

Ans: \_\_\_\_\_ cm<sup>2</sup>

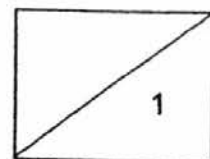

31 Write seventeen thousand and eighty-two in figures.

Ans: \_\_\_\_\_

32 Write the missing number in the number pattern below.

2 639 , 2 789 , 2 939 , \_\_\_\_\_ , 3 239

Ans: \_\_\_\_\_

33 Round off 63 410 to the nearest hundred.

Ans: \_\_\_\_\_

34 Arrange the following fractions from the greatest to the smallest.

$$\frac{1}{2} , \frac{3}{4} , \frac{5}{12}$$

Ans: \_\_\_\_\_ , \_\_\_\_\_ , \_\_\_\_\_  
(greatest) (smallest)

35 What is the value of  $\frac{5}{8} + \frac{3}{4}$ ?  
Express your answer as a mixed number.

Ans: \_\_\_\_\_

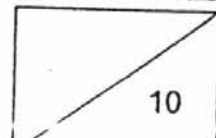

- 36 The figure below, not drawn to scale, shows a rectangle ABCD. Find the value of  $\angle x$ .

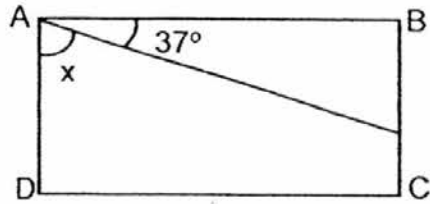

Ans: \_\_\_\_\_°

---

- 37 What is the missing number in the box?

$$0.7 = \frac{7}{\boxed{?}}$$

Ans: \_\_\_\_\_

---

- 38  $8.4 - 0.93 =$  \_\_\_\_\_

Ans: \_\_\_\_\_

---

- 39 Find the value of  $7.83 \times 6$ .

Ans: \_\_\_\_\_

---

- 40 Shade two more unit squares to make the figure symmetrical. Line AB is the line of symmetry.

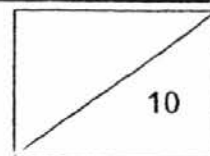
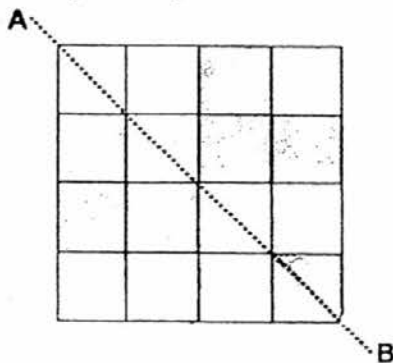

Questions 41 to 48 carry 3 or 4 marks each. Show your working clearly in the space below each question and write your answers in the spaces provided.  
(30 marks)

---

- 41 Maria needed to mix some red paint and white paint to get pink paint. She mixed 5.23 l of red paint and 3 times as much white paint into a container. After mixing, she poured the pink mixture equally into 5 tins. How much pink paint was there in 1 tin? Round off your answer to 2 decimal places.

Ans: \_\_\_\_\_ [4]

---

- 42 Mdm Sim spent a total of \$116.50 on a bolster and 6 identical pillows. A bolster cost \$1.80 less than a pillow. How much did she pay for a pillow?

Ans: \_\_\_\_\_ [4]

---

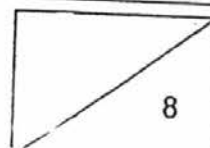

- 43 The line graph below shows the distance from Josh's house during his walk.

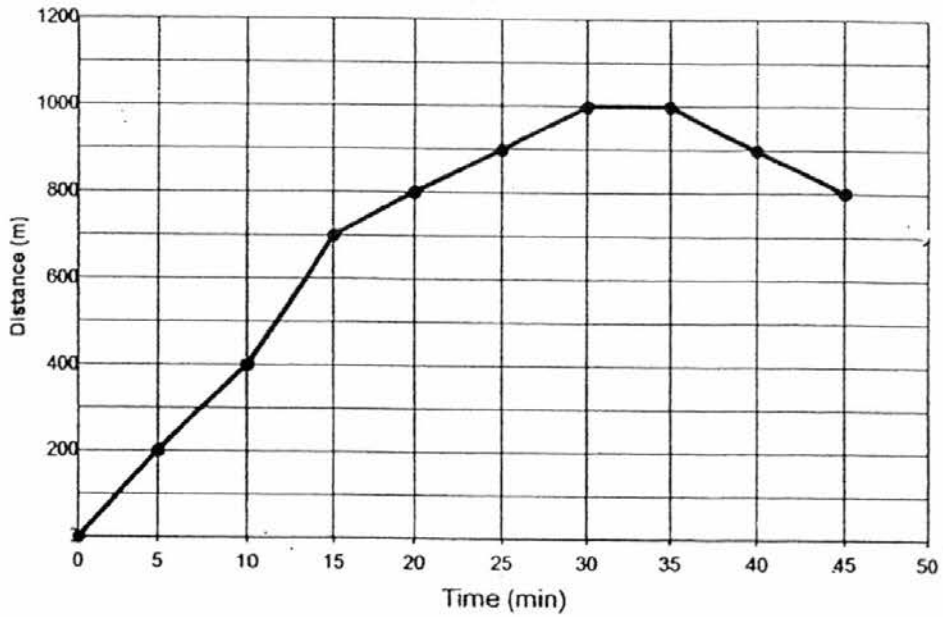

- (a) What was the increase in distance from Josh's house from the 5<sup>th</sup> to the 20<sup>th</sup> minute? (2m)
- (b) Josh was 700 m away from his house at the 50<sup>th</sup> minute. Mark a cross (X) on the line graph above to show the distance from Josh's house at the 50<sup>th</sup> minute. (2m)

Ans: (a) \_\_\_\_\_ [2]

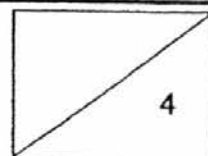



- 44 Mrs Devi needs 5 m of ribbon to decorate a Christmas tree and two similar gifts. For each gift, she needs  $\frac{7}{9}$  m of ribbon. How much ribbon will she need to decorate the Christmas tree? Express your answer as a mixed number.

Ans: \_\_\_\_\_ [3]

---

- 45 Mr Wee had 238 durians. He sold  $\frac{2}{7}$  of them and shared the rest equally among his 10 neighbours. How many durians did each neighbour get?

Ans: \_\_\_\_\_ [4]

---

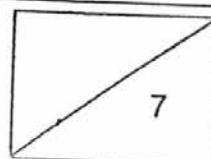

46 Bob has 228 red and green marbles. He has five times as many red marbles as green marbles.

- (a) How many red marbles does Bob have?
- (b) How many more green marbles should he buy so that he has half as many green marbles as red marbles?

Ans: (a) \_\_\_\_\_ [2]

Ans: (b) \_\_\_\_\_ [2]

---

47 During a sale, 1 shirt and 1 tie cost \$187. Mrs Goh bought 4 shirts and 3 ties for \$710. How much did she pay for a tie?

Ans: \_\_\_\_\_ [4]

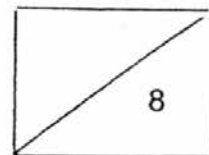

- 48 The figure below is made up of identical rectangles. The length of the rectangle is twice of its breadth. The area of the figure is  $256 \text{ cm}^2$ . What is the perimeter of the figure?

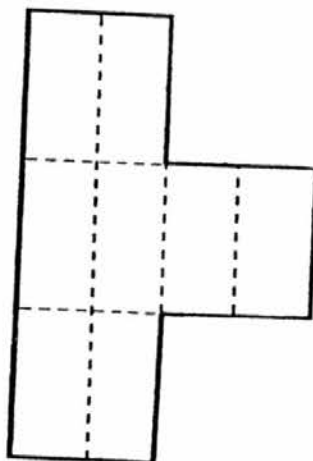

Ans: \_\_\_\_\_ [3]

---

End of Paper

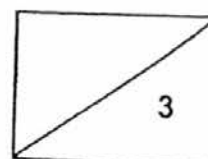

YEAR : 2016  
 LEVEL : PRIMARY 4  
 SCHOOL : RED SWASTIKA  
 SUBJECT : MATHEMATICS  
 TERM : SA2

Booklet A

Q1	Q2	Q3	Q4	Q5	Q6	Q7	Q8	Q9	Q10
4	1	4	3	3	3	3	4	1	2
Q11	Q12	Q13	Q14	Q15	Q16	Q17	Q18	Q19	Q20
3	3	1	4	2	3	2	3	4	2

Booklet B

- Q21 Multiples of 4  $\rightarrow$   $\overbrace{8, 12, 16, 20, 24, 28, 32, 36, 40}^{12 \text{ \& } 24}$   
 Multiples of 6  $\rightarrow$   $\overbrace{6, 12, 18, 24, 30, 36, 42, 48, 54, 60}^{12 \text{ \& } 24}$   
 $12 + 24 \Rightarrow \underline{36}$
- Q22 20 05  
 Q23 North-East  
 Q24 Dan  
 Q25 600 stamps  
 Q26 40 stamps  
 Q27 45 more stamps  
 Q28  $90 \text{ cm}^2$   
 Q29  $12 \text{ m}^2$   
 Q30  $8 + 4 = 12$   
 $12 + 3 = 15$   
 $12 \times 15 \Rightarrow \underline{180 \text{ cm}^2}$
- Q31 17 082

- Q32      3 089
- Q33      63 400
- Q34       $\frac{3}{4}, \frac{1}{2}, \frac{5}{12}$
- Q35       $1\frac{3}{8}$
- Q36       $53^\circ$
- Q37      10
- Q38      7.47
- Q39      46.98
- Q40

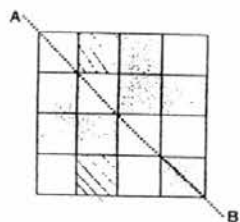

- Q41       $5.23 \times 3 = 15.69$   
 $15.69 + 5.23 = 20.92$   
 $20.92 \div 5 = 4.184 \approx \underline{4.18 \text{ } \ell}$

- Q42       $116.50 + 1.80 = 118.30$   
 $118.30 \div 7 \Rightarrow \underline{\$16.90}$

- Q43      (a)  $800 - 200 \Rightarrow \underline{600 \text{ m}}$

(b)

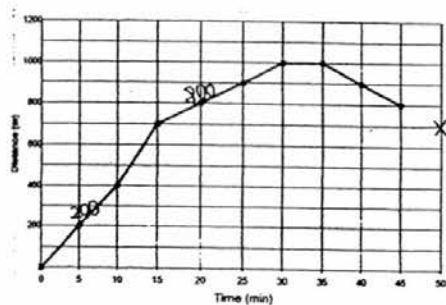

Q44  $\frac{7}{9} + \frac{7}{9} = \frac{14}{9} \rightarrow 1\frac{5}{9}$   
 $5\text{ m} - 1\frac{5}{9}\text{ m} \Rightarrow 3\frac{4}{9}\text{ m}$

Q45  $238 \div 7 = 34$   
 $34 \times 2 = 68$   
 $238 - 68 = 170$   
 $170 \div 10 \Rightarrow \underline{17\text{ durians each}}$

Q46 (a)  $228 \div 6 = 38$   
 $38 \times 5 \Rightarrow \underline{190\text{ red marbles}}$

(b)  $190 \div 2 = 95$   
 $95 - 38 \Rightarrow \underline{57\text{ more green marbles}}$

Q47  $187 \times 3 = 561$   
 $710 - 561 = 149$   
 $187 - 149 \Rightarrow \underline{\$38\text{ per tie}}$

Q48  $256 \div 4 = 64\text{ cm}^2$   
 $\sqrt{64} \rightarrow 8$   
 $8 \times 10 \Rightarrow \underline{80\text{ cm}}$

End