



CATHOLIC HIGH SCHOOL
END-OF-YEAR EXAMINATION (2020)
PRIMARY FOUR
SCIENCE
BOOKLET A

Name: _____ ()

Class: Primary 4 - _____

Date: 3 November 2020

28 questions

56 marks

Total Time for Booklets A and B: 1 hour 30 minutes

INSTRUCTIONS TO CANDIDATES

Do not turn over this page until you are told to do so.

Follow all instructions carefully.

Answer all questions.

Shade your answers in the Optical Answer Sheet (OAS) provided.

This booklet consists of 19 printed pages, excluding the cover page.

Booklet A (28 × 2 marks)

For each question from 1 to 28, four options are given. One of them is the correct answer. Make your choice (1, 2, 3 or 4). Shade your answer on the Optical Answer Sheet. (56 marks)

- 1 Aaron found a plant in the garden and measured its height. After two weeks, he measured its height again.

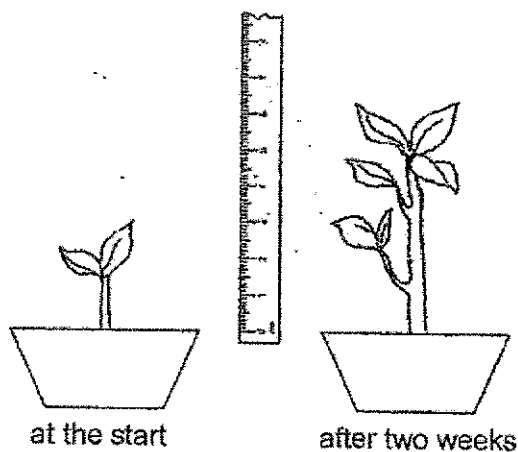

From his observation, Aaron concluded that the plant is a living thing because it can _____.

- (1) grow
- (2) breathe
- (3) respond
- (4) reproduce

2 Study the diagram below.

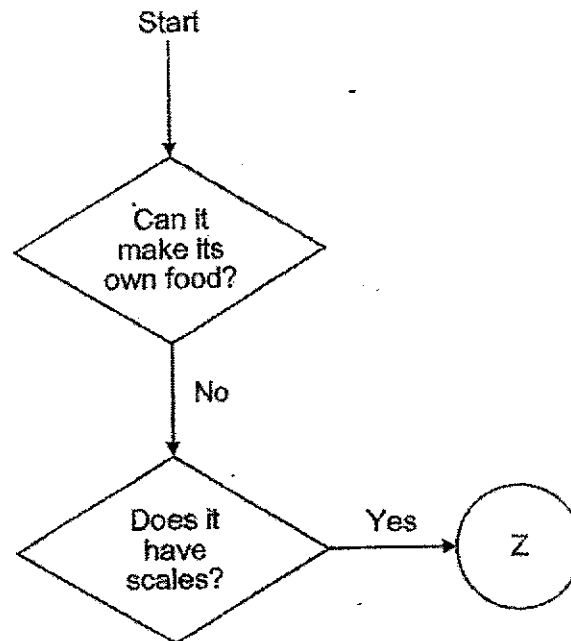

What could Z be?

- (1) plant
- (2) insect
- (3) reptile
- (4) mammal

3 The diagram below shows a kitchen knife.

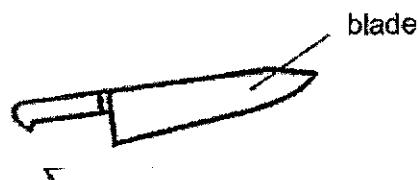

Metal is used to make the blade of the kitchen knife because metal

_____.

- (1) can sink in water
- (2) cannot absorb water
- (3) does not break easily
- (4) does not allow light to pass through

- 4 Which part, (1), (2), (3) or (4), supports the plant?

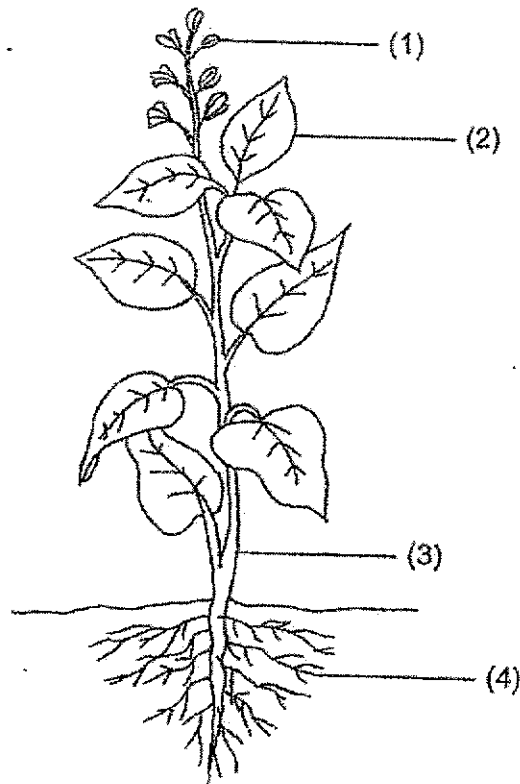

- 5 The arrows (→) in the diagram below show the direction of movement of a substance in plants.

roots → stem → leaves

What is this substance?

- (1) air
- (2) food
- (3) water
- (4) sunlight

6 Which two magnets will push each other away?

(1)

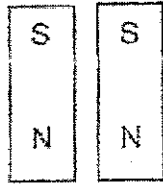

(2)

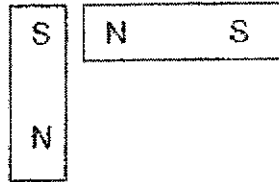

(3)

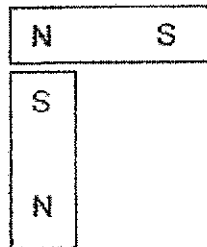

(4)



7 A, B, C and D are the various stages in the life cycle of a mosquito.



Which one of the following correctly shows the life cycle of a mosquito?

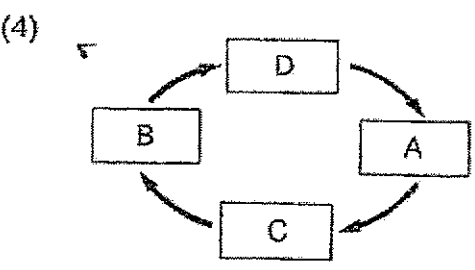
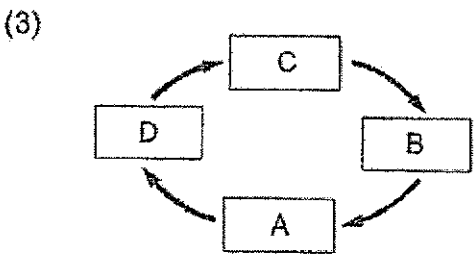
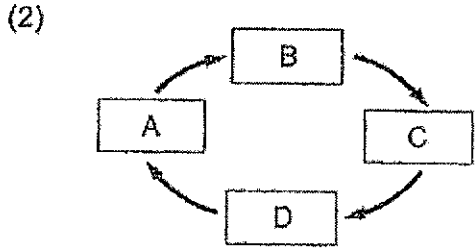
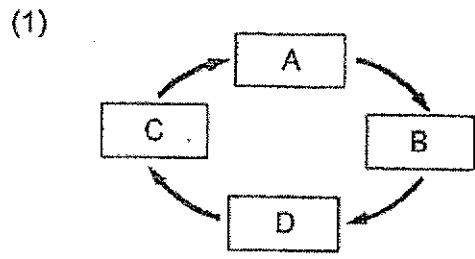

8 The diagram below shows the life cycle of a plant.

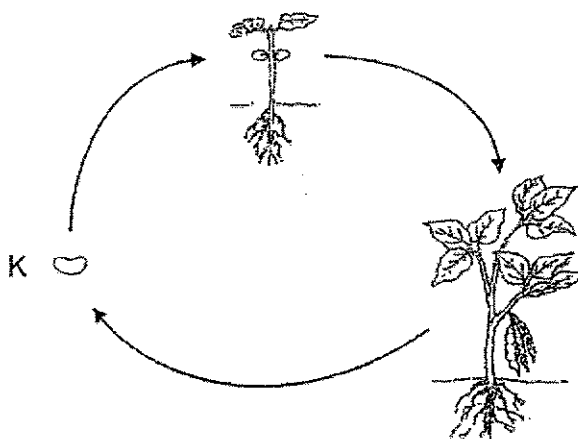

What is the stage marked K?

- (1) egg
 - (2) seed
 - (3) adult plant
 - (4) young plant
- 9 Which is **not** a source of heat?
- (1) the sun
 - (2) a lighted bulb
 - (3) a candle flame
 - (4) a thermometer

10 Look at the diagram below.

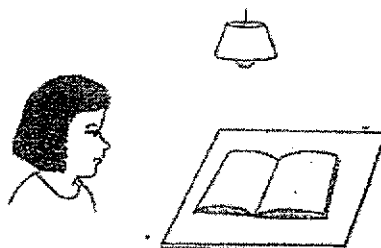

Which one of the following correctly shows why Lynn can see the book on the table?

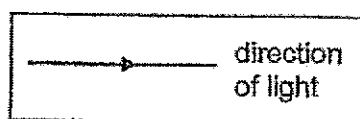

(1)

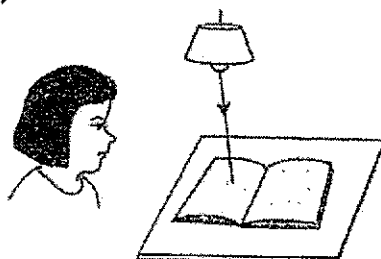

(2)

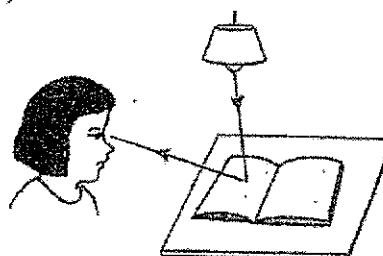

(3)

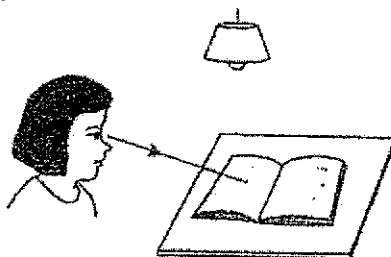

(4)

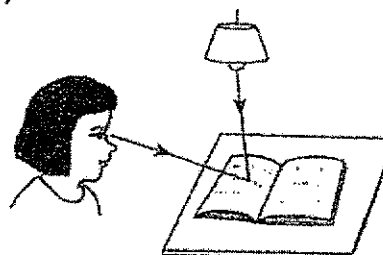

11 Which statement best describes a flowering plant?

- (1) It bears fruits.
- (2) It has big leaves.
- (3) It cannot make its own food.
- (4) It grows on other plants for support.

12 Which statements about bacteria are correct?

- A Some bacteria are useful to us.
- B Bacteria can be found everywhere.
- C Bacteria can only be seen under a microscope.

- (1) A and B only
- (2) A and C only
- (3) B and C only
- (4) A, B and C

13 Study the two living things below.

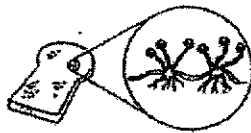

mould



mushroom

How are the mould and mushroom similar?

- (1) They can make their own food.
- (2) They can be seen only under a microscope.
- (3) They belong to the same group called fungi.
- (4) They do not need air, food and water to survive.

- 14 Balvan tied four strings, W, X, Y and Z, made of different materials around a rod. Similar metal cubes were hung onto each string, one at a time, until the string snapped.

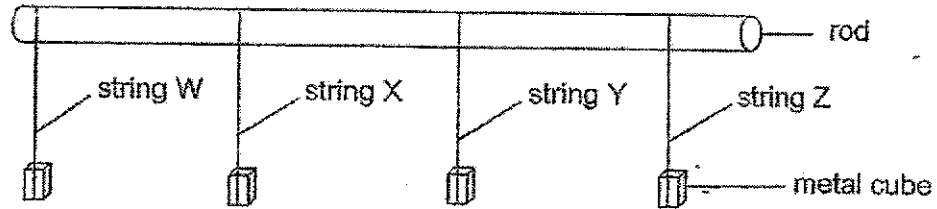

The table below shows the results of his investigation.

String	Number of metal cubes added until the string snapped
W	8
X	5
Y	3
Z	10



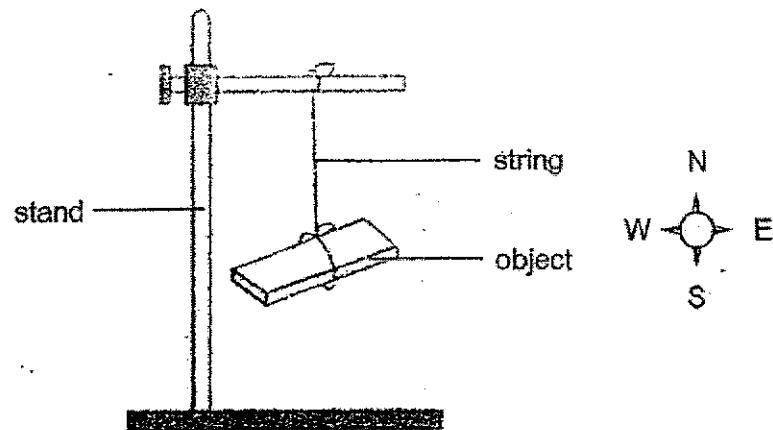

Arrange the materials from the weakest to the strongest.

	weakest	→		strongest
(1)	Y	W	X	Z
(2)	Y	X	W	Z
(3)	Z	W	X	Y
(4)	Z	X	W	Y

15 Kairavi hung four objects, A, B, C and D, on a stand as shown below.



Each object came to rest at different positions. She recorded her findings in the table below.

Object	Resting position
A	
B	
C	
D	

Based on her findings above, which object is likely to be a magnet?

- (1) A
- (2) B
- (3) C
- (4) D

- 16 In the set-up below, J, K, L and M, are four rings which pass through a smooth plastic rod. K is a magnet.

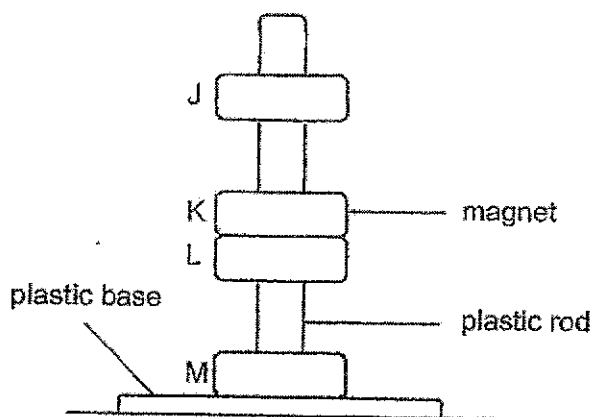

Which of the following is possible?

	J	L	M
(1)	magnet	copper	steel
(2)	magnet	magnet	magnet
(3)	steel	magnet	copper
(4)	copper	steel	magnet

- 17 The diagram below shows an electromagnet.

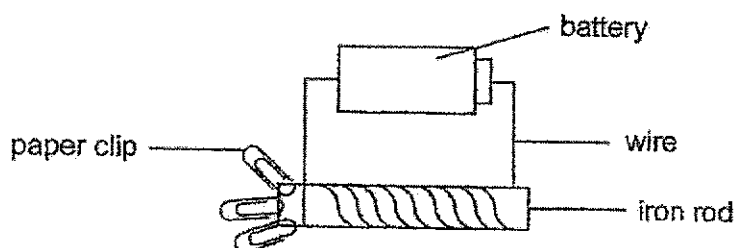

What could be done to the electromagnet in order for it to attract more paper clips?

- A increase the number of batteries
 B replace the iron rod with a copper rod
 C increase the number of coils of wire around the iron rod
- (1) A and B only
 (2) A and C only
 (3) B and C only
 (4) A, B and C

- 18 The diagram below shows the different stages of the growth of a plant.

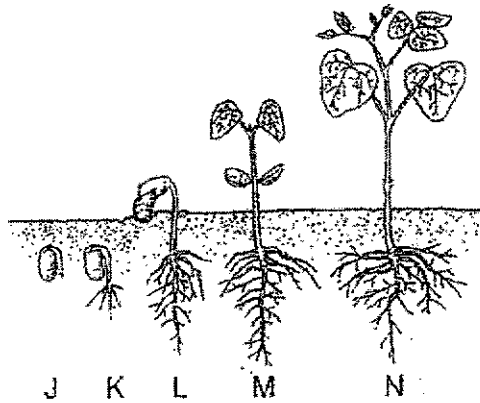

At which stage(s) can it make its own food?

- (1) J only
 - (2) J and K only
 - (3) M and N only
 - (4) L, M and N only
- 19 Each letter in the diagram below represents a stage in the life cycle of a butterfly.

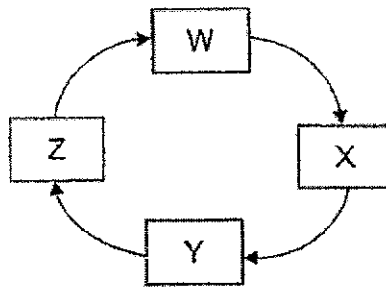

Which statement is correct if X represents the adult stage?

- (1) At stage X, it stops feeding but continues to develop.
- (2) At stage Z, it eats a lot and moults several times as it grows.
- (3) At stage W, it eats a lot and moults several times as it grows.
- (4) At stage Y, it stops feeding but does not continue to develop.

- 20 The table below shows the number of days animals R and S spend at each stage of its life cycle before developing into an adult.



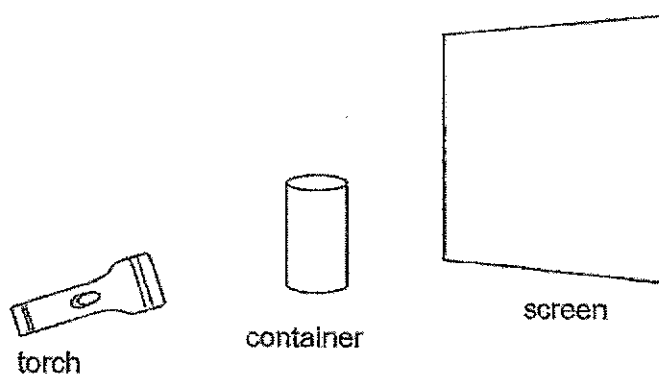

Stage of life cycle	Number of days spent at each stage of its life cycle	
	animal R	animal S
egg	4	6
larva	7	4
pupa	6	8

Based on the information above, which statement about animals R and S is correct?

- (1) Animal S has a shorter life span than animal R.
 - (2) Animal S spends less days as a pupa than animal R.
 - (3) Animals R and S have three stages in their life cycles.
 - (4) Animal R spends more days as a larva than animal S.
- 21 Gareth placed a metal container between a torch and a screen as shown below.



Which one of the following shows the shadow formed on the screen?

- (1) 
- (2) 
- (3) 
- (4) 

- 22 Faiza placed object P in container A. Next, he inserted a tube made of black cardboard into container A and looked through the tube to see if he could see object P.

He did the same for three other containers, B, C and D, using a different tube each time as shown in the diagram below.

All the containers and tubes were made of a material that does not allow any light to pass through.

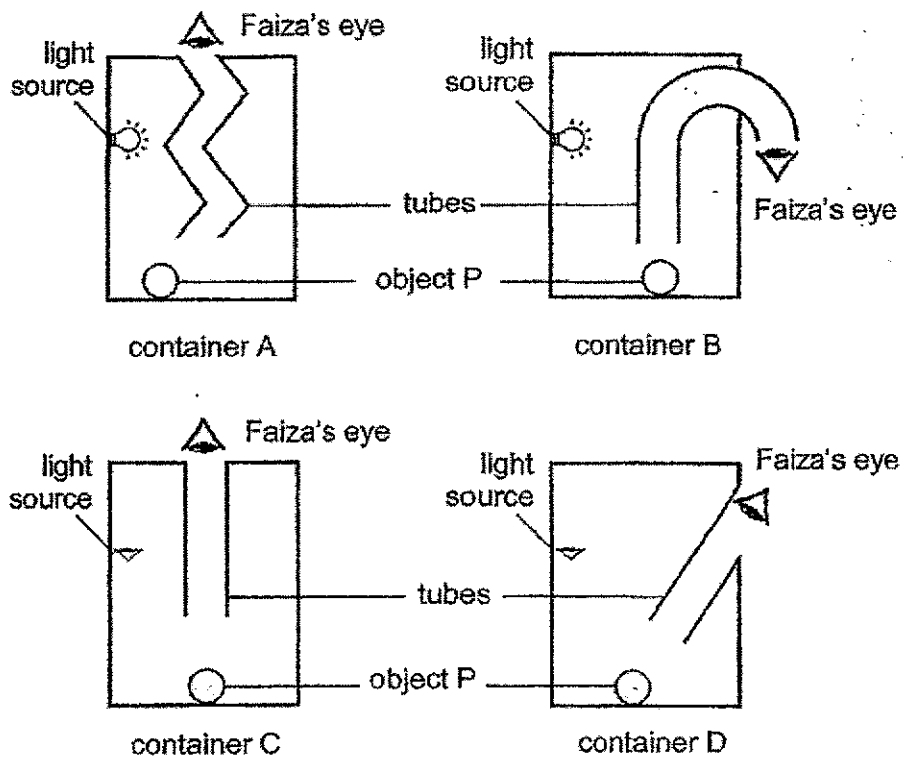

In which containers could Faiza see object P?

- (1) A and B only
- (2) A and D only
- (3) B and C only
- (4) C and D only

- 23 Haris used some wires to form three shapes for an experiment on shadows as shown below.

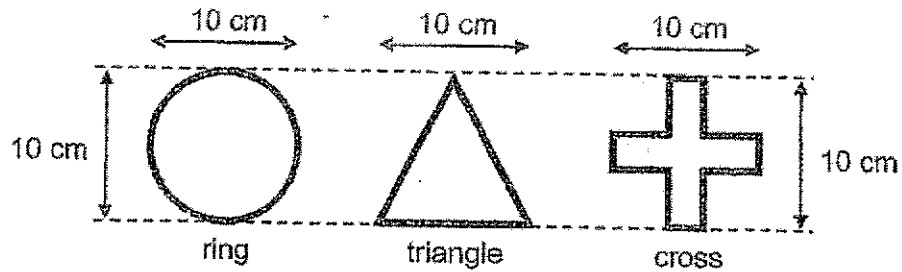

He conducted the experiment in a completely dark room using the following set-up. He hung the three shapes on a bar. The shapes were placed at different distances from the torch.

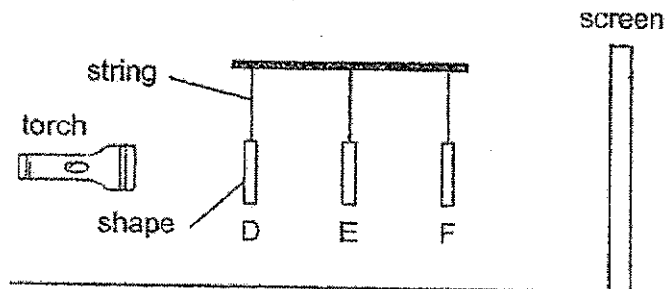

The shadow formed on the screen is as shown below.

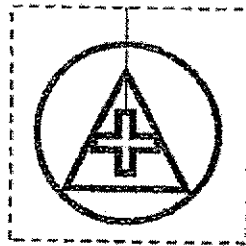

Which of the following represents correctly shapes D, E and F respectively?

	D	E	F
(1)	ring	triangle	cross
(2)	triangle	cross	ring
(3)	cross	ring	triangle
(4)	cross	triangle	ring

- 24 In a dark enclosed room, four sheets, Q, R, S and T, were arranged in a straight line as shown below. When the candle was lit, a bright circular patch of light was observed only on sheet S.

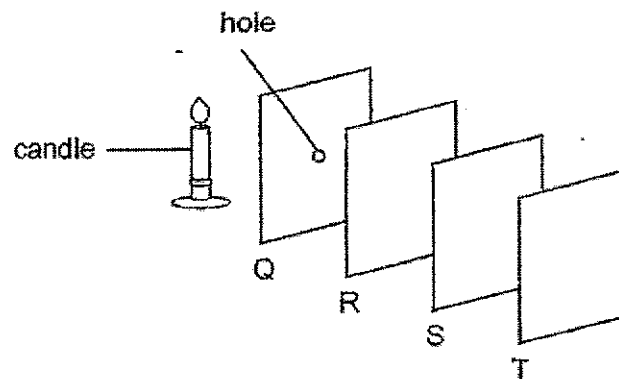

Based on the information above, which statements are correct?

- A Sheets R and T allowed light to pass through it.
- B Sheet Q allowed more light to pass through than T.
- C Sheets Q and S did not allow any light to pass through it.
- D Sheet R allowed more light to pass through than sheet S.

- (1) A and B only
- (2) A and D only
- (3) B and C only
- (4) C and D only

- 25 Ian prepared two beakers, J and K, with the same volume of water as shown below.

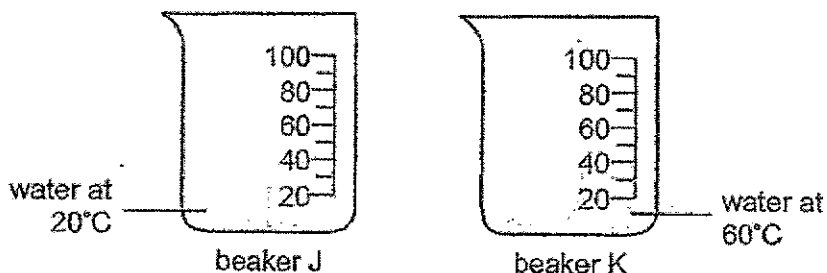

He poured the water from beaker J into beaker K without spilling it. What was the possible temperature of the water in beaker K?

- (1) 20°C
 - (2) 40°C
 - (3) 60°C
 - (4) 80°C
- 26 Janai tied a weight to a string and hung it from a piece of metal wire as shown below.

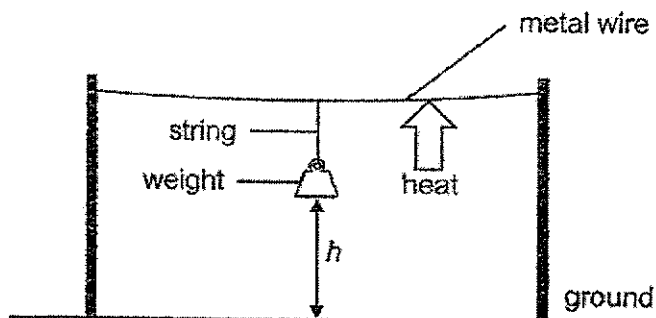

When the metal wire was heated, what would most likely happen to the height h , distance between the weight and the ground?

- (1) It remained the same.
- (2) It increased as the string contracted.
- (3) It decreased as the string expanded.
- (4) It decreased as the metal wire expanded.

27 Karen conducted an experiment using the set-up shown below.

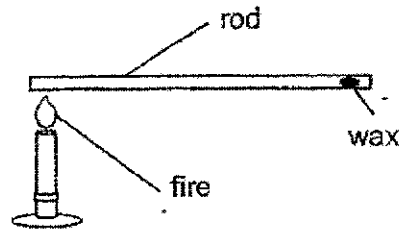

She placed a drop of wax on one end of the rod and heated the other end of the rod over a fire until the wax melted completely. She repeated the experiment using another rod of the same size but made of a different material. Her results are shown below.

Material	Time taken for the wax to melt completely (s)
K	26
L	280

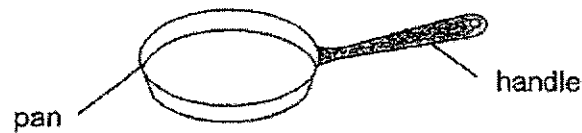

Based on the results above, which materials is most suitable to make the handle and pan?

	handle	pan
(1)	L	K
(2)	L	L
(3)	K	K
(4)	K	L

- 28 Lincoln conducted an experiment using a beaker of water to observe the changes in temperature. He measured the temperature of the water at various times as shown below.

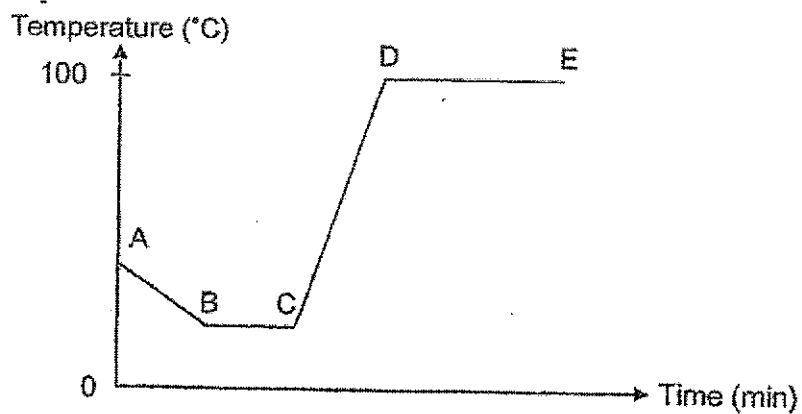

Which of the following describes the change taking place in the beaker during the experiment?

(1)	A to B	Some water was removed from the beaker.
(2)	B to C	Some ice cubes were added into the beaker.
(3)	C to D	The beaker of water was placed over the fire.
(4)	D to E	Tap water was added into the beaker.

End of Booklet A



CATHOLIC HIGH SCHOOL
END-OF-YEAR EXAMINATION (2020)
PRIMARY FOUR
SCIENCE
BOOKLET B

Name: _____ ()

Class: Primary 4 - _____

Date: 3 November 2020

Parent's Signature: _____

Booklet A	56
Booklet B	44
Total	100

13 questions

44 marks

Total Time for Booklets A and B: 1 hour 30 minutes

INSTRUCTIONS TO CANDIDATES

Do not turn over this page until you are told to do so.

Follow all instructions carefully.

Answer all questions.

Write your answers in this booklet.

This booklet consists of 15 printed pages, excluding the cover page.

Booklet B (44 marks)

For questions 29 to 41, write your answers in this booklet.

The number of marks available is shown in brackets [] at the end of each question or part question. (44 marks)

29 Zahira saw some living and non-living things on the beach.

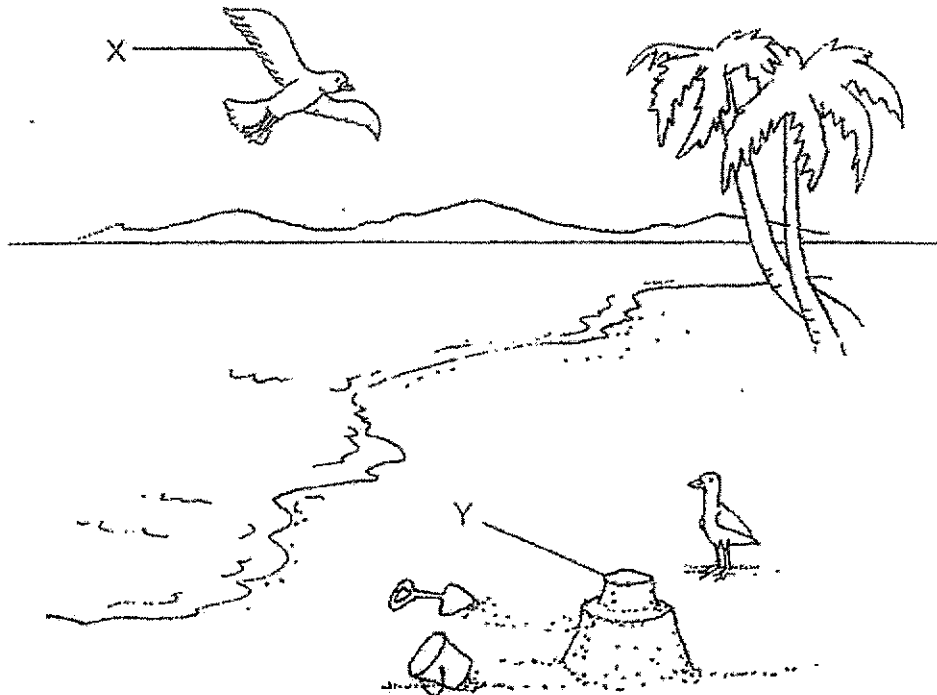

State if X and Y are living or non-living things.

(a) X is a _____ [1]

(b) Y is a _____ [1]

(Go on to the next page)

SCORE	2
-------	---

30 Draw lines to match the two organ systems to their functions.

[2]

organ systems	functions
<ul style="list-style-type: none"> • respiratory system • circulatory system 	<ul style="list-style-type: none"> • breaks down food into simpler substances • takes air into and out of the body • transports digested food, water and oxygen to all parts of the body

31 Classify the following animals according to the number of stages in their life cycle.

[2]

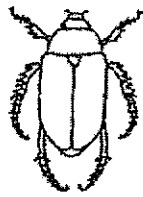

beetle

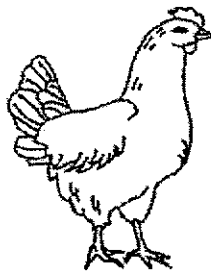

chicken



cockroach



frog

Three stages	Four stages

(Go on to the next page)

SCORE	4
-------	---

32 Two magnets are placed together as shown below.

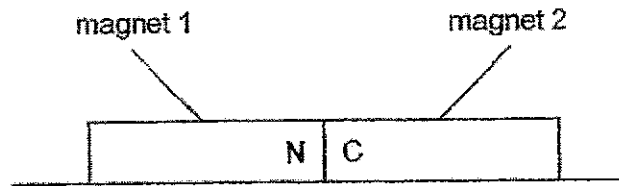

The north pole of magnet 1 is labelled N.

(a) Name the pole labelled C on magnet 2. [1]

C: _____

Rosa stroked two similar iron rods, X and Y, with the same magnet as shown below.

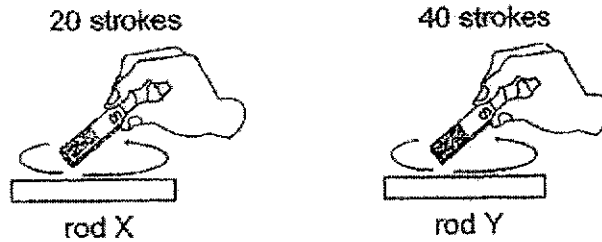

Both rods became magnets and were used to attract similar pins.

(b) Circle the correct answer below. [1]

Rod X attracted (less pins than / the same number of pins as / more pins than) rod Y.

(Go on to the next page)

SCORE	2
-------	---

33 Study the pictures below.

(a) Tick (✓) the sources of light.

[2]

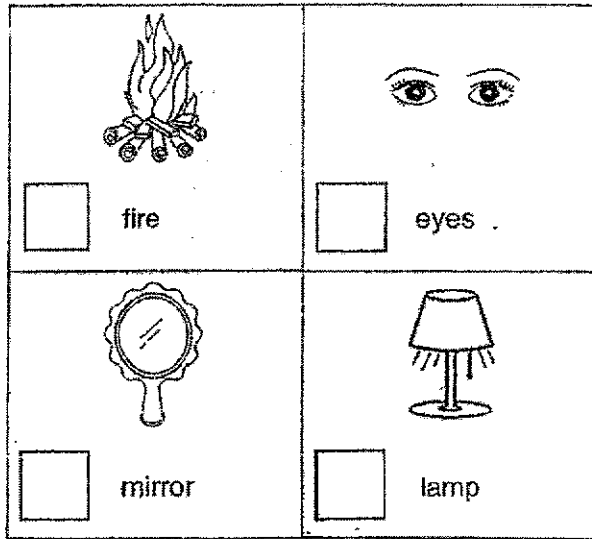

Mr Li was driving his car along a road at night with no street lamps. He could still make his way down the road using the reflective strips as shown in the diagram below. The reflective strips helped Mr Li to see in the dark from a distance.

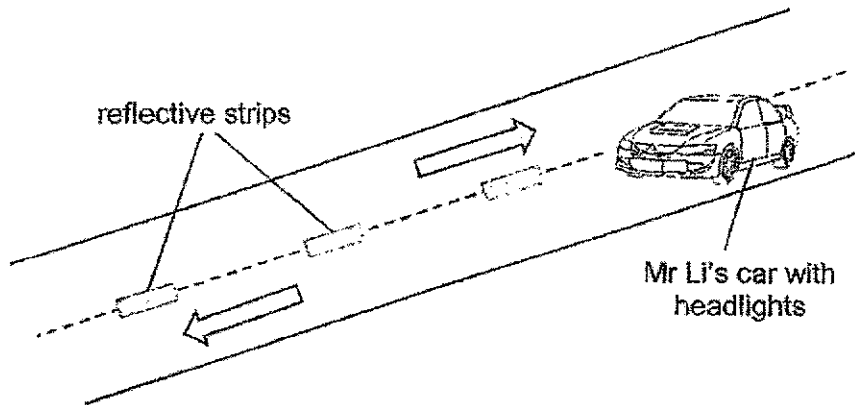

(b) Explain how Mr Li was able to see the reflective strips when he turned on his car's headlights.

[2]

(Go on to the next page)

SCORE	4
-------	---

- 34 Nathan conducted an experiment to compare the amount of water absorbed by different materials. He placed three different materials, X, Y and Z, of the same size and mass into three similar containers with the same amount of water.

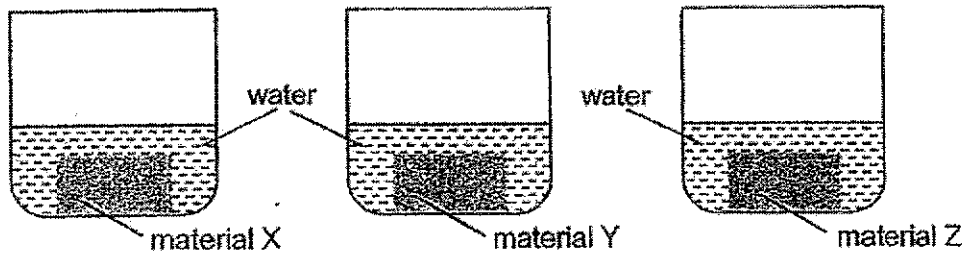

After a day, he took out the material from the container, wiped it dry and weighed each of them. The results are as shown below.

Material	Mass (g)	
	At the start	After one day
X	20	39
Y	20	20
Z	20	45

- (a) Complete the table below with X, Y and Z.

[1]

	none ← amount of water absorbed → most		
Material			

(Go on to the next page)

SCORE	1
-------	---

Continue from Question 34

The diagram below shows a surgical mask. It has a waterproof layer that can protect people against germs passed through droplets of saliva.

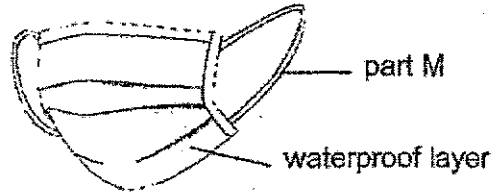

- (b) Which material is most suitable to make the waterproof layer of the surgical mask? Give a reason. [2]

- (c) Put tick(s) (✓) next to the property of the material that will make part M comfortable for the wearer. [1]

Property of the material	Tick (✓)
flexibility	
allows most light to pass through	
ability to float	

(Go on to the next page)

SCORE	3
-------	---

35 Khalid made a toy using a bar magnet tied to a stick. He moved the bar magnet over several objects as shown below.

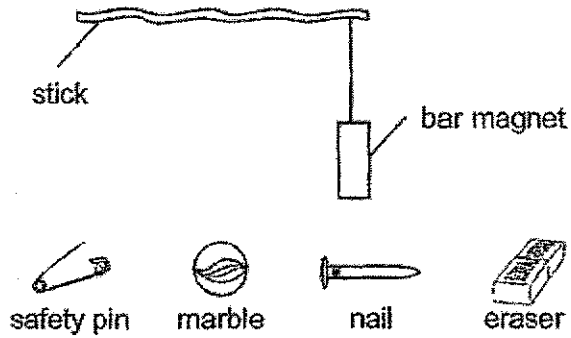

Khalid made some observations about the materials and recorded them in the diagram below.

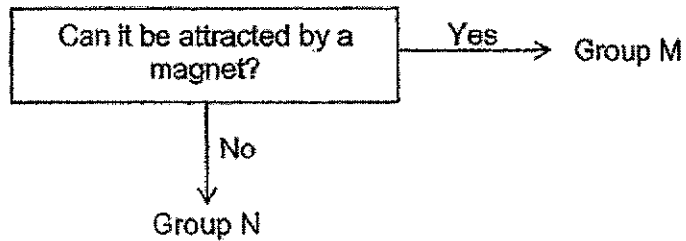

(a) Based on the observations above, give a suitable heading for groups M and N in (i) and classify all the given objects into the diagram in (ii) below. [2]

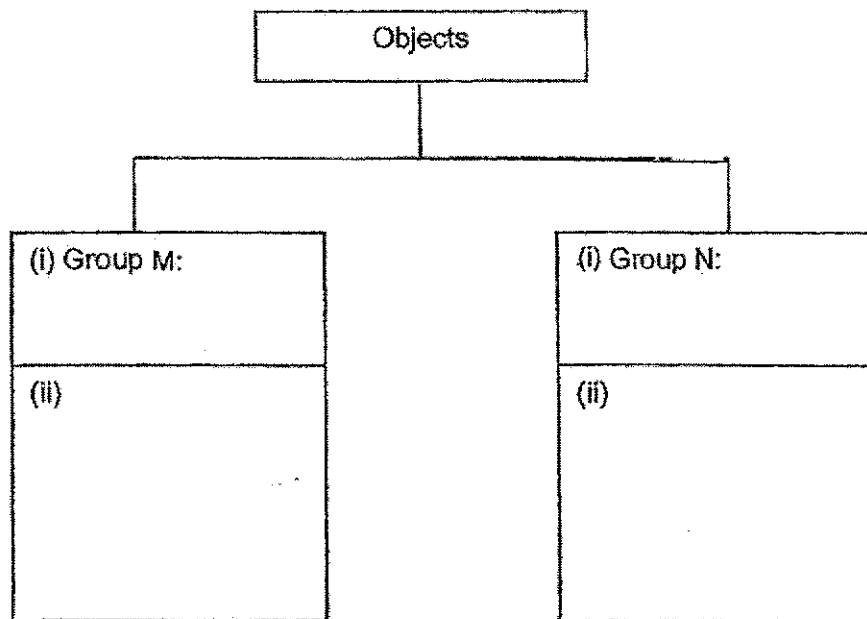

(Go on to the next page)

SCORE	2
-------	---

Continue from Question 35

Khalid had some knives being held by a bar that was fixed to the wall in the kitchen as shown below.

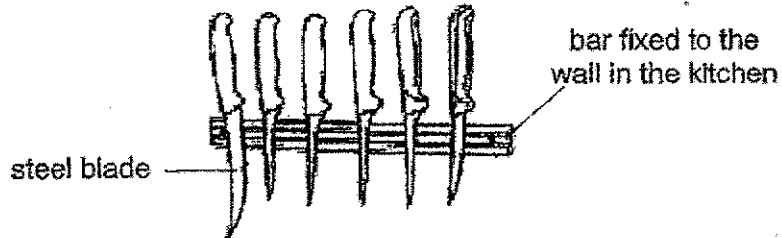

(b) Explain why the knives would not fall off the wall.

[2]

(Go on to the next page)

SCORE	2
-------	---

- 36 Jie Ying conducted an experiment to find out how the presence of water affects the growth of the mould as shown.

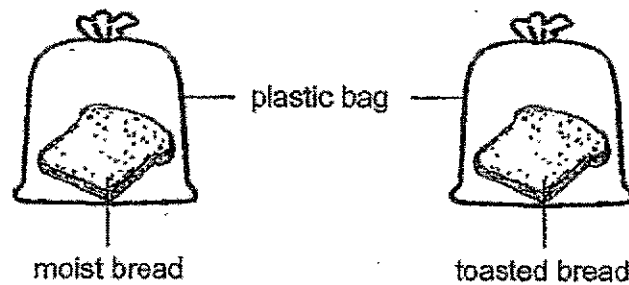

- (a) Put a tick (✓) next to each variable to show if it should be changed, kept the same or measured. [2]

Variable	Variable changed	Variable kept the same	Variable measured
size of bread			
amount of water			
amount of mould			
size of plastic bag			

- (b) Which bread would have mould growing on it first? Give a reason. [1]

- (c) Besides air and water, state one other condition bread mould needs in order to grow. [1]

(Go on to the next page)

SCORE	4
-------	---

37 The diagram below shows the amount of digested and undigested food found in different parts of the digestive system as food passes through them.

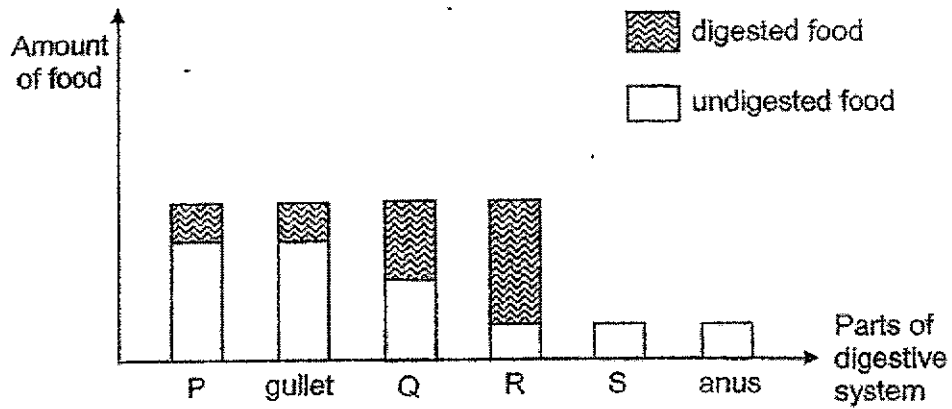

(a) Name the parts represented by P, Q, R and S. [2]

Parts of digestive system	Name the parts
P	
Q	
R	
S	

(b) In which part, P, Q, R or S, of the digestive system is food being cut into smaller pieces? [1]

(c) What happens to the digested food in part R? [1]

(Go on to the next page)

SCORE	4
-------	---

38 The diagram below shows a beetle laying eggs.

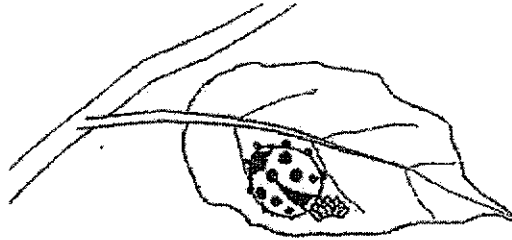

(a) Why does the beetle lay its eggs on the leaf? [1]

(b) How does laying many eggs each time helps the beetles in their survival? [1]

(c) Why is it more difficult to catch the adult beetle as compared to the larva? [1]

(d) Why is it important for living things to reproduce? [1]

(Go on to the next page)

SCORE	4
-------	---

- 39 In the set-up below, an object is placed at the centre with six light bulbs, A, B, C, D, E and F around it.

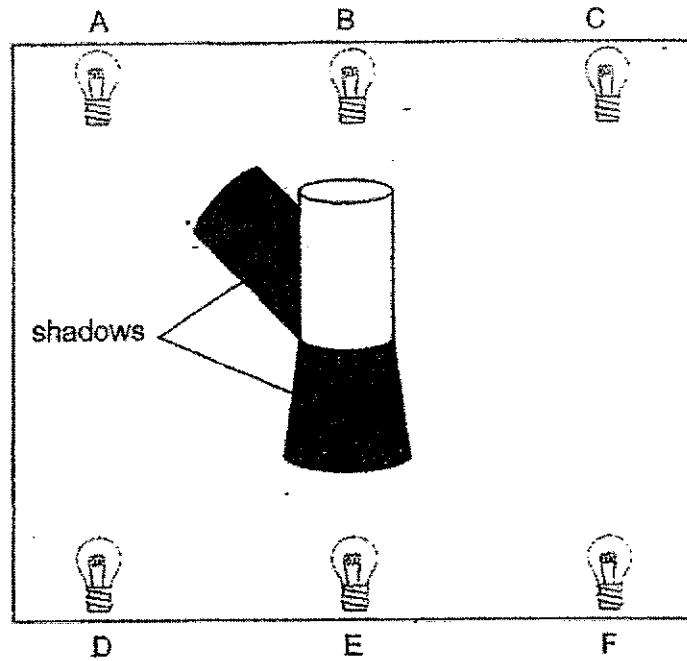

- (a) Which light bulbs are switched on to form the shadows shown above? [1]

- (b) What property of the object enables it to form a shadow? [1]

- (c) How is a shadow formed? [1]

- (d) State the property of light that allows shadows to be formed. [1]

(Go on to the next page)

SCORE	4
-------	---

- 40 Jasim conducted an experiment using three identical glasses wrapped in different materials, X, Y and Z, as shown below. He poured the same amount of water at 80°C into each glass and measured the temperature of the water after ten minutes.

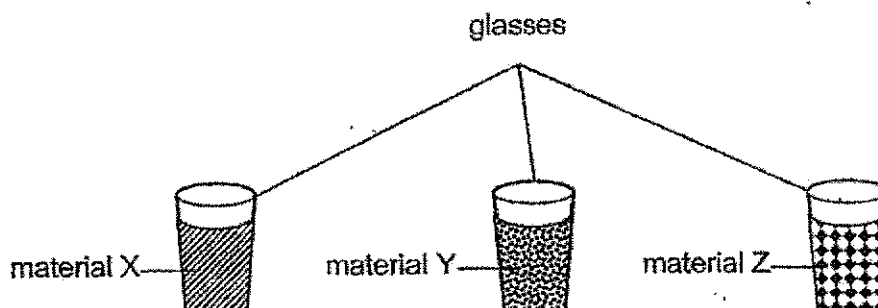

His results are shown below.

Material	Temperature of water after 10 minutes ($^{\circ}\text{C}$)
X	55
Y	35
Z	70

- (a) Based on the results above, which material, X, Y or Z, would Jasim choose to wrap an ice stick to prevent it from melting quickly? Explain why.

[2]

(Go on to the next page)

SCORE	2
-------	---

Continue from Question 40

Jasim found out that holding a cup of hot tea with a rippled surface would feel less hot compared to holding a cup of tea with a smooth surface.

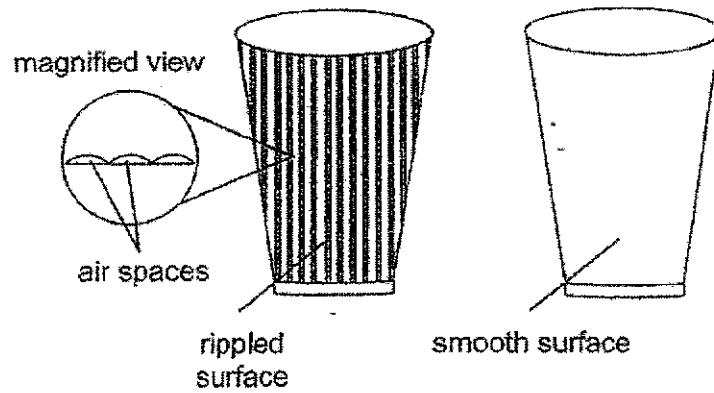

(b) Explain why it felt less hot to hold a cup of hot tea with a rippled surface. [2]

(Go on to the next page)

SCORE	2
-------	---

- 41 Boon Hwee conducted an experiment in the Science room at 30°C using the set-ups as shown below. He heated two containers of water at the same time.

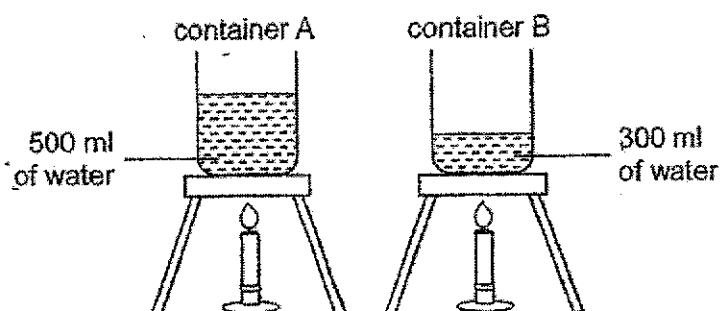

- (a) After ten minutes, Boon Hwee noticed that the water in container B started to boil but not the water in container A. Explain why. [2]

- (b) After the water in both containers boiled for two minutes, Boon Hwee removed them from the heat source and cracked an egg into each container at the same time. In which container would the egg be cooked first? Give a reason. [1]

- (c) The two containers were left on the table in the Science room. What would be the final temperature of the water after 5 hours in both containers? [1]

End of Booklet B

SCORE	4
-------	---

ANSWER KEY

YEAR : 2020
 LEVEL : PRIMARY 4
 SCHOOL : CATHOLIC HIGH
 SUBJECT : SCIENCE
 TERM : SA2

BOOKLET A

Q1	1	Q2	3	Q3	3	Q4	3	Q5	3
Q6	1	Q7	4	Q8	2	Q9	4	Q10	2
Q11	1	Q12	4	Q13	3	Q14	2	Q15	1
Q16	2	Q17	2	Q18	3	Q19	2	Q20	4
Q21	1	Q22	4	Q23	1	Q24	4	Q25	2
Q26	4	Q27	1	Q28	3				

BOOKLET B

Q29	a) X is a living thing. b) Y is a non-living thing.						
Q30	Respiratory system --- takes air into and out of the body Circulatory system --- transports digested food , water and oxygen to all parts of the body.						
Q31	Three stages Chicken , cockroach , frog	Four stages Beetle					
Q32	a) C : south pole b) Rod X attracted less pins than rod Y.						
Q33	a) Fire and Lamp b) The light from Mr Li's car head lights reflected off the reflective strip and into Mr Li's eyes.						
Q34	a) None----amount of water absorbed ---most <table border="1" style="width: 100%; text-align: center;"> <tr> <td>Material</td><td>Y</td><td>X</td><td>Z</td></tr> </table> b) Material Y as material Y did not absorb any water after a day c) Flexibility ✓			Material	Y	X	Z
Material	Y	X	Z				

Q35 a)

```

graph TD
    A[Objects] --> B["i) Group M:  
Magnetic  
Material"]
    A --> C["i) Group N:  
Non magnetic  
material"]
    B --> D["ii) Safety Pin  
Nail"]
    C --> E["ii) Marble  
Eraser"]
    
```

b) As the bar is a magnet and steel is a magnetic material so the steel blade will be attracted to the bar.

Q36

a)

Variable	Variable changed	Variable kept the same	Variable measured
Size of bread		✓	
Amount of water	✓		
Amount of mould			✓
Size of plastic bag		✓	

b). The bread with moist as mould needs moist to grow.
c). Warmth

Q37

a)

Parts of digestive system	Name the parts
P	Mouth
Q	Stomach
R	Small intestine
S	Large intestine

b). P
c). it would be absorb into the blood stream and transported to other parts of the body.

Q38	<p>a) So when the eggs hatch , they will have food to eat.</p> <p>b) The eggs hatch into young and grown into adults.</p> <p>c) As the adult has wings to fly but the larva does not have wings to fly.</p> <p>d) It is to ensure the continuous of their kind.</p>
Q39	<p>a) B , F</p> <p>b) It must be opaque.</p> <p>c) It is formed when light is blocked by an object.</p> <p>d) Light travels in a straight line.</p>
Q40	<p>a) Z, because Z was the poorest conductor of heat since temperature of water after 10 minutes is the highest so the ice stick gained heat from the surroundings the slowest.</p> <p>b) Air is a poor conductor of heat so the hand gained heat from the hot tea is slower.</p>
Q41	<p>a) B had less water so less heat was needed to boil a smaller amount of water.</p> <p>b) Container A as there is more heat in A than in B.</p> <p>c) Room temperature</p>

3
END.

