

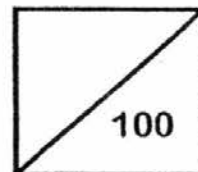

Rosyth School
Second Semestral Examination for 2016
SCIENCE
Primary 4

Name: _____

Total
Marks:



Class: Pr 4 _____ Register No. _____ Duration: 1 h 45 min

Date: 25th October 2016 Parent's Signature: _____

Booklet A

Instructions to Pupils:

1. Do not open the booklets until you are told to do so.
2. Follow all instructions carefully.
3. This paper consists of 2 booklets, Booklet A and Booklet B.
4. For questions 1 to 28 in Booklet A, shade the correct ovals on the Optical Answer Sheet (OAS) provided using a 2B pencil.

* This booklet consists of 16 pages.

Booklet A (56 marks)

For each question from 1 to 30, four options are given. One of them is the correct answer. Make your choice (1, 2, 3 or 4). **Shade the correct oval (1, 2, 3 or 4) on the Optical Answer Sheet.**

1. Which one of the following statements is true for ALL insects?

- (1) They have six legs.
- (2) They have tails.
- (3) They have wings.
- (4) They live on land.

2. The diagram below shows the life cycle of an animal.

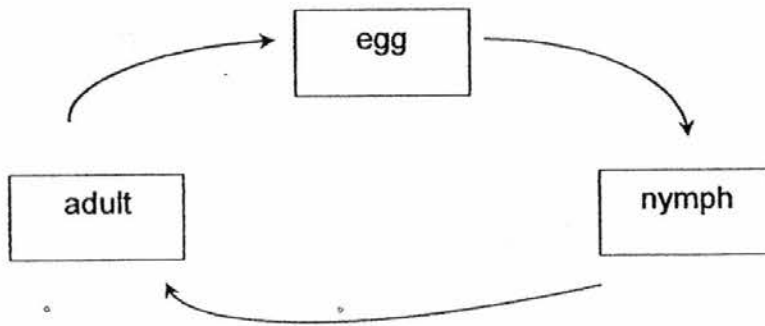

Which animal is likely to have the life cycle as shown above?

- (1) beetle
- (2) butterfly
- (3) chicken
- (4) cockroach

3. The diagram below shows a young plant.

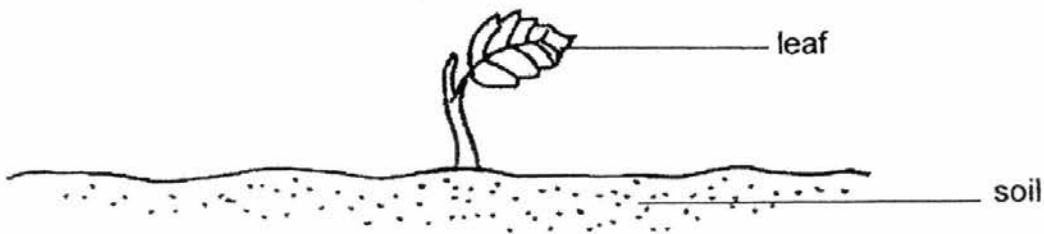

The leaf helps the plant to _____.

- (1) make food
- (2) absorb water
- (3) grow upright
- (4) absorb nutrients

4. Which one of the following shows the correct order when food moves through some parts of the digestive system?

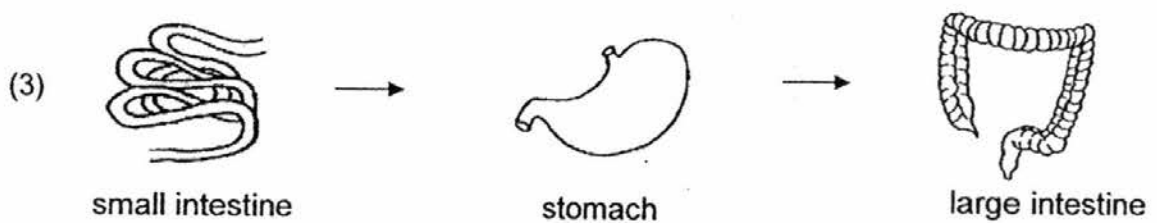

5. The diagram shows a painting hanging on a wall.

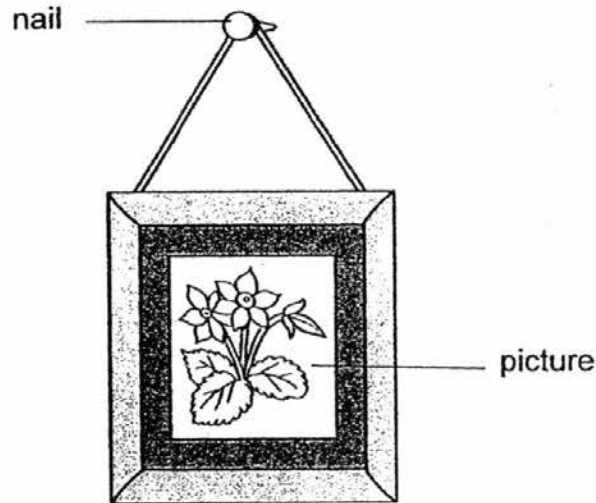

Iron is used to make nails because iron is _____

- (1) shiny
(2) strong
(3) heavy
(4) flexible
6. Which one of the following properties is true for both air and a pen?
- (1) They can be seen.
(2) They have fixed shapes.
(3) They have fixed volumes.
(4) They take up space.
7. In which one of the following will the two magnets push each other away?

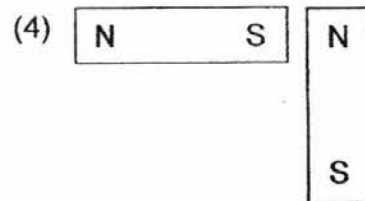
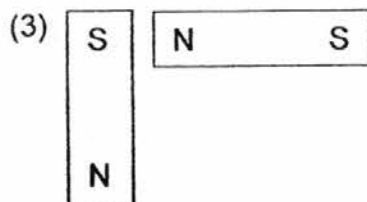
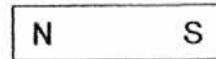
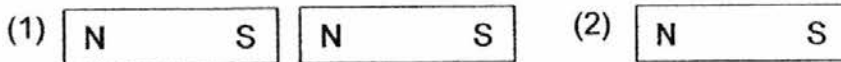

8. The set-up below shows light shining on a wooden block.

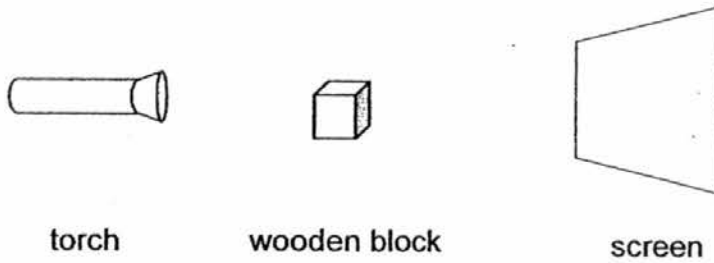

Which one of the following would likely be seen on the screen?

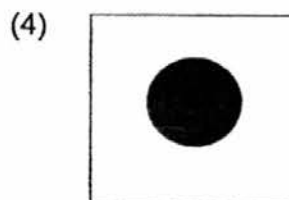
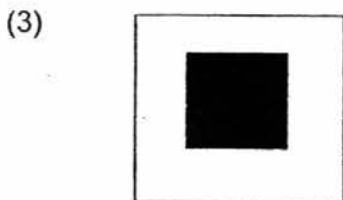
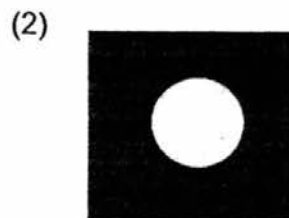

9. Ronald places a metal spoon in a cup of hot tea.

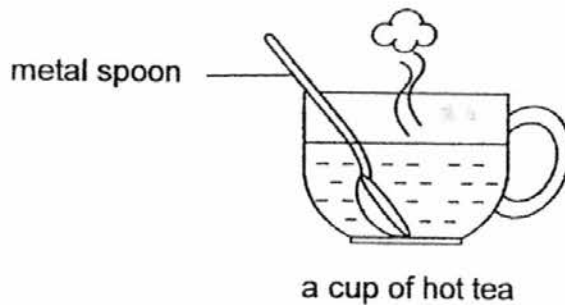

The spoon becomes hotter after a while.

Which one of the following explains this?

- (1) The cup loses heat to the hot tea.
- (2) The spoon loses heat to the hot tea.
- (3) The hot tea gains heat from the spoon.
- (4) The spoon gains heat from the hot tea.

10. Hashim heated some food in the frying pan shown below.

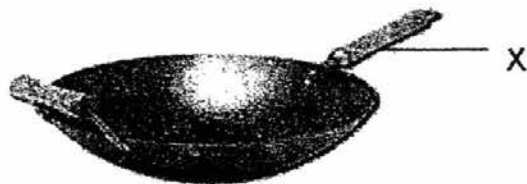

He is able to hold the frying pan using the plastic handle, X. This is because plastic is a _____.

- (1) light material
 - (2) flexible material
 - (3) poor conductor of heat
 - (4) good conductor of heat
11. Judy set up the experiment below. She put two identical pieces of bread, A and B, into a transparent bag each, and placed them in a dark cupboard.

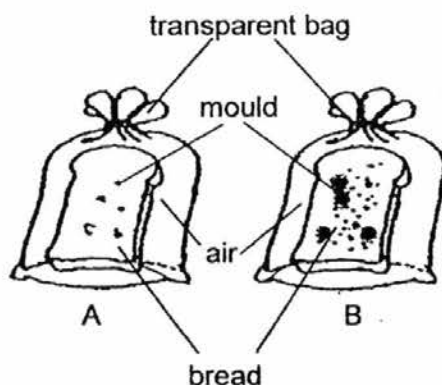

She added a few drops of water to B but not A. Few days later, she observed that B had more mould than A. Based on the experiment, which of the following is correct?

- (1) Mould grows in dark places.
- (2) Mould needs sunlight to grow.
- (3) Mould needs oxygen to survive
- (4) Mould grows faster on bread with more moisture.

12. Emily had four animals as shown below.



dog



frog



grasshopper



chicken

She classified them using the chart below.

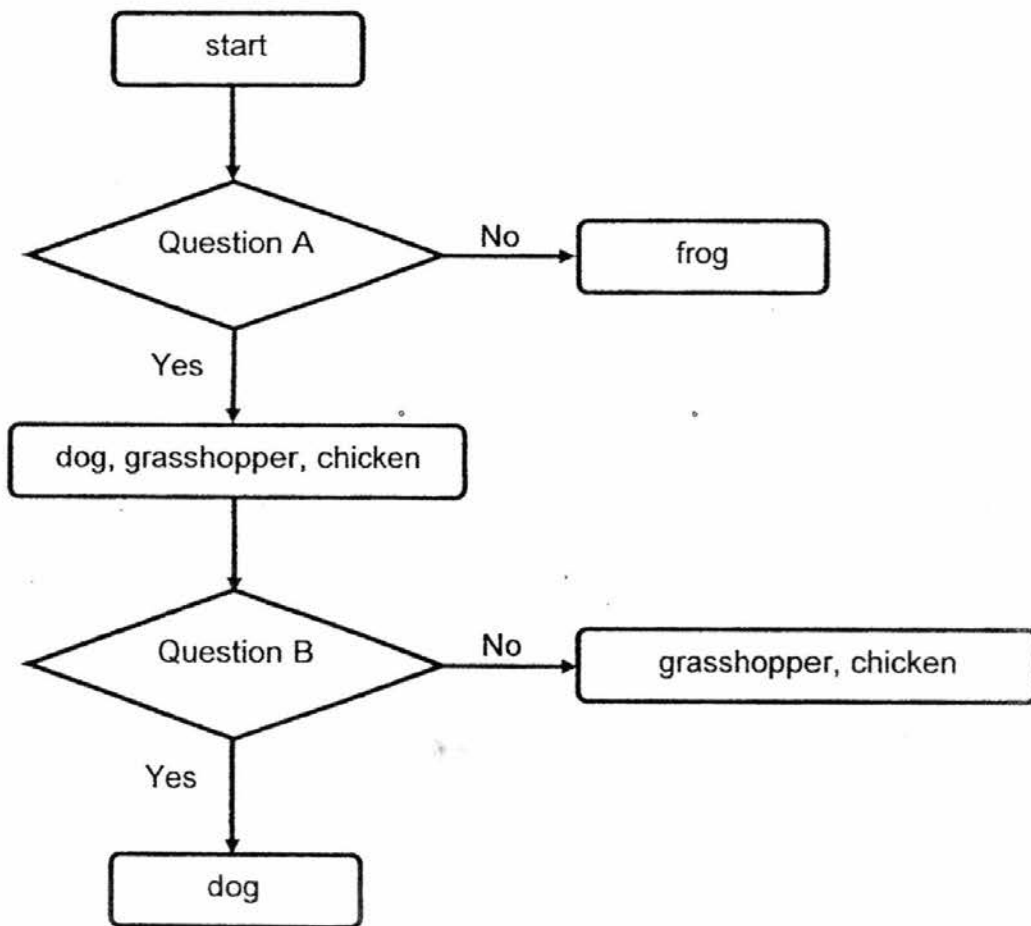

What were the two questions, A and B?

	Question A	Question B
(1)	Does it live on land only?	Does it lay eggs?
(2)	Does it lay eggs?	Does it live on land only?
(3)	Does it live on land only?	Does it give birth to young alive?
(4)	Does it lay eggs?	Does it give birth to young alive?

13. The graph shows the amount of food that is eaten at different stages of the life cycle of a mealworm beetle.

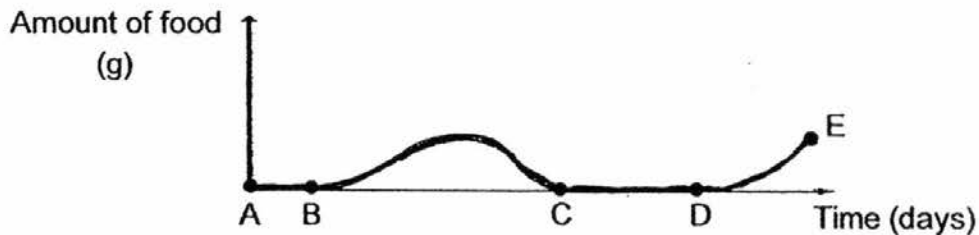

If E is the adult stage of the mealworm beetle, which of the statement(s) is/are true about the graph?

P: The length of the egg stage is from A to B.

Q: The least amount of food was eaten from B to C.

R: The mealworm beetle was going through its pupa stage from C to D.

(1) P only

(2) P and R only

(3) Q and R only

(4) P, Q and R

14. Chloe set up an experiment based on the conditions shown in the table below. She wanted to find out how the growth of rose plants was affected by different types of soil. She observed and recorded the heights of her plants for 10 days.

Conditions	Pot X	Pot Y	Pot Z
Types of soil	clayey soil	garden soil	sandy soil
Water given	once daily	once daily	twice daily
Type of plant	rose	rose	rose
Presence of light	Yes	No	Yes

Chloe's friend said that her experimental set-ups were not fair. What must she do to ensure that her set-up was a fair one?

A: Water pot Z once daily.

B: Use the same type of soil.

C: Use different types of plants.

D: Place pot Y in the presence of light.

(1) A and B only

(2) C and D only

(3) A and D only

(4) A, B and C only

15. Study the life cycle of animals P and Q below.

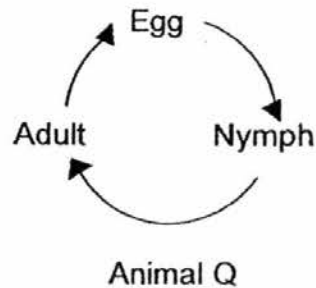
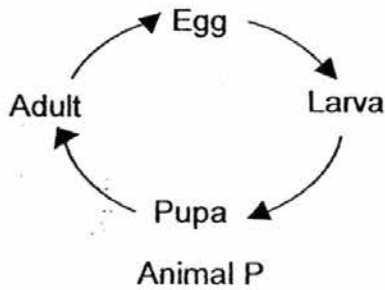

Based on the life cycles of animals P and Q, which of the following statement(s) is/are true?

- A: Animal P lays eggs in water but animal Q lays eggs on land.
- B: Animal P has four stages in its life cycle but animal Q has three stages.
- C: Animal P takes a longer time than animal Q to develop from an egg to an adult.
- D: The young of animal P does not look like the adult but the young of animal Q does.

- (1) B only
- (2) A and C only
- (3) B and D only
- (4) A, C and D only

16. The diagram below shows the roots of two plants.

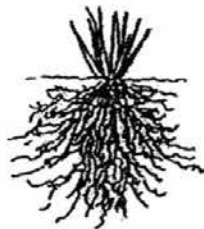

roots X



roots Y

How are the roots X different from roots Y?

- A: Roots X are able to make more food than roots Y
- B: Roots X are able to trap more sunlight than roots Y
- C: Roots X are able to absorb more water than roots Y
- D: Roots X are able to hold the plant more firmly to the ground than roots Y

- (1) A and B
- (2) A and D
- (3) B and C
- (4) C and D

17. Study the properties of four materials, M, N, O and P, given in the table below.

Material	Properties		
	Transparent	Good conductor of Heat	Magnetic
M	No	No	No
N	No	Yes	Yes
O	No	Yes	No
P	Yes	No	No

Which one of the Materials M, N, O and P is most likely to be iron?

- (1) Material M
 (2) Material N
 (3) Material O
 (4) Material P
18. Huili conducted an experiment to study the strength of four different materials, A, B, C and D. She placed 20g weights on each material and recorded the number of weights it can hold before the material broke.

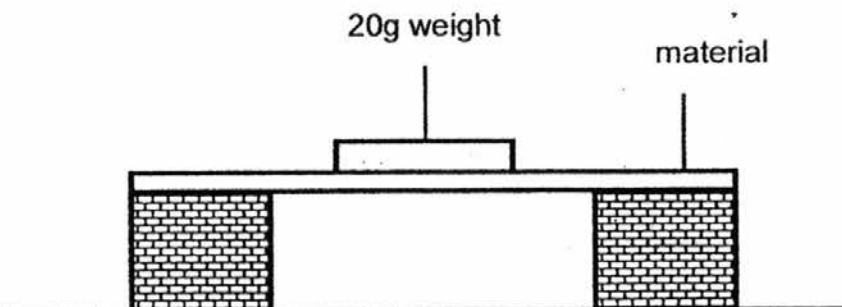

The table below shows her results.

Material	Number of 20g weights it can hold before it broke
A	8
B	13
C	2
D	10

Which one of the following shows the correct order of the materials, starting from the weakest to the strongest?

- (1) B, A, D, C
 (2) B, D, A, C
 (3) C, A, D, B
 (4) C, A, B, D

19. Ken conducted the experiment below. He filled the syringe with 500cm^3 of substance X. After that he pushed the plunger in and observed the following.

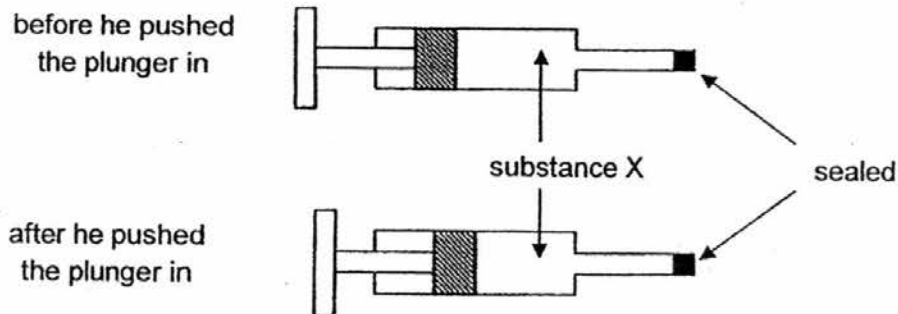

Based on the experiment, which of the following(s) is/are true about substance X?

- A: It has mass.
- B: It has no definite shape.
- C: It has no definite volume.

- (1) C only
- (2) A and B only
- (3) B and C only
- (4) A, B and C

20. A container with 3 openings labelled X, Y and Z is shown in the diagram below.

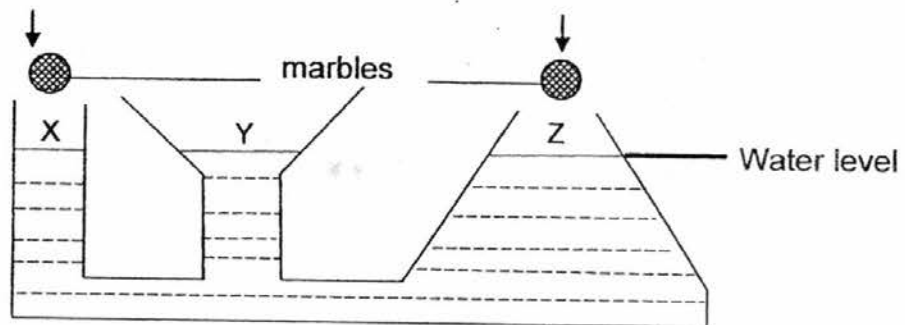

2 marbles are dropped slowly into the container from openings X and Z as shown. What will happen to the water level at Y?

- (1) Decreases
- (2) Increases
- (3) Remains the same
- (4) Decreases then Increases

21. The diagram below shows three identical 500ml beakers, A, B and C containing different items.

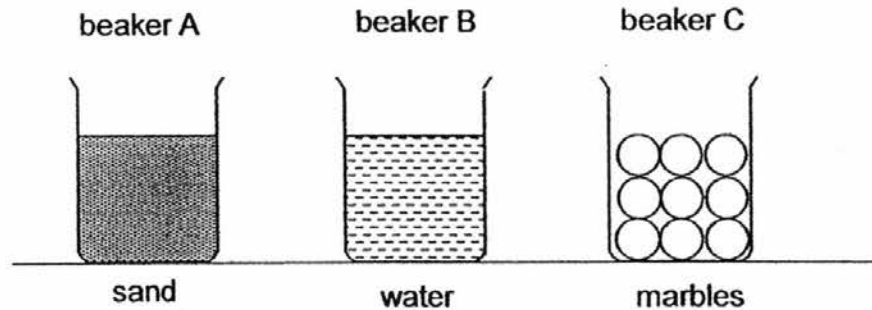

A jug of 400ml of water is poured into each beaker at the same time. Which one of the following shows the correct order in which the water in the beaker will overflow from the first to the last?

	First	→	Last
(1)	water		sand
(2)	water		marbles
(3)	marbles		water
(4)	sand		Marbles

22. Jerry was given three objects, A, B and C, which were wrapped in paper. The objects were of similar size. He held a magnet about 2cm away from each object as shown below.

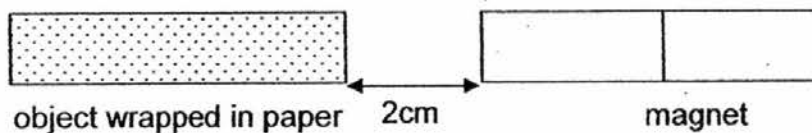

He recorded his observations in the table below.

Object	Observation
A	It remained still.
B	It moved away from the magnet.
C	It moved towards the magnet.

Which one of the objects, A, B or C, is definitely a magnet?

- (1) B only
 (2) C only
 (3) B and C only
 (4) A, B and C

23. Ricky set up an experiment as shown below.

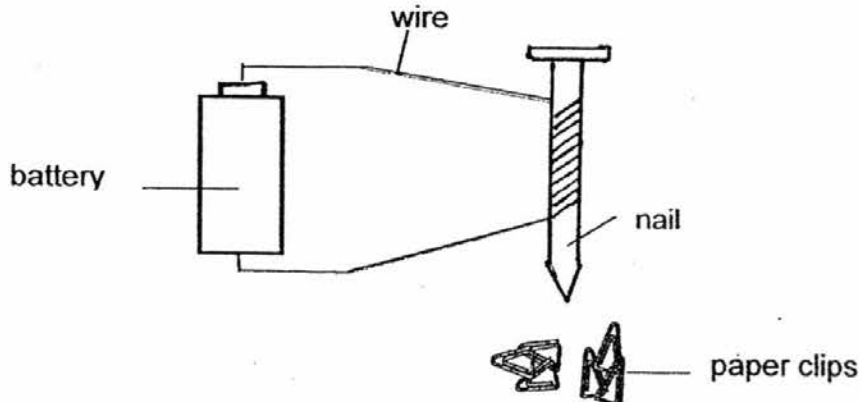

He repeated the experiment by increasing the number of coils around the nail and the result of the experiment was given in the table below.

Number of coils around the nail	Number of paper clips attracted
20	2
25	4
30	7
35	8

What is the possible relationship that can be concluded from the above experiment?

- (1) As the number of coils around the nail increases, the number of paper clips attracted decreases.
- (2) As the number of coils around the nail increases, the number of paper clips attracted also increases.
- (3) As the number of paper clips attracted increases, the number of coils around the nail also increases.
- (4) As the number of paper clips attracted increases, the number of coils around the nail decreases.

24. Vivian set up an experiment as shown below.

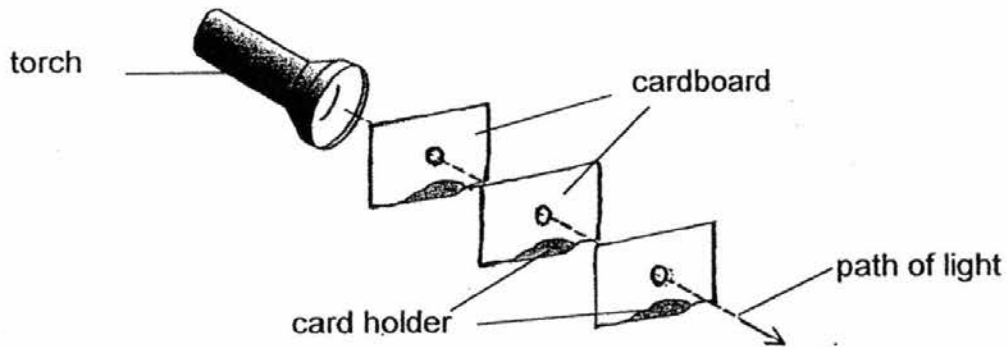

What can she conclude from the experiment?

- (1) Light can be reflected.
- (2) Light can be absorbed.
- (3) Light travels in straight lines.
- (4) Light is blocked by opaque objects.

25. Linda set up and conducted an experiment as shown below.

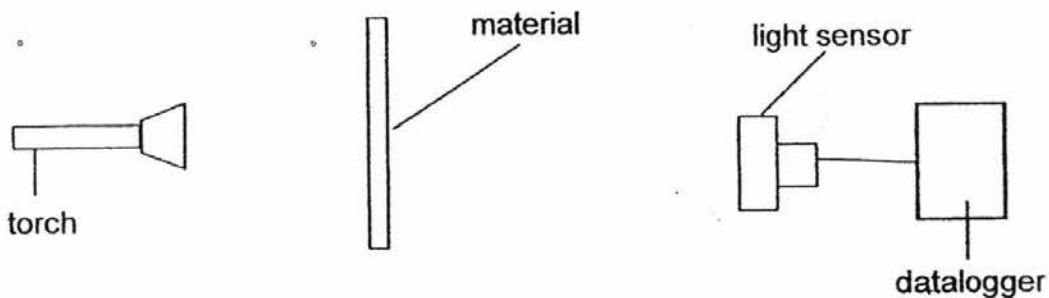

She wanted to find out the amount of light that can pass through the materials. First, she used material A. Then she replaced it with material B, followed by material C.

Which one of the following was the changed variable in her experiment?

- (1) Amount of light
- (2) Type of material
- (3) Thickness of material
- (4) Distance between material and the torch

26. One night, Tom noticed that the length of his shadow changed as he walked along the path in the direction of the arrow as shown in the diagram below.

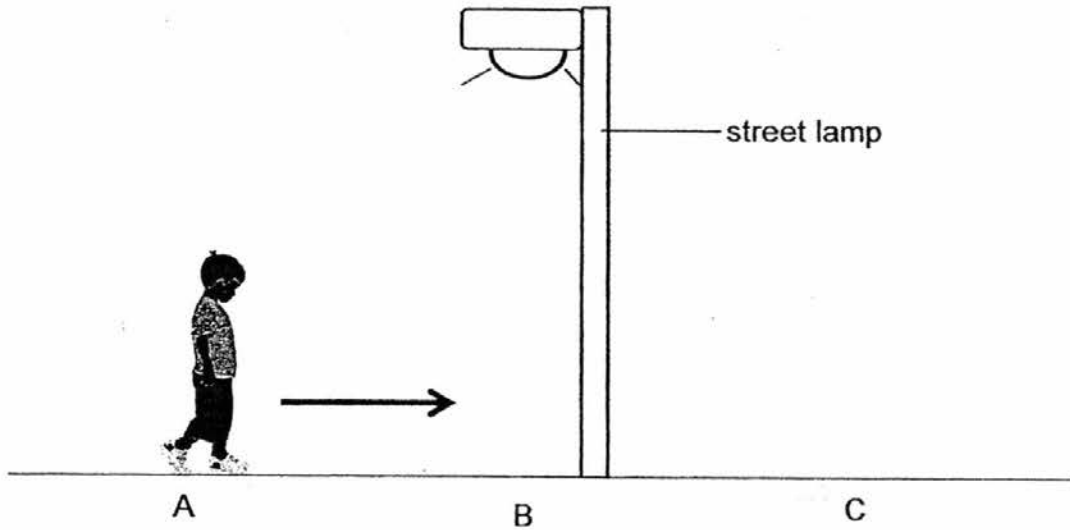

Which one of the following graphs shows the changes in the length of Tom's shadow as he moved from A to C?

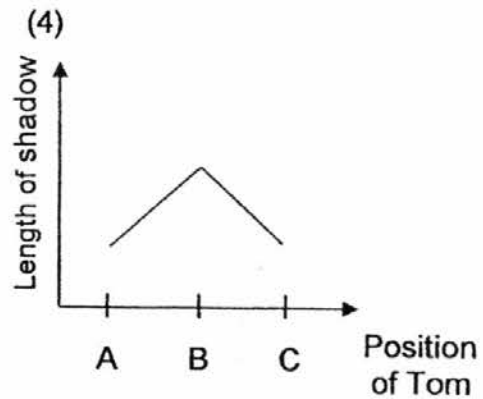
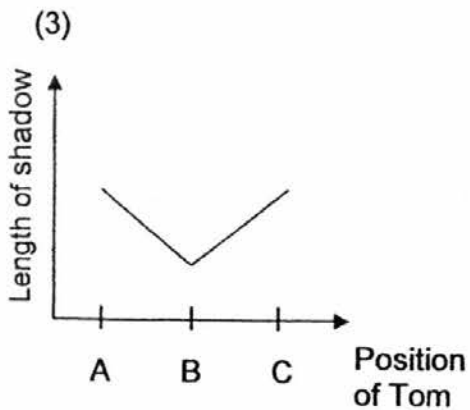
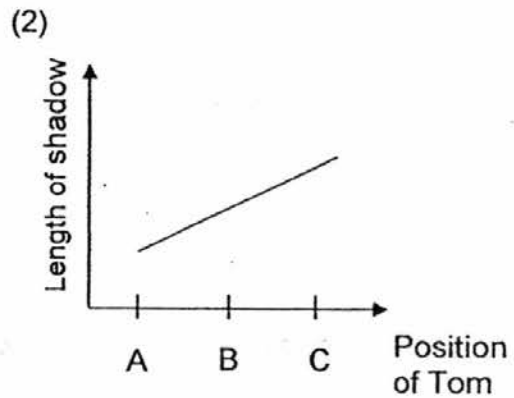
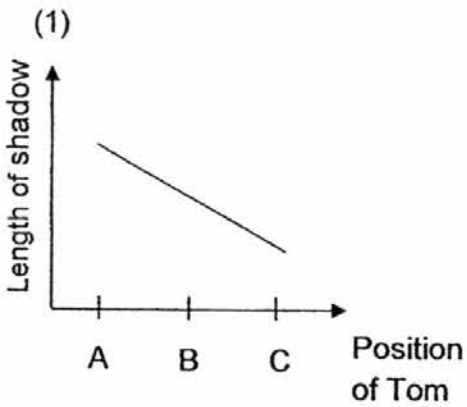

27. Mina placed some ice cubes into a cup of hot milk. Which of the following graphs shows the correct change in the temperature of the milk after some time?

(1)

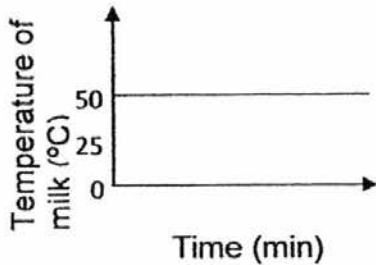

(2)

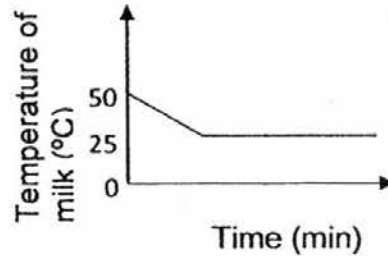

(3)

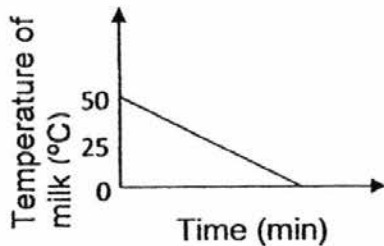

(4)

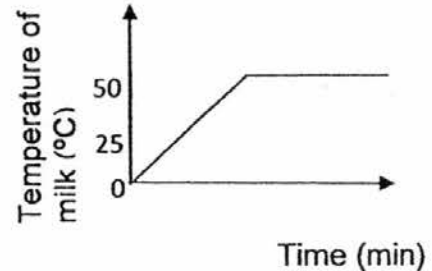

28. Study the 4 beakers of water as shown below.

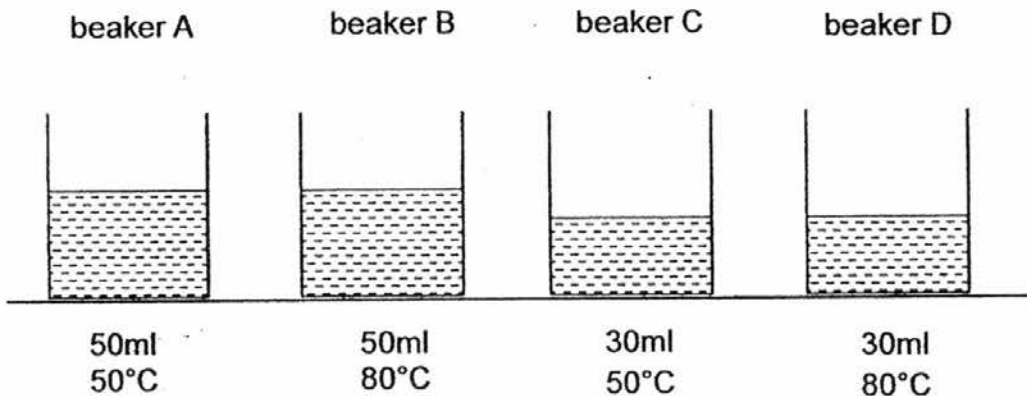

Which one of the following statements is correct about the amount of heat in the beakers of water?

- (1) B has the most amount of heat.
- (2) D has the least amount of water.
- (3) A and C have the same amount of heat.
- (4) B and D have the same amount of heat.

END OF BOOKLET A



Rosyth School
Second Semestral Examination for 2016
SCIENCE
Primary 4

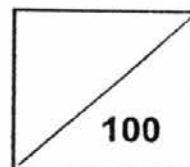

Name: _____

Total
Marks:

Class: Pr 4 _____ Register No. _____

Duration: 1 h 45 min

Date: 25th October 2016

Parent's Signature: _____

Booklet B

Instructions to Pupils:

1. For questions 29 to 44, give your answers in the spaces given in this Booklet B.

	Maximum	Marks Obtained
Booklet A	56 marks	
Booklet B	44 marks	
Total	100 marks	

* This booklet consists of 15 pages.

Booklet B (44 marks)

For questions 29 to 44, write your answers in this booklet.

29. Fill in the correct parts of a plant to match its functions. [2]

Function of plant part	Plant part
It holds the plant upright.	
It obtains water for the plant.	

30. The diagram below shows the human digestive system.

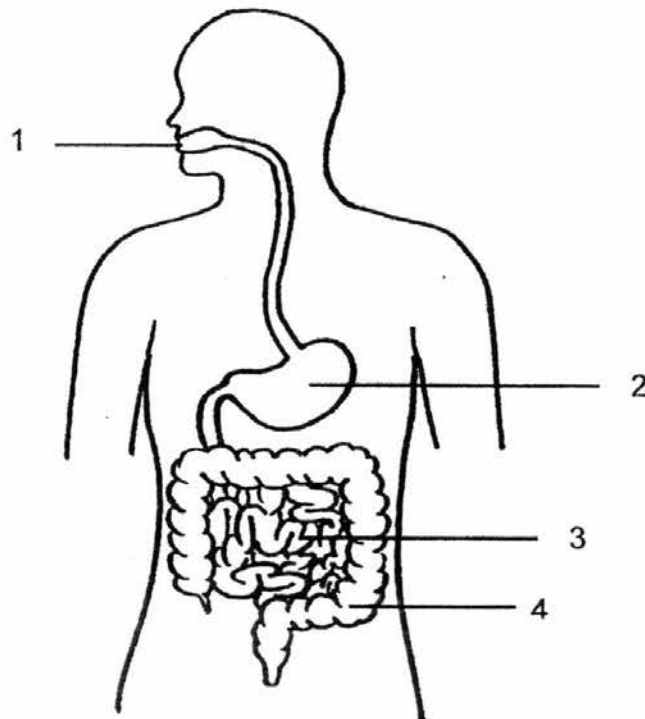

Write the number 1, 2, 3 or 4 in the space below. Identify the part where

(a) digestion first takes place _____ [1]

(b) no digestive juices are produced _____ [1]

31. The diagram below shows a pair of goggles.



- (a) Part X is made of clear plastic because it allows _____ to pass through to help the swimmer see under water. [1]
- (b) Part Y is made of _____ because Y has to be flexible. [1]

32. The diagram below shows a cup of hot coffee.

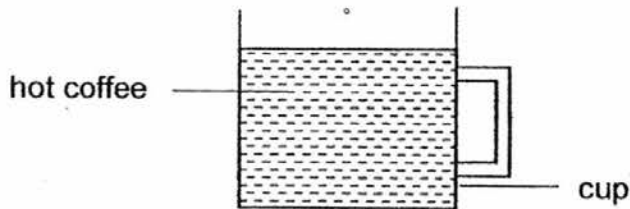

Complete the sentences to state if the parts are solid, liquid or gas.

- (a) The hot coffee is a _____ . [1]
- (b) The cup is a _____ . [1]

33. Choose the correct word from the box to answer the questions below.

magnetic	push	hard	pull
----------	------	------	------

Susan places a magnet near an iron nail. The iron nail moves towards the magnet.



iron nail

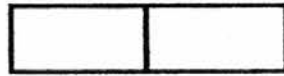

magnet

(a) The magnet exerts a _____ on the iron nail. [1]

(b) Susan's observation shows that iron is a _____ material. [1]

34. Read a part of the newspaper report below.

.....

! A big earthquake struck an island near Singapore, causing a giant tidal wave
! to sweep across the land. Thousands of people were seen running from the
! huge waves. Many did not survive.
L

(a) Based on the report above, state two characteristics of living things observed. [2]

(i) _____

(ii) _____

(b) What do living things need in order to survive? [1]

35. The diagrams below show an ant and a bee.



ant



bee

(a) State one difference and one similarity between the 2 animals above. [2]
(Do not compare their size and colour.)

Difference:

Similarity:

(b) Do you think a bird can be placed in the same group as the ant and bee? Explain why. [1]

36. Kelly set up an experiment to investigate the life cycle of butterfly W. She wanted to find out if the number of days taken for the egg to develop into an adult is affected by the amount of time exposed to light.

Set-up	A	B	C
Amount of time exposed to light	6	12	18
Number of days taken for the egg to develop to an adult	30	15	10

- (a) State the relationship between the amount of time exposed to light and the number of days taken for the egg to develop to an adult. [1]

- (b) Based on the results, what can be done to increase the number of adults of W? [1]

- (c) Explain why for your answer in part (b). [1]

37. The diagram below shows plant A.

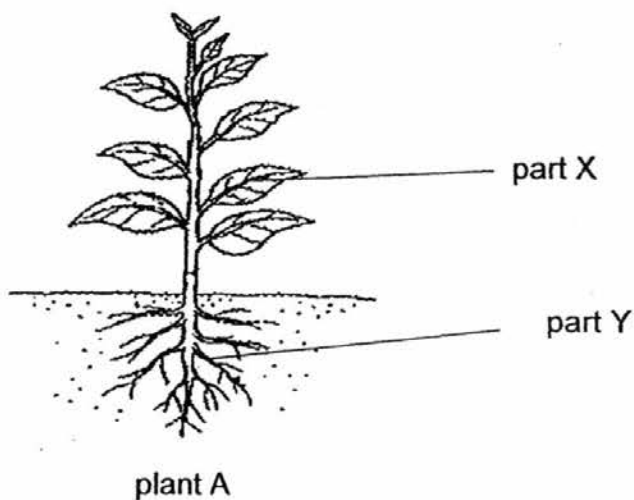

(a) Name of part X. [1]

(b) State the main function of part X. [1]

(c) State two substances from the soil that is taken in by part Y of the plant. [2]

(i) _____

(ii) _____

38. The flow chart below shows the pathway of food in the human digestive system.

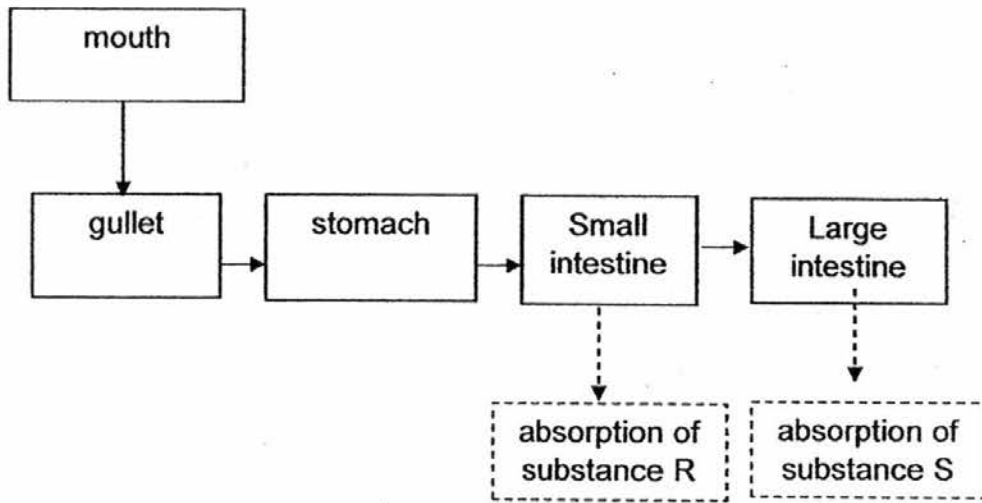

- (a) Identify substances R and S in the flowchart. [2]

R: _____

S: _____

- (b) If a person did not chew the food enough, how will it affect the time taken to complete digestion? [1]

39. Julia grouped some objects according to the classification table below.

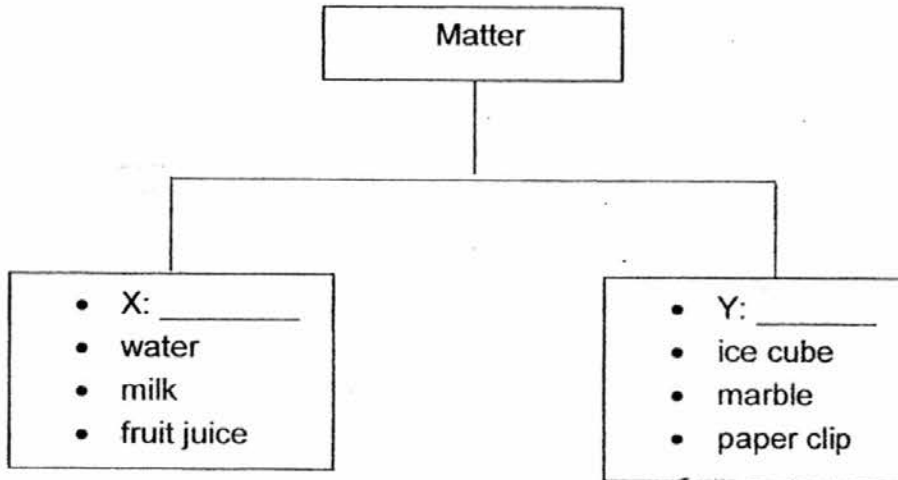

(a) Suggest a suitable heading for X and Y based on the properties of the items in each box. [2]

X: _____

Y: _____

(b) Julia wanted to place 'oxygen' in group X. Do you agree with her? Explain why. [1]

40. Rachel prepared the following set-up. She closed the switch and observed the steel paper clip 'floating' in the air.

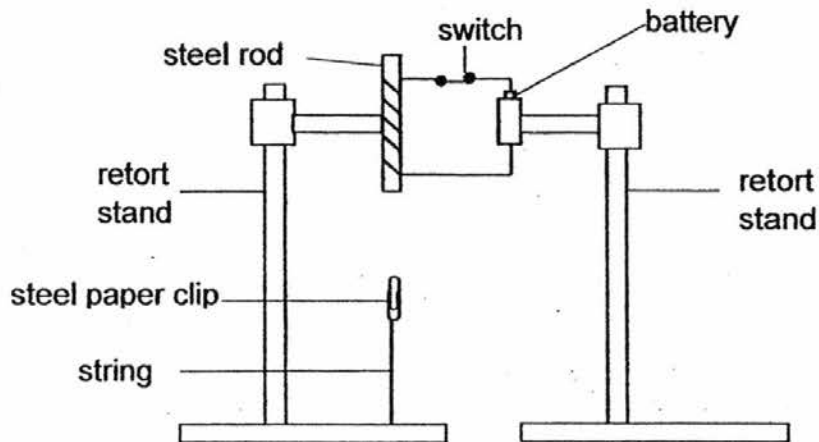

- (a) Explain why the steel paper clip remained 'floating' in the air. [1]

Rachel decided to use a heavier paper clip of the same material for the set up. However the paper clip could not 'float' in the air.

- (b) State two ways in which she can try to make the heavier paper clip 'float' in the air. [2]

(i)

(ii)

41. Gavin set up an experiment to find out the degree of transparency of 3 different types of objects (X, Y and Z). The diagram below shows the set-up he had prepared.

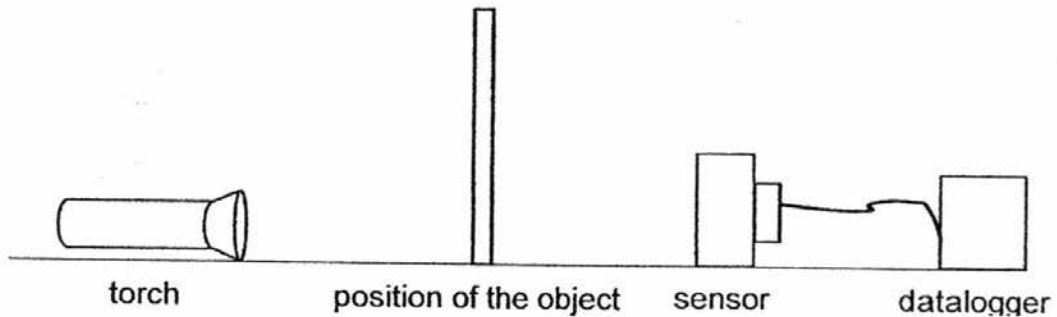

He switched on the torch and datalogger and placed the first object. He left the first object at the position for 10 seconds before changing it to second object and then the third object.

The table below shows the result from his datalogger.

Object	Amount of light detected by datalogger (Lux)
X	0
Y	3000
Z	1500

- (a) Based on the results above, write the objects (X, Y and Z) from one that allows most light to pass through to the one that does not allow light to pass through. [1]

(allows most light to pass through)

(does not allow light to pass through)

Question 41 continues on page 11

- (b) Identify and tick (✓) the correct variables shown in the table below. [2]

Type of variables	Changed variable	Variable kept the same
(i) Type of object		
(ii) Distance between the torch and the object.		
(iii) Amount of light		
(iv) Time taken to measure the amount of light passing through the object..		

42. Diagram 1 below shows the shadow of an object on a screen.

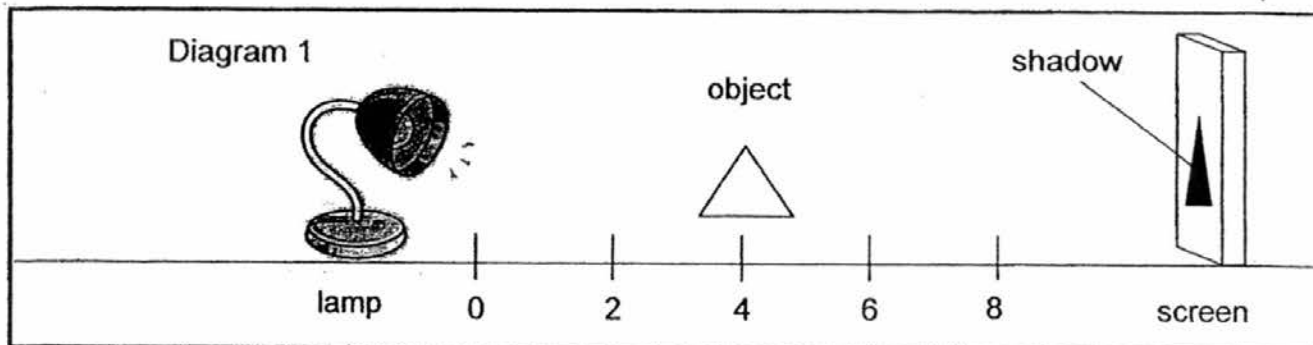

(a) A bigger shadow was observed after the object was moved. Draw a \triangle to show the new position of the object in Diagram 2 below. [1]

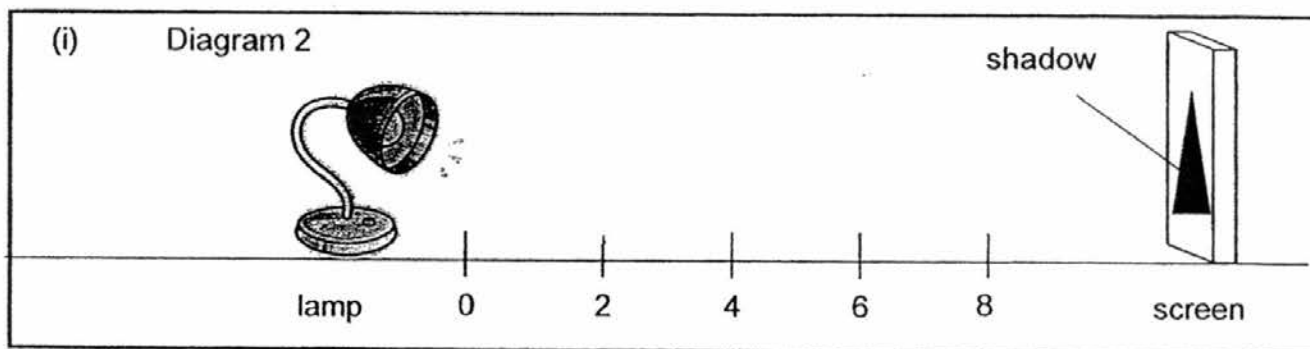

A smaller shadow than diagram 1 was observed after the object was moved again. Draw a \triangle to show the new position of the object in Diagram 3 below. [1]

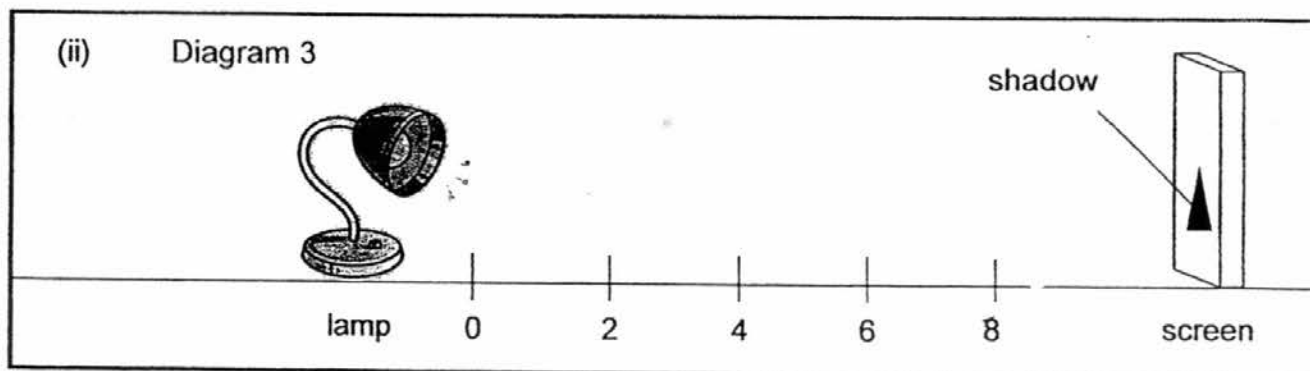

(b) State 2 properties of light which causes shadow to be formed. [2]

Property 1: _____

Property 2: _____

43. The diagram below shows two glasses stuck together.

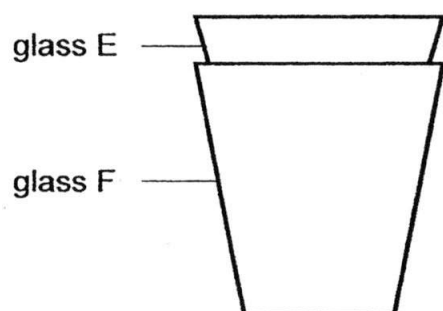

(a) Given a basin of hot water as shown below, state a way the two glasses can be separated? [1]

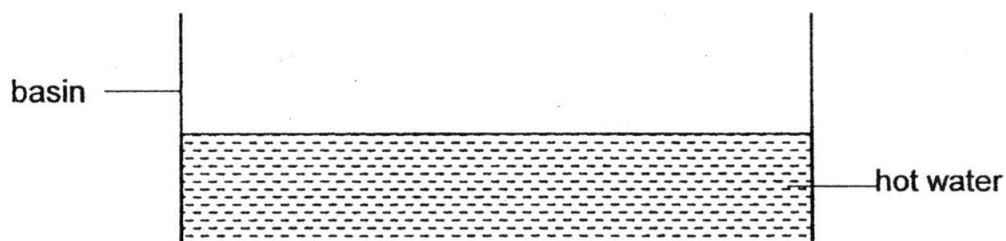

(b) Explain your answer in (a). [1]

44. Lily filled 4 glasses with equal amount of water at 70°C each. Each glass was wrapped using different materials. After 15 minutes, the temperature of water in each glass was measured. The table below shows the results.

Material wrapped around the glass	Temperature of water after 15 minutes (° C)
A	25
B	40
C	35
D	60

- (a) Why do you think the temperature of water decreased in all the glasses? [1]

Lily wanted to choose a material to wrap a block of ice to prevent it from melting quickly.

- (b) Which Material A, B, C or D will Lily choose? Explain why? [2]

End of Paper

YEAR : 2016
 LEVEL : PRIMARY 4
 SCHOOL : ROSYTH
 SUBJECT : SCIENCE
 TERM : SA2

Booklet A

Q1	1	Q5	2	Q9	4	Q13	2	Q17	2	Q21	2	Q25	2
Q2	4	Q6	4	Q10	3	Q14	3	Q18	3	Q22	1	Q26	3
Q3	1	Q7	2	Q11	4	Q15	3	Q19	3	Q23	2	Q27	2
Q4	2	Q8	3	Q12	3	Q16	4	Q20	2	Q24	3	Q28	1

Booklet B

Q29

Function of plant part	Plant part
It holds the plant upright.	Stem
It obtains water for the plant	Root

- Q30 (a) digestion first takes place : 1
 (b) no digestion juices are produced : 4
- Q31 (a) Part X is made of clear plastic because it allows light to pass through to help the swimmer see under water.
 (b) Part Y is made of rubber because Y has to be flexible.
- Q32 (a) The hot coffee is a liquid.
 (b) The cup is a solid.
- Q33 (a) The magnet exerts a pull on the iron nail.
 (b) Susan's observation shows that iron is a magnetic material.
- Q34 (a) (i) Living things respond to changes.
 (ii) Living things die.
 (b) Living things need air, food and water.

- Q35 (a) **Difference : The bee has a hairy body but the ant does not /
The bee has a pair of wings but the ant does not have a pair of wings.**
- Similarity : Both the bee and ant have 6 legs.**
- (b) **Yes. Because all of them lay eggs.
No. A bird has 2 legs but an ant has 6 legs.**
- Q36 (a) **The more time the egg is exposed to light, the shorter time taken to develop to an adult.**
- (b) **Increase the time exposed to light.**
- (c) **The egg will develop into an adult quicker so more reproduction will happen in a short span of time.**
- Q37 (a) **Leaves**
- (b) **It produces food for the plant.**
- (c) (i) **Water**
- (ii) **Mineral salts**
- Q38 (a) **R : Digested food**
- S : Water**
- (b) **It will take a longer time to complete digestion.**
- Q39 (a) **X : Has no definite shape.**
- Y : Has definite shape.**
- (b) **Yes. They have both indefinite shape.**
- Q40 (a) **The steel paper clip is attracted to the electromagnet.**
- (b) (i) **Add more coils around the steel rod.**
- (ii) **Add more batteries.**

Q41

(a)

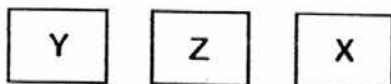

(b)

Type of variables	Changed variable	Variable kept the same
(i) Type of object	✓	
(ii) Distance between the torch and the object.		✓
(iii) Amount of light		✓
(iv) Time taken to measure the amount of light passing through the object.		✓

Q42

(a) (i)

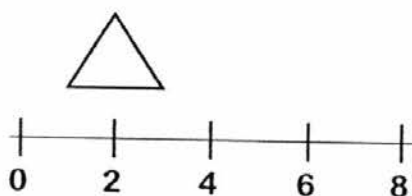

(ii)

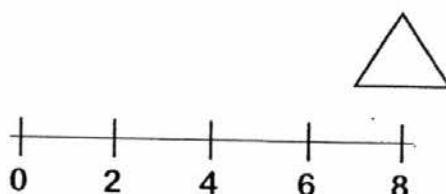

(b) Property 1 : Light travels in straight lines.

Property 2 : Shadows are formed when light is completely blocked by an opaque object.

Q43

(a) Put glass F in the basin of hot water.

(b) Glass F will expand as it gains heat, hence separated.

Q44

(a) All the glasses lost heat to the surrounding air around them.

(b) Material D. The temperature of water decreased the least, so it is the poorest conductor of heat.

End