



**NAN HUA PRIMARY SCHOOL
SEMESTRAL ASSESSMENT 1 – 2015
PRIMARY 5**

MATHEMATICS

Paper 1

Section A: 15 Multiple Choice Questions (20 marks)

Section B: 15 Short Answer Questions (20 marks)

Total Time for Paper 1: 50 minutes

INSTRUCTION TO CANDIDATES

1. Write your name and index number in the space provided.
2. Do not turn over the page until you are told to do so.
3. Follow all instructions carefully.
4. Answer all questions.
5. Shade your answers in the Optical Answer Sheet (OAS) provided for Questions 1-15.
6. You are not allowed to use the calculator for Paper 1.

Marks Obtained

Paper 1	Booklet A		/ 40
	Booklet B		
Paper 2			/ 60
Total			/ 100

Name : _____ ()

Class : 5 _____

Date : 13 May 2015 **Parent's Signature:** _____

Section A (20 marks)

Questions 1 to 10 carry 1 mark each. Questions 11 to 15 carry 2 marks each.
For each question, four options are given. One of them is the correct answer.
Make your choice (1, 2, 3 or 4) and shade on the oval (1, 2, 3 or 4) on the Optical Answer Sheet (OAS).

1. Which one of the following has the digit '7' in the ten thousands' place?
 - (1) 409 781
 - (2) 704 198
 - (3) 847 190
 - (4) 970 841

2. Find the value of $20 + (40 - 16) \div 2$.
 - (1) 14
 - (2) 22
 - (3) 32
 - (4) 52

3. Mrs Tan's monthly salary became \$5 500 when rounded off to the nearest hundreds. Which one of the following could be Mrs Tan's actual monthly salary?
 - (1) \$5 425
 - (2) \$5 450
 - (3) \$5 550
 - (4) \$5 565

4. Which one of the following has the same value as $\frac{6}{7} \div 4$?

(1) $\frac{3}{14}$

(2) $\frac{7}{24}$

(3) $3\frac{3}{7}$

(4) $4\frac{2}{3}$

5. How many eighths are there in $7\frac{1}{2}$?

(1) 10

(2) 15

(3) 57

(4) 60

6. Which one of the following shapes has only 2 lines of symmetry?

(1)

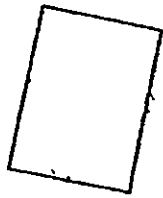

(2)



(3)



(4)

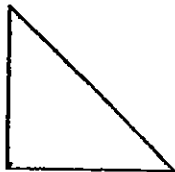

7. Which one of the following is equivalent to 7 : 9?

(1) 35 : 45

(2) 35 : 54

(3) 28 : 32

(4) 28 : 45

8. The figure below, not drawn to scale, shows a shaded triangle ABC. If the base of triangle ABC is AB, which one of the following is its corresponding height?

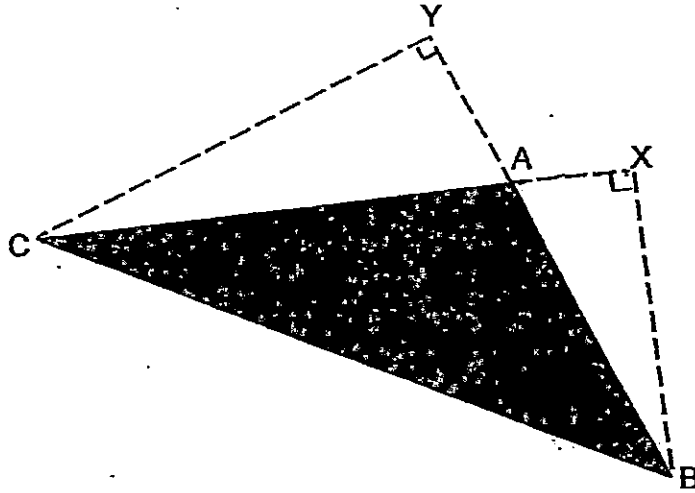

- (1) AC
(2) AY
(3) BX
(4) CY
9. Ali and Baba received 272 sweets in the ratio 3 : 5 respectively.
How many more sweets did Baba receive than Ali?
- (1) 170
(2) 102
(3) 68
(4) 34

10. Alice's mass is $\frac{5}{9}$ of Donald's mass. What is the ratio of Alice's mass to their total mass?

- (1) 5 : 9
- (2) 5 : 14
- (3) 9 : 5
- (4) 9 : 14

11. Jason spent $\frac{3}{7}$ of his money on a toy and $\frac{3}{8}$ of his remaining money on a calculator. He then found out that he had \$35 left. How much money did he have at first?

- (1) \$21
- (2) \$42
- (3) \$63
- (4) \$98

12. Some letters are arranged in the following pattern:

L O V E L O V E L O V E ...

1st

What will be the 100th letter?

(1) L

(2) O

(3) V

(4) E

13. A bus can either seat 36 children or 20 adults. If there are already 5 children and 6 adults on the bus, what is the most number of additional children that can still be seated in the bus?

(1) 14

(2) 16

(3) 22

(4) 31

Section B (20 marks)

Questions 16 to 25 carry 1 mark each. Write your answers in the spaces provided. For questions which require units, give your answers in the units stated.

16. Arrange the following fractions in ascending order.

$$\frac{17}{4}, \frac{39}{8}, \frac{9}{2}$$

Ans: _____, _____, _____
Smallest \longrightarrow Biggest

17. $1895 \div \boxed{?} = 18.95$

Ans: _____

18. What is the sum of all the factors of 49?

Ans: _____

19. What is 24 : 32 in its simplest form?

Ans: _____

20. What is 51.095 when rounded off to 2 decimal places?

Ans: _____

21. What is the ratio of 15 metres to 2 kilometres? Give your answer in the simplest form.

Ans: _____

22. In the figure below, how many **more** circles must be shaded such that the number of shaded circles is $\frac{2}{3}$ the total number of circles?

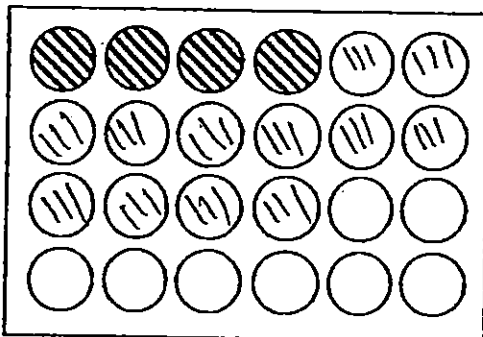

Ans: _____

23. What is the missing sign (+, −, ×, ÷) in the box below?

$$20 \times (10 \boxed{?} 5) = 100$$

Ans: _____

24. Using the number cards provided below, form the **smallest** 4-digit odd number. Each digit can only be used once.



Ans: _____

25. Jenny had some stickers. She kept $\frac{1}{9}$ of her stickers and gave the remaining stickers to 4 friends equally. What fraction of all the stickers did each friend receive?

Ans: _____

Questions 26 to 30 carry 2 marks each. Show your working clearly in the space provided for each question and write your answers in the spaces provided. For questions which requires units, give your answers in the units stated.

Do not write
in this space

26. In the number line below, find the fraction exactly halfway between $\frac{1}{5}$ and $\frac{1}{3}$.

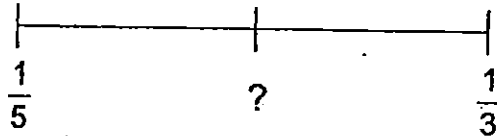

Ans: _____

27. A string is 1.82m longer than a rope. The rope is 3 times as long as a thread. If the total length of the string, rope and thread is 12.6m, find the length of the thread.

Ans: _____ m

28. Joyce had $\frac{5}{6}$ as many pens as Ben. Eric had $\frac{1}{2}$ as many pens as Ben.
Express Joyce's number of pens as a fraction of the total number of pens.

Ans: _____

29. The ratio of Jack's money to Dave's money was 2 : 5. They had a total of \$196. After Jack received another \$64 from his mother, what was the new ratio of Jack's money to Dave's money?
Give your answer in the simplest form.

Ans: _____

30. Some potted plants were planted along the perimeter and at each corner of a square garden. Each potted plant was evenly spaced at 2m apart. Given that the perimeter of the garden was 64m, what was the total number of potted plants planted?

Do not write
in this space

Ans: _____

END OF PAPER 1



**NAN HUA PRIMARY SCHOOL
SEMESTRAL ASSESSMENT 1 – 2015
PRIMARY 5**

MATHEMATICS

Paper 2

Total Time for Paper 2: 1 hour 40 minutes

5 Short Answer Questions (10 marks)

13 Structured / Long Answer Questions (50 marks)

INSTRUCTION TO CANDIDATES

1. Write your name and index number in the space provided.
2. Do not turn over the page until you are told to do so.
3. Follow all instructions carefully
4. Answer all questions and show your workings clearly.
5. You are allowed to use a calculator.

Marks Obtained

Total		/ 60
--------------	--	-------------

Name : _____ ()

Class : 5 _____

Date : 13 May 2015

Parent's Signature : _____

Paper 2 (60 marks)

Do not write
in this space

Questions 1 to 5 carry 2 marks each. Show your workings clearly in the space below it and write your answer in the space provided. Give your answers in the units stated.

1. Beatrice paid \$18 for 1 book and 6 similar pens. The book cost thrice as much as a pen. How much did a pen cost?

Ans: \$ _____

2. In a bakery shop, cupcakes were sold only in boxes of 6 and each box cost \$13. What was the most number of cupcakes a customer could buy with \$240?

Ans: _____

3. Aini and Bobby had a sum of money each.

$\frac{3}{4}$ of Aini's money was equal to $\frac{5}{8}$ of Bobby's money.

What was the ratio of Bobby's total sum of money to Aini's total sum of money? Give your answer in the simplest form.

Ans: _____

4. The figure below is not drawn to scale. $AB = 14$ cm, $BM = 20$ cm and BM is perpendicular to AB . The area of triangle DEC is $\frac{2}{7}$ of the area of triangle ABC . What is the area of triangle DEC ?

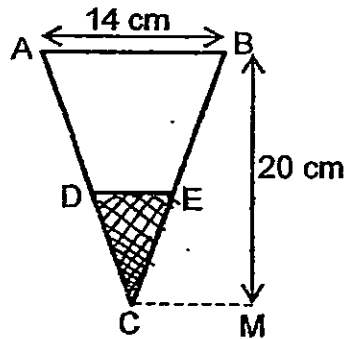

Ans: _____ cm²

Do not write
in this space

5. The table below shows the charges for parking a car in Shopping Centre A.

First hour	\$7
For every additional half hour or part thereof	\$1

How much did Mr Lim pay if he parked his car in Shopping Centre A for 5 hours and 15 minutes?

Ans: \$ _____

For questions 6 to 18, show your working clearly in the space provided for each question and write your answers in the spaces provided. The number of marks available is shown in brackets [] at the end of each question or part-question.

Do not write
in this space

6. Mrs Tan bought 96 eggs. She put half the eggs equally into 6 trays and the other half equally into 4 containers. How many eggs were there in 3 trays and 1 container?

Ans: _____ [3]

7. The ratio of Richard's money to Mel's money was 1 : 7. How much money must Mel give to Richard so that each of them will have \$104?

Ans: _____ [3]

Do not write
in this space

8. James gave $\frac{7}{12}$ of his money to his mother and spent $\frac{3}{10}$ of the remaining money on a T-shirt. He saved the rest.

- (a) What fraction of his money did he spend on the T-shirt?
Express your answer in the simplest form.
- (b) If he saved \$105, how much money did he have at first?

Ans: (a) _____ [1]

(b) _____ [2]

9. Daphne had 30 stamps more than Paul at first. After Daphne gave Paul 42 stamps, Paul had thrice as many stamps as Daphne.
How many stamps did Daphne have at first?

Ans: _____

10. The figure below is not drawn to scale. All the lines meet at right angles.

(a) Find the perimeter of the figure.

(b) Find the area of the figure.

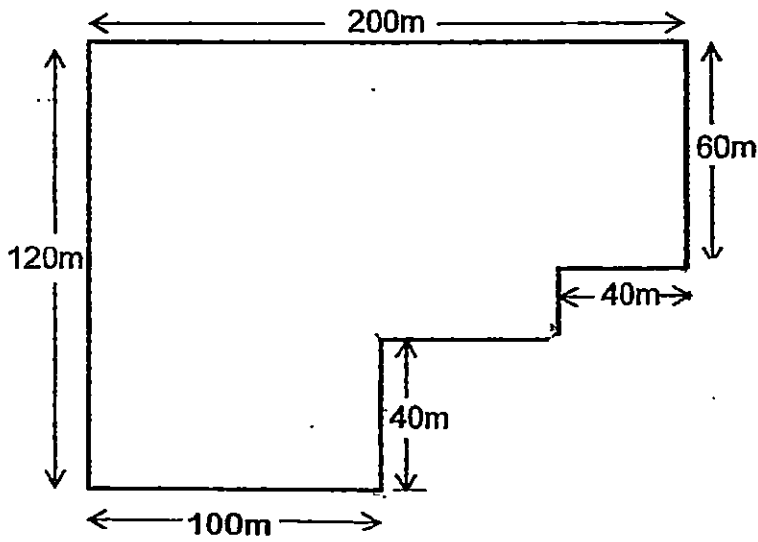

Do not write
in this space

Ans: (a) _____ [1]

(b) _____ [2]



Do not write
in this space

11. A packet of flour cost \$2. A packet of chocolate powder cost \$3 more. Mrs Lim bought twice as many packets of flour as chocolate powder. She paid \$189 in total. How many packets of flour did Mrs Lim buy?

Ans: _____ [4]

12. At a fruit stall, the ratio of the number of apples to the number of oranges was 5 : 3. There were 600 more apples than oranges. The apples were sold at 3 for \$1 and the oranges were sold at 5 for \$2. What was the total amount of money collected from the sale of all the apples and oranges?

Ans: _____ [4]

13. Belinda had 159 beads. Emily had 282 beads. After both girls gave away an equal number of beads, Belinda had $\frac{2}{5}$ as many beads as Emily. How many beads did Belinda and Emily give away altogether?

Ans: _____ [4]

14. The figure below, not drawn to scale, is made up of a triangle overlapped with a rectangle. The area of the triangle is $\frac{1}{3}$ the area of the rectangle. Given that $\frac{2}{5}$ of the triangle is shaded and the total area of the unshaded parts is 2400 cm^2 , what is the area of the figure?

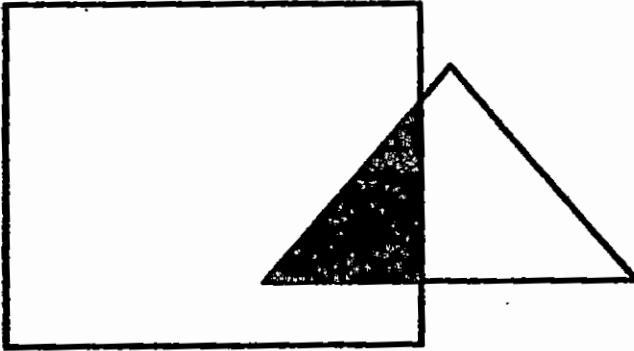

Do not write
in this space

Ans: _____ [4]

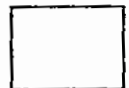

15. Study the pattern carefully and answer the questions that follow.

Do not write
in this space

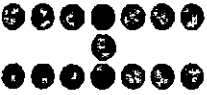
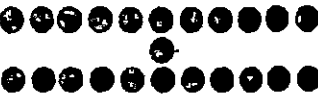
Pattern 1	Pattern 2	Pattern 3
		

- (a) How many dots are there in Pattern 4?
- (b) How many dots are there in Pattern 10?
- (c) In which pattern would there be 791 dots?

Ans: (a) _____ [1]
 (b) _____ [1]
 (c) _____ [2]

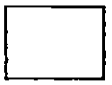

16. The total cost of 9 similar necklaces and 5 similar earrings was \$1440.
The total cost of 2 such necklaces and 3 such earrings was \$439.
Find the total cost of 1 necklace and 1 earring.

Do not write
in this space

Ans: _____ [5]

17. Alex and Billy had some game cards.

If Billy gave Alex 45 game cards, they would have an equal number of game cards.

If Alex gave Billy 145 game cards, Billy would have 5 times as many game cards as Alex.

(a) How many game cards did Billy have?

(b) How many game cards did Alex have?

Do not write
in this space

Ans: (a) _____ [3]

(b) _____ [2]

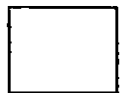

18. There are 162 buttons in Box A, Box B and Box C altogether. Some buttons are first transferred from Box A to Box B, causing Box B's number of buttons to be tripled.
 $\frac{1}{4}$ of Box B's buttons are then transferred from Box B to Box C. Finally, 24 buttons are transferred from Box C to Box A. There is an equal number of buttons in each box at the end. Find the number of buttons in each box at first.

Do not write
in this space

Ans: Box A: _____

Box B: _____

Box C: _____ [5]



END OF PAPER 2



EXAM PAPER 2015

LEVEL : PRIMARY 5

SCHOOL : NAN HUA PRIMARY

SUBJECT : MATHEMATICS

TERM : SA1

Q1	Q2	Q3	Q4	Q5	Q6	Q7	Q8	Q9	Q10
4	3	2	1	4	1	1	4	3	2
Q11	Q12	Q13	Q14	Q15					
4	4	3	2	2					

Q16. Smallest \rightarrow Biggest $\rightarrow \frac{17}{4}, \frac{9}{2}, \frac{39}{8}$

Q17. 100

Q18. $57 \rightarrow 1,7,49, 50 + 7 = 57$

Q19. 3:4

Q20. 51 : 10

Q21. $3:400 \rightarrow \frac{15}{2000} = \frac{3}{400}, \frac{3}{400} = 3:400$

Q22. $12 \rightarrow 4 \times 6 = 24, \frac{2}{3} = \frac{16}{24}, 24 - 16 = 8$

Q23. - (minus)

$$20 \times (10 - 5) = 100$$

$$20 \times 5 = 100$$

Q24. 2457

Q25. $\frac{2}{9} \rightarrow \frac{8}{9} \div 4 = \frac{8}{9} \times \frac{1}{4} = \frac{2}{9}$

Q26. $\frac{4}{15}$

$$\frac{1}{5} = \frac{3}{15}$$

$$\frac{1}{3} = \frac{5}{15}$$

$$\frac{3}{15} + \frac{5}{15} = \frac{8}{15}$$

$$\frac{8}{15} \times \frac{1}{2} = \frac{4}{15}$$

Q27. 1.54m

$$12.6\text{m} - 1.82\text{m} = 10.78\text{m}$$

$$10.78\text{m} \div 7 = 1.54\text{m}$$

Q28. $\frac{5}{14}$

$$5 + 6 + 3 = 14$$

Joyce : total no. of pens, 5:14

Q29. 6:7

Jack : Dave

2 : 5

$$\$196 \div 7 = \$28$$

$$\$28 \times 2 + \$64 = \$120 \text{ (Jack in the end)}$$

$$\$28 \times 5 = \$140$$

Jack : Dave

120 : 140

12 : 14

6 : 7

Deliver 335x

Q30. 32

$$64 \div 4 = 16$$

$$16 \div 2 = 8 \text{ (gaps)}$$

$$8 + 1 = 9 \text{ (potted plant of each side)}$$

$$9 \times 4 = 36$$

$$36 - 4 = 32 \text{ (minus potted plant at four sides)}$$

Q1. \$2

1 book = 3pens

$$6 + 3 = 9$$

$$\$18 \div 9 = \$2$$

Q2. 108

$$\$240 \div 13 = 18R6$$

$$18 \times 6 = 108 \text{ (no. of cupcakes)}$$

Q3. 6:5

$$\frac{3}{4} \text{ of Aini} = \frac{5}{8} \text{ of Bobby}$$

$$\frac{15}{20} \text{ of Aini} = \frac{15}{24} \text{ of Baby}$$

Bobby : Aini

24 : 20

12 : 10

6 : 5

Q4. 40cm²

$$14 \times 20 \times \frac{1}{2} = 140 \text{ (Area of Triangle ABC)}$$

$$140 \div 7 \times 2 = 40 \text{ (Area of Triangle DEC)}$$

Q5. \$16

$$5\text{hr} - 1\text{hr} = 4\text{hr}$$

4 hours \rightarrow 8 half hour

$$8 \times \$1 = 48$$

$$\$8 + \$1 + \$7 = \$16$$

Q6. 36

$$96 \div 2 = 48$$

$$48 \div 6 = 8 \text{ (each tray)}$$

$$48 \div 4 = 12 \text{ (each container)}$$

$$8 \times 3 = 24 \text{ (3 trays)}$$

$$24 + 12 = 36 \text{ (3 trays & 1 container)}$$

Q7. \$78

Richard : Mel

1 : 7

Difference Total

6 units 8 units

Each just have 4 units to be equal

$$\$104 \div 4 = \$26$$

$$7 \text{ units} - 4 \text{ units} = 3 \text{ units}$$

$$\$26 \times 3 = \$78$$

Q8a. $\frac{1}{8} \rightarrow \frac{3}{24} = \frac{1}{8}$

Q8b. \$360

$$\$105 \div 7 = \$15$$

$$\$15 \times 24 = \$360$$

$$\frac{5}{12} \times \frac{7}{10} = \frac{7}{24}$$

Q9. 69

$$12 + 30 + 12 = 54$$

$$2 \text{ units} \rightarrow 54$$

$$1 \text{ unit} \rightarrow 27$$

$$27 + 12 + 30 = 69$$

Q10a. 640m $(1200 + 120) \times 2 = 640$

Q10b. 19,200m²

$$200 \times 120 = 24,000$$

$$60 \times 40 = 2400$$

$$40 \times 60 = 2400$$

$$24,000 - 2400 - 2400 = 19,200$$

Q11. 42

$$\$2 + 43 = \$5 \text{ 1 packet of chocolate powder)}$$

$$\$2 \times 2 = \$4$$

$$\$4 + \$5 = \$9$$

$$\$189 \div \$9 = 21 \text{ (sets)}$$

$$21 \times 2 = 42 \text{ (packets of flour)}$$

Q12. \$860
2 units \rightarrow 600
1 unit \rightarrow $600 \div 2 = 300$
5 units \rightarrow $300 \times 5 = 1500$ (No. of apples)
 $1500 \div 3 = 500$
 $500 \times \$1 = \500 (money collected from apples)
3 units \rightarrow $300 \times 3 = 900$
 $900 \div 5 = 180$
 $180 \times \$2 = \360 (more collected from oranges)
 $\$360 + \$500 = \$860$ (altogether)

Q13. 154
3 units 123
1 unit 41
2 units 82 (Belinda in the end)
 $159 - 82 = 77$ (Each girl gave away)
 $77 \times 2 = 154$ (gave away altogether)

Q14. 2700cm^2
 $13 + 3 = 16$
16 parts \rightarrow 2400cm^2
1 part \rightarrow 150cm^2
 $13 + 2 + 3 = 18$ parts
 $150 \times 18 = 2700$

Q15a. $31 \rightarrow 23 + 8 = 31$

Q15b. $79 \rightarrow 10 - 1 = 9, 9 \times 8 = 72, 72 + 7 = 79$

Q15c. $99 \rightarrow 791 - 7 = 784, 784 \div 8 = 98, 98 + 1 = 99$

Q16. \$188
 $27n + 15e = \$4320$
 $10n + 15e = \$2195$
 $17n = \$2125$
 $1n = \$125$
 $2n = \$250$
 $3e = \$189$
 $1e = \$63$
 $\$63 + \$125 = \$188$

Q17a. \$330
 $145 + 90 + 145 = 380$
4 units \rightarrow 4380
1 unit \rightarrow \$95
 $\$95 + 90 = \185
 $\$185 + 4145 = \330

Q17b. \$240

$$\$95 + \$145 = \$240$$

Q18. Box A: 78. Box B: 24 Box C: 60

$$162 \div 3 = 54$$

$$54 + 24 = 78 \text{ (C)}$$

$$54 - 24 = 30 \text{ (A)}$$

$$54 \div 3 = 18$$

$$78 - 18 = 60 \text{ (C)}$$

$$54 + 18 = 72 \text{ (B)}$$

$$72 \div 3 = 24 \text{ (B)}$$

$$72 - 24 = 48$$

$$30 + 48 = 78 \text{ (A)}$$

THE END