

Name: \_\_\_\_\_ ( )

Class: Primary 5 \_\_\_\_\_

## CHIJ ST NICHOLAS GIRLS' SCHOOL



**Primary 5**

**First Continual Assessment – 2011**

**SCIENCE**

**BOOKLET A**

**2<sup>nd</sup> March 2011**

**Total Time for Booklets A and B: 1 hour 45 minutes**

**30 questions**

**60 marks**

**Do not open this booklet until you are told to do so.  
Follow all instructions carefully.  
Answer all questions.**

**This paper consists of 16 printed pages.**

**Section A : (30 x 2 marks)**

For each question from 1 to 30, four options are given. One of them is the correct answer. Mark your choice (1, 2, 3 or 4). Shade the correct oval (1, 2, 3 or 4) on the Optical Answer Sheet.

1. Which of the following statements about life cycles is/are correct?

- A The mealworm looks different from the adult.
- B The young of a cockroach looks like the adult.
- C Some living things have more stages in their life cycles than others.
- D Butterflies have more stages in their life cycles than a mango tree.

- (1) D only
- (2) A and B only
- (3) B and C only
- (4) A, B, C and D

2. Study the life cycle of a bedbug as shown below.

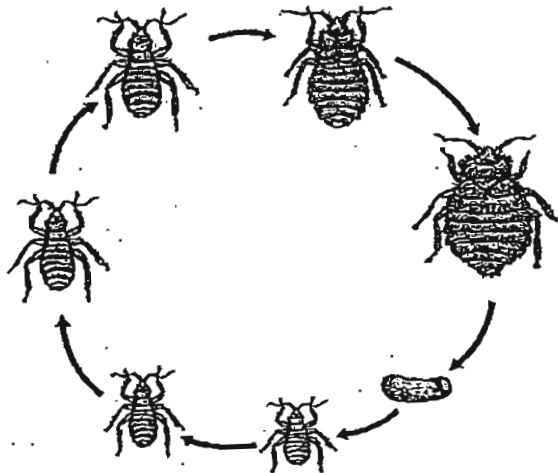

Which of the following statements about the life cycle of the bedbug is/are correct?

- A The young of the bedbug looks like the adult.
- B There are 6 stages in the life cycle of a bedbug.
- C The bedbug undergoes moulting at the nymph stage.

- (1) B only
- (2) A and B only
- (3) A and C only
- (4) B and C only

3. The diagrams below show the different stages in a plant's life cycle.

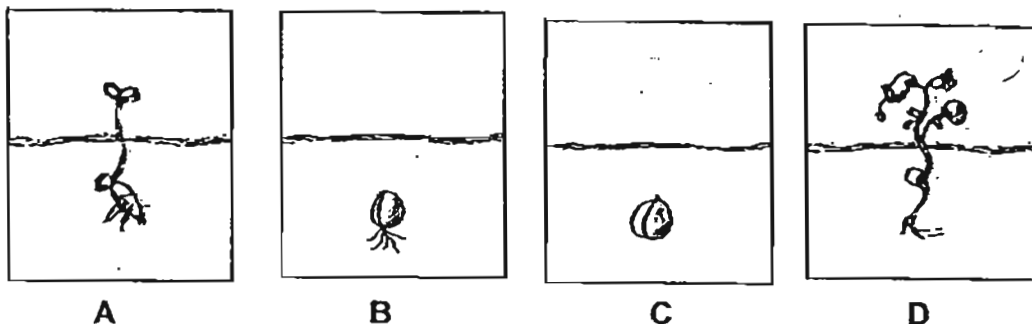

Which one of the following shows the correct sequence of the growth of the plant?

- (1) C, B, A, D
- (2) C, A, D, B
- (3) D, A, B, C
- (4) D, B, A, C

4. Su Ling wanted to find out the conditions required for the balsam seeds to germinate. She set up the following set-ups to investigate.

Set-up	Condition of cotton wool	Location placed
W	Moist	In a cupboard
X	Dry	Near a closed window
Y	Moist	Near a closed window
Z	Moist	In a freezer compartment

Given the different conditions, in which set-up(s) will the balsam seeds start to germinate after two days?

- (1) Set-up W only
- (2) Set-ups W and Y only
- (3) Set-ups X and Y only
- (4) Set-ups X and Z only

5. Study the flow chart below carefully.

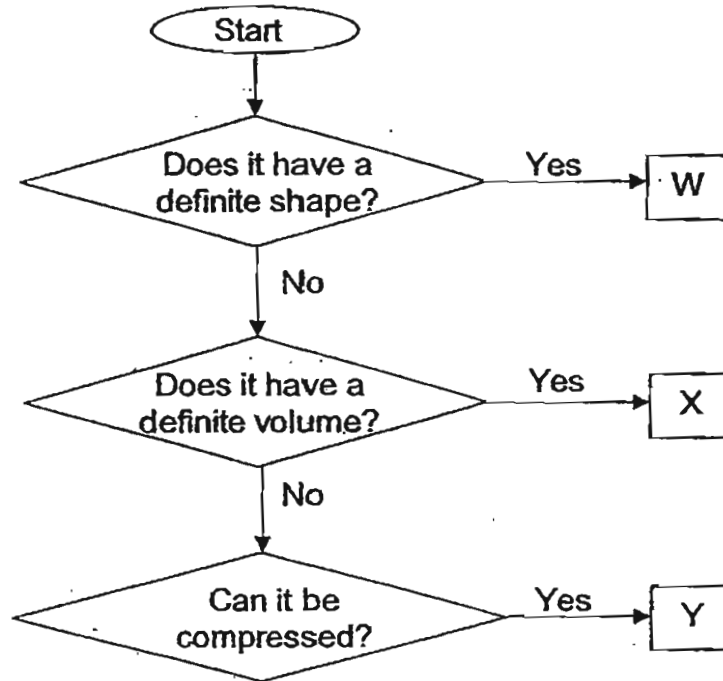

Which of the following can W, X and Y be?

	W	X	Y
(1)	Air	Water	Ice
(2)	Cork	Orange juice	Air
(3)	Book	Air	Water
(4)	Orange Juice	Rain	Air

6. Which of the following is/are not matter?

- A Rain
- B Snow
- C Wind
- D Sunlight

- (1) B only
- (2) D only
- (3) A and B only
- (4) C and D only

7. Mother took a bunch of chilli with a mass of 50g and blended them to make chilli paste. What was the mass of the chilli paste if nothing was added to it during the blending process?

- (1) 40g
- (2) 45g
- (3) 50g
- (4) 65g

8. Study the arrangement of the magnets below. The S-pole of one of the magnets is given as shown in the diagram below.

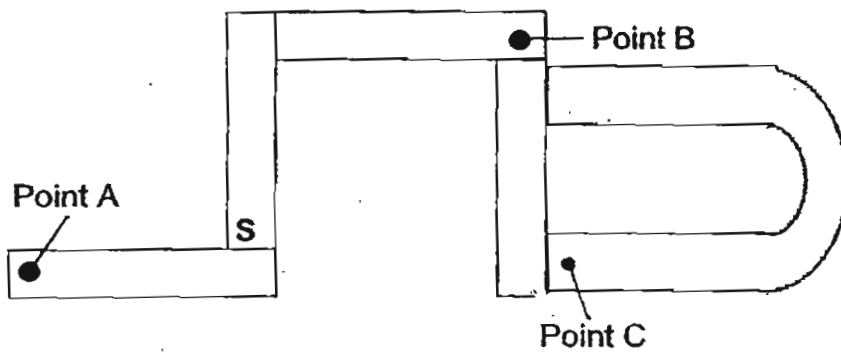

Which one of the following shows the correct poles at points A, B and C respectively?

	Point A	Point B	Point C
(1)	S-Pole	N-Pole	S-Pole
(2)	N-Pole	S-Pole	N-Pole
(3)	S-Pole	S-Pole	S-Pole
(4)	N-Pole	S-Pole	S-Pole

9. Kumar stroked the entire length of an iron nail with a strong bar magnet in the same direction as shown below.

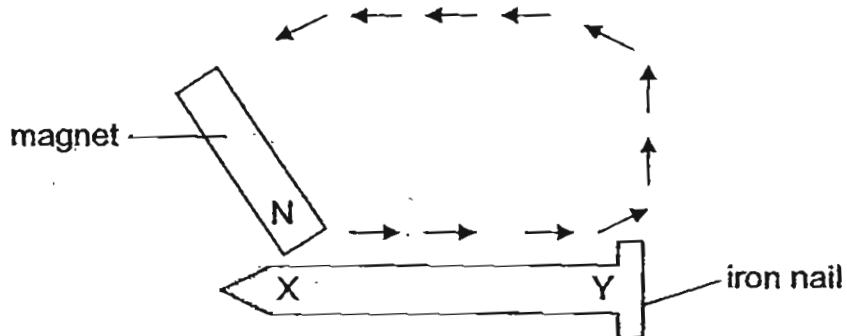

When the nail was magnetized, what poles would X and Y be?

	Point X	Point Y
(1)	North pole	North pole
(2)	North pole	South Pole
(3)	South Pole	North pole
(4)	South Pole	South Pole

10. Shi Shi used some toothpicks, two magnets and two styrofoam boards to set up an experiment as shown below.

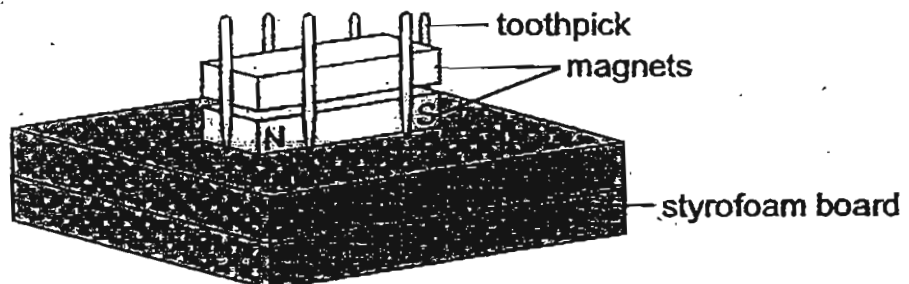

She noticed that the upper magnet was suspended in the air. What could be the cause for such an observation?

- (1) The two magnets are repelling each other.
- (2) The two magnets are attracting each other.
- (3) The two magnets are attracted to the toothpicks.
- (4) The two magnets are attracting and repelling each other at the same time.

11. The diagram below shows how three metal bars, T, U and V, interact with one another.

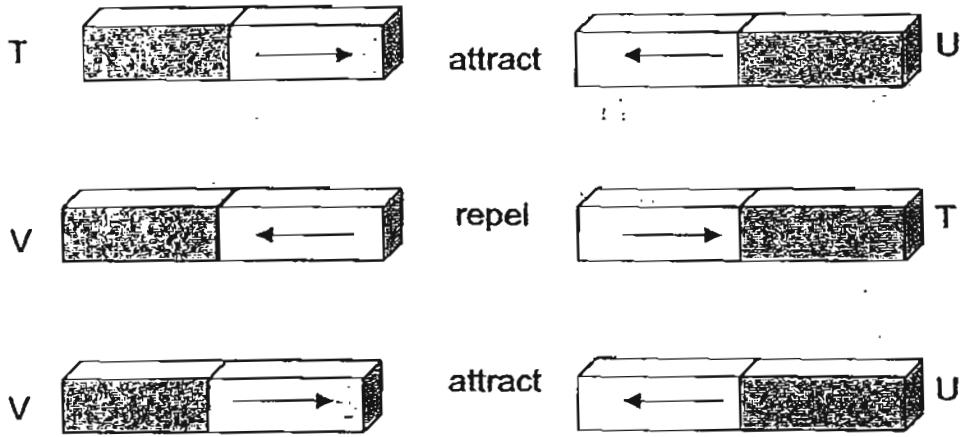

Based on the observations above, which of the metal bars is/are most likely to be a bar magnet?

- (1) U only
- (2) T and V only
- (3) T and U only
- (4) V and U only

12. A magnet which was suspended using a thread. The magnet attracted four paper clips on one end as shown below. When a burner was brought near to heat the other end of the magnet, three of the paper clips dropped.

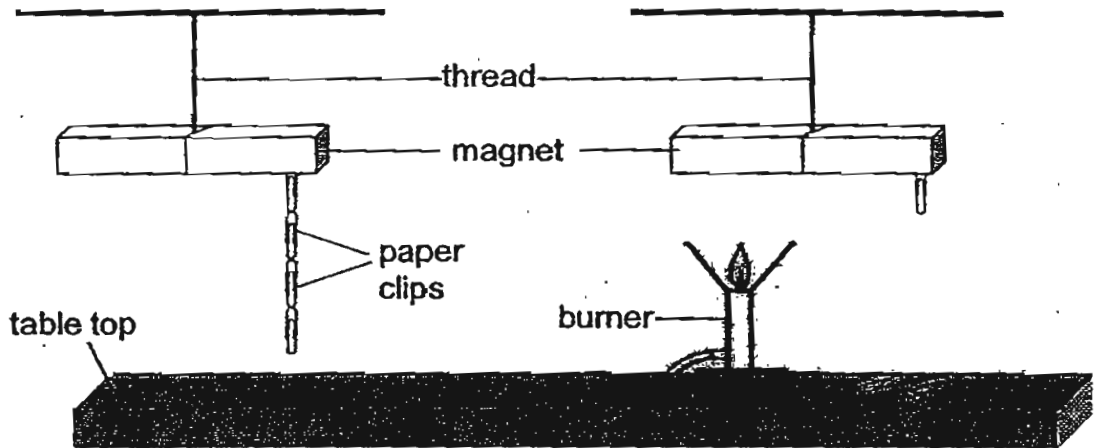

Which of the following explained why the three paper clips dropped from the magnet?

- A The heat caused the magnet to lose its magnetism.
  - B The heat caused the paper clip to lose its magnetism.
  - C The heat expanded the magnet, causing the paper clips to drop.
- (1) A only  
(2) B only  
(3) A and C only  
(4) B and C only



13. Yi Hui carried out the following experiment in a dark room. Four different material sheets, W, X, Y and Z, were placed at an equal distance apart from each other.

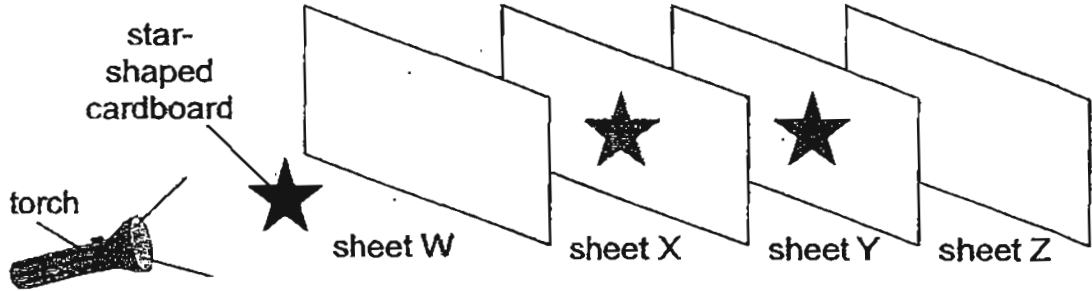

He placed a star-shaped cardboard in front of the torch. A dim image was formed on sheets X and Y. No image was seen on sheets W and Z.

Which one of the following correctly identified the types of materials used by Yi Hui?

	sheet W	sheet X	sheet Y
<del>(1)</del>	Rubber sheet	Coloured plastic sheet	Clear plastic sheet
<del>(2)</del>	Clear plastic sheet	Rubber sheet	Coloured plastic sheet
<del>(3)</del>	Coloured plastic sheet	Clear plastic sheet	Rubber sheet
<del>(4)</del>	Clear plastic sheet	Coloured plastic sheet	Rubber sheet

14. Which one of the following graphs correctly shows the changes in the length of a shadow cast by a lamp post during the day?

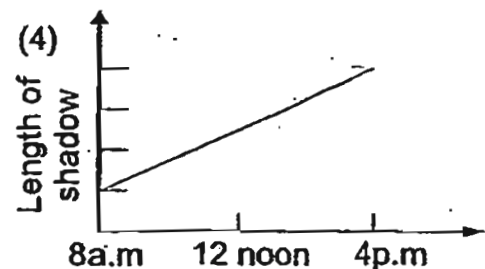
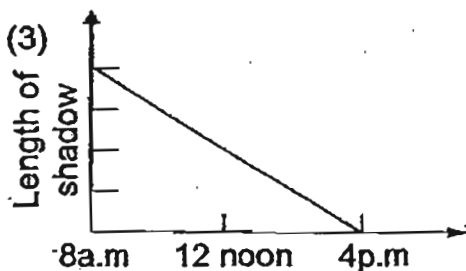
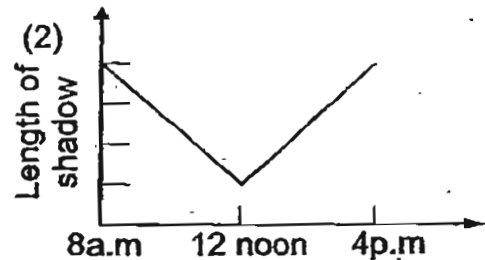
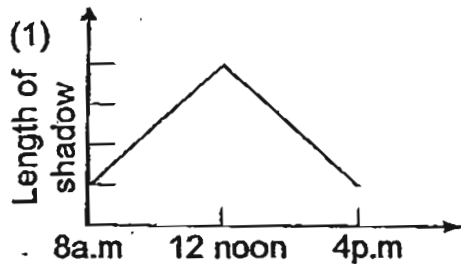

15. Kayden cut out a circle from a sheet of metal and a square from a piece of clear plastic sheet as shown below. The two sheets are of the same size.

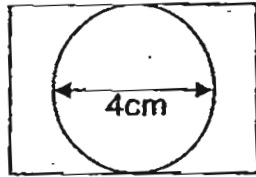

metal sheet

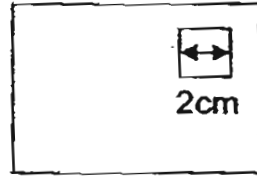

clear plastic sheet

Then the two sheets are glued together and placed between the torch and a screen in a dark room as shown below.

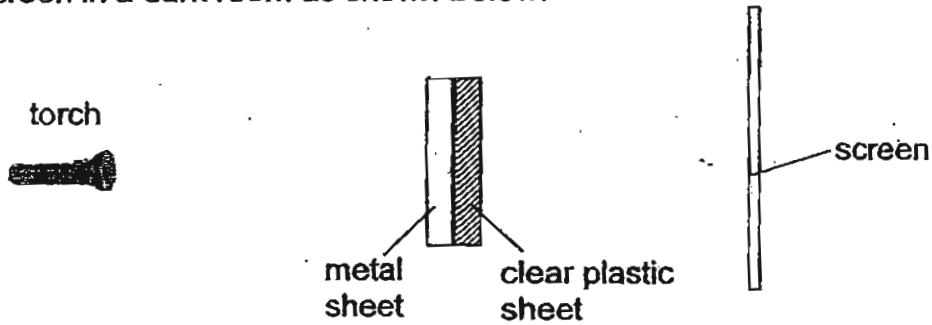

Which one of the following could be the shadow cast on the screen?



16. Madam Lim took out a bottle of milk from the refrigerator and placed it into a cup filled with hot water as shown below.

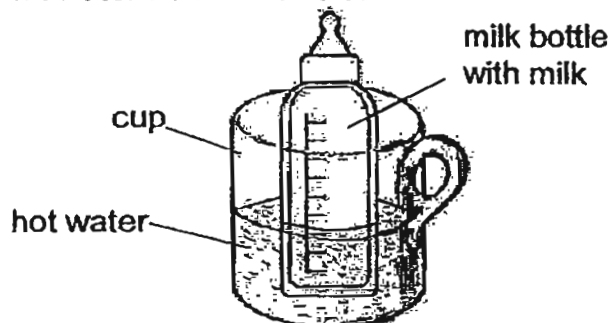

Which one of the following shows the correct heat gain and lost in the set-up above?

	Heat Gain	Heat Lost
<del>(1)</del>	milk	hot water
<del>(2)</del>	milk bottle	milk
<del>(3)</del>	hot water	milk
<del>(4)</del>	milk bottle	cup

17. Jane wrapped a bottle of cold juice with several layers of cloth. After an hour, the cloth was removed and the juice was still cold. Which of the following are possible reasons why the juice was still cold after an hour?

- A The cloth was a poor conductor of heat.
- B The juice lost heat slowly to the surrounding.
- C The juice was not directly exposed to the surrounding.
- D The cloth trapped many layers of air, preventing heat from the surroundings from reaching the juice.

- (1) A and B only
- (2) B and D only
- (3) A, C, and D only
- (4) A, B, C and D

18. Subra had four containers, A, B, C and D, made of different materials. Each container is heated over a burner for five minutes at the same time. He then poured equal amount of tap water of the same temperature into each container and measured the temperature of the water in the containers after one minute.

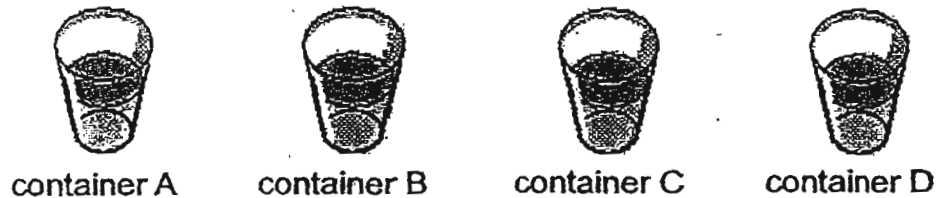

The table below shows the difference between the initial temperature of the tap water and the temperature of the tap water after one minute.

Tap water in container	Difference in temperatures
A	20°C
B	9°C
C	6°C
D	15°C

Which one of the four containers is the poorest heat conductor after it was heated for 5 minutes?

- (1) Container A
  - (2) Container B
  - (3) Container C
  - (4) Container D
19. Sally poured equal amounts of hot coffee into four different cups made of different materials. She recorded the time taken for the coffee in each cup takes to cool down.

Cup	Time taken for coffee to cool (in minutes)
A	10
B	5
C	15
D	20

Which cup is most likely made of metal?

- (1) Cup A
- (2) Cup B
- (3) Cup C
- (4) Cup D

20. Jane filled 2 beakers, P and Q, with 300ml and 100ml of water respectively. She heated both beakers of water until the water boiled. She continued heating the water.

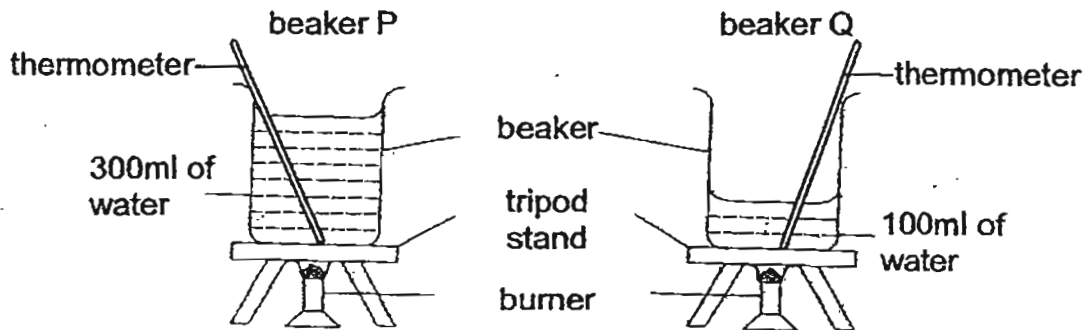

Which of the following statements best describe(s) what she would observe?

- A The water in beaker Q took a shorter time to boil.
  - B The water in beaker Q is hotter than the water in beaker P at the end of the experiment.
  - C The temperature of the water kept on rising throughout the experiment.
- (1) A only  
(2) B only  
(3) A and B only  
(4) B and C only
21. The stem of the plant helps to hold the plant upright. Which one of the following human systems has a similar function of the stem mentioned?
- (1) Skeletal system
  - (2) Digestive system
  - (3) Circulatory system
  - (4) Respiratory system
22. Farid cut off part(s) of a potted plant. He left the potted plant near the window and watered it daily. One week later, the potted plant died. Which part(s) of the plant did Farid cut?
- A Fruits
  - B Roots
  - C Flower
  - D Leaves
- (1) B only  
(2) D only  
(3) A and C only  
(4) B, C and D only

23. Anna and her friends made some comments about the tubes in the stem of a plant.

- Anna : The tubes carry air.
- Bee Leng : The tubes carry food.
- Raju : The tubes carry water.
- Rahim : The tubes carry nutrients.

Who had made an **incorrect** comment?

- (1) Anna only
- (2) Anna and Rahim only
- (3) Bee Leng and Raju only
- (4) Bee Leng, Raju and Rahim

24. The graph below shows the amount of digested food in the blood moving away from different points along the digestive system.

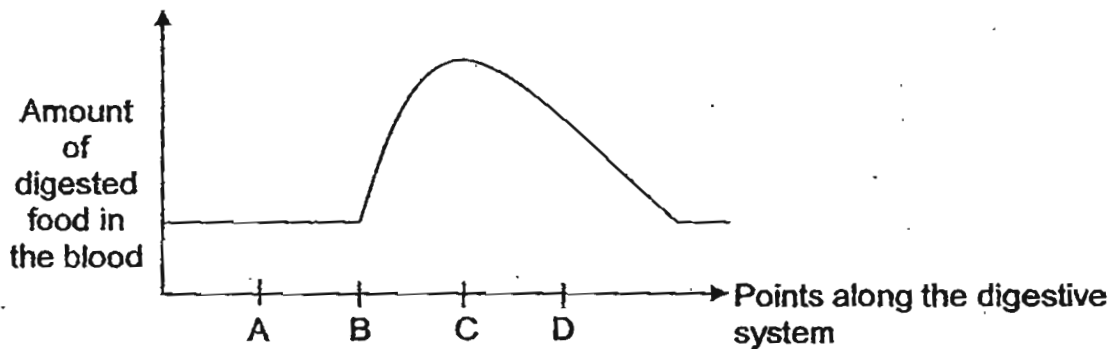

Given that the graph represents the amount of digested food found in the blood, which point(s), A, B, C or D, correspond to the small intestine?

- (1) Point A only
- (2) Point B only
- (3) Points B and C
- (4) Points C and D

25. Study the classification chart below carefully.

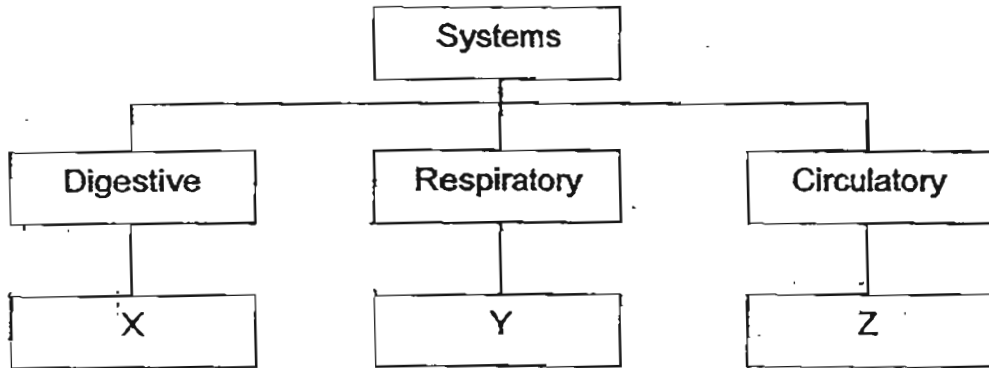

Which one of the following shows the correct body parts in the classification chart?

	X	Y	Z
(1)	Blood vessels	Brain	Large Intestine
(2)	Large Intestine	Heart	Blood vessels
(3)	Stomach	Large Intestine	Blood vessels
(4)	Gullet	Windpipe	Heart

26. The diagram below shows some organs in the human body.

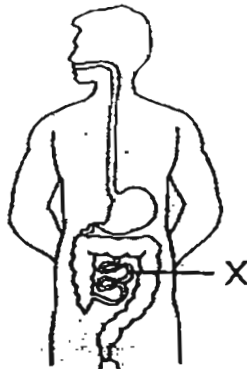

Which of the following statements about organ X is/are false?

- A. All the water in the digested food is absorbed here.
- B. Digested food is absorbed into the blood stream here.
- C. Solid wastes are stored here before passing out of the body.

- (1) A only
- (2) A and C only
- (3) B and C only
- (4) A, B and C

27. Which of the following is/are single-celled organisms?

- A ~~Moses~~ Moss
- B Onion
- C Yeast
- D Paramecium

- (1) D only
- (2) A and B only
- (3) C and D only
- (4) A, C and D only

28. Which of the following statements is/are false about cells?

- A Cells come in different shapes and sizes.
- B All organisms are made up of many cells.
- C An organ is made up of many different types of cells.
- D Small animals have smaller cells as compared to bigger animals.

- (1) A only
- (2) A and C only
- (3) B and C only
- (4) B, C and D only

29. Steve observes his cheek cells through the microscope. The image he sees is unclear. What should Steve do to obtain a sharper image?

- (1) He should turn the fine focus knob.
- (2) He should turn the *coarse* focus knob.
- (3) He should make the light source brighter.
- (4) He should use an objective lens with higher power.

30. Which of the following is/are the purpose(s) of cell division in organisms with more than one cell?

- A For growth
- B For digestion
- C For tissue repair
- D For respiration

- (1) A only
- (2) A and C only
- (3) B and D only
- (4) B, C and D only

\*\*\* End of Section A\*\*\*



Name: \_\_\_\_\_ ( )

Class: Primary 5 \_\_\_\_\_

## CHIJ ST NICHOLAS GIRLS' SCHOOL



Primary 5

First Continual Assessment – 2011

SCIENCE

BOOKLET B

2<sup>nd</sup> March 2011

Total Time for Booklets A and B: 1 hour 45 minutes

14 questions  
40 marks

Do not open this booklet until you are told to do so.  
Follow all instructions carefully.  
Answer all questions.

This paper consists of 15 printed pages.

Booklet A	60
Booklet B	40
Total	100

Parent's Signature/Date

**Section B : (40 marks)**

**For question 31 – 44, write your answers in this booklet.**

**The number of marks available is shown in bracket [ ] at the end of each question or question part.**

31. Study the classification chart below.

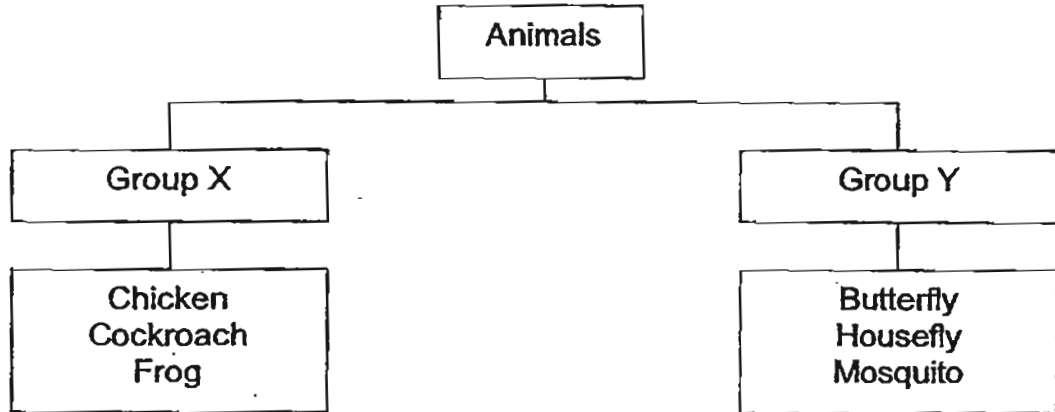

(a) Suggest an appropriate heading for Group X and Group Y respectively. [1]

Group X: \_\_\_\_\_

Group Y: \_\_\_\_\_

Gary found a nymph of an insect and decided to keep it for a period of time for observation. He noticed that it moulted several times before becoming an adult.

(b) How many stages are there likely to be in the life cycle of the insect that Gary was studying? [1]

\_\_\_\_\_

\_\_\_\_\_

(c) Why did the nymph moult? [1]

\_\_\_\_\_

\_\_\_\_\_

\_\_\_\_\_

32. Gresham wanted to investigate the effect of heat on the metal rod.

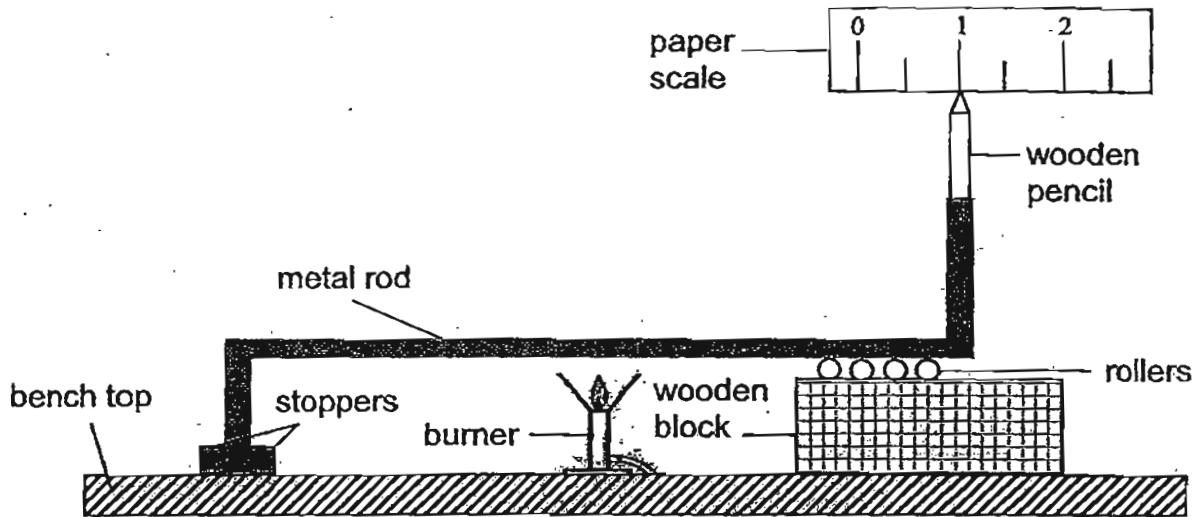

He bent a piece of metal rod to form a shape as shown above. He secured one end of the metal to the bench top. The other end of the metal rod was resting on four rollers that were on a block of wood. A wooden pencil was attached to the top of the metal rod. Gresham then placed a piece of paper scale so that he could measure any movement. A lighted burner was then placed under the metal rod for 5 minutes.

- (a) Which direction, left or right, will the wooden pencil move towards after 5 minutes? Explain your answer. [2]

---



---



---

The diagram below shows the picture of a long bridge.

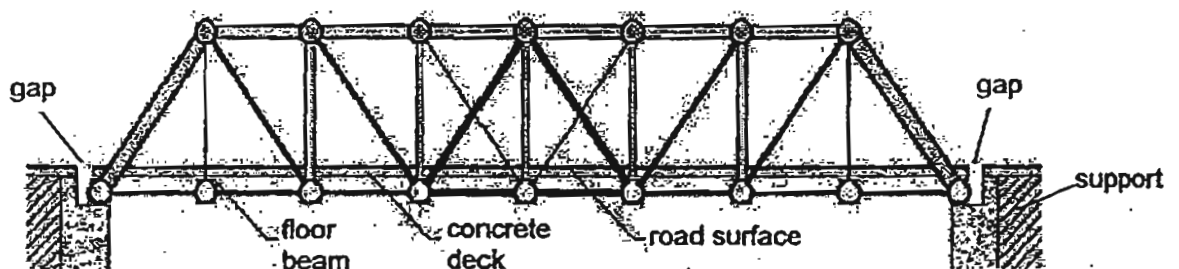

- (b) Why is it necessary for the bridge to have gaps in-between the road surface and the support at both ends of the bridge? [1]

---



---

33. Roger set up the experiment below with an iron rod and a glass rod of the same size. He used two retort stands to secure the rods. He then used some wax to attach four pins, A, B, C and D, at equal distance apart from the burner.

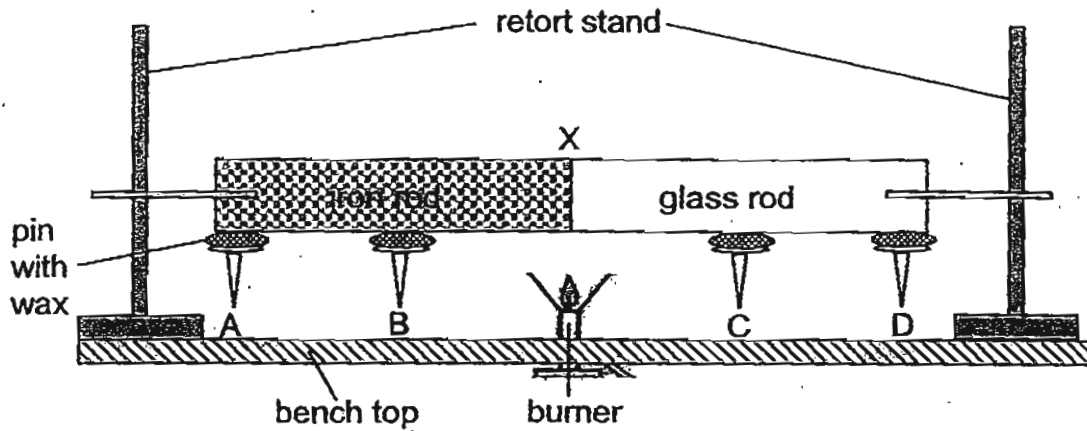

Roger turned on the burner to heat up the rods at the centre marked 'X'.

- (a) Which pin(s) will drop after 10 minutes of heating? Explain your answer. [1]

---



---



---

- (b) Write down the order in which the pins will drop during the heating process. [1]

---

- (c) From the observation of the experiment above, which type of spoon, metal or porcelain, when placed in a cup of hot coffee will help it to cool faster? Explain your answer. [2]

---



---



---

34. Yan Yang put two pieces of plasticine into a transparent measuring cup containing water. She noticed that the water level rose to the 200ml mark.

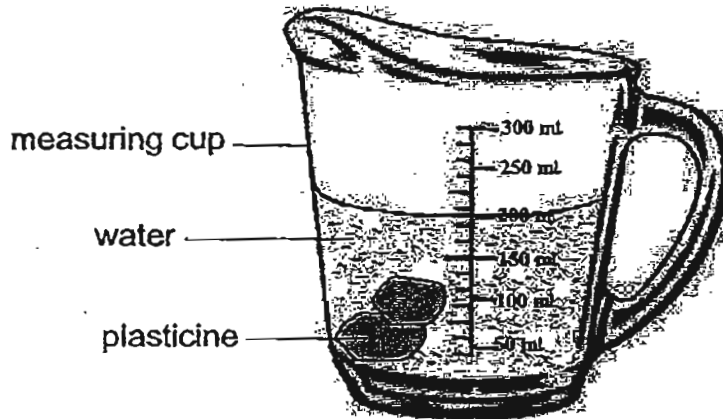

She then took out the plasticine and cut them into smaller pieces and dropped them gently into the water again.

- (a) In the diagram below, draw the new water level of the measuring cup.

[1]

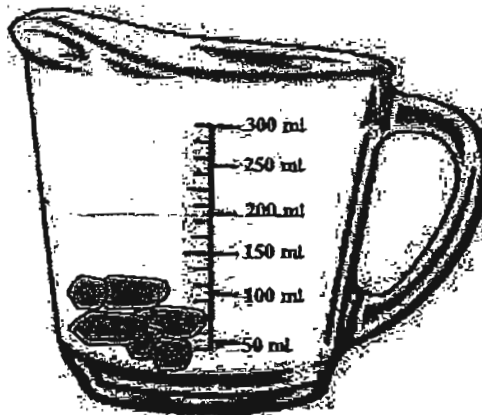

- (b) What is the property/properties of matter that is shown in Yan Yang's experiment?

[1]

---

---



35. Danielle built an electric circuit using some new batteries, wires and an iron rod as shown in the diagram below.

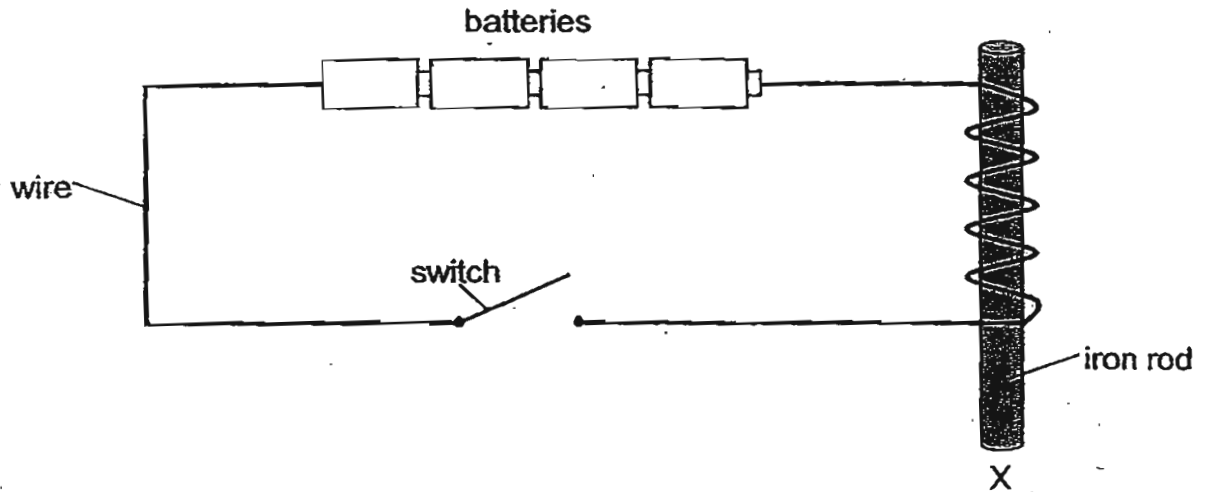

- (a) Danielle placed some small brass nails close to the rod marked 'X' and closed the circuit. What would happen to the nails? Explain your answer. [2]

---

---

- (b) Danielle wanted the iron rod to have a stronger magnetic force. Without adding any additional items to the set-up above, what can she do to enable the iron rod to have a stronger magnetic force? [1]

---

---

Look at the picture below.

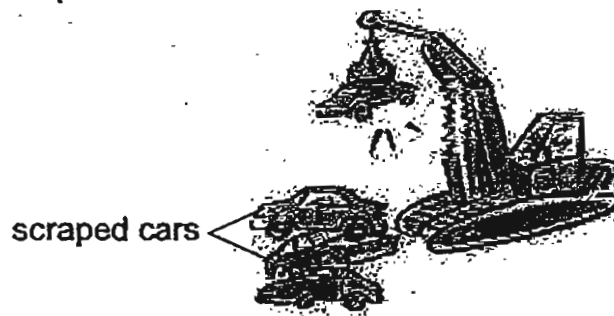

- (c) What kind of magnet is used in a car scrap yard? [1]

---

36. Lynn set up an experiment as shown below.

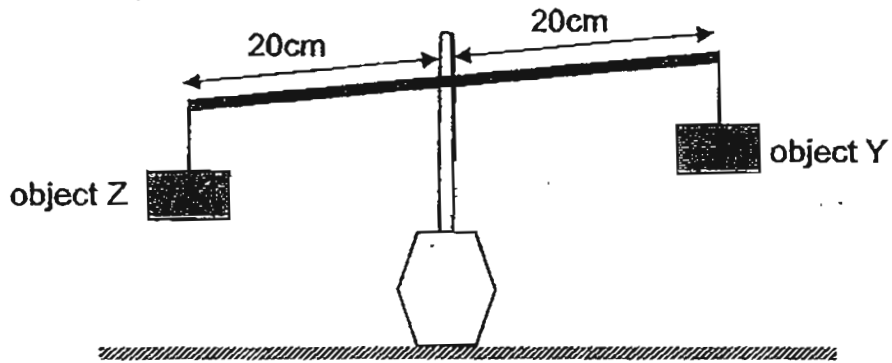

She then placed object A as shown in the diagram below and noticed that the lever was now balanced.

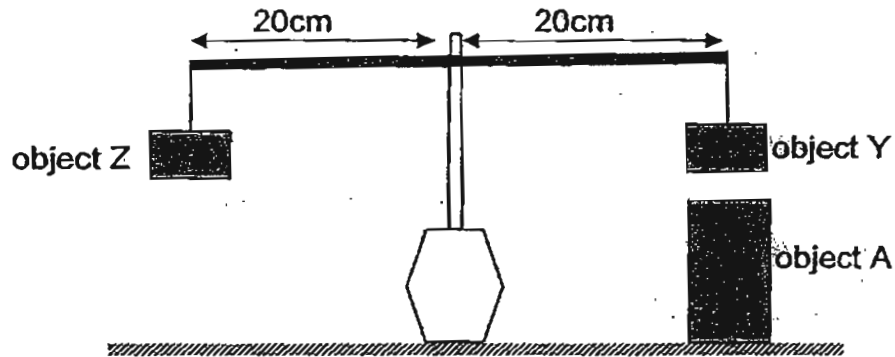

(a) Lynn concluded that object A is a magnet. Is her conclusion correct? Explain your answer. [1]

---

---

(b) When Lynn placed object A under object Z, she observed that nothing happened. What could she conclude about object Z? [1]

---

---



37. Sam had a mixture of some tiny aluminium pieces, iron bits, salt and water in a container. He was given some items as shown in the diagram below.

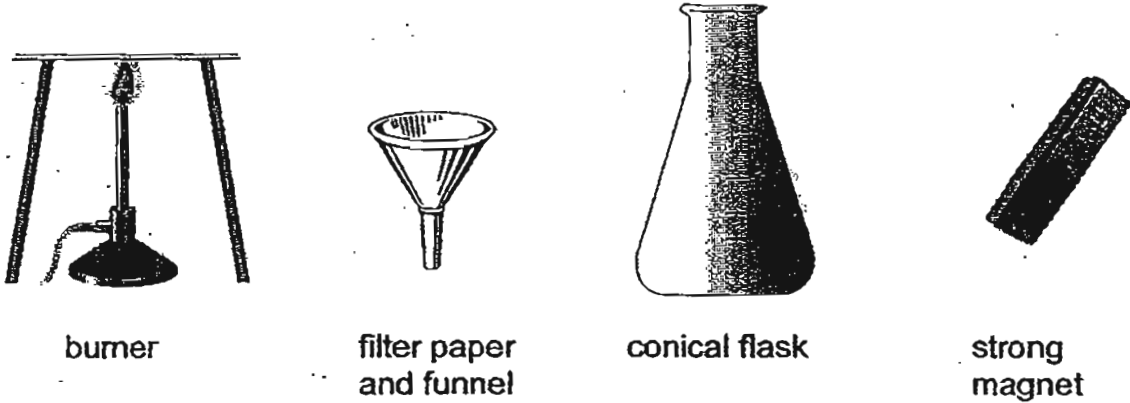

(a) Describe how he could use the given items above to separate the aluminium pieces, iron bits and salt. Write the steps in the table below and indicate what was separated during each step. [3]

Steps	Description	What is separated
Step 1		

(b) If the tiny aluminium pieces were replaced by tiny nickel pieces, would he be able to separate the iron bits and the nickel pieces? Explain your answer. [1]

---



---



38. In a dark room, a torch was shone on a cone from position X and position Y as shown in the set-up below.

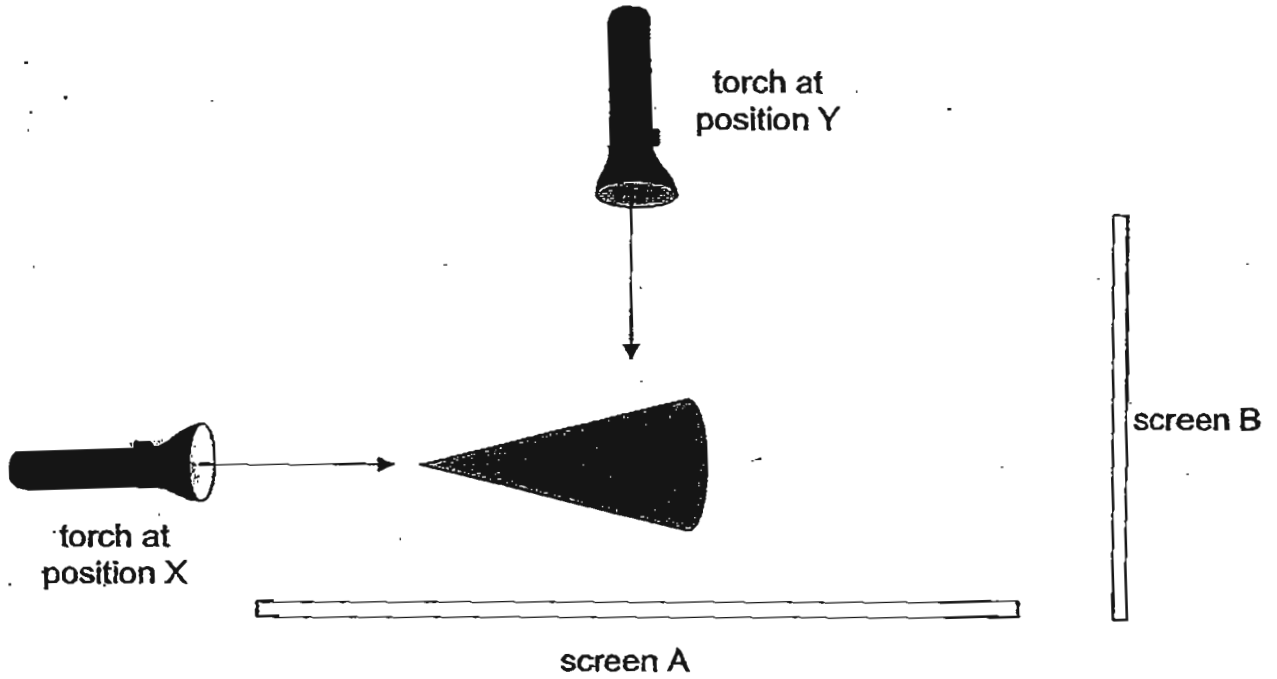

- (a) In the space given below, draw the shadows that were cast on Screen A and B respectively. [2]

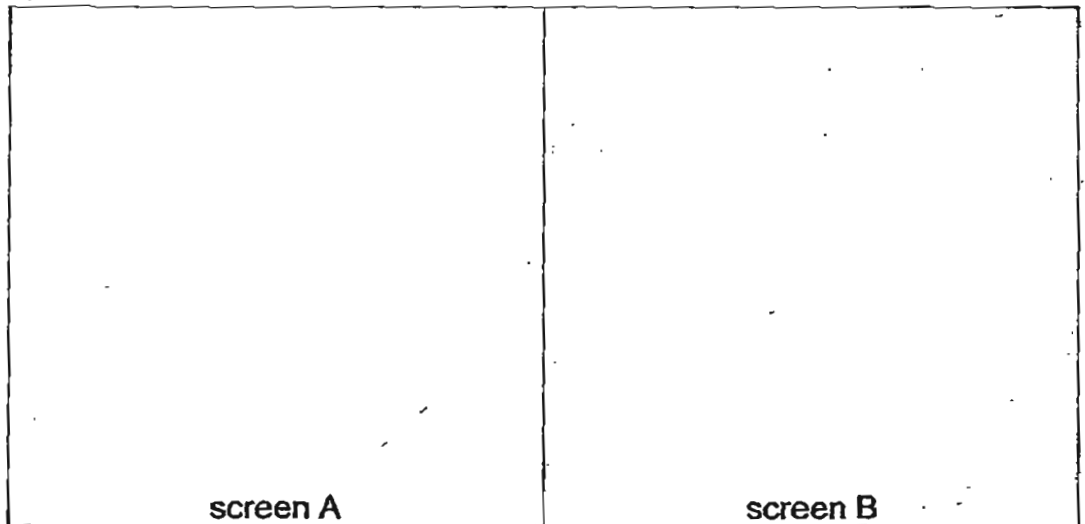

- (b) What should you do to the set-up above if you want to have a smaller shadow cast onto screen A? [1]

---

---

---



40. Jiaman placed a soft toy between a torch and a screen. He moved the soft toy nearer to the torch and recorded the length of the shadow in the table below.

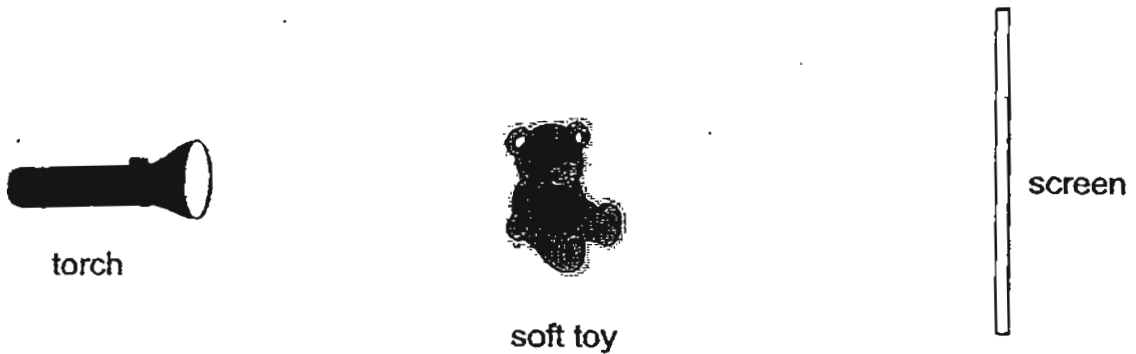

Distance from the soft toy to the torch (cm)	Length of shadow (cm)
30	11
20	17
10	20
5	24

- (a) What is the relationship between the length of the shadow and the distance of the soft toy from the torch? [1]

---



---



---

- (b) Besides the length of the shadow, describe the appearance of the shadow if the distance between the soft toy and the torch decreases. [1]

---



---



---

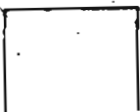

41. Melvin wanted to find out if the boiled water after cooling was suitable for the fish to survive. He took two containers, A and B, and filled them up with tap water. He then boiled the water in container A. After boiling, he covered it with a lid and let it cool down to room temperature. Melvin then placed a fish in each of the container and observed them for two days.

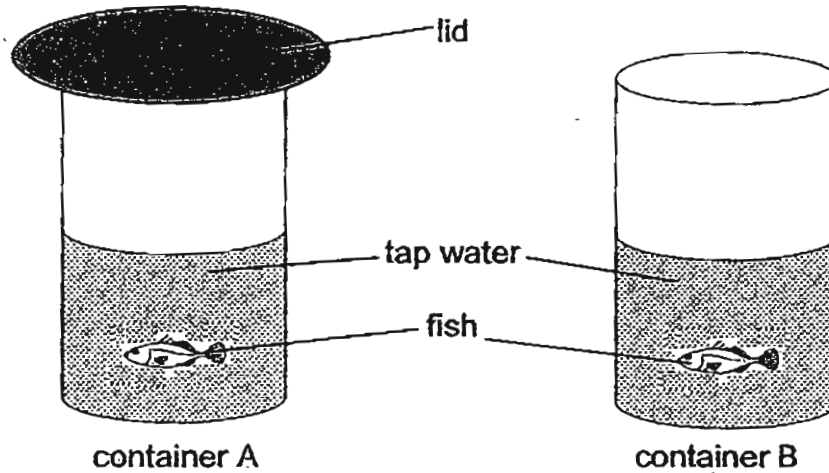

Put a tick in the boxes below to indicate which of the following items should he keep constant for the experiment to be a fair one? [2]

	Constant	Variable
The material of the containers.		
The amount of tap water in each container.		
The size and shape of the container.		
The location where the containers were stored.		

42. Karen observed that when a cell taken from organism X was placed in pure water, it swelled. However, when it was placed in salt solution, it shriveled.

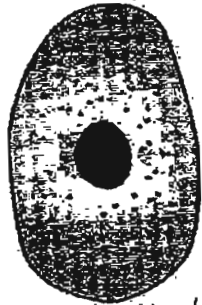

swelled  
cell shriveled  
in pure water



cell shriveled  
in salt solution

- (a) What conclusion can Karen draw about the cell membrane from the above information? [1]

---

---

---

Karen carried out an experiment with a plant cell and an animal cell. She placed both cells in pure water for a few minutes and examined them with a microscope. One of the cells had burst while the other cell became tight and firm but did not burst.

- (b) Which cell did not burst? Explain your answer. [2]

---

---

---

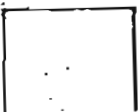

43. Some samples of plant cells were taken from the root hairs of a balsam plant and observed under the microscope.

(a) With the given outline of the root hair cell as shown below, complete the drawing of the parts of the root cell that will be seen under the microscope.

Label clearly all the parts of the cells.

[2]

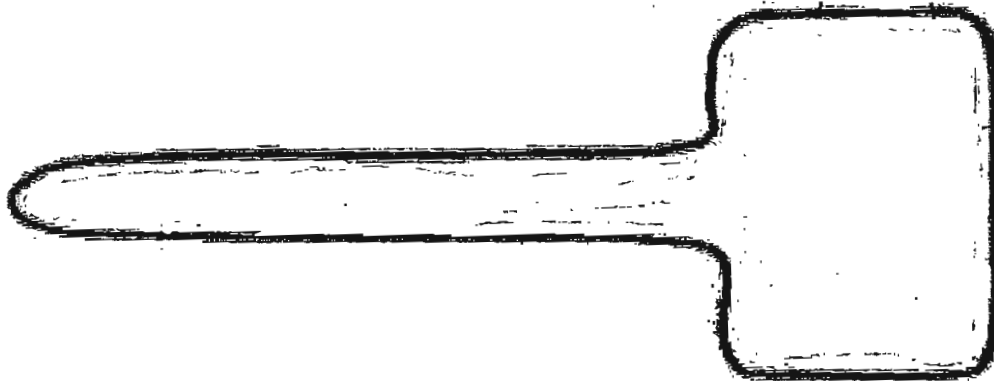

(b) State one physical difference between this root hair cell and a human cheek cell. Do not compare the shape and size of the cell. [1]

---

---

---

44. Read the statements in the table below and write 'T' for true, 'F' for false and 'NP' for not possible to tell in the correct boxes. [2]

	Statement	T / F / NP
(a)	Plant cells have cell wall.	
(b)	When you grow older, your cells will grow bigger.	
(c)	A tissue is made up of cells that are identical to each other.	
(d)	Some cells cannot reproduce to form new cells.	

\*\*\*End of Paper\*\*\*







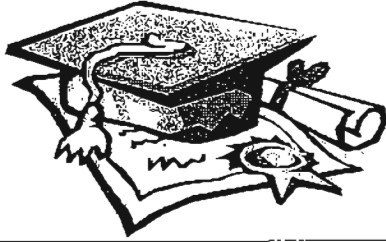

# ANSWER SHEET

**EXAM PAPER 2011**

**SCHOOL : CHIJ  
SUBJECT : PRIMARY 5 SCIENCE**

**TERM : CA1**

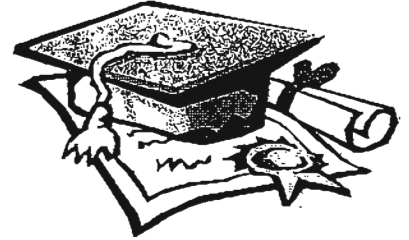

Q1	Q2	Q3	Q4	Q5	Q6	Q7	Q8	Q9	Q10	Q11	Q12	Q13	Q14	Q15	Q16	Q17
4	3	1	2	2	2	3	1	2	1	2	1	4	2	1	1	3

Q18	Q19	Q20	Q21	Q22	Q23	Q24	Q25	Q26	Q27	Q28	Q29	Q30
3	2	1	1	1	1	3	4	2	3	4	1	2

31)a)X: 3-stage life cycle. Y: 4-stage life cycle.

b)There are 3-stges in the life cycle of the insect Gary was studying.

The nymph moulted because it had to shed its skin as it was growing bigger, and its skin was too small.

32)a)The wooden pencil would move towards the right. The heat from the burner causes the metal rod to expand. It is unable to move towards the left as there are two stopped on the left side of the rod. The expanded metal rod then starts to move towards the right and push the rollers towards the right.

b)When it is a sunny day, the road would expand, thus closing the gaps. If there were no gaps, the road will not be able to expand properly, so the road will crack.

33)a)All the pins as heat travels through all things. After 10 minutes the glass part of the rod will get heated up too.

b)B, A, C, D

c)The metal spoon. It would absorb the heat faster as it is a good conductor of heat where the porcelain spoon is a poor conductor of heat, thus it takes a longer time to absorb the heat.

34)a)



b)Solids have definite volume.

35)a)The brass nail would not be attracted to the iron rod. It is not made up of a magnetic material and only magnetic material such as iron, steel, cobalt and nickel can be attracted.

b)Increase the number of coils around the iron rod.

c)An electromagnet.

36)a)Yes, object A is a magnet. Object Y was attracted to the magnet, thus being pulled down.

b)Object Z is made up of a non-magnetic material.

37)a)Step 1: Place the strong magnet above the mixture. / The iron bits from the aluminium pieces and salt.

Step 2: Put the funnel with filter paper on top of the conical flask and pour the mixture through the funnel with filter paper. / aluminium pieces.

Step 3: put the conical flask over the burner to heat up the salt solution. / salt.

b)No. he would not. Nickel and iron are both magnetic material.

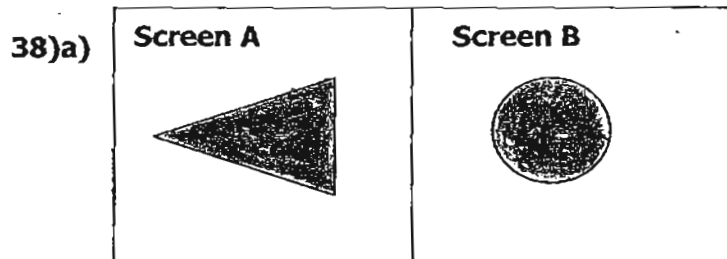

b)Move the torch at position Y higher from the screen.

39)a)

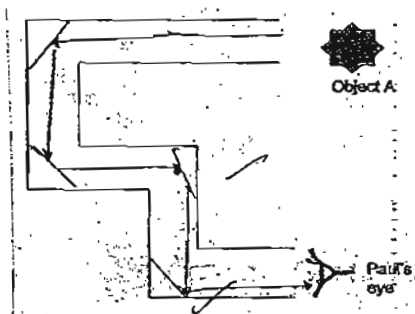

b)No. There is no light reflected off the object to the mirror and to Paul's eyes.

40)a)The further the torch is away from the soft toy, the smaller the shadow gets.  
b)The shadow would be blurrer.

41)Constant  
Constant  
Constant  
Constant

42)a)The cell membrane only allows water to enter or leave the cell.  
b)The plant cell did not burst. The plant cell has cell wall to prevent the cell from bursting.

43)a)

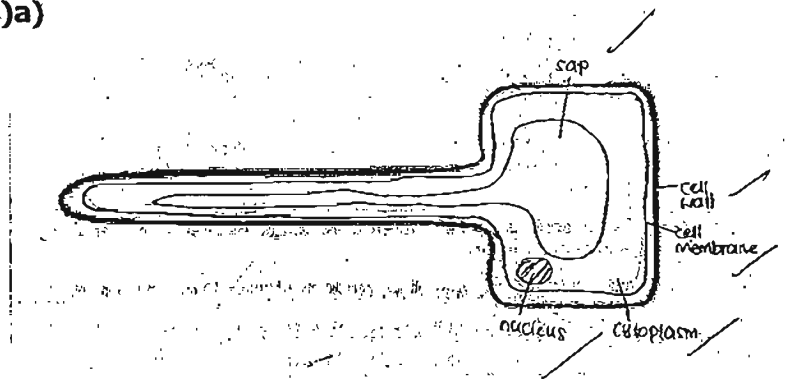

b)The root hair cell has a cell wall whereise a human cheek cell does not.

44)a)T b)F c)T d)T