



HENRY PARK PRIMARY SCHOOL  
2010 SEMESTRAL EXAMINATION 1  
PRIMARY 5 SCIENCE

Booklet A

Name: \_\_\_\_\_ ( )

Class: Primary 5 \_\_\_\_\_

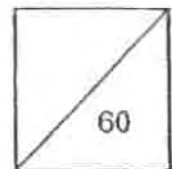

**30 Questions  
60 Marks**

**Total Time for Booklet A and B: 1 h 45 min**

**DO NOT OPEN THIS BOOKLET UNTIL YOU ARE TOLD TO DO SO.**

**READ AND FOLLOW INSTRUCTIONS CAREFULLY.**

**PART 1 (60 marks)**

For each question from 1 to 30, four options are given. One of them is the correct answer. Make your choice (1,2, 3 or 4). Shade the correct oval (1,2,3 or 4) on the Optical Answer Sheet.

1. Which of the following statements are true about properties of water?

- A: It has mass.
- B: It freezes at  $0^{\circ}\text{C}$
- C: It can be compressed.
- D: It evaporates at any temperature.

- (1) A,B and C only
- (2) A,B and D only
- (3) A,C and D only
- (4) A,B,C and D

( )

2. The graph below shows the changes in temperature when a beaker of ice is heated and then cooled in the freezer.

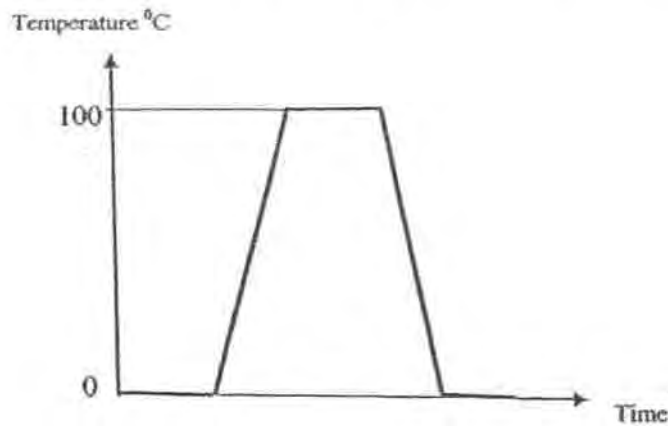

Based on the graph shown, we can conclude that the temperature at which water freezes is the same as the temperature at which

- (1) water boils
- (2) water condenses
- (3) ice condenses
- (4) ice melts

( )



3. After a thunderstorm, Jenny noticed that there were puddles of water on the basketball court. After an hour, there were still some puddles of water on the basketball court. What is the likely cause of the puddles remaining?

A: The surrounding temperature is low  
B: The wind is strong  
C: The exposed surface area of the puddles is greater  
D: The humidity of the surrounding air is high

- (1) A only  
(2) A and D only  
(3) B and C only  
(4) B,C and D only

( )

4. Farmers spray chemicals on their crops to kill pests. When they water their crops in the farm, the water washes the chemicals off into the soil. The chemicals then flow with the water into drains and rivers where fish live.

Which of the following best describes the scenario above ?

- (1) Water recycling  
(2) Water pollution  
(3) Water purification  
(4) Water conservation

( )



5. A beaker containing 200ml of water was heated over a burner.

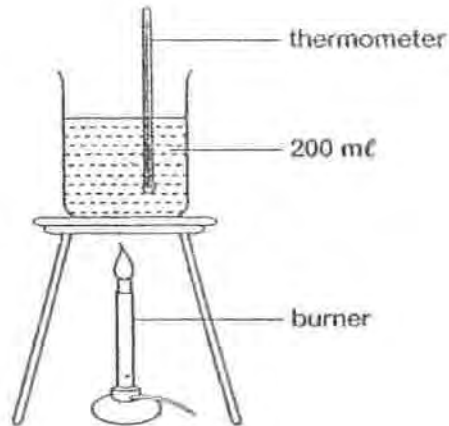

The graph below shows the changes in the amount of water in the container over time.

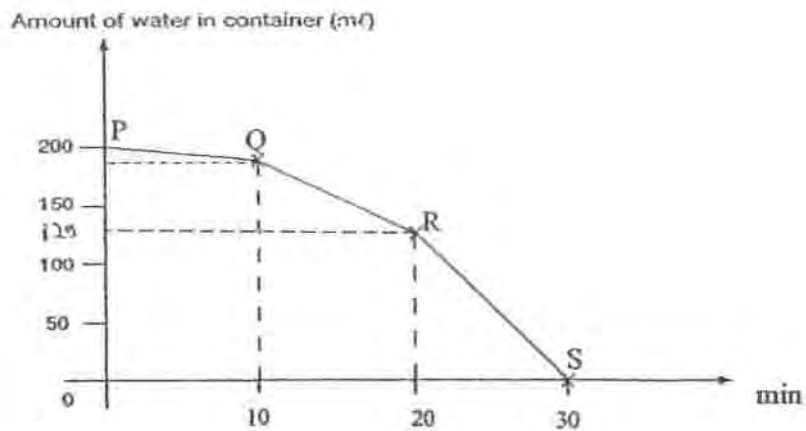

Which of the following statements about the experiment are true?

- A: Water in the beaker starts evaporating from Point Q.
- B: The temperature of water will only reach  $100^{\circ}\text{C}$  at Point S.
- C: Rate of evaporation increases from Point P to Point S
- D: The amount of water lost is the greatest at RS

- (1) A and B only
- (2) A and C only
- (3) C and D only
- (4) A, C and D only

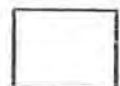

6. In a room, Elaine heated a beaker of tap water for 20 minutes until it started boiling. She continued boiling it for another 10 minutes. Which one of the following graphs correctly shows the changes in temperature of water over the 30 minutes?

(1) Temperature ( $^{\circ}\text{C}$ )

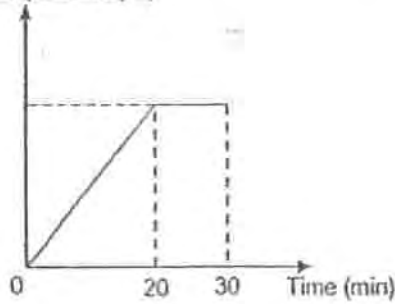

(2) Temperature ( $^{\circ}\text{C}$ )

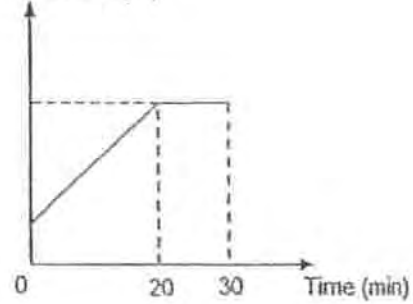

(3) Temperature ( $^{\circ}\text{C}$ )

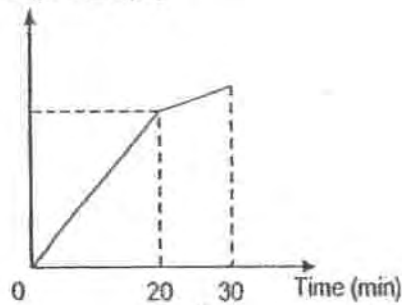

(4) Temperature ( $^{\circ}\text{C}$ )

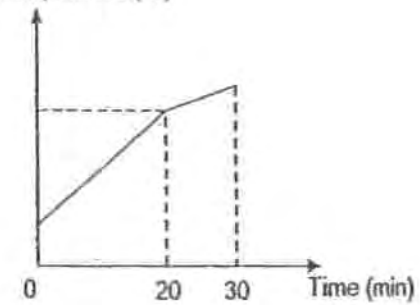

( )

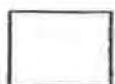

7. Dylan carried out an experiment using set-up A as shown below to find out if the presence of wind affects the rate of evaporation of water. He needed to set up a control for the experiment.

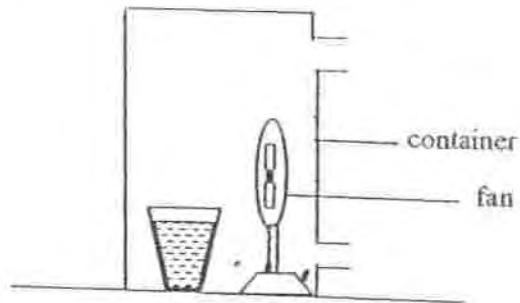

Set up A

Which one of the following should he use as a control?

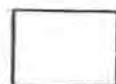
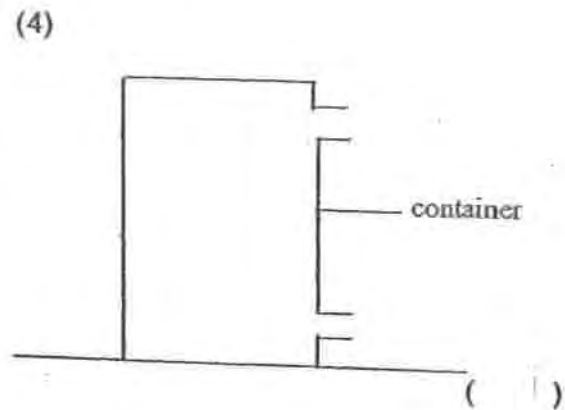
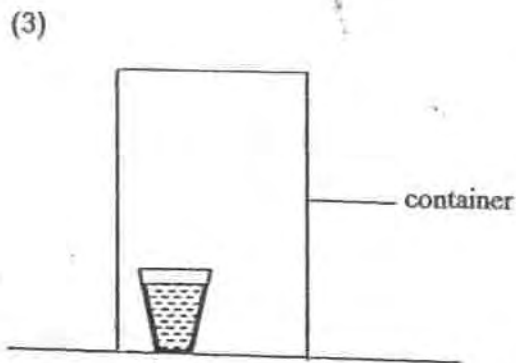
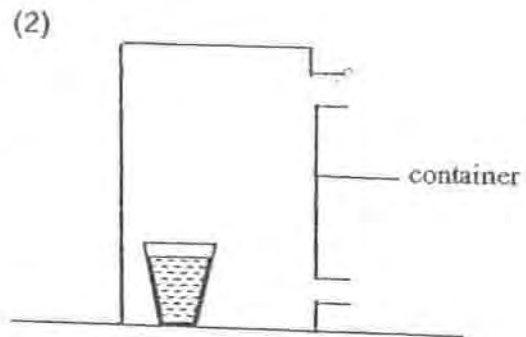
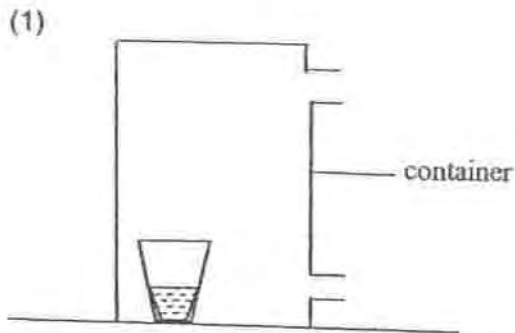

8. Alice has two identical syringes. Each syringe was covered with black paper and completely filled with either air or water.

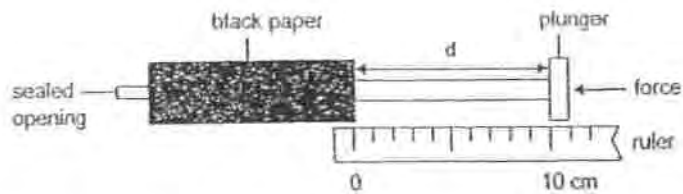

She pushed each plunger as hard as she could. She then measured the distance  $d$ . Which one of the following shows the correct values of  $d$ ?

	$d$ (cm)	
	Syringe with air	Syringe with water
(1)	0	10
(2)	10	0
(3)	6	10
(4)	10	6

9. The diagram below shows water changes states through process A, B, C and D.

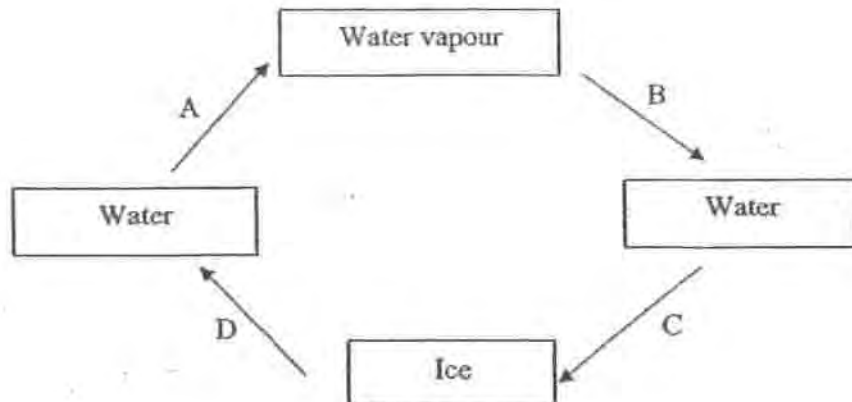

The processes that involves heat gain are

- (1) A and D
- (2) B and C
- (3) B and D
- (4) C and D



10. Study the diagram below.

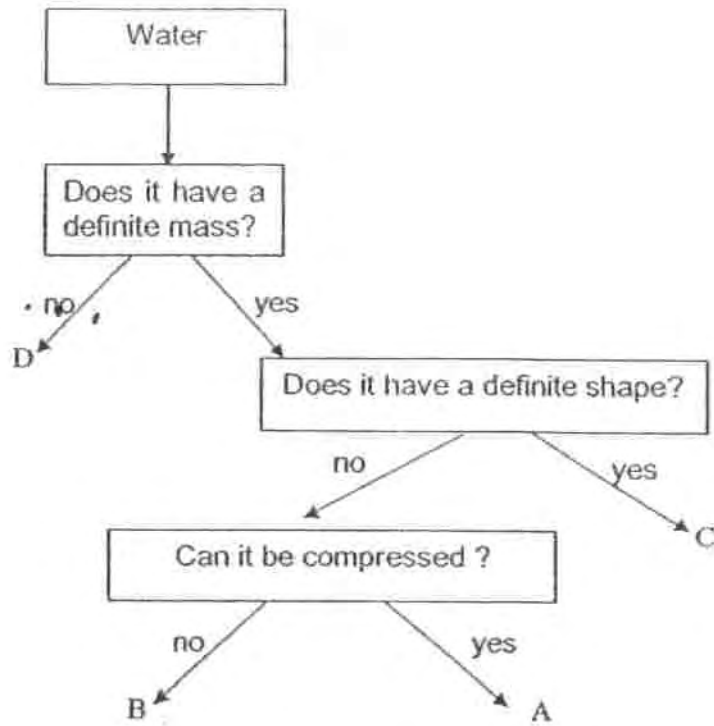

Which of the letters in the diagram represents steam and ice?

	Steam	Ice
(1)	A	C
(2)	B	C
(3)	B	A
(4)	D	B

( )





11. James wants to study the effects of the material of a tray on the rate of condensation of water vapour.

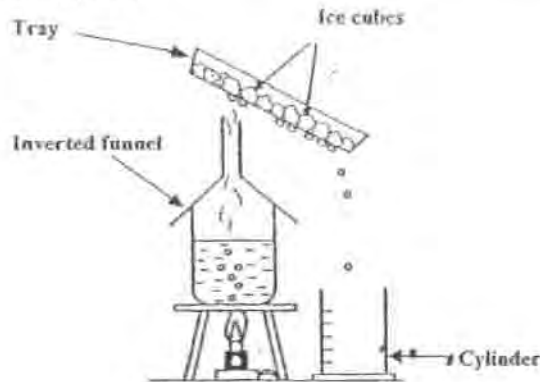

Which of the following set-ups should he use?

(1)

Variable	Tray X	Tray Y	Tray Z
Number of ice cubes on the tray	10 cubes	9 cubes	8 cubes
Material of the tray	Glass	Glass	Glass
Temperature of the surroundings	20 <sup>0</sup> C	20 <sup>0</sup> C	20 <sup>0</sup> C

(2)

Variable	Tray X	Tray Y	Tray Z
Number of ice cubes on the tray	10 cubes	10 cubes	10 cubes
Material of the tray	Glass	Metal	Glass
Temperature of the surroundings	20 <sup>0</sup> C	30 <sup>0</sup> C	40 <sup>0</sup> C

(3)

Variable	Tray X	Tray Y	Tray Z
Number of ice cubes on the tray	10 cubes	9 cubes	8 cubes
Material of the tray	Glass	Metal	Plastic
Temperature of the surroundings	20 <sup>0</sup> C	30 <sup>0</sup> C	20 <sup>0</sup> C

(4)

Variable	Tray X	Tray Y	Tray Z
Number of ice cubes on the tray	10 cubes	10 cubes	10 cubes
Material of the tray	Glass	Metal	Plastic
Temperature of the surroundings	20 <sup>0</sup> C	20 <sup>0</sup> C	20 <sup>0</sup> C

( )



12. The average temperatures of the country for 3 months in 2009 are shown in the graph below.

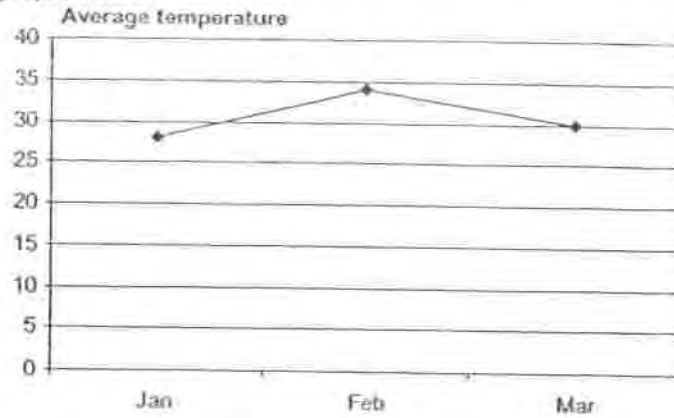

The graphs below show the water consumption of 4 different households for the same period of time.

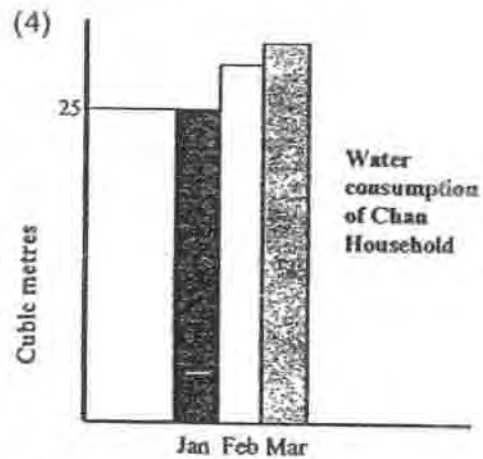
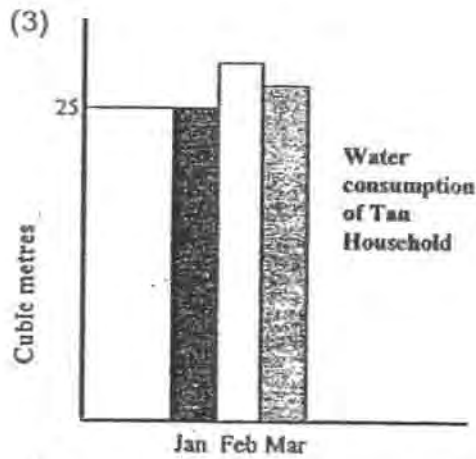
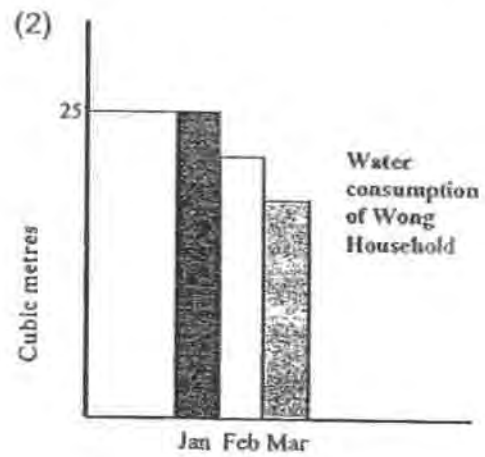
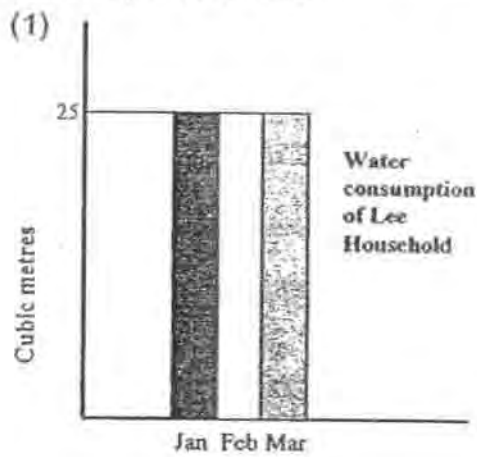

Which household's water consumption is affected by the change in temperature in 2009?

( )



13. A metal lid was used to cover a container of two freshly boiled eggs as shown below.

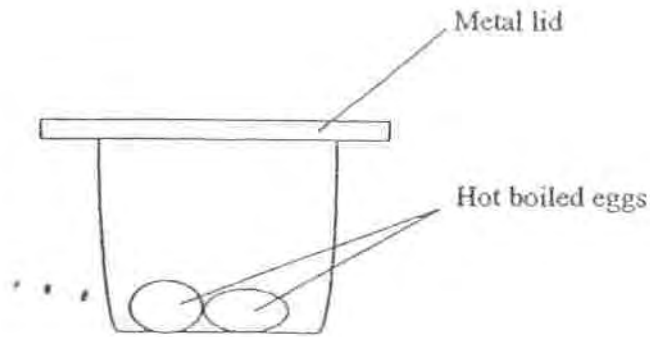

Which set-up below shows what happens 10 minutes later?

(1)

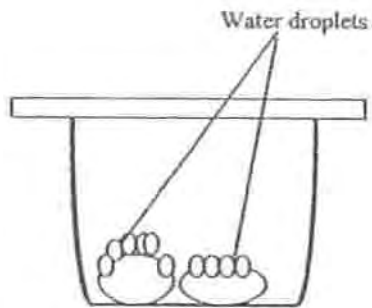

(2)

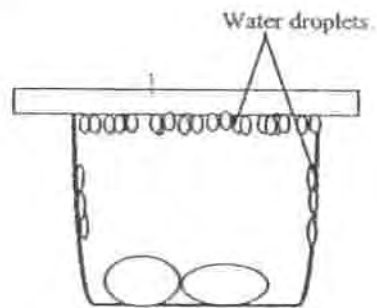

(3)

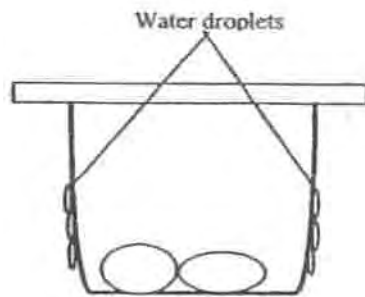

(4)

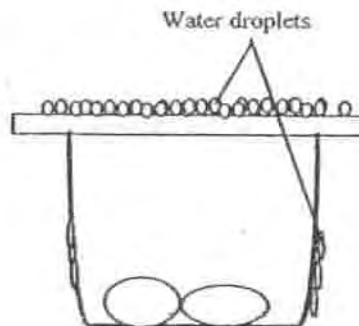

14. Which of the following characteristics is NOT passed from parents to their children?

- (1) Colour of eyes
- (2) Shape of face
- (3) Height of a person
- (4) Length of hair

( )

15. Study Rena's family tree and answer the question below.

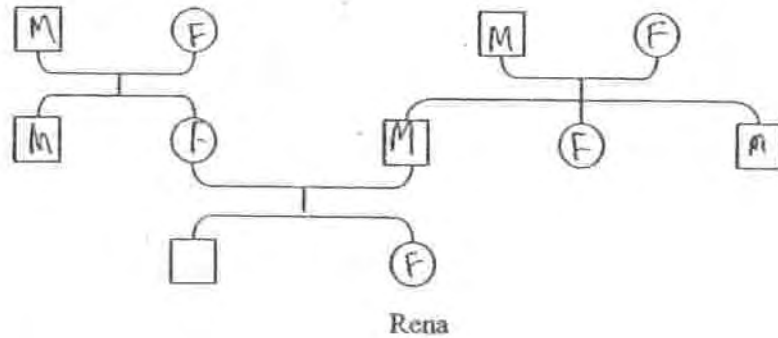

How many uncles does Rena have?

- (1) 1
- (2) 2
- (3) 3
- (4) 5

( )



16. The diagram below show parts of the reproductive organ of a human and a plant respectively.

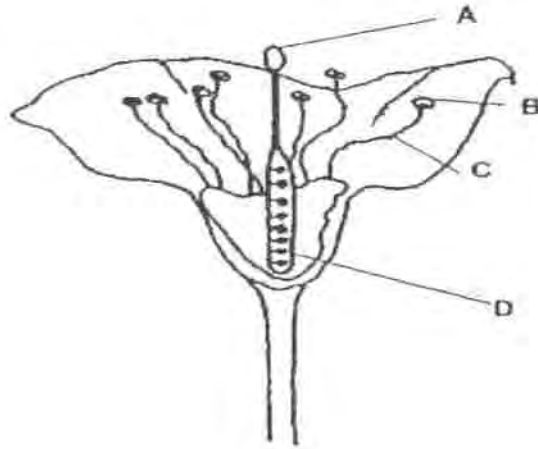
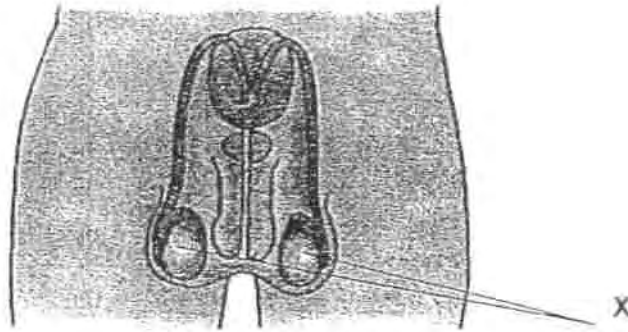

Which part of the flower (A, B, C or D) has a similar function as Part X of the human?

- (1) A
- (2) B
- (3) C
- (4) D

( )



17. Study the chart below.

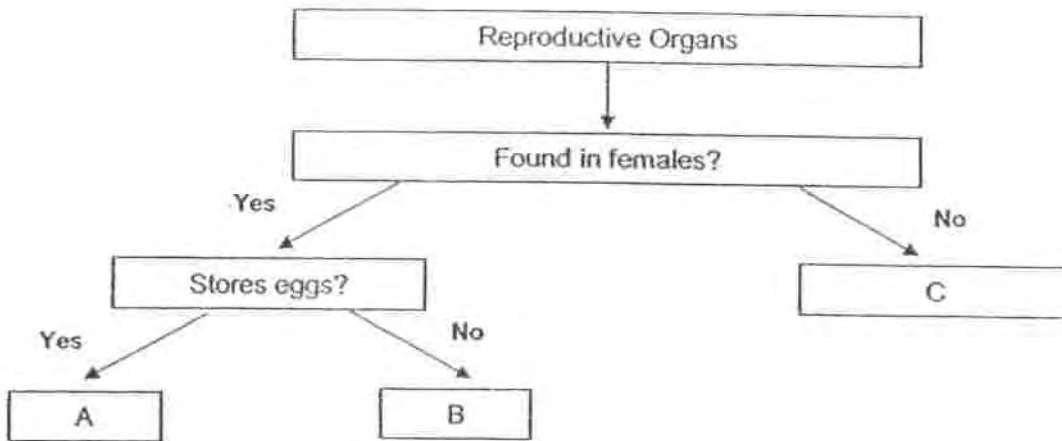

Identify A, B and C of the human reproductive system in the chart below.

	A	B	C
(1)	Ovule	Ovary	Testis
(2)	Ovary	Womb	Testis
(3)	Testis	Womb	Ovary
(4)	Womb	Ovary	Testis



18. Philip wants to investigate the effect of temperature on the growth of seedlings.

γ: Seedling  
Seedling

<p>Dish A at 25°C</p> <p>γ γ γ γ γ γ</p>	<p>Dish B at 25°C</p> <p>γ-γ-γ-γ-γ-γ</p>
<p>Dish C at 30°C</p> <p>γ-γ-γ-γ-γ-γ</p>	<p>Dish D at 30°C</p> <p>γ γ γ      γ γ γ</p>



Which of the two petri dishes should he compare in order to draw a fair conclusion?

- (1) A and B
- (2) A and D
- (3) B and C
- (4) B and D



( )



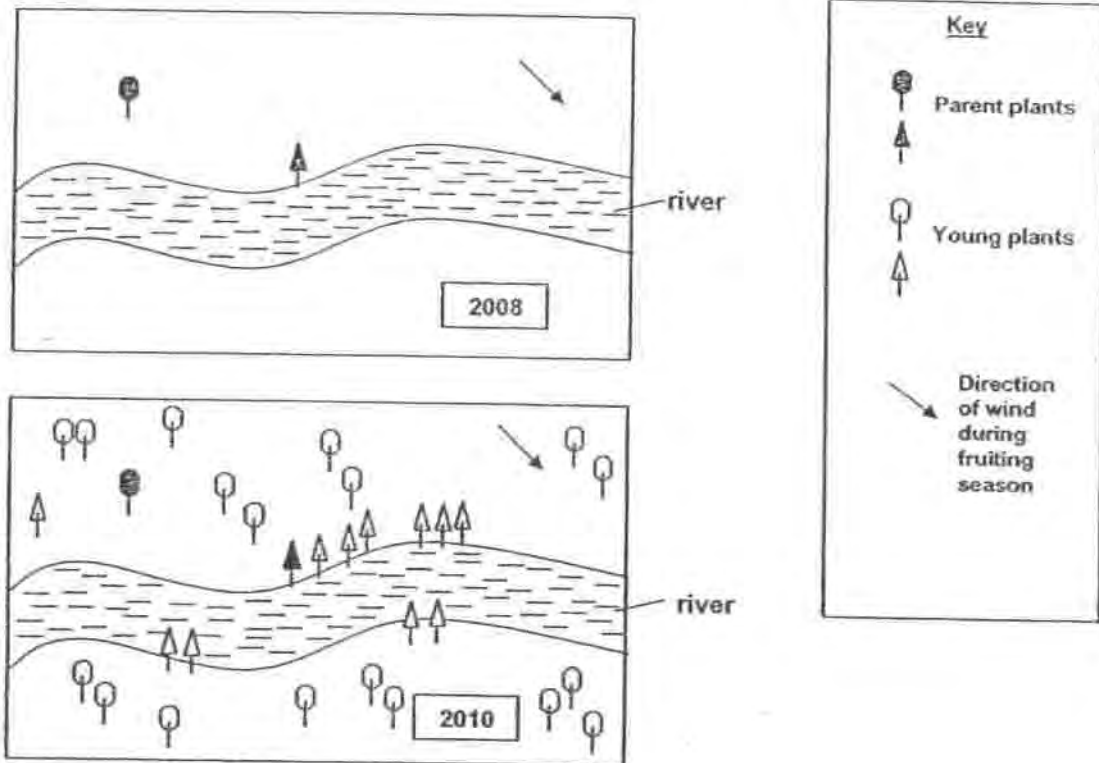

19. Two types of plants are grown on an island.

 and  represent these two types of plants. The following diagrams show changes in plant growth on a part of the island for 2 years.



Which one of the following shows the characteristics of the fruit or seed of the  and  plants correctly?

		
(1)	Has hooks	Has fibrous husk
(2)	Has fibrous husk	Has hooks
(3)	Has wing-like structures	Has fibrous husk
(4)	Has wing-like structures	Splits open





20. Sally plans to conduct an experiment with two flowers that have not been pollinated yet. Both flowers are from the same plant. The following is the procedure of her experiment.

Step 1: Remove Part A from Flower 1, and Parts B and C from Flower 2.  
Step 2: Place the plant in a garden that has similar plants.  
Step 3: Water the plant daily.

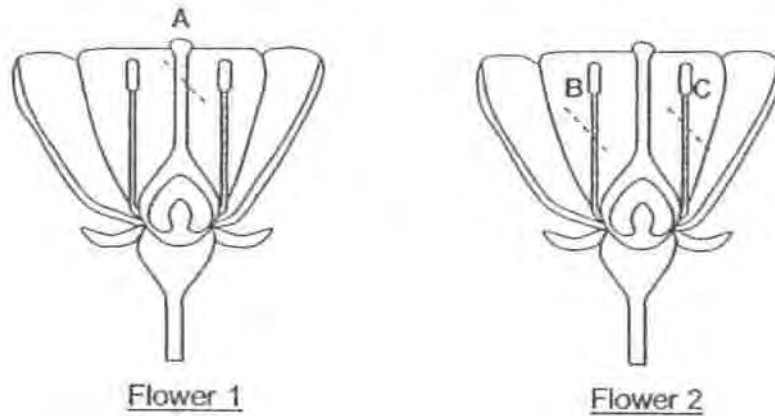

Sally predicts that the following observations will be made after some time. Which of her predictions would most likely be correct?

	Flower 1	Flower 2
(1)	It will develop into a fruit.	It will develop into a fruit.
(2)	It will develop into a fruit.	The flower slowly withered and died. No fruit developed.
(3)	It will slowly wither and die. No fruit will develop.	It will develop into a fruit.
(4)	It will slowly wither and die. No fruit will develop.	It will slowly wither and die. No fruit will develop.



21. The diagrams below show the cross-section of a flower. The black dots in the diagrams represent pollen grains. Which of the following flower(s) has/have just been successfully pollinated?

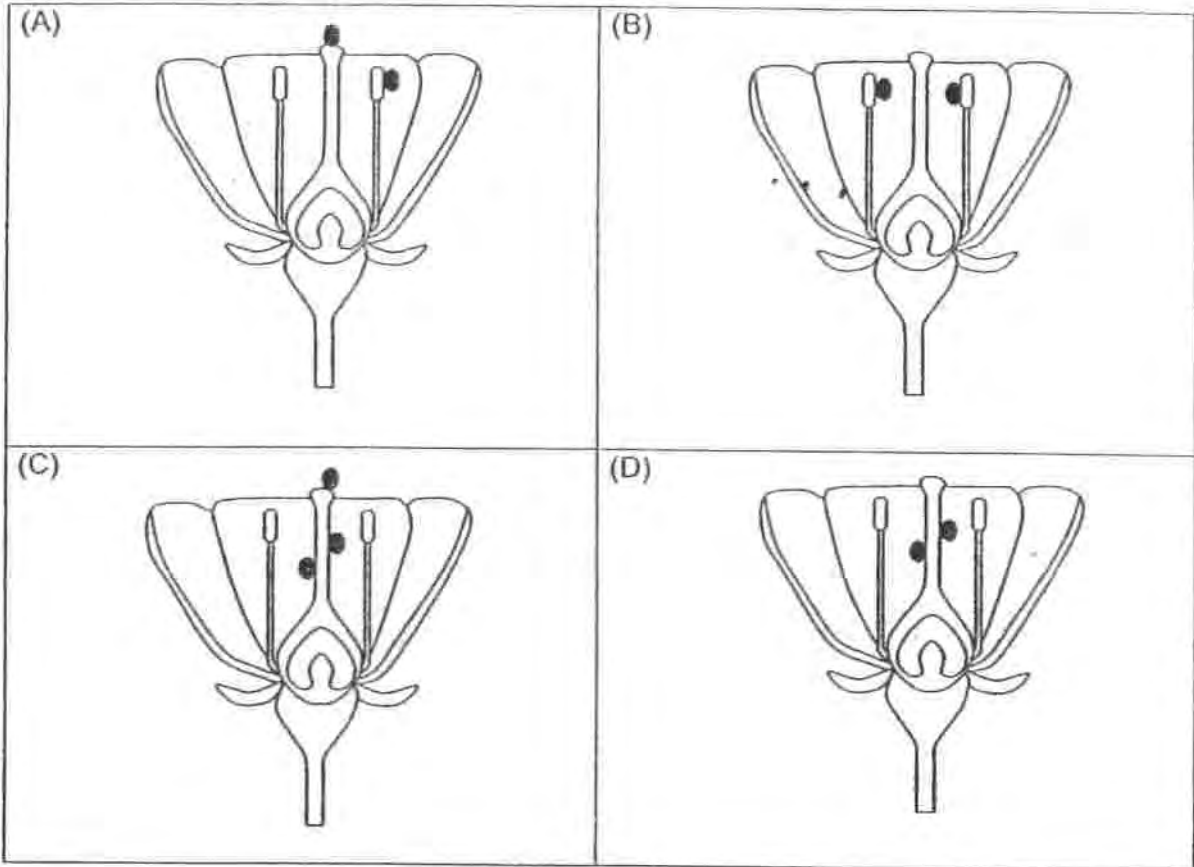

- (1) A only
- (2) C and D only
- (3) A and C only
- (4) A, C and D only

( )



22. Study the diagrams below.



Plant A: Fern



Plant B: Papaya Tree

Which of the following statement(s) is/are true?

- A: Both are flowering plants.
- B: Plant A cannot make food but Plant B can.
- C: The seeds of both plants are dispersed by animals.
- D: Plant A reproduces by spores and Plant B reproduces by seeds.

- (1) B only
- (2) D only
- (3) B and D only
- (4) A and C only

( )

23. The diagram below shows a developing young in the mother's womb.

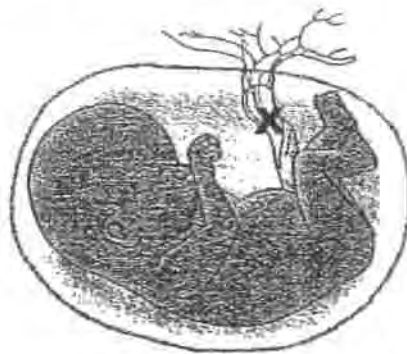

Which statements describe the function of the part labelled X?

- A: It keeps the baby in one position in the mother's womb.
- B: It carries food and oxygen from the mother to the developing baby.
- C: It carries waste matter away from the developing baby.
- D: It produces food for the developing baby.

- (1) A and D only
- (2) A and B only
- (3) B and C only
- (4) A, B and C only

( )



24. The diagram below shows a mango that has been cut length-wise.

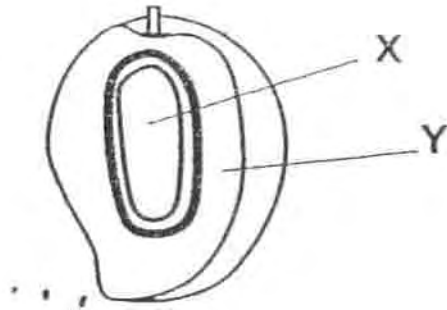

Which part of the flower did Part X and Part Y develop from?

	Part X	Part Y
(1)	stigma	style
(2)	stigma	ovule
(3)	ovule	ovary
(4)	ovary	ovule

( )

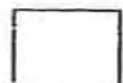

25. Seeds from Plant S were dropped in front of a table fan running at medium speed. The seeds were dropped from the same height, one seed at a time.

After each seed landed on the ground, the distance between the seed and the table fan was measured.

The graph below shows the distance measured for each seed.

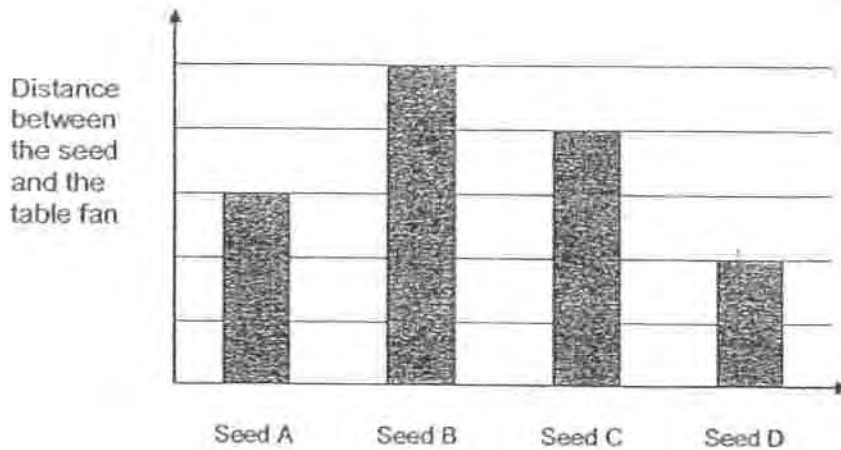

Which of the following statements about the experiment is most likely to be correct?

- (1) Seed D has the smallest mass.
- (2) All the seeds have the same mass.
- (3) Seed B has the smallest mass.
- (4) Seed A has a larger mass than Seed D.



26. Mrs Lee wants to cook an egg with hot water. Which container of water would help her cook the egg in the shortest time?

Egg : 

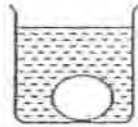

Water at  
70°C

(1)

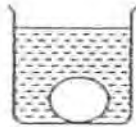

Water at  
90°C

(2)

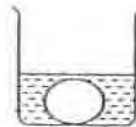

Water at  
70°C

(3)

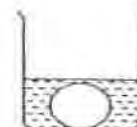

Water at  
90°C

(4)

( )

27. Sam compared the life cycles of the butterfly and the mosquito. He then made the following statements.

Which of the following statements made by Sam are correct?

- A: The young of the butterfly and the mosquito do not resemble their adults.
- B: The young of the butterfly and the mosquito resemble their adults.
- C: Both the butterfly and the mosquito have a three stage life-cycle.
- D: Both the butterfly and the mosquito moult when young.

- (1) A and D only
- (2) A and C only
- (3) B and C and D only
- (4) A , C and D only

( )



26. The table below shows some characteristics of Plants X and Y.

Plants	Bears fruit	Grows in water
X	Yes	No
Y	No	Yes

Based on the characteristics of Plants X and Y, Mary placed them in the classification table below.

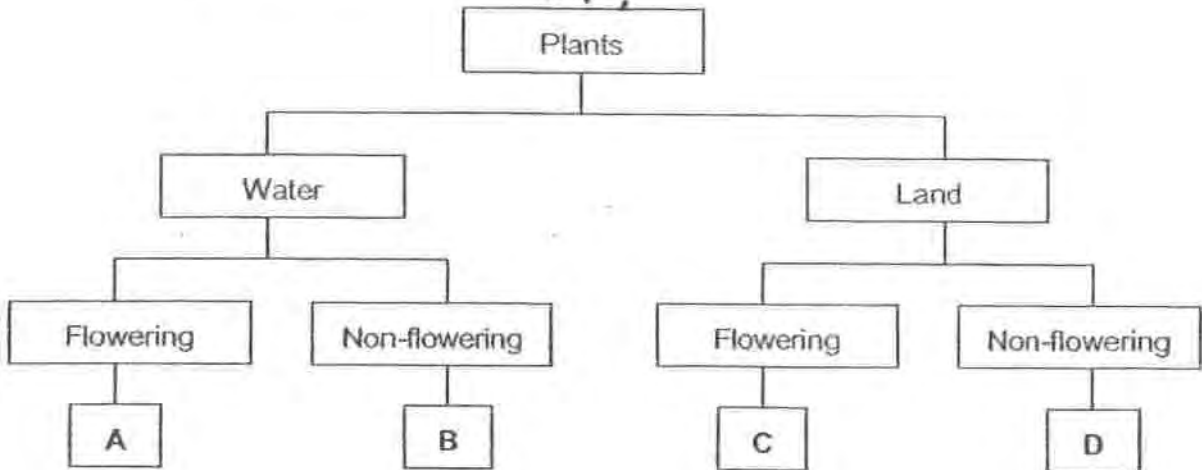

Which one of the following shows where Mary should place Plants X and Y in the classification table?

	Plant X	Plant Y
(1)	A	B
(2)	C	B
(3)	C	D
(4)	D	A



29. Tom pumped  $2000\text{ cm}^3$  of air into the 2 sealed containers as shown below. The capacity of Container A is  $2200\text{ cm}^3$  and the capacity of Container B is  $1800\text{ cm}^3$ .

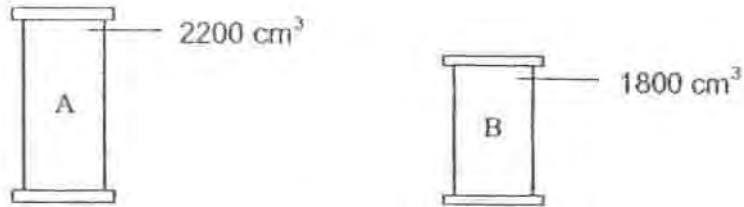

What is the volume of air in each of the containers?

	A	B
(1)	$2200\text{ cm}^3$	$2000\text{ cm}^3$
(2)	$2200\text{ cm}^3$	$1800\text{ cm}^3$
(3)	$2000\text{ cm}^3$	$2000\text{ cm}^3$
(4)	$2000\text{ cm}^3$	$1800\text{ cm}^3$

30. Justin wanted to find out if the amount of water would affect the growth of balsam plants. He planted 3 balsam plants of similar size in three pots A, B and C and watered them daily.

Identify the least important variable that Justin must control in order for his experiment to be fair.

- (1) Material of pots used
- (2) Amount of soil used in each pot
- (3) Volume of water each plant received
- (4) Amount of sunlight each plant received

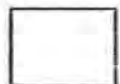





HENRY PARK PRIMARY SCHOOL

2010 SEMESTRAL EXAMINATION 1

PRIMARY 5 SCIENCE

Booklet B

Name: \_\_\_\_\_ ( )

Class: Primary 5 \_\_\_\_\_

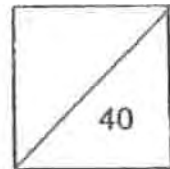

14 Questions  
40 Marks

Total Time for Booklet A and B: 1 h 45 min

DO NOT OPEN THIS BOOKLET UNTIL YOU ARE TOLD TO DO SO.

READ AND FOLLOW INSTRUCTIONS CAREFULLY.

**PART 2 (40 marks)**

Write your answers to questions 31 to 44 in the spaces given.

- 31 Complete the table given below stating the differences between evaporation and boiling of water. The first difference is given. (2m)

Difference	
Evaporation	Boiling
1) Occurs at any temperature	1) Occurs at 100°C
2)	2)
3)	3)



32. Four identical containers A,B,C and D, were filled with the same volume of water. They were left in four places with different conditions for 2 hours as shown in the table below.

Container	A	B	C	D
Conditions	Windy Sunny	No wind Sunny	No wind Cloudy	Windy Cloudy

- a) Complete the bar graph below to show the volume of water left in containers A and C after 2 hours.

(2m)

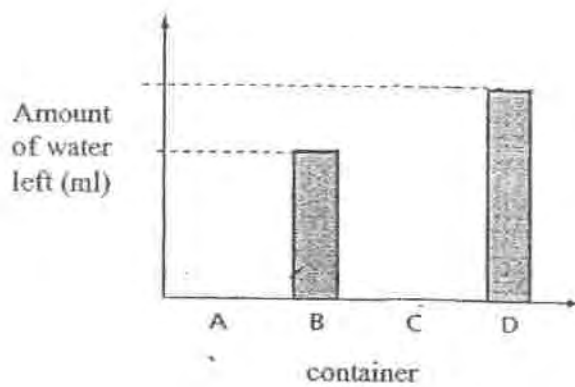

- b) Write down one other variable that must be kept the same in this experiment.

(1m)

---

---



33. Kenny wanted to recycle sea water into clean drinkable water. He designed 2 set-ups as shown below to collect the drinkable water. He began to boil the sea water.

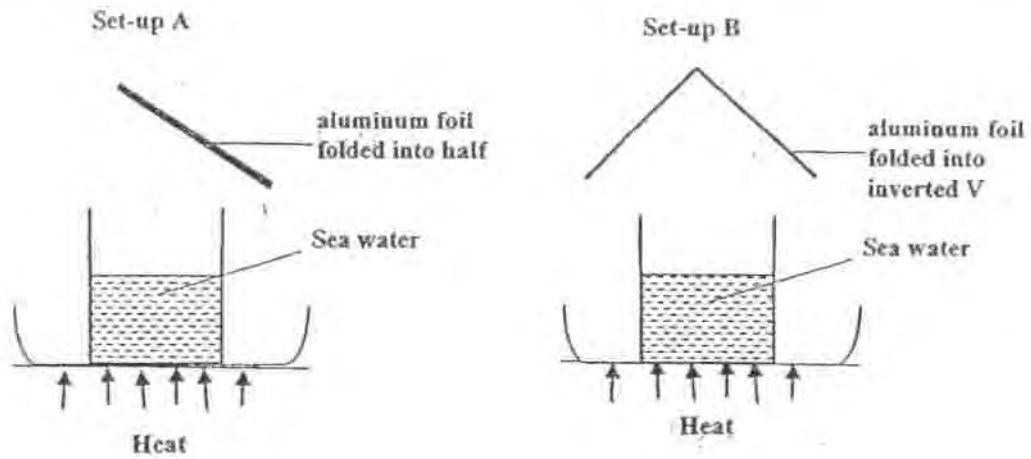

- a) Explain the process by which he could obtain clean drinkable water in both set-ups. (2m)

---

---

---

- b) Which set-up is more effective in collecting the drinkable water? Why? (1m)

---

---

---

- c) Fill in the blanks to show the changes of state of water in your answer above. (1m)



34. Kelvin set up the experiment as shown below. In Set-up A, he filled up the external pot with wet Substance P. In Set-up B, he filled the external pot with Substance Q which can absorb moisture in the air.

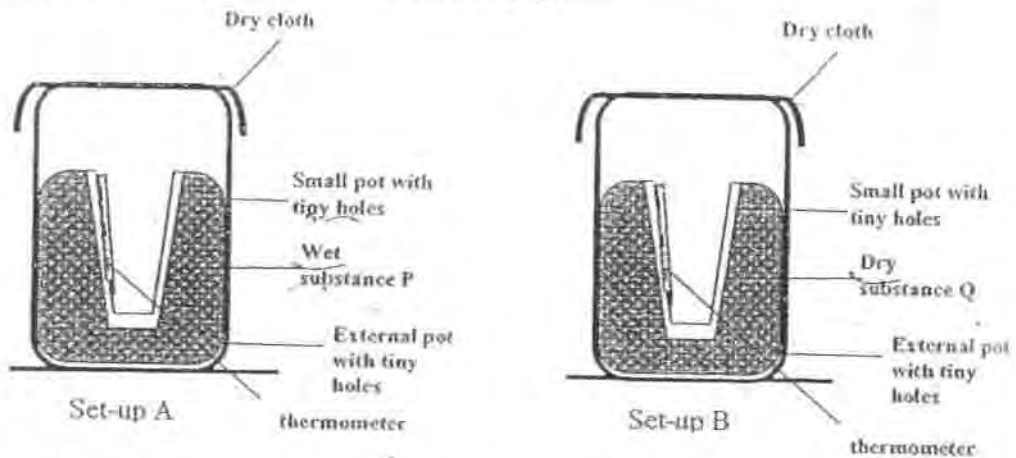

He placed both the set-ups in a dry place and recorded the temperature of air inside the small pots. His results are shown below.

Time (minutes)	Temperature of air in small pot( <sup>o</sup> C)	
	Set-up A	Set-up B
0	30	30
5	28	31
10	27	32

- a) Kelvin observed that the dry cloth in Set-up A became damp. Give an explanation for Kelvin's observation. (1m)

---



---

- b) Explain why is there a drop in temperature inside the small pot in Set-up A but not in Set-up B. (1m)

---



---

- c) A half filled mineral water bottle was left under the sun for a few hours. Make a drawing on the bottle to show what would Kelvin would observe. (1m)

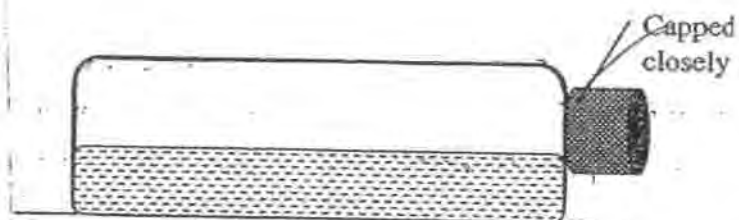

35. Betty wants to find out if the size of the exposed surface area affects the rate of evaporation. The diagram below shows three plastic containers A, B and C that were used to conduct the experiment. Each container contains 500ml of water. The containers were placed near the window for 3 days.

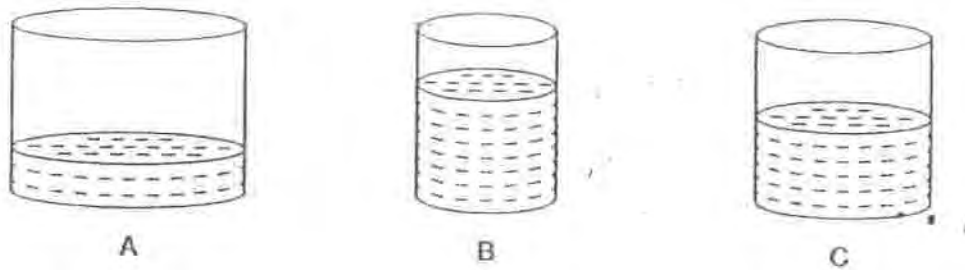

- a) Write a suitable hypothesis for this experiment. (1m)

---

---

---

- b) The graph below shows how the volume of water in the container changed with time.

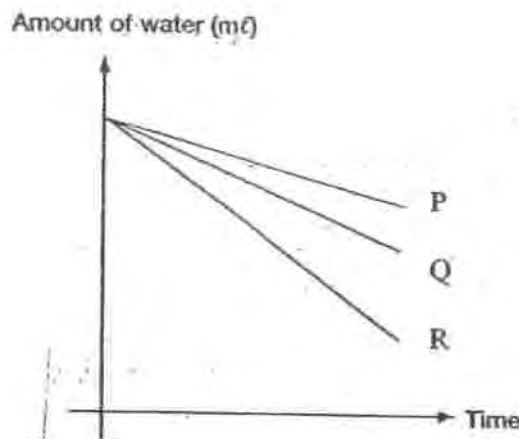

- Which line graph (P, Q and R) would represent the volume of water in container B? Explain why this is so. (2m)

---

---

---

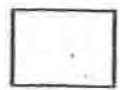

36. The diagram below shows the location of Happy Town. The river is the main source of water for Happy Town. A river flows past Happy Town downstream towards the sea.

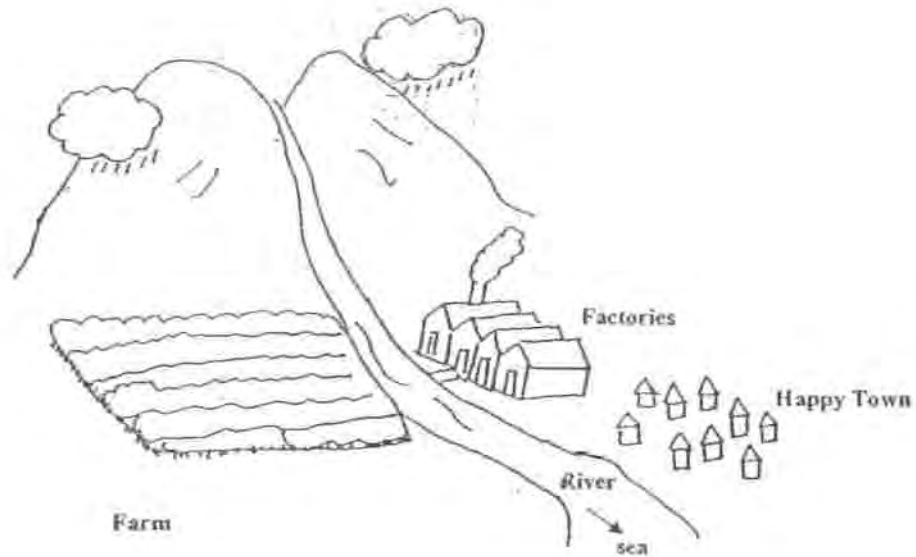

People from Happy Town want to build a water treatment plant which supplies water for home use. The water that is to be treated is pumped to the treatment plant from the point in the river that is nearest to it.

- a) **Indicate** the most suitable position to build the treatment plant by putting an X in the picture above. (1m)

- b) Explain how this location for the water treatment plant ensures clean water for the people of Happy Town. (1m)

---

---

---

- c) If the people want to depend less on the river for water, suggest one thing they can do to obtain more fresh water for daily use. (1m)

---

---



37. The following statement describes a process in the sexual reproduction of humans.

"Sperms are transferred from the male's penis to the female's vagina."

(a) Explain how pollination in flowering plants is similar to this process. (1m)

---

---

---

(b) Complete the table below stating the differences between the reproduction of non-flowering and flowering plants. The first difference is given. (1m)

Difference	
Bird's Nest Fern	Tomato Plant
1) Reproduces by spores	1) Reproduces by seeds
2)	2)





38. The diagram below shows the human female reproductive system.

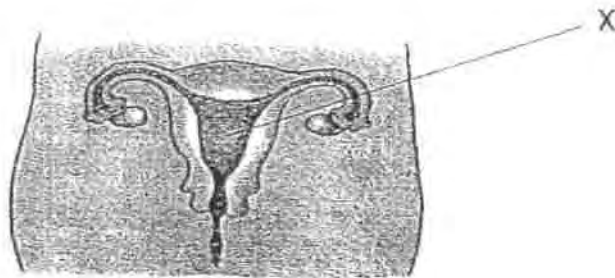

(a) Identify and state the function of X.

(1m)

---

---

---

(b) Susan went to a pet shop. She saw a dog with white fur and brown spots. There were also some puppies on sale. The puppies also had brown spots.

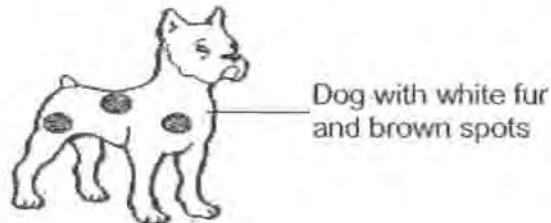

After observing for a while, she made the following statements. Put a tick (✓) in the box if the statement is true.

(1m)

Statement	
The puppies are definitely the offspring of the dog with white fur and brown spots.	
The dog with white fur and brown spots may have parents with white fur.	



39. Mingli observed the cross-section of two flowers, A and B, from different plants.

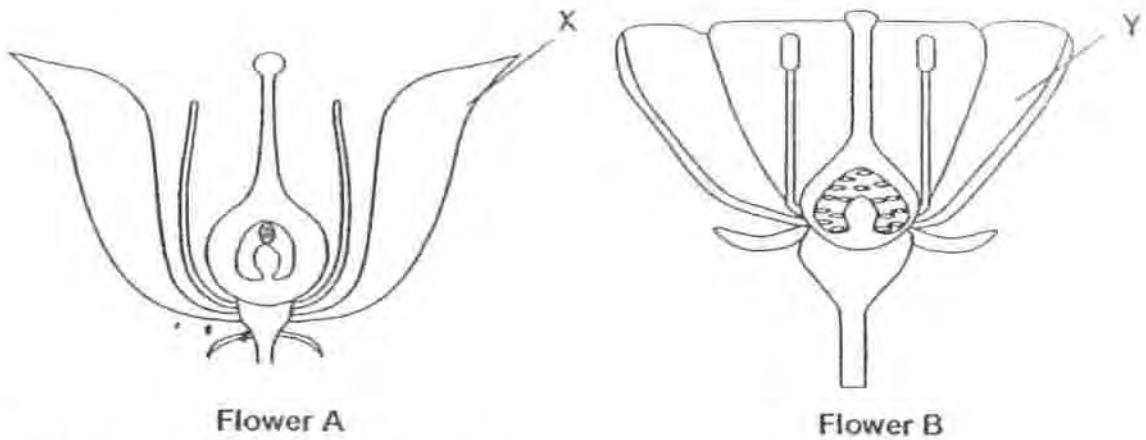

Mingli has a fruit as shown below.

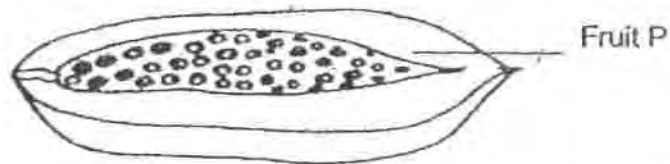

- a) Which flower (A or B) do you think Fruit P is most likely to have developed from? (1m)

---

---

- b) Explain your answer to part (a) above. (1m)

---

---

- c) Describe what will happen to Part X and Part Y after fertilisation has occurred. (1m)

---

---

---



40. Nectaries are parts of a flower that make nectar. Nectar is a sweet substance which insects drink as food.

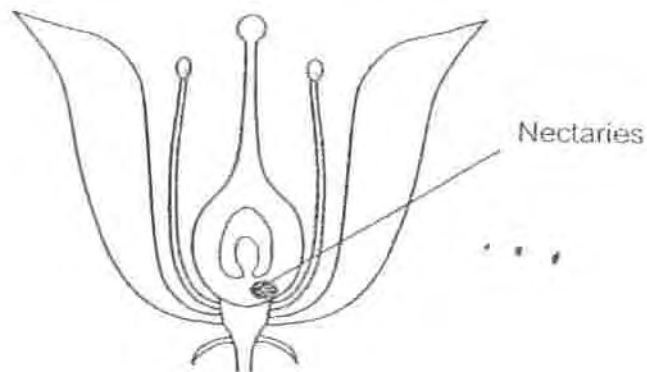

- a) How do you think is Flower A pollinated ? (1m)

---

---

- b) The nectaries are usually located <sup>near</sup> right in the centre of the flower. (2m)  
Explain how the location of the nectaries helps in this type of flower to pollinate.

---

---

---



41. Jane recorded the change in mass of Part X and Part Y of a seed as it was growing into a seedling. The seedling was placed in the garden, under direct sunlight.

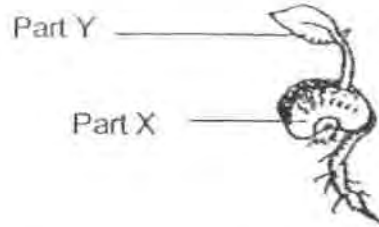

She presented her data in the graph below.

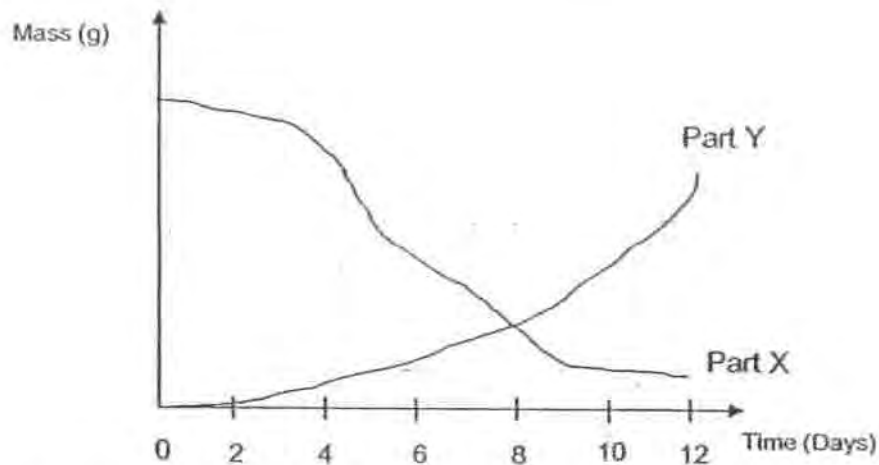

- a) Describe how the mass of Part X changes over time. (1m)

---

---

- b) Describe the relationship between the changes in the mass of Part X and the mass of Part Y as shown in the graph. (1m)

---

---

- c) On the 12<sup>th</sup> day, Jane moved the seedling to a dark cupboard. Predict what will happen to the mass of Part Y 10 days after Jane does that. Explain your answer. (2m)

---

---

---



42 Alvin wants to test the following hypothesis:

When the wing-like structure of the angšana seed is removed, the time taken for the angšana seed to reach the ground will decrease.  
He uses Angšana Seed X to test out his hypothesis.

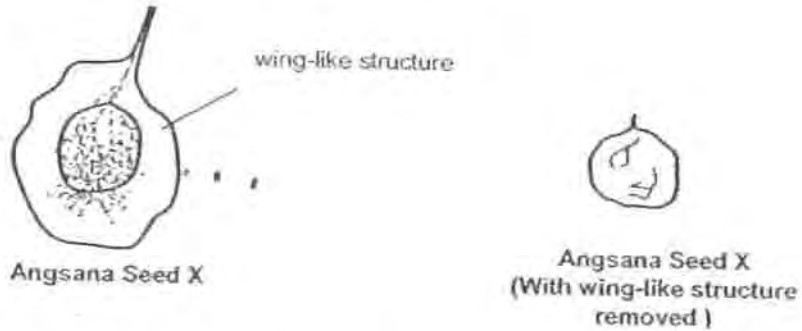

a) Put a tick in the correct column in the table below to select the variables he must keep the same or change to ensure a fair test. (1m)

Variable	Keep the same	Change
(i) Height at which seed is released		
(ii) Strength of wind at the location of the experiment		
(iii) Presence of wing-like structure		



- b) Another boy, Joe, also tests out the same hypothesis using Angsana Seed X. Each boy does the experiment 3 times. They recorded their data in the tables below.

Alvin's Data		
	Angsana Seed X	Angsana Seed X (With wing-like structure removed)
1st Set	8.1 seconds	5.7 seconds
2 <sup>nd</sup> Set	7.9 seconds	5.3 seconds
3 <sup>rd</sup> Set	7.5 seconds	6.1 seconds

Joe's Data		
	Angsana Seed X	Angsana Seed X (With wing-like structure removed)
1st Set	17.3 seconds	15.9 seconds
2 <sup>nd</sup> Set	7.4 seconds	6.3 seconds
3 <sup>rd</sup> Set	7.7 seconds	5.9 seconds

- i) Based on the boys' experiment, describe what happens to the time taken for the seed to fall when the wing-like structure is removed. (1m)

---

---

---

- ii) Compare the data recorded by Alvin and Joe. Whose data would be more reliable? Explain your answer. (1m)

---

---

---



43. Susan had four containers A, B, C and D, each made of a different material. She poured an equal amount of water at 80°C into each container. Next, she measured the time taken for the temperature of the water in each container to reach room temperature of 28°C.

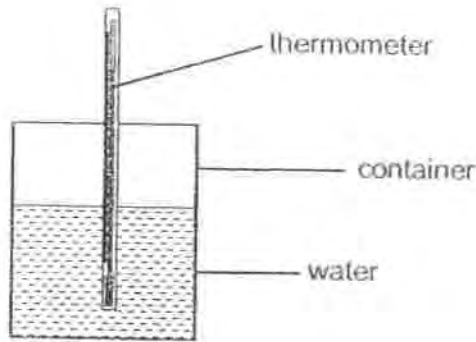

Susan recorded her data in the graph shown below.

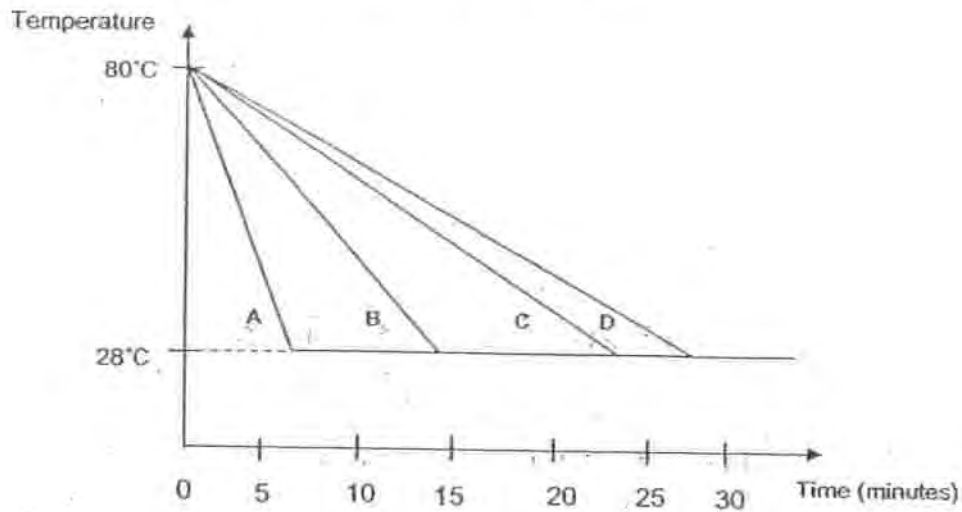

- a) Susan wants to keep a pot of freshly brewed tea hot overnight. Which container should she choose to contain the tea? (1m)

---

- b) Give a reason for your answer. (1m)

---

---

---

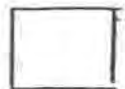

44. Siti carried out an investigation to find out the conditions needed for mould to grow. She placed three pieces of bread in three identical bell jars. The bell jars are airtight (air is unable to enter or escape).

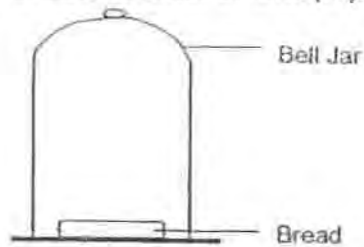

Siti observed the conditions of the bread after every 3 days. She recorded the results as shown in the table below.

Bell Jar	Condition of bread	Observation on Day 3	Observation on Day 6	Observation on Day 9
A	A few drops of water were added to the bread	Slightly mouldy	Very mouldy	Very mouldy
B	The bread was heated in the oven for 5 minutes and cooled before being placed into the bell jar.	Not mouldy	Not mouldy	Slightly mouldy
C	Bread was placed directly into the bell jar.	Not mouldy	Slightly mouldy	Very mouldy

- a) Explain why mould was able to grow on the piece of bread in Bell Jar C although no water was added onto it. (1m)

---

---

---

- b) Why does the piece of bread in Bell Jar B remain mould-free for the longest time? (1m)

---

---

---

- c) Why does mould still grow on the piece of bread in Bell Jar B eventually? (1m)

---

---

---

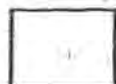





# ANSWER SHEET

**EXAM PAPER 2010**

**SCHOOL : HENRY PARK PRIMARY**  
**SUBJECT : PRIMARY 5 SCIENCE**  
**TERM : SA1**



Q1	Q2	Q3	Q4	Q5	Q6	Q7	Q8	Q9	Q10	Q11	Q12	Q13	Q14	Q15	Q16	Q17
2	4	2	2	3	2	2	3	1	1	4	3	2	4	2	2	2

Q18	Q19	Q20	Q21	Q22	Q23	Q24	Q25	Q26	Q27	Q28	Q29	Q30
3	1	3	3	2	3	3	3	2	1	2	2	1

31)

Difference	
Evaporation	Boiling
1) Occurs at any room temperature	1) Occurs at 100 degrees
2) Occurs at the surface of the water	2) Occurs at any parts of the water
3) Becomes water vapour when it occurs	3) Becomes steam when it occurs

32a)

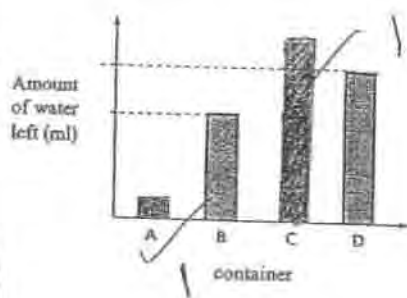

32b) Temperature of water / Type of water

33a) Water is heated and boiled and thus changes to water vapour and upon contact with the cool surface, the water vapour loses heat and condenses.

33b) Set-up B. The aluminum foil has a greater exposed surface/ more space for condensation to collect more water.

33c) Liquid → Gas → Liquid

34a) Water from wet substance P evaporated and condenses on the dry cloth.

34b) When water change to water vapour, it gained heat from the surrounding air.

34c)

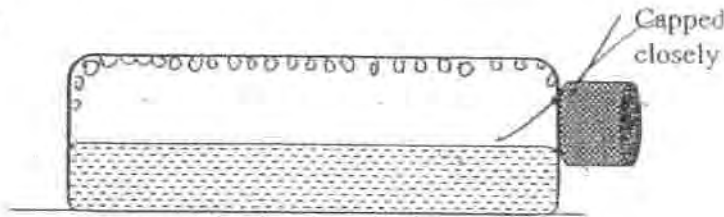

35a) The bigger the size of the exposed surface area, the faster the rate of evaporation.

35b) Line P. Container B had the smallest exposed surface area, and will slow down the rate of evaporation hence, less water evaporated from it and amount of water left would be the most.

36a)

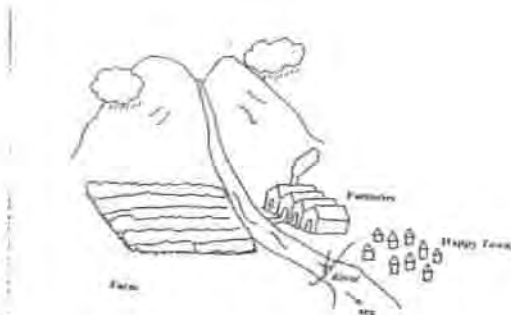

36b) The water treatment plant is needed to remove pollutants flowing from the factories and farm.

36c) Build a reservoir on the hill top to collect water.

37a) Pollen grains from the male anther are transferred to the female stigma.

37b)

Difference	
Bird's nest fern	Tomato Plant
1) Reproduces by spores	1) Reproduces by seeds
2) Does not bear fruits	2) Bears fruits

38a) It is the womb and it keeps the developing embryo.

38b)

Statement	
The puppies are definitely the offspring of the dog with white fur and brown spots.	
The dog with white fur and brown spots may have parents with white fur.	✓

39a) Flower B

39b) Many ovules in the ovary of flower B develops into many seeds in fruits.

39c) It will wither and die.

40a) It is pollinated by insects.

40b) When bees come to collect nectar the pollen grains will stick to the hairy body of the insects and will be brushed onto the stigma when it is leaving.

41a) The mass of Part X will decrease over time.

41b) As the mass of Part X decreases, the mass of Part Y increases.

41c) The mass of Part Y will decrease. The seedling has run out of food source from the seed leaves and there is no sunlight to make food.

42a)

Variable	Keep the same	Change
(i) Height at which seed is released	✓	
(ii) Strength of wind at the location of the experiment	✓	
(iii) Presence of wing-like structure		✓

42bi) The time taken for the seeds to drop will be faster.

END

42bii) Alvin's data. The intervals between the 1<sup>st</sup> Set and the 2<sup>nd</sup> Set was close to each other but Joe's data was not, which means he did not test each seed from the same height.

43a) Container D.

43b) As container D took the longest time to reach 28 degree Celsius, it will take the longest time for the tea to turn cold.

44a) The humidity level in the Bell Jar was high and the moisture allowed mould to grow on the bread.

44b) The piece of bread was heated which mean that moisture in the bread was evaporated and thus with little moisture, it was harder for mould to grow on the bread at first.

44c) It was only heated for five minutes and was left to cool in the Jar and eventually the humidity level will increase and mould will grow.