

Name : _____ ()

Class : Primary 5 _____

CHIJ ST NICHOLAS GIRLS' SCHOOL



Primary 5

Semestral Assessment 1 – 2017

SCIENCE

BOOKLET A

9 May 2017

Total Time for Booklets A and B: 1 hour 45 minutes

**28 questions
56 marks**

**Do not open this booklet until you are told to do so.
Follow all instructions carefully.**

This paper consists of 20 printed pages.

Section A (28 x 2 marks = 56 marks)

For each question from 1 to 28, four options are given. One of them is the correct answer. Make your choice (1, 2, 3 or 4). Shade the correct oval (1, 2, 3 or 4) on the Optical Answer Sheet provided.

1. Study the flow chart below.

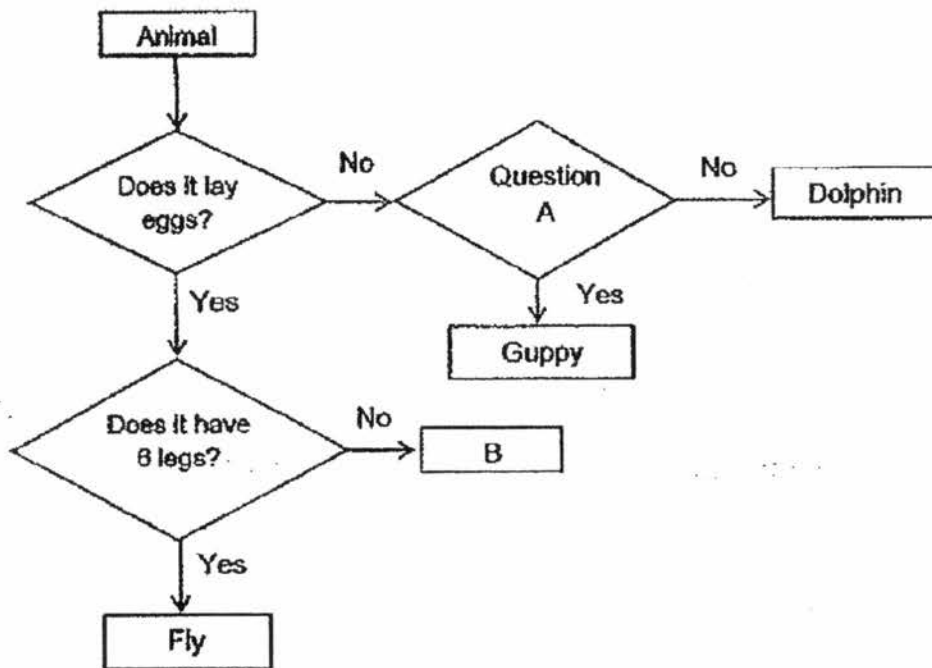

Which of the following correctly shows what Question A and animal B could be?

	Question A	B
(1)	Does it have hair?	Ladybird
(2)	Does it have scales?	Bat
(3)	Does it breathe through lungs?	Duck
(4)	Does it breathe through gills?	Spider

2. Study the table shown below.

Body System A	Body System B	Body System C
Heart	Nose	Mouth
Lungs	Gullet	Stomach
Blood vessels	Diaphragm	Large Intestine

Which of the above organs have been classified wrongly?

- (1) Lungs and stomach only
- (2) Lungs and gullet only
- (3) Gullet and mouth only
- (4) Diaphragm and mouth only

3. Which of the following statements is true for all amphibians?

- (1) They lay eggs.
- (2) They live on land only.
- (3) They live in water only.
- (4) They only breathe through their gills.

4. Meiling observed a seed as it germinated into a young plant. She recorded her observations as shown below.

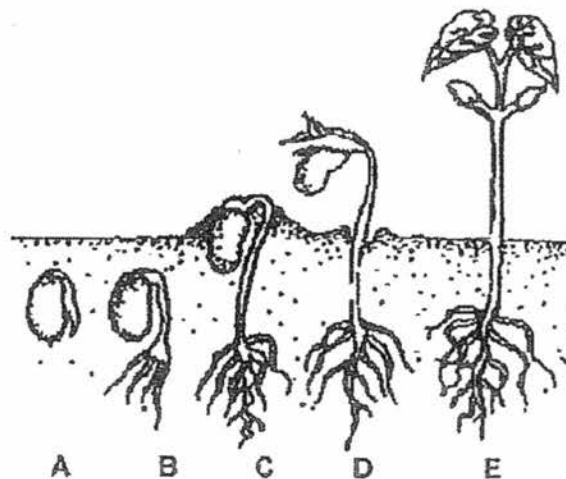

At which stages do the germinating seed take in oxygen?

- (1) A and B only
- (2) A, B and C only
- (3) C, D and E only
- (4) A, B, C, D and E

5. Which of the following comparisons between photosynthesis and respiration are correct?

	Respiration	Photosynthesis
A	Oxygen is produced	Oxygen is needed
B	Water is produced	Water is needed
C	Carbon dioxide is produced	Carbon dioxide is needed
D	Takes place all the time	Takes place where there is light

- (1) A and B only
 (2) B and D only
 (3) A, C and D only
 (4) B, C and D only

6. The graph below shows the number of days for each stage of the life cycle of organisms X and Y.

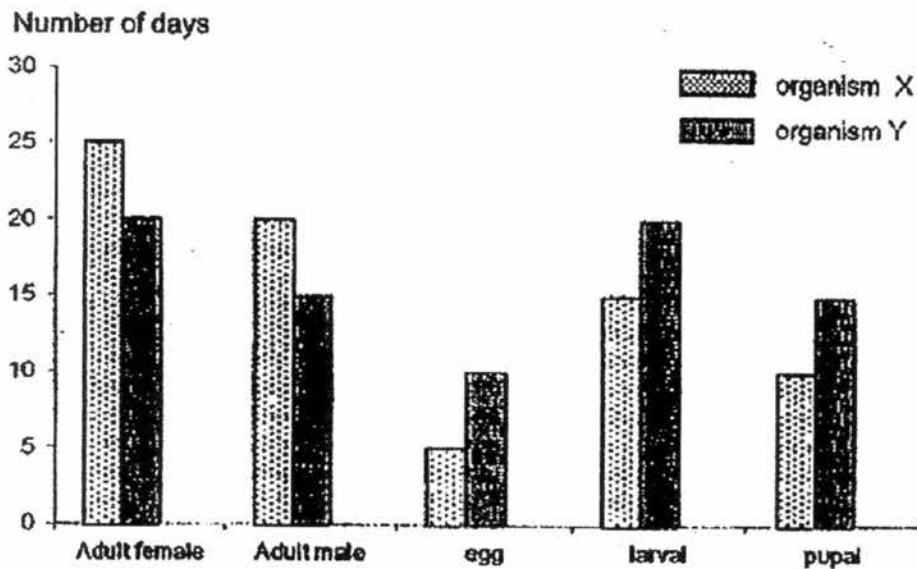

Which of the following shows the stages that organism X and Y would be on the 15th day after the eggs have been hatched?

	Organism X	Organism Y
(1)	larval	larval
(2)	larval	pupal
(3)	pupal	adult
(4)	adult	adult

7. Which of the following set-ups can be used to show that plants take in water?

(1)

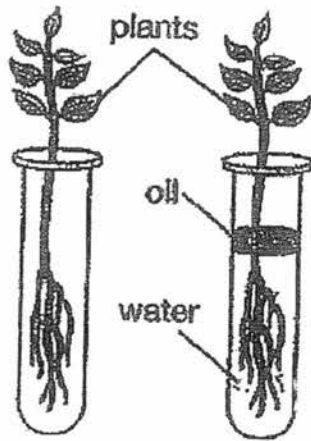

(2)

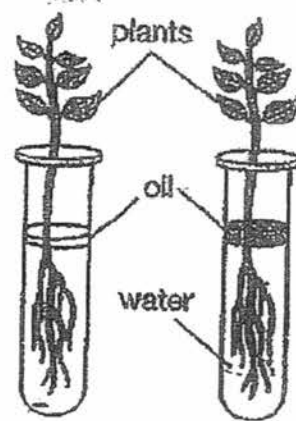

(3)

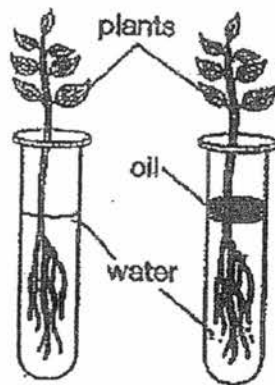

(4)

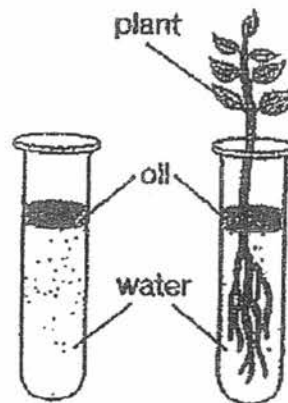

8. The graph below shows the changes in the composition of air in a lift where five people are trapped in.

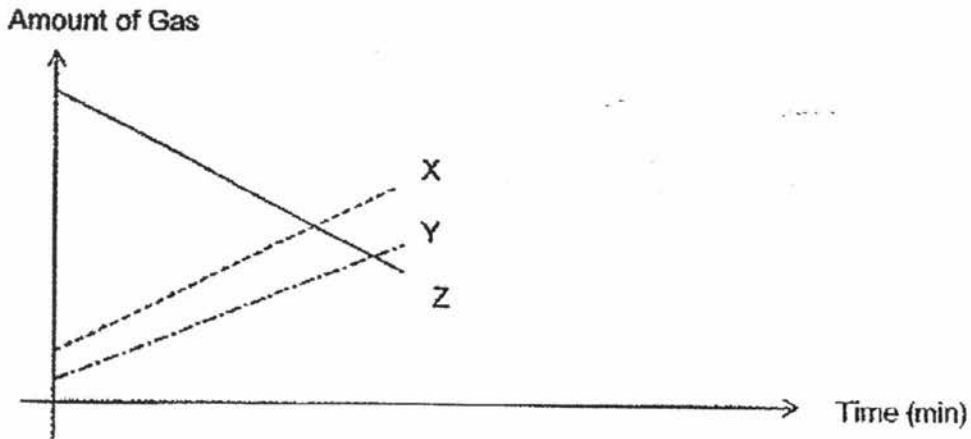

What gases do X, Y and Z represent?

	X	Y	Z
(1)	oxygen	water vapour	carbon dioxide
(2)	carbon dioxide	water vapour	oxygen
(3)	nitrogen	carbon dioxide	oxygen
(4)	carbon dioxide	oxygen	water vapour

9. The gills of a fish consist of feather-like gill filaments as shown below.

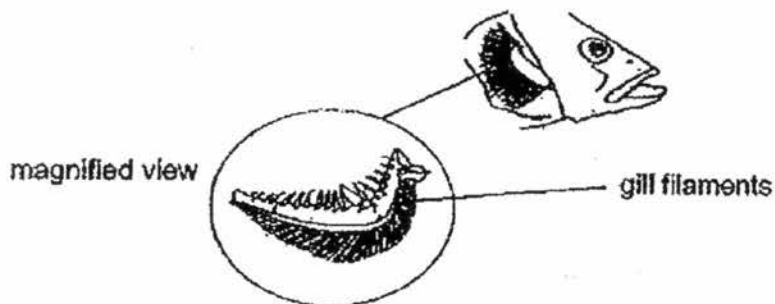

The gill filaments of the fish have many blood vessels to _____.

- A: allow gaseous exchange to take place at a faster rate.
- B: increase the surface area in contact for the absorption of oxygen.
- C: absorb dissolved carbon dioxide from the water at a faster rate.
- D: allow dissolved carbon dioxide to pass from the bloodstream to the water.

- (1) A and B only
- (2) B and C only
- (3) A, B and C only
- (4) A, B and D only

10. The diagram below represents a magnified view of an air sac and a blood vessel in a human body.

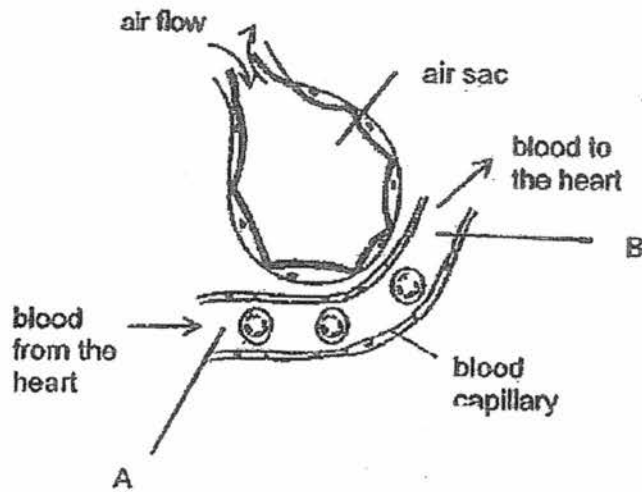

Which one of the following correctly describes the level of carbon dioxide in A and B?

	A	B
(1)	High	High
(2)	Low	High
(3)	High	Low
(4)	Low	Low

11. The table below shows the boiling points and melting points of 4 different substances P, Q, R and S.

Substance	Boiling point ($^{\circ}\text{C}$)	Melting point ($^{\circ}\text{C}$)
P	20	-5
Q	78	15
R	105	23
S	178	50

Which of the substances P, Q, R and S, are in liquid state at 28°C ?

- (1) P and S only
 (2) Q and R only
 (3) P, Q and R only
 (4) Q, R and S only

12. The diagram below shows how food and various gases are transported in the human body

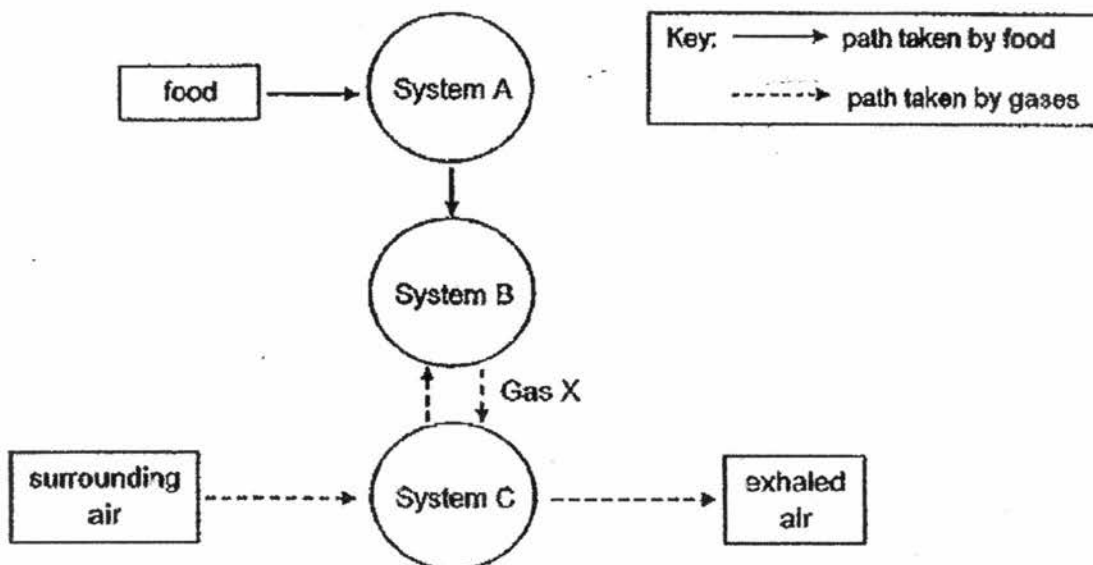

Which systems do P, Q and R represent and what is gas X?

	System A	System B	System C	Gas X
(1)	circulatory	respiratory	digestive	carbon dioxide
(2)	digestive	circulatory	respiratory	carbon dioxide
(3)	circulatory	digestive	respiratory	oxygen
(4)	respiratory	circulatory	digestive	oxygen

13. Which one of the following diagrams shows how food is transported in a plant?

(1)

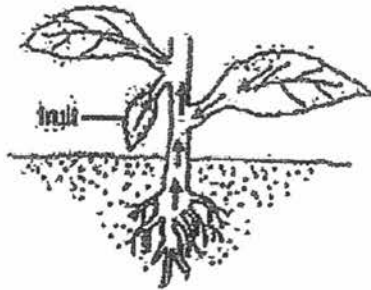

(2)

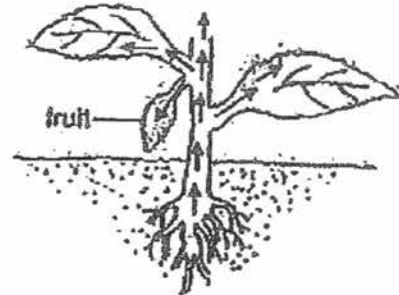

(3)

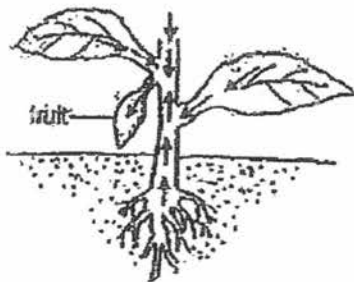

(4)

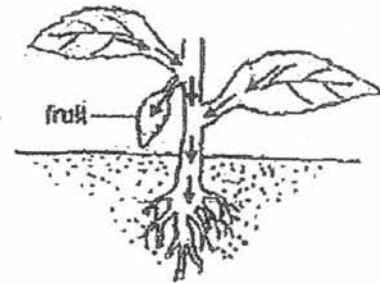

14. The diagram below shows a cross-section of a stem.

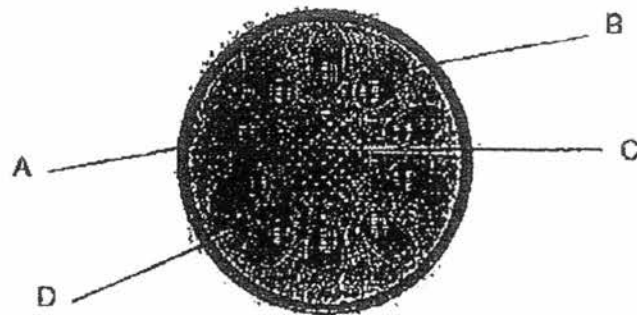

An aphid is found to be feeding on food made by the plant during photosynthesis. Which part of the stem will the aphid most likely insert its feeding tube into?

- (1) A only
- (2) B only
- (3) B and D only
- (4) A, B and C only

- 15 The chart below shows how four cells W, X, Y and Z, are classified.

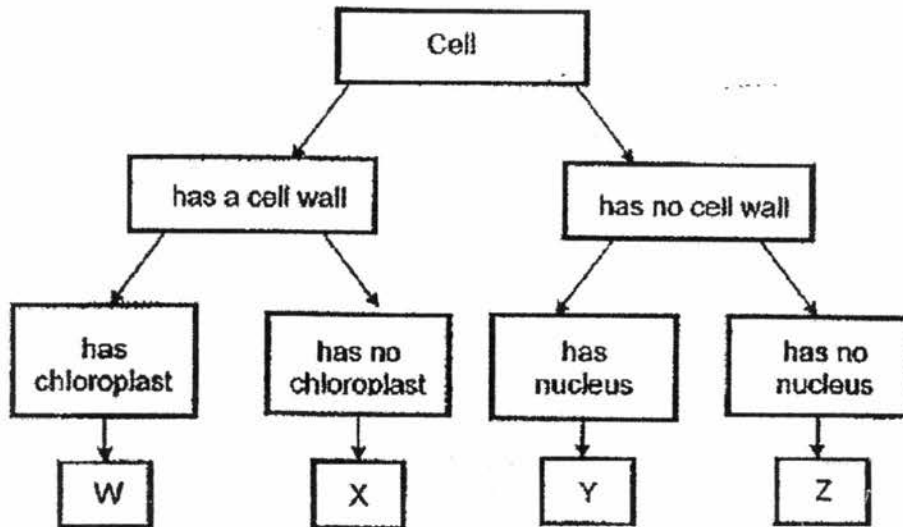

Which of the following statements are true?

- A: Cell Z has a regular shape.
- B: Cell W can trap sunlight.
- C: Cell Y can be taken from the cheek.
- D: Cells W and X can be found in the leaf of the plant.

- (1) A and C only
- (2) A and D only
- (3) B and C only
- (4) B and D only

16. Study the diagram below.

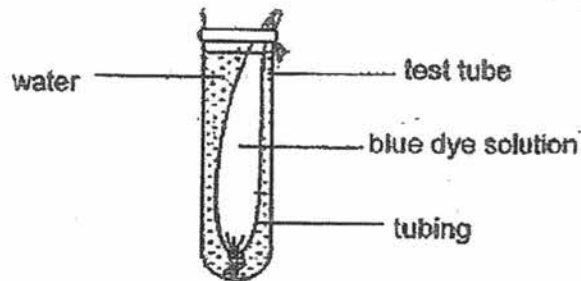

Which of the following explains why the size of the tubing becomes bigger after some time?

- (1) The tubing is fully permeable and allows water particles to pass through.
- (2) The tubing is fully permeable and allows the blue dye particles to pass through.
- (3) The tubing is semi-permeable and allows the water particles to pass through but the blue dye particles are too large to move out of the tubing.
- (4) The tubing is semi-permeable and allows both the particles of water and blue dye to move out of the tubing.

17. Johnson suspended 4 magnets A, B, C and D, above a tray of pins. The result is shown below.

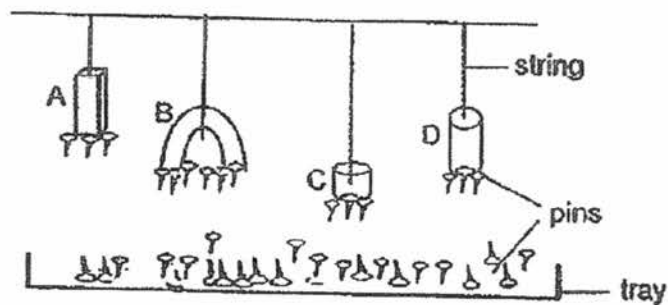

What can you conclude from the result of his experiment?

- (1) A is weaker than B.
- (2) A is stronger than D.
- (3) C is stronger than D.
- (4) B is the strongest magnet.

18. Study the flow chart below.

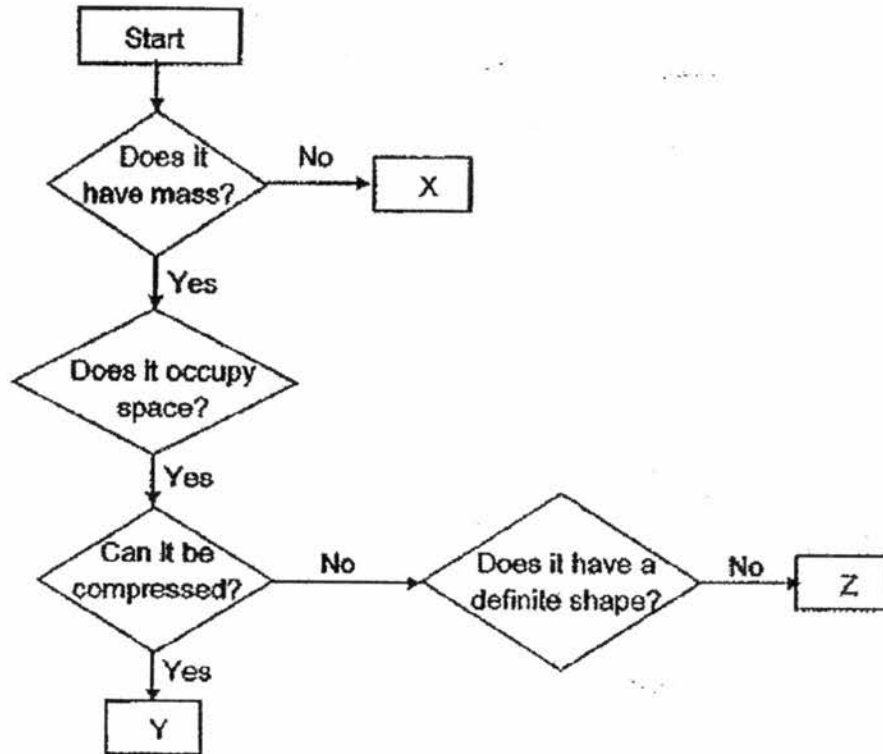

Which one of the following correctly identifies X, Y and Z?

	X	Y	Z
(1)	shadow	oxygen	sand
(2)	ice	nitrogen	flour
(3)	light	water vapour	milk
(4)	steam	air	soap

19. An experiment was conducted to test the strength of four different materials M, N, O and P. Weights of the same mass were hung on the different materials until they snapped.

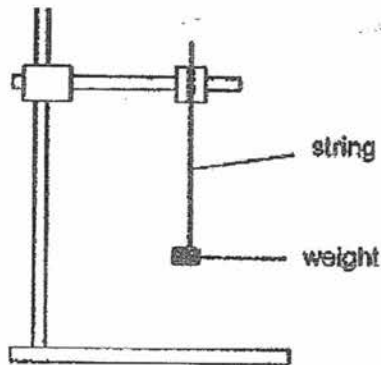

Results of the experiment are recorded in the table below.

Material	M	N	O	P
No. of weights before the material snapped	15	23	10	8

Which one of the following shows the correct order of strength for materials M, N, O and P from the weakest to the strongest?

	Weakest			Strongest
(1)	P	O	M	N
(2)	P	M	O	N
(3)	N	O	M	P
(4)	N	M	O	P

20. Aisha set up a circuit as shown below. She observed that only bulb A lit up. She then exchanged X with Y and observed that no bulb lit up.

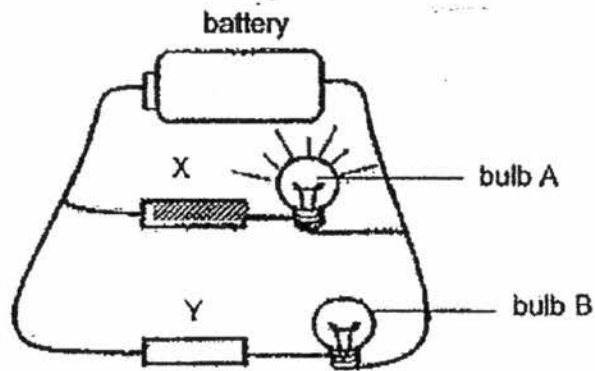

Which one of the following is correct?

	Electrical insulator	Bulb not working
(1)	X	A
(2)	X	B
(3)	Y	A
(4)	Y	B

21. Bulbs A, B and C lit up when they were connected as shown below.

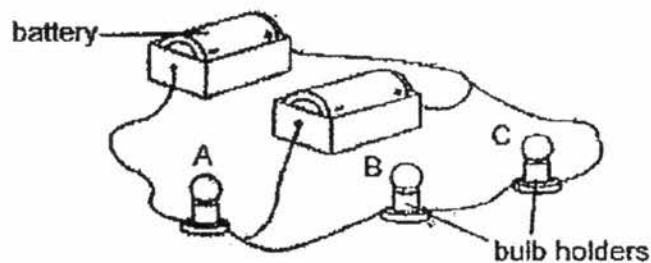

What will happen to bulbs A and B if bulb C is removed from the bulb holder?

- (1) Both bulbs A and B will not light up.
- (2) Bulb A will light up but bulb B will not.
- (3) Bulb A will give out a brighter light than bulb B.
- (4) Bulb B will give out a brighter light than bulb A.

22. Alex set up the following circuit with four materials W, X, Y and Z, of similar size.

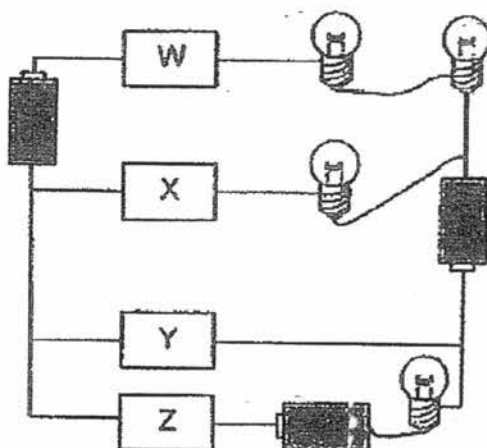

He observed that only one bulb was lit. Which one of the following is correctly represented by materials W, X, Y and Z, in the above circuit?

	Material W	Material X	Material Y	Material Z
(1)	aluminium	glass	porcelain	copper
(2)	silver	copper	glass	steel
(3)	silver	iron	copper	aluminium
(4)	porcelain	aluminium	iron	plastic

23. The diagram below shows a circuit tester and a circuit card. A, B, C, D and E are paperclips on the circuit card. Wires connecting some of the paper clips are concealed.

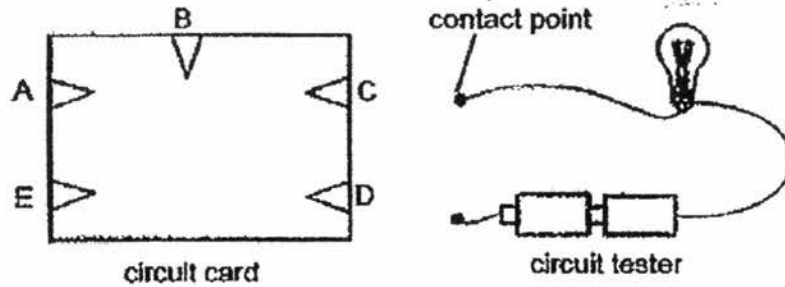

The table below shows the results obtained when the contact points on the circuit tester are connected to different pairs of paper clips on the circuit card shown above.

Pair of connected paperclips	Does the bulb light up?
A and C	No
A and D	No
B and C	Yes
B and D	Yes
B and E	Yes
D and E	Yes

Based on the results shown in the table above, which one of the following shows the correct connection of the wires behind the circuit card?

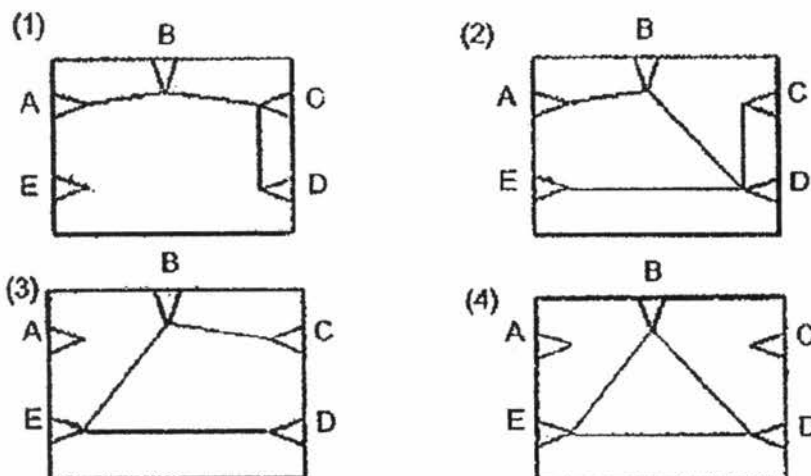

24. Martin carried out an experiment in a dark room. He arranged 4 sheets made of different materials S, T, U and V, in a straight line as shown below. When the torch was switched on, he observed that a bright patch of light in the shape of a star was seen on sheet U only.

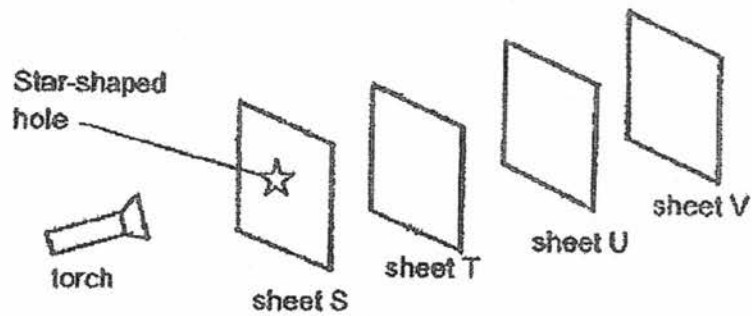

Which of the following statements is/are true about the sheets used above?

- A: Sheet S is opaque.
- B: Sheet T is transparent.
- C: Sheet U is translucent.
- D: Sheet V is opaque.

- (1) A only
- (2) A and B only
- (3) B and D only
- (4) B, C and D only

25. Samy carried out an experiment with the set-up shown below.

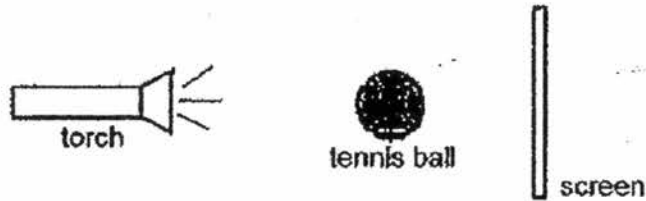

He wrote down what he did for his experiment.

- A Switch on the torch.
- B Measure the height of the shadow of the tennis ball cast on the screen.
- C Move the tennis ball 5 cm closer to the torch.
- D Measure the height of the shadow again.
- E Repeat steps (C) and (D) twice, moving the tennis ball 5 cm closer to the torch

Which one of the following statements is the correct hypothesis for his investigation?

- (1) The bigger the screen, the bigger the size of the shadow cast,
 - (2) The brightness of the torch will affect the size of the shadow.
 - (3) The distance between the torch and the tennis ball will affect the height of the shadow.
 - (4) The distance between the torch and the screen will affect the height of the shadow.
26. Susila wanted to find out how the temperature of water affects the rate at which sugar dissolves. She used sugar cubes of similar size and 4 identical beakers to set up her experiment. Details of her experiment are shown in the table below.

Beaker	Number of sugar cube	Temperature of water (°C)	Amount of water (ml)
W	2	90	600
X	1	30	600
Y	1	90	500
Z	1	40	500

Which beakers should Susila compare?

- (1) W and X
- (2) W and Y
- (3) Y and Z
- (4) X and Y

27. A group of students carried out an experiment using a beaker of ice cubes. They heated the beaker of ice cubes and then left it on a table to cool. They observed the changes in temperature at regular intervals and plotted a graph as shown below.

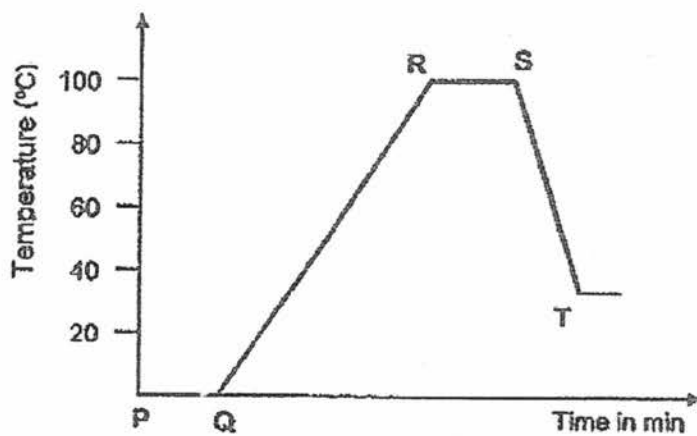

Which part(s) of the graph PQ, QR, RS, ST show(s) heat gained during their experiment?

- (1) QR only
- (2) ST only
- (3) PQ and QR only
- (4) PQ, QR and RS only

28. Ben filled two identical metal cans X and Y, with 150 cm^3 of water at 80°C . Next, he wrapped a strip of metal P around can X and a strip of metal Q around can Y, as shown in the diagram below. The metal strips were of the same length and thickness.

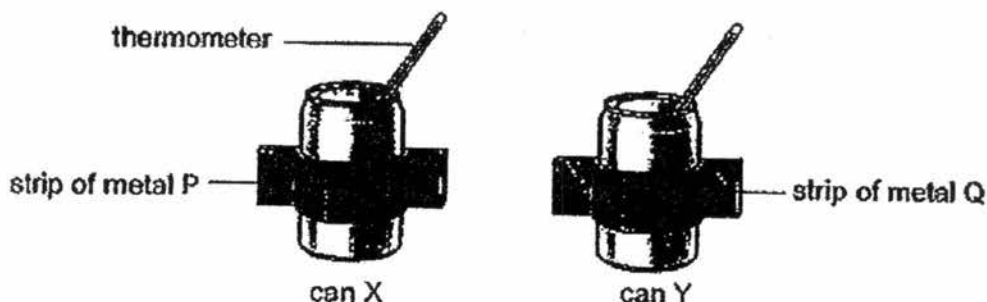

Ben recorded the temperature of the water in each can at 5-min intervals for 20 minutes in the table below.

Time (min)	Temperature of water in the can ($^\circ\text{C}$)	
	X	Y
0	80	80
5	64	60
10	53	49
15	51	48
20	48	43

Which of the following statements are correct?

- A Can Y is a better conductor of heat than can X.
 - B Metal Q is a better conductor of heat than metal P.
 - C The temperature of water in can Y drops more quickly than that in can X.
 - D The water in can X gains heat more quickly from the surroundings than the water in can Y.
- (1) A and B only
 (2) B and C only
 (3) C and D only
 (4) A, B and C only

~~ End of Section A ~~

Name : _____ ()

Class : Primary 5 _____

CHIJ ST NICHOLAS GIRLS' SCHOOL



Primary 5

Semestral Assessment 1 – 2017

SCIENCE

BOOKLET B

9 May 2017

Total Time for Booklets A and B: 1 hour 45 minutes

13 questions
44 marks

Do not open this booklet until you are told to do so.
Follow all instructions carefully.
Answer all questions.

This booklet consists of 18 printed pages.

Booklet A	56
Booklet B	44
Total	100

Parent's Signature/Date

Section B (44 marks)

For questions 29 to 41, write your answers in this booklet.

The number of marks available is shown in the brackets at the end of each question or part question.

29. John planted an equal number of similar bean seeds in 3 trays and placed them under different temperatures shown below. The seeds were provided the same amount of sunlight, the same type of garden soil and watered with the same volume of water daily for six days.

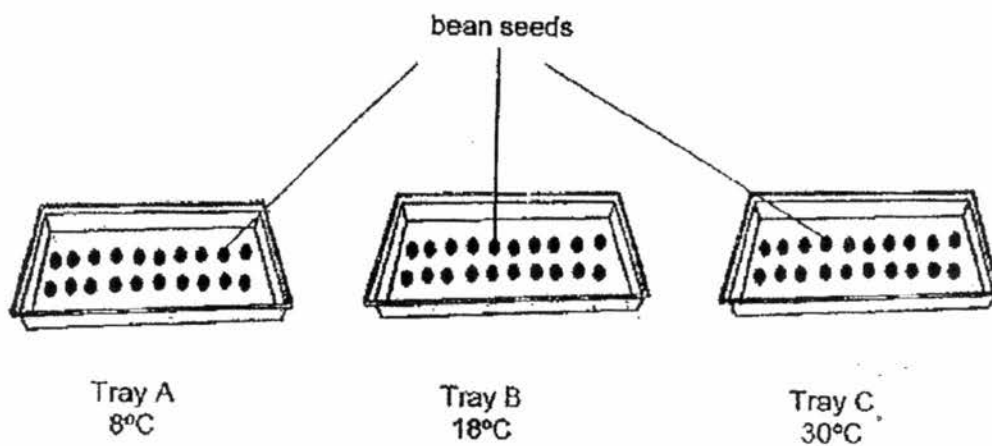

The results are shown in the table below.

Tray	Temperature (°C)	Total number of seeds germinated					
		Day 1	Day 2	Day 3	Day 4	Day 5	Day 6
A	8	0	0	0	0	1	1
B	18	0	0	0	1	4	6
C	30	0	5	8	13	17	20

- (a) What was the aim of the experiment?

[1]



(b) Based on the results in the table, indicate with a tick (✓) whether each of the statement is True, False or Not Possible To Tell.

[2]

Statements	True	False	Not Possible To tell
The temperature of 8 °C was too cold for the seeds to germinate.			
All types of seeds germinate best at the temperature of 30 °C.			
The earliest germination was observed in seeds placed at the temperature of 30 °C.			
The seeds would not germinate above the temperature of 30 °C.			



30. Rita studied the life cycle of organism W shown below.

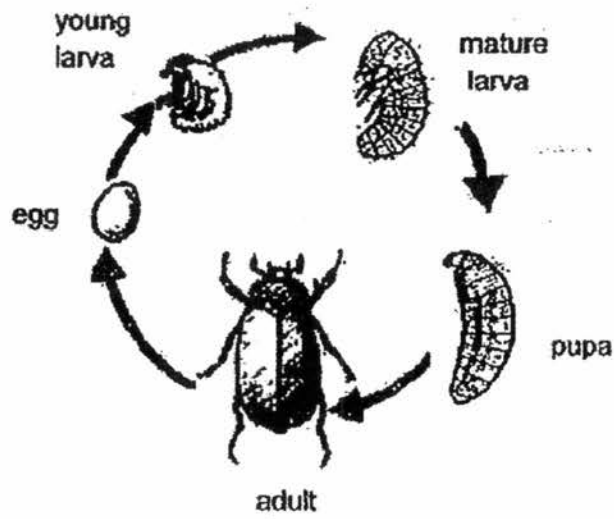

(a) Organism W is an insect. Give 2 reasons to support this statement.

[1]

Reason 1 :

Reason 2 :

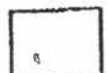

- (b) Rita studied the effect of surrounding temperature on the life cycle of organism W. Her findings are shown below.

Temperature (°C)	Number of days for one complete life cycle
15	48
20	22
25	15
30	9
35	7

- (i) Based on Rita's findings, how would temperature affect the length of one complete life cycle of organism W. [1]

- (ii) Organism W lays its eggs which hatch into larvae in decaying animal bodies. The larvae grow in size after some time. Suggest and explain 2 benefits for organism W when it lays its eggs in decaying animal bodies. [2]

Benefit 1 :

Benefit 2 :

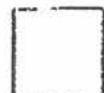

31. Study the flow chart below.

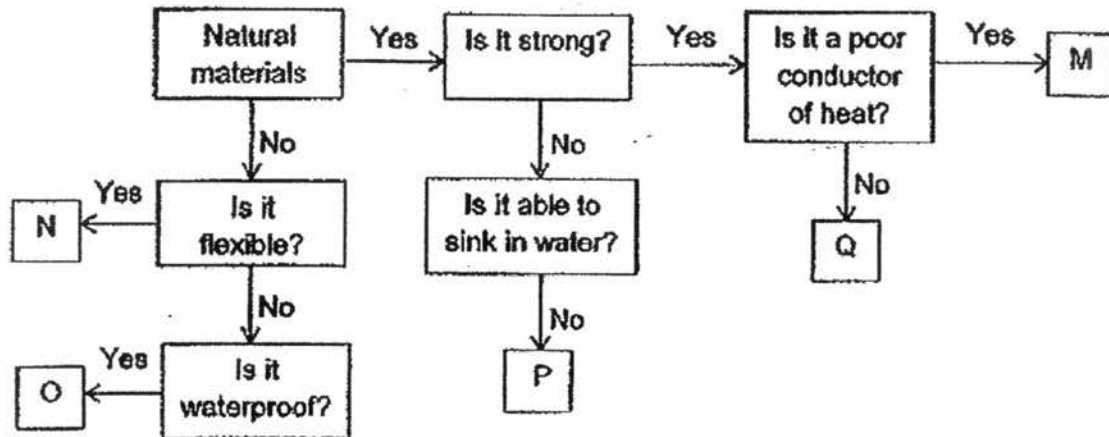

(a) Based on the flow chart above, write the letter M, N, O and P in the boxes that best represent the objects shown in the box below. [2]

	Objects	Letter
(i)	Car tyre	
(ii)	Raincoat	
(iii)	Wooden chopsticks	
(iv)	Ceramic pot	

(b) State all the characteristics of object Q. [1]

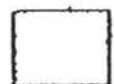

32. Edward discovered cell A in a sample of pond water shown below. Upon microscopic examination, he noticed that cell A moves about using its tail-like structure called flagellum.

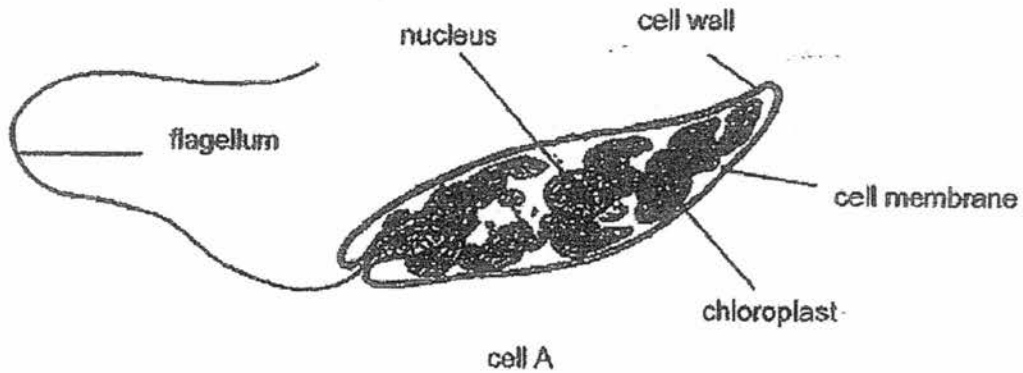

- (a) Based on the diagram, Edward thinks that cell A is more likely to be a plant cell than an animal cell. Explain why. [2]

- (b) Would cell A need to depend on other organisms for food? Explain your answer. [1]



33. Ravi measured the breathing rates of various age groups of children (between 4 to 16 year olds) at rest. His findings are plotted in a graph shown below.

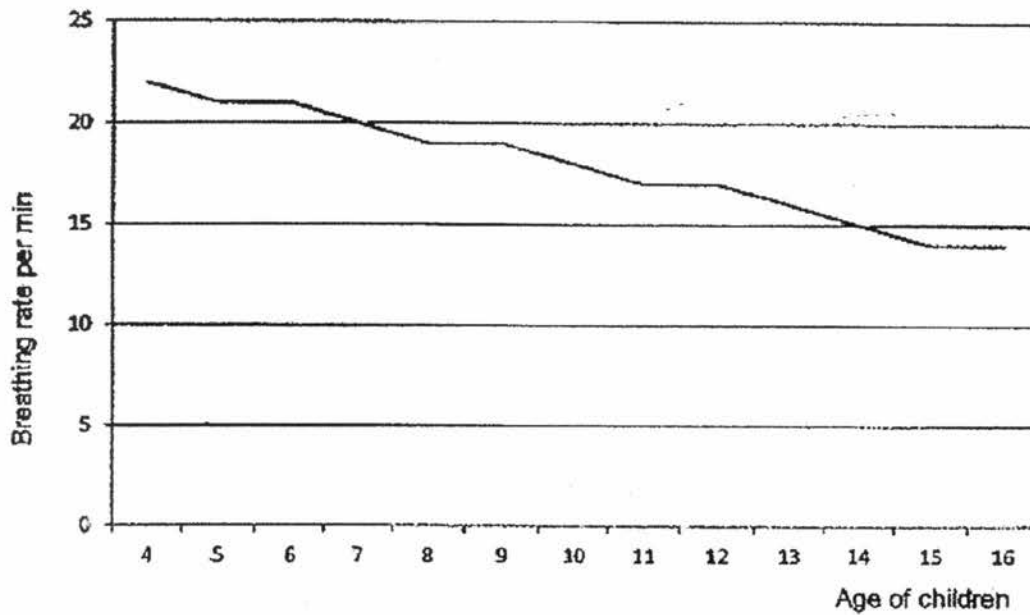

- (a) What is the relationship between the breathing rate and the age of the children? [1]

- (b) These children were allowed to run for 10 minutes. Ravi measured their breathing rates again and found that all their breathing rates have increased. Explain why. [1]

- (c) Which system in the human body is similar to the transport system of a plant? [1]



34. Jovi placed a healthy plant in a beaker of red-coloured water as shown below. He sealed the top of the beaker with some aluminium foil. Two days later, Jovi observed that the flowers had turned red.

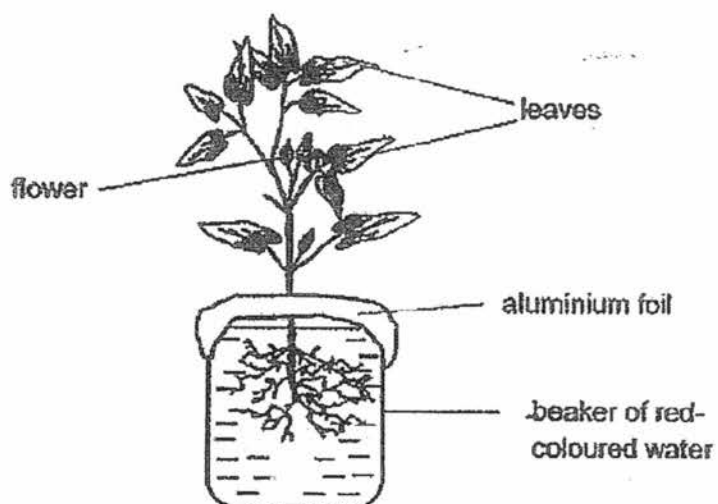

- (a) Explain why the flowers turned red? [1]

- (b) Jovi repeated the experiment with a similar set-up, but without the aluminium foil. [1]
Would the flowers in the second set-up turn red too? Explain your answer.



35. Siew Choo set up the experiment below to find out how water plants affect the percentage of dissolved carbon dioxide in water at different times of the day.

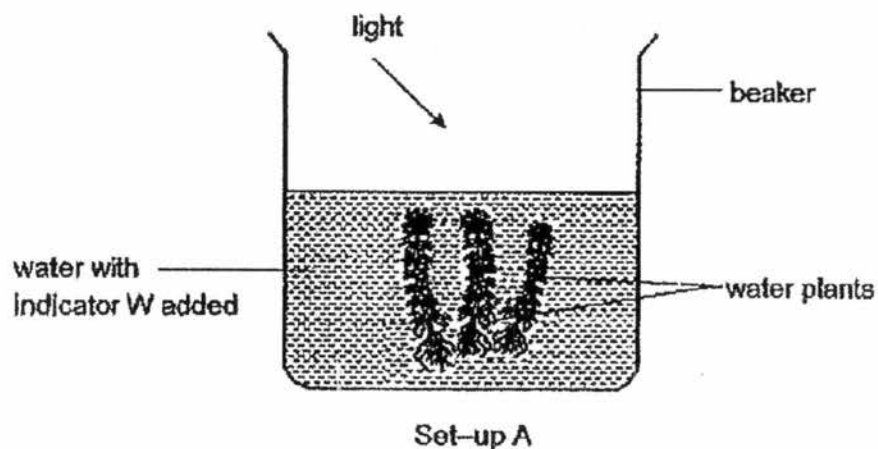

She placed set-up A near a window and added a few drops of indicator W to the beaker of water. Indicator W changes colour according to the percentage of dissolved carbon dioxide in the water as shown in the table below.

Percentage of dissolved carbon dioxide in water	Less than 0.03%	Normal (0.03%)	More than 0.03%
Indicator W colour change	purple	red	yellow

- (a) Write down the colour of the water. [1]
- (i) At 12.30 pm, in the afternoon: _____
- (ii) At 11.30pm, at night: _____

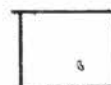

- b. Siew Choo repeated the experiment by adding some fish to a similar set-up B shown below.

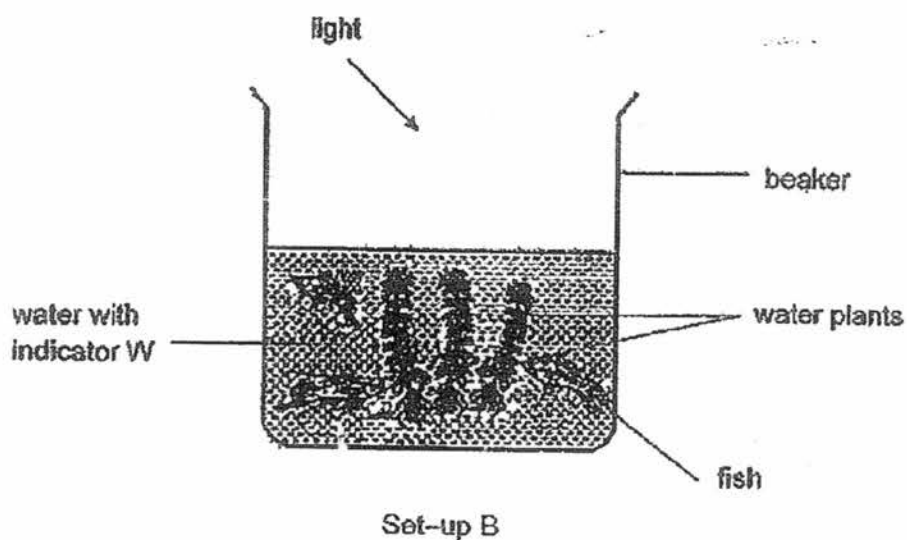

- (i) She predicted that the colour of the water at 12.30 pm for set-up B would be yellow [2] because there would be more dissolved carbon dioxide in the water. Explain why her prediction may not be correct.



36. Edison pushed an empty inverted bottle without a cap, vertically down into a basin of water as shown below. He noticed that the water level in the basin had risen.



- (a) State another observation that he would likely see. Explain your answer. [2]

Next, he tilted the inverted bottle at an angle under water as shown below.



- (b) State one observation Edison would likely see. [1]

- (c) Explain Edison's observation in (b) [1]

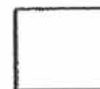

37. The bulbs and batteries in the circuit below are identical.

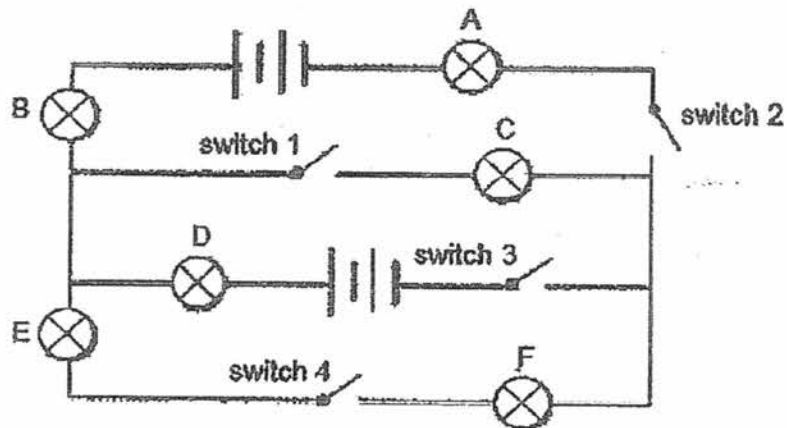

Complete the table below by writing the total number of bulbs that will light up when the stated switches are closed.

[2]

Switches that are closed	Bulb(s) that light up
S1 & S4	
S1 & S3	
S2 & S3	
S2 & S4	



38. Study the circuit diagram below carefully. Three different materials A, B and C, were placed at positions 1, 2 and 3 as shown. All the bulbs were identical and functioning properly prior to the experiment

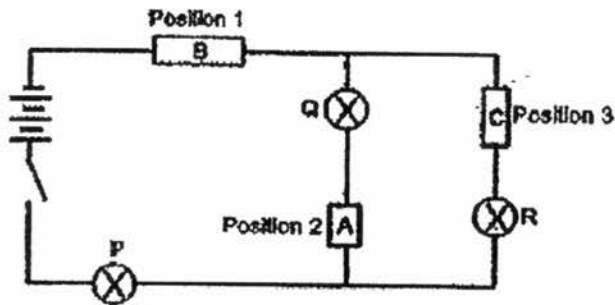

- (a) When the circuit was closed, it was observed that only bulb Q did not light up. [1]
Give one possible reason.

The positions of materials A, B and C were then rearranged as shown below.

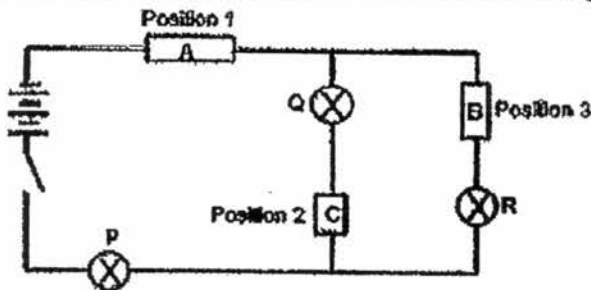

- (b) Write the words lit or unlit in the correct boxes below to indicate whether bulbs P, Q and R will light up when the circuit was closed. [2]

Bulb		
P	Q	R

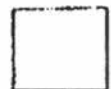

39. The diagram below shows a model of a solar water heater. A water pump is used to circulate the water in the set-up. The plastic water tank and plastic tube are filled with cold water. The tray is left in the sun while the plastic water tank is kept in the shade.

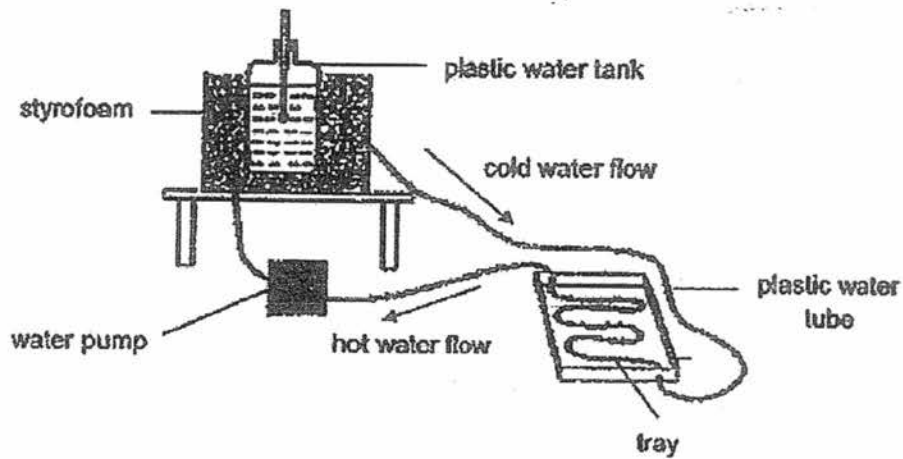

- (a) Name a suitable material for making the tray. Give a reason for your choice. [1]
- _____
- _____
- (b) What is the purpose of the styrofoam around the plastic water tank? [1]
- _____
- _____
- (c) Suggest another material to replace the styrofoam in the set-up. [1]
- _____
- _____
- (d) If we increased the number of coils on the tray without changing the length of the plastic tube, water could be heated up faster. Do you agree? [2]
Explain your answer.
- _____
- _____
- _____

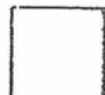

40. Kevin conducted an experiment to find out how the amount of light reflected by three different materials A, B and C, is affected by the distance the material is away from the light source.

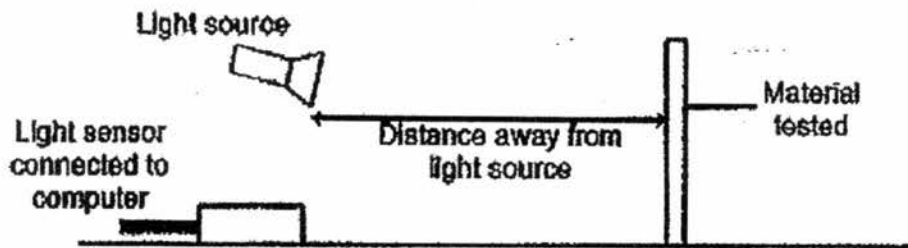

Kevin placed the materials A, B and C at different distances away from the light source and he used a light sensor to determine the amount of light that was reflected.

He recorded the results and plotted the results in the graph below.

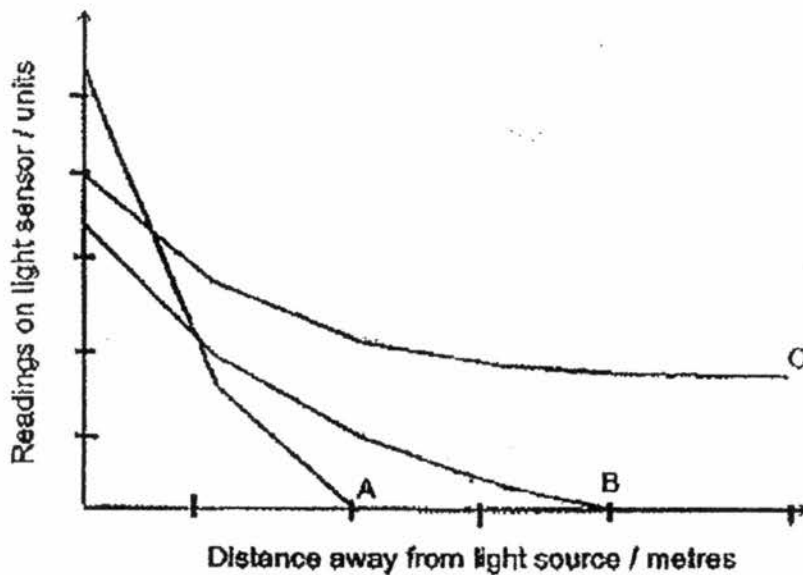

- (a) Explain why Kelvin should conduct his experiment in a dark room to ensure a fair test. [1]

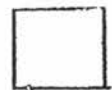

- (b) State two variables that Kevin would have to keep constant to ensure a fair test.

- (c) Based on the results of his experiment, which material A, B and C, would be most suitable for making safety road signs for motorists to warn them of danger on the roads in the night? Explain your answer. [2]



41. Each of the three metal bars A, B and C, was suspended with a string as shown in the diagram.

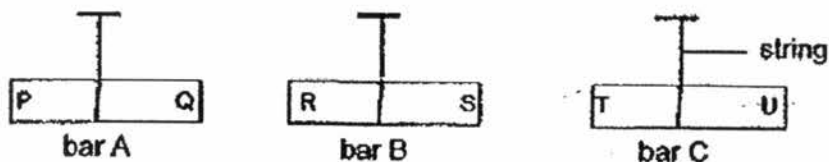

Diagram 1 below shows what happened when bars A, B and C were brought together.

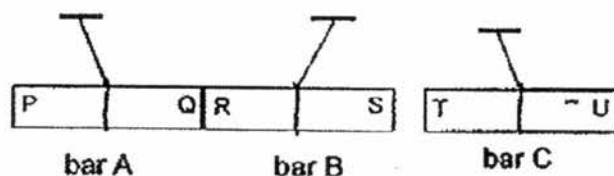

diagram 1

Diagram 2 below shows what happened when bar A and bar C were brought together.

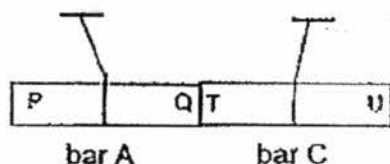

diagram 2

Based on the results above, state whether each of the following statements is True (T) or False (F). [4]

	Statement	True or False
A	Ends S and T are like poles.	
B	Ends P and U are unlike poles.	
C	Only bars B and C are magnets.	
D	Bar A is made of a non-magnetic material.	

--- End of Paper ---



EXAM PAPER 2017 (P5)

SCHOOL : CHIJ ST

SUBJECT : SCIENCE

TERM : SA1

Q1	Q2	Q3	Q4	Q5	Q6	Q7	Q8	Q9	Q10
4	2	1	4	4	1	4	2	1	3
Q11	Q12	Q13	Q14	Q15	Q16	Q17	Q18	Q19	Q20
2	2	4	2	3	3	2	3	1	4
Q21	Q22	Q23	Q24	Q25	Q26	Q27	Q28		
1	4	3	2	3	3	4	2		

29)a)To find out whether the temperature surroundings affect the rate of germination of the seeds.

b)False

Not Possible To Tell

True

Not Possible To Tell

30)a)Reason 1:Insects have 6 legs and organisms W has 6 legs.

Reason 2:Insects have 3 body parts and organisms W has 3 body parts.

b)i)The lower the surrounding temperature,the more more days need for one complete life cycle of organisms W.

ii)Benefit 1:There will be enough food as the larvae can feed on decaying animal bodies.

Benefit 2:It is not easy for the predators to find the young of organisms W inside the decaying animal so they will not be eaten up easily.

31)a)i)M

ii)N

iii)P

iv) O

b)Object Q is a natural material,it is strong and it is a good conductor of heat.

32)a)Cell A has chloroplast and cell wall.Plant cells have chloroplasts and cell wall while animal cells do not.

b)No,cell A would not need to.It has chloroplast that contains chlorophyll and traps sunlight for the plant to make food.

33)a)The older the children ,the lower the breathing rate per minute.

b)More energy is needed during the run so the breathing rate increases to take in more oxygen and remove more carbon dioxide for higher respiration rate.

33)c)Circulatory System

34)a)The roots absorbed the red-coloured water and the water carrying tubes transported it to the other parts of the plants.

b)Yes,the flowers in the second set-up would turn red too.The roots can still absorb the red-coloured water and the water carrying tubes will transport it to other parts of the plant.

35)a)i)Purple

ii)Yellow

b)i)In set-up B ,even though the fish give out carbon dioxide but the plants also take in carbon dioxide for photosynthesis.The amount of carbon dioxide absorbed by the plant may be higher than the amount of carbon dioxide given out by the fish.Thus the colour of the water will not be yellow.

36)a)Some water entered the bottle.Air can be compressed.

b)The water level will drop and the water will flow into the bottle.

c)When it is tilted ,some air in the bottle will escape so water could enter to occupy the space.

37)S1&S4-None

S1&S3-Bulbs C and D

S2&S3-None

S2&S4-Bulbs A,B,E and F

38)a)Material A is an electrical insulator and it does not allow electric current to pass through.

b)P-unlit

Q-unlit

R-unlit

39)a)Steel.It is a good conductor of heat.

b)Styrofoam is a poor conductor of heat so the hot water in the tank will lose heat slower to the surroundings to keep it warmer for longer period of time.

c)Rubber

d)Yes.When the number of coils on the tray increased ,there will be more surface area in contact with the tray, so that the water in the tubes will gain heat faster and get heated up faster.

40)a)To ensure that light that shines on the material is only from the light source and not from the surrounding.

b)The amount of light and the thickness of the material.

c)Material C.It is able to reflect the most light from the furthest distance.Thus it will be able to reflect the most amount of light off material C into the motorists' eye from the greatest distance.

41)A-True

B-False

C-True

D-False