

# TAO NAN SCHOOL

## PRIMARY 5 SCIENCE END-OF-YEAR EXAMINATION – 2009

Name: \_\_\_\_\_ (       )      Date: 29 October 2009

Class: P5 \_\_\_\_\_

Duration: 1h 45min

### BOOKLET A

#### INSTRUCTIONS TO CANDIDATES

Do not open this booklet until you are told to do so.

Follow all instructions carefully.

Answer all questions.

	Score	Marks
Section A		60
Section B		40
Total		100

Parent's signature: \_\_\_\_\_

**Section A (30 x 2 marks)**

For each question from 1 to 30, four options are given. One of them is the correct answer. Make your choice (1, 2, 3 or 4). Shade the correct oval (1, 2, 3 or 4) on the Optical Answer Sheet.

1. Which of the following shows the characteristics of an orchid plant?

	<b>Need water and air?</b>	<b>Can reproduce?</b>	<b>Can respond to changes?</b>
1)	Yes	Yes	No
2)	Yes	No	Yes
3)	Yes	Yes	Yes
4)	No	Yes	Yes

2. The following living things are classified by what they eat.

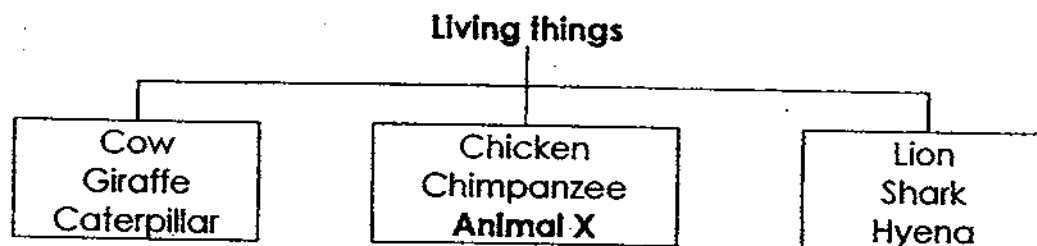

Which of the following animals could **Animal X** be?

- 1) Tiger
- 2) Duck
- 3) Eagle
- 4) Sheep

3. The following picture shows a frying pan.

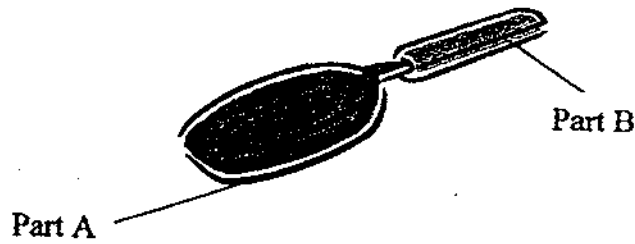

Which materials are suitable for making Part A and Part B?

	Part A	Part B
1)	Steel	Wood
2)	Copper	Glass
3)	Rubber	Iron
4)	Plastic	Ceramics

4. Which of the following matches the life cycles shown below?

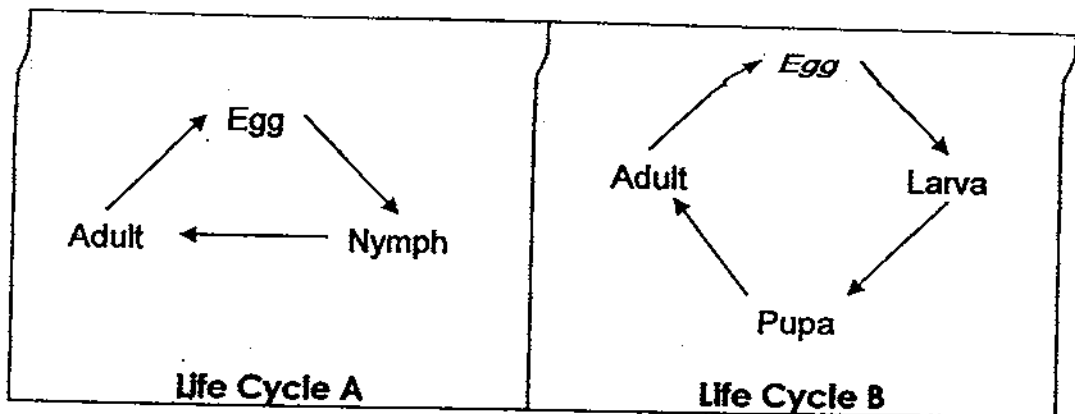

	Life Cycle A	Life Cycle B
1)	Housefly	Dragonfly
2)	Beetle	Mosquito
3)	Grasshopper	Damselfly
4)	Cockroach	Butterfly

5. Tom pumped air into a balloon until it burst. Which characteristic of air best explains what happened?

- 1) Air has mass.
- 2) Air occupies space.
- 3) Air has no fixed shape.
- 4) Air can be compressed.

6. The containers below each contain 1 litre of water. In which of the following containers would the water evaporate the fastest?

1)

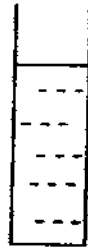

2)

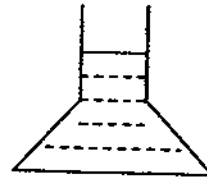

3)

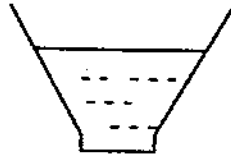

4)

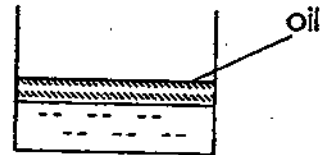

7. Look at the picture of a flower below. Which part of the flower would pollen grains be found?

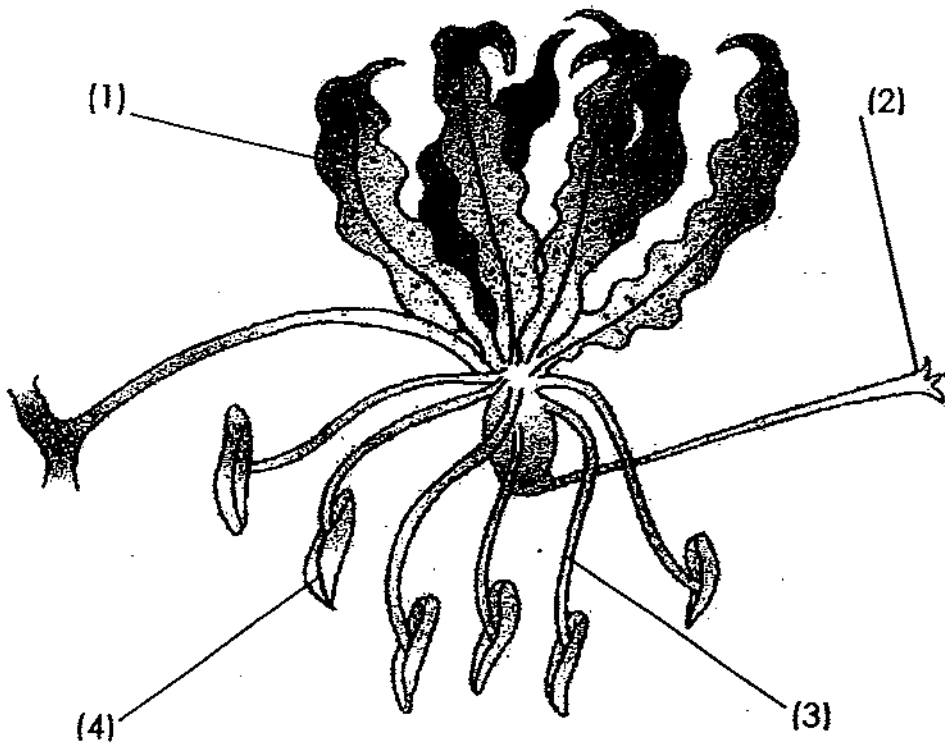



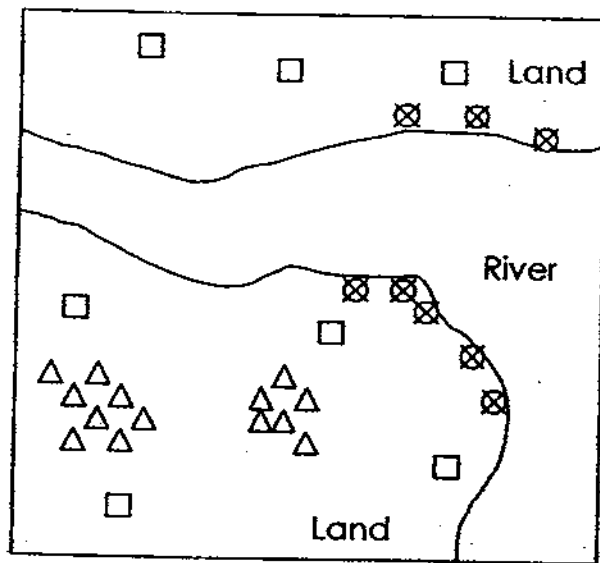





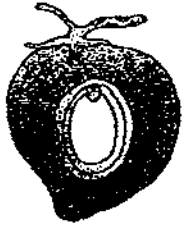
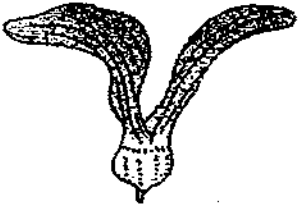

8. The diagram below shows the location of Plant A, Plant B and Plant C near a river mouth.

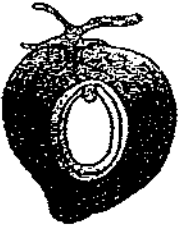
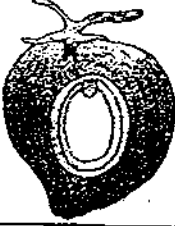

- Plant A
- △ Plant B
- ⊗ Plant C

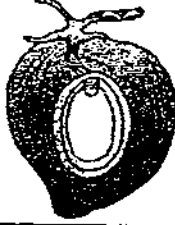
Which of the following matches the plants and their seeds correctly?

	Plant A	Plant B	Plant C
✗			
✗			
✗			
✗			

9. Which of the following shows the characteristics of a flower that is pollinated by an insect?

	Smell of flower	Colour of petals	Size of petals
1)	Scented	Brightly coloured	Big
2)	Scented	Dull	Small
3)	Unscented	Brightly coloured	Small
4)	Unscented	Dull	Big

10. A cup which contained very hot water was covered with a plastic cover as shown below.

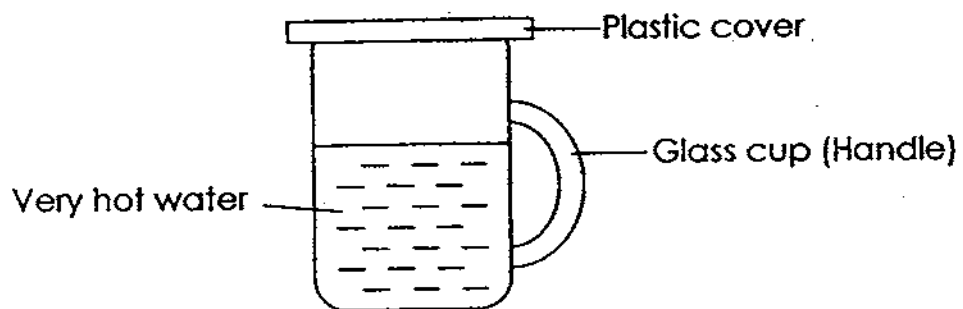

After half an hour, Daren observed some changes. Which of the following shows what Daren observed?

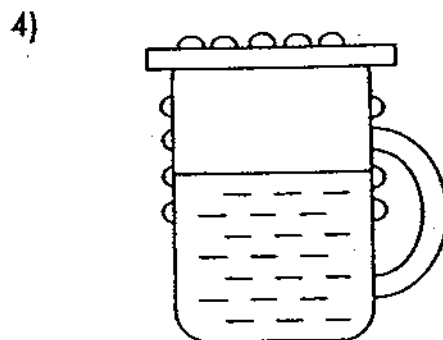
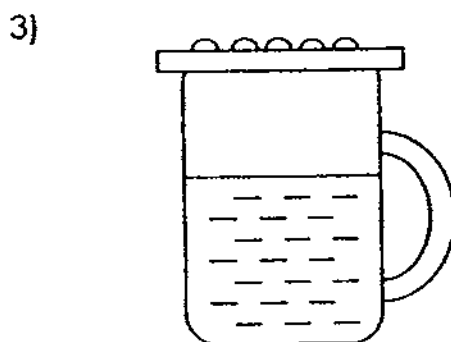
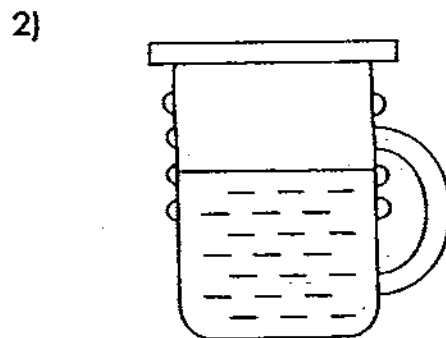
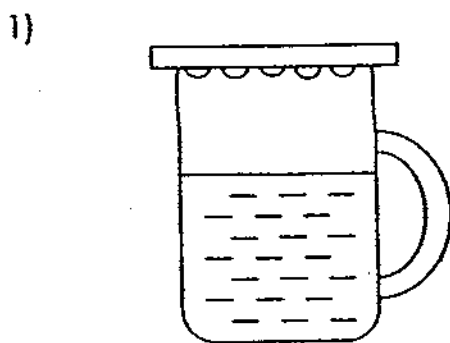

11. Which of the following matches the reproductive organ to its reproductive cell?

	Male		Female	
	Reproductive Organ	Reproductive Cell	Reproductive Organ	Reproductive Cell
1)	Penis	Sperm	Uterus	Ovum
2)	Testis	Sperm	Ovary	Uterus
3)	Anther	Pollen Grains	Ovary	Ovule
4)	Filament	Pollen Grains	Stigma	Ovary

12. Which of the following shows the correct sequence of how a baby develops?

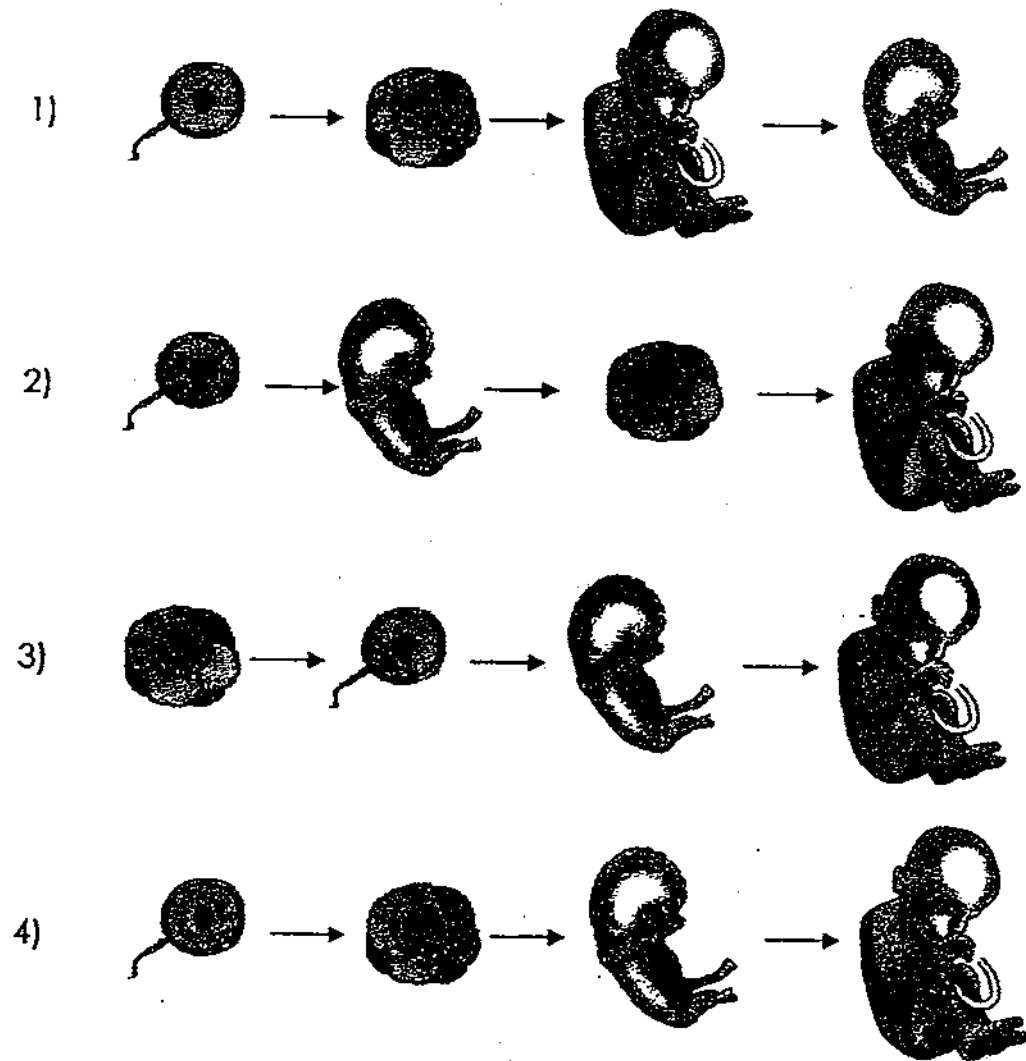

13. Which of the following about sexual reproduction in humans is false?

- 1) A fertilised egg develops in the uterus.
- 2) Many sperms are needed to fertilise an egg.
- 3) Sexual reproduction requires a male and a female.
- 4) Traits of parents are passed to their offspring through sexual reproduction.

14. Study the flowchart below.

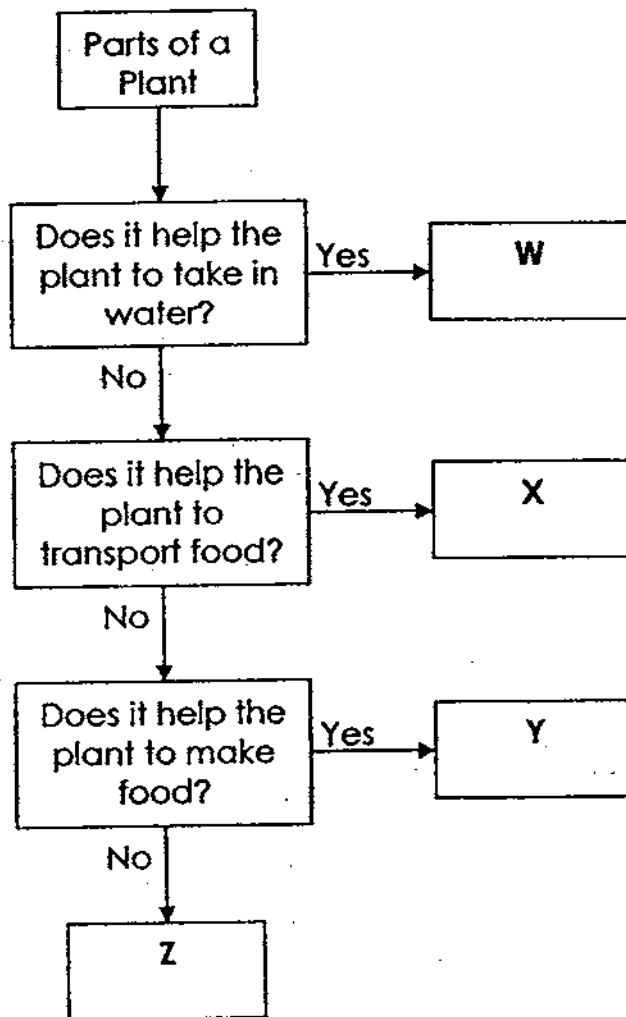

Which of the following identifies W, X, Y and Z?

	W	X	Y	Z
1)	Roots	Phloem Tubes	Leaves	Xylem Tubes
2)	Xylem Tubes	Phloem Tubes	Leaves	Roots
3)	Roots	Leaves	Phloem Tubes	Xylem Tubes
4)	Phloem Tubes	Xylem Tubes	Leaves	Roots



15. Study the picture of the skeleton below.

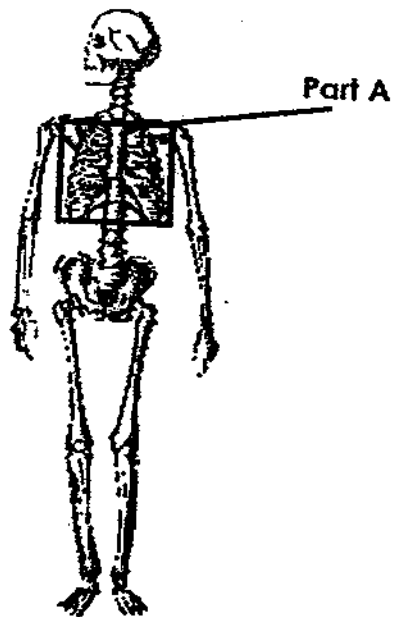

What is the function of Part A?

- 1) It supports the head.
- 2) It holds the body upright.
- 3) It protects important organs.
- 4) It allows the arms to move freely.

16. Study the graph below.

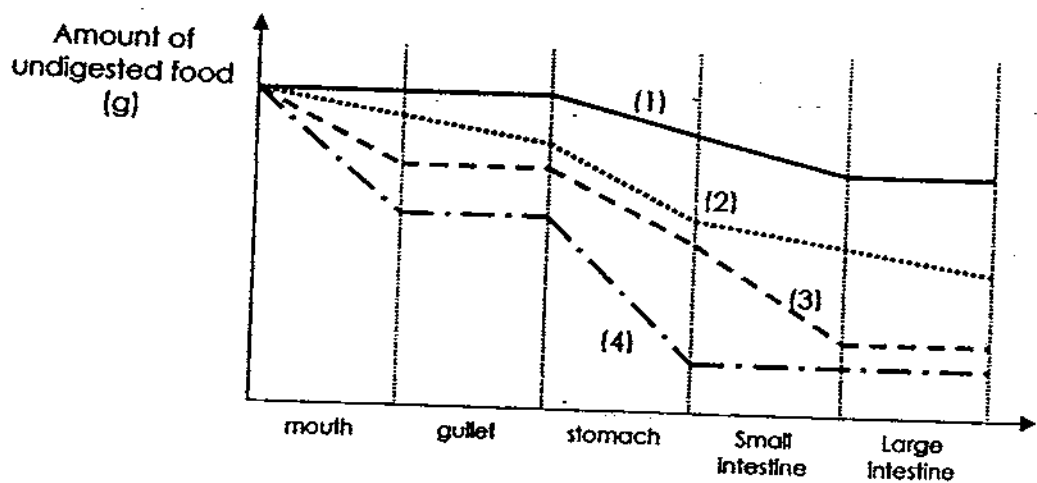

Which line correctly shows the relative amount of undigested food in the human digestive system?

17. When we breathe, air is inhaled (taken in) and exhaled (given out). Which of the following shows the difference between inhaled air and exhaled air?

Difference between	
Inhaled Air	Exhaled Air
1) Is warmer	Is cooler
2) Has more water vapour	Has less water vapour
3) Contains more oxygen	Contains less oxygen
4) Contains more carbon dioxide	Contains less carbon dioxide

18. What is the function of red blood cells?

- 1) Fight foreign bodies that enter the body.
- 2) Transport oxygen from the lungs to all parts of the body.
- 3) Transport digested food from the small intestine to all parts of the body.
- 4) Transport unwanted materials to special organs for removal from the body.

19. Study the diagram below.

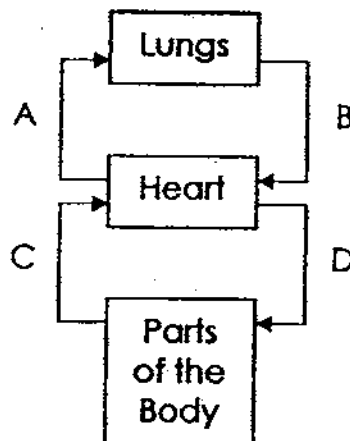

Which statements ~~is~~ about the circulatory system is ~~are~~ true?

- 1) Vessel A is an ~~an~~ <sup>vein</sup> artery.
- 2) Vessel B is a vein.
- 3) Vessel C contains blood rich in oxygen.
- 4) Vessel D contains blood rich in carbon dioxide.

20. Which of the following is/are (an) unicellular organism(s)?

- A) Yeast
- B) Zygote
- C) Nerve Cell
- D) Bacterium

- ~~1)~~ A and B only
- ~~2)~~ A and D only
- ~~3)~~ B and C only
- ~~4)~~ C and D only

21. Study the flowchart below.

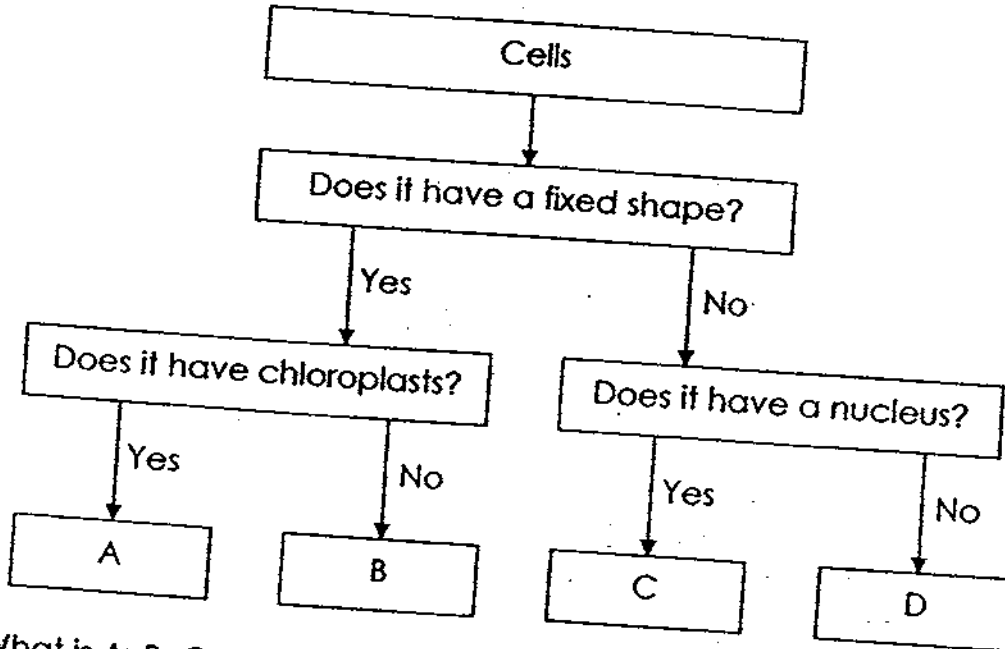

What is A, B, C and D?

	A	B	C	D
<del>1)</del>	Guard Cell	Onion Skin Cell	Cheek Cell	Red Blood Cell
<del>2)</del>	Leaf Cell	Root Cell	Sperm Cell	Egg Cell
<del>3)</del>	Onion Skin Cell	Leaf Cell	Red Blood Cell	Sperm Cell
<del>4)</del>	Root Cell	Guard Cell	Egg Cell	Cheek Cell

22. Which of the following is true about the parts of a cell?

- 1) The cell wall covers and protects only the nucleus.
- 2) The cytoplasm controls when the cell performs photosynthesis.
- 3) The chloroplast is a jelly-like fluid which contains other cell parts.
- 4) The cell membrane acts as a filter only allowing certain substances to pass through.

23. Study the circuit diagram below.

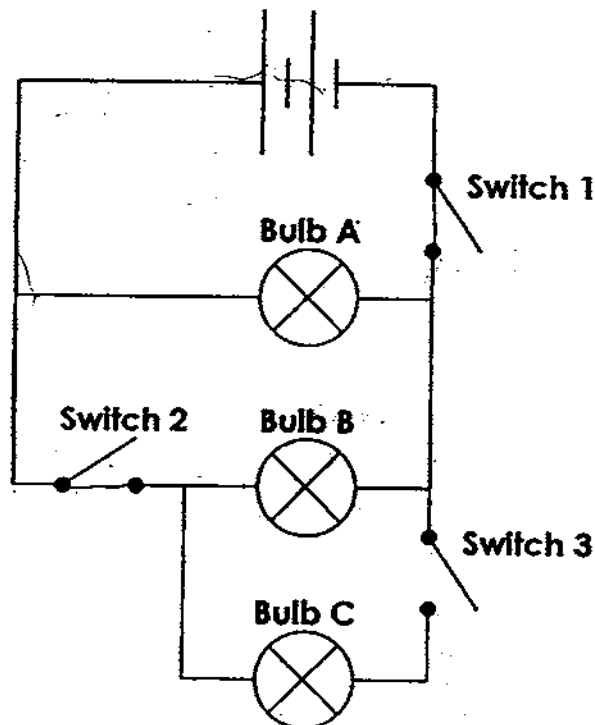

Identify the correct operation of the switches and light bulbs.

	Switch 1	Switch 2	Switch 3	Bulb A	Bulb B	Bulb C
1)	Open	Closed	Closed	Does not light up	Lights up	Lights up
2)	Closed	Open	Closed	Does not light up	Lights up	Lights up
3)	Closed	Closed	Open	Lights up	Lights up	Does not light up
4)	Open	Open	Open	Lights up	Lights up	Lights up

24. A circuit diagram with 2 identical bulbs, 2 batteries and a switch is shown below. Bulb A and Bulb B light up when the switch is closed. Both bulbs light up with equal brightness.

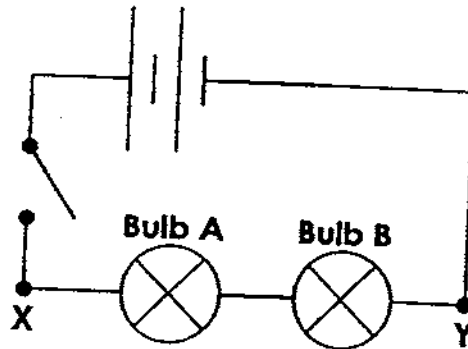

Bulb C is then connected to the circuit at X and Y.

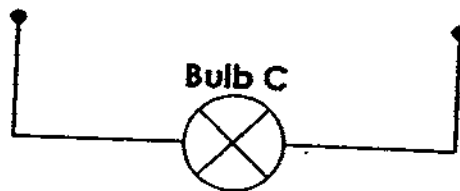



What will happen to Bulb A?

- 1) It will not light up.
- 2) It will become brighter than before.
- 3) It will become dimmer than before.
- 4) It will light up with the same brightness.

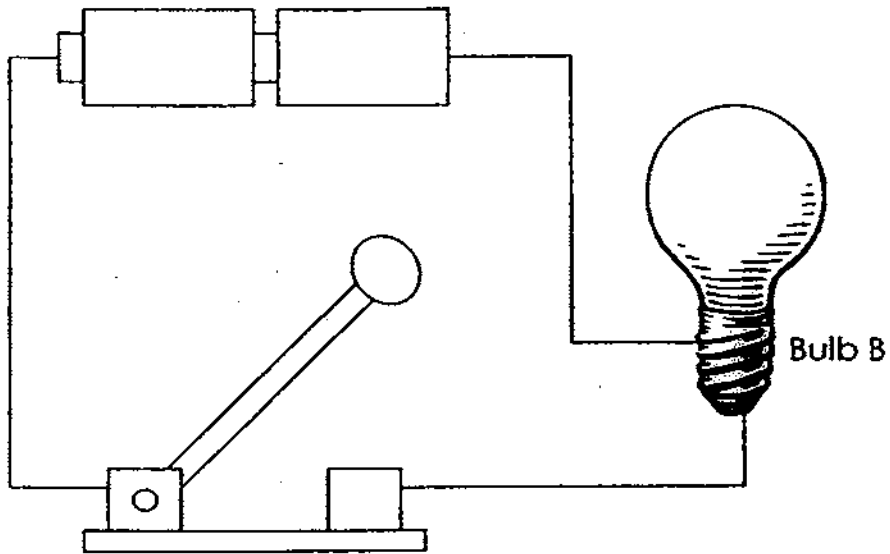
25. Study the circuit below.

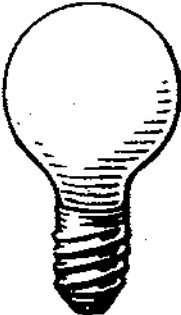

Bulb B lights up when the switch is closed. What will happen to the brightness of Bulb B when the switch is replaced with a bulb, then a battery and finally a coin? Assume that all connections are correctly in place.

Bulb	Battery	Coin
		
remains the same	remains the same	remains the same
dimmer	brighter	remains the same
dimmer	brighter	does not light up
remains the same	remains the same	dimmer

26. Adam made a circuit card with 6 paper clips and a length of copper wire. He connected the circuit card to a battery and a bulb as shown below.

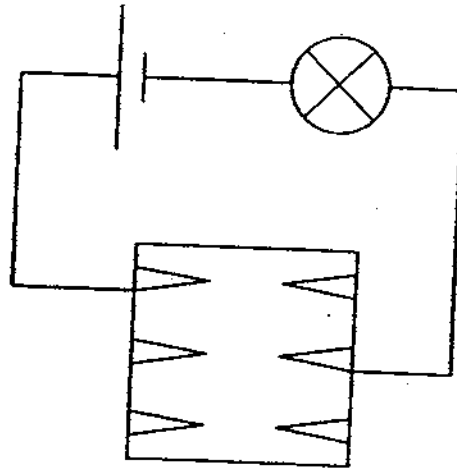

Circuit Card

If the bulb lights up, which of the following cards shows the connection of the paper clips?

1)

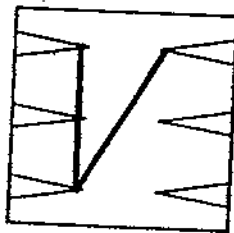

2)

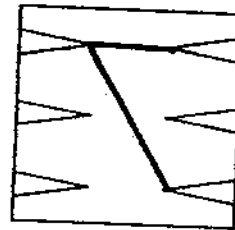

3)

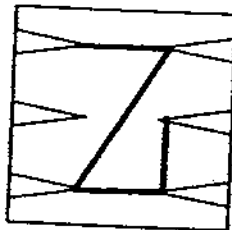

4)

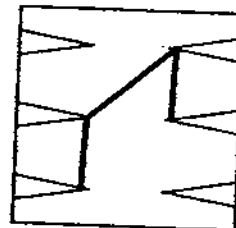

27. 5 bar magnets are arranged as shown below. The ends of the magnets have been labelled A to J.

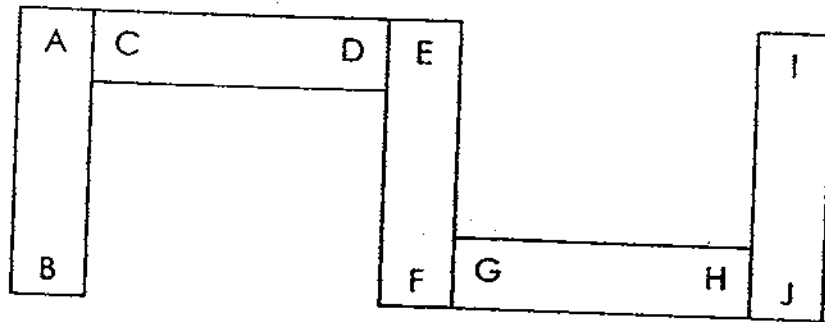

Which of the following shows another possible arrangement of the magnets?

1)

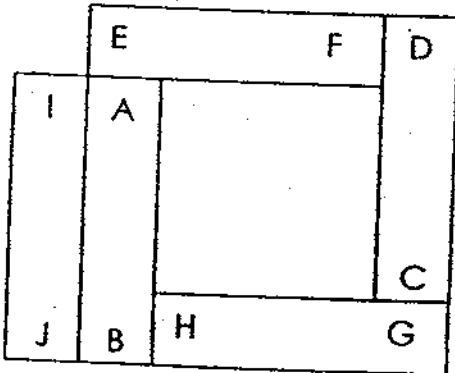

2)

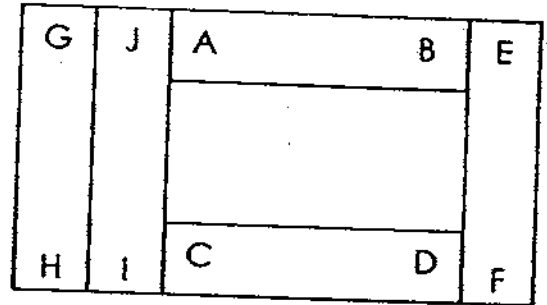

3)

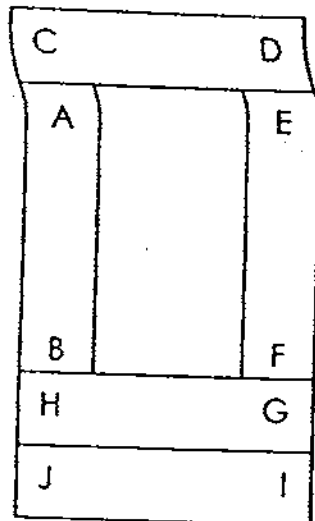

4)

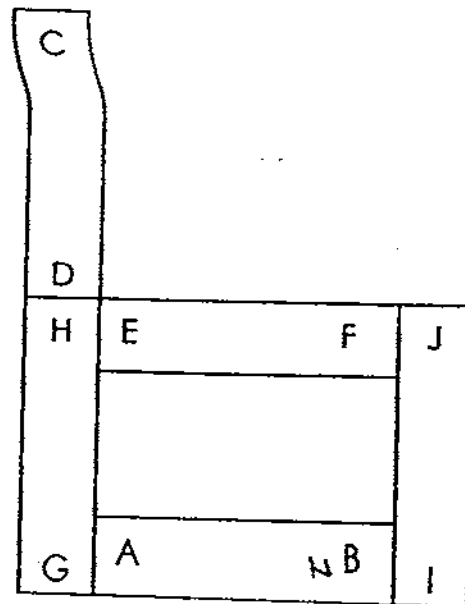



28. A thermometer was left in a beaker of ice as shown below. The beaker of ice was left on a table at room temperature for 10 hours.

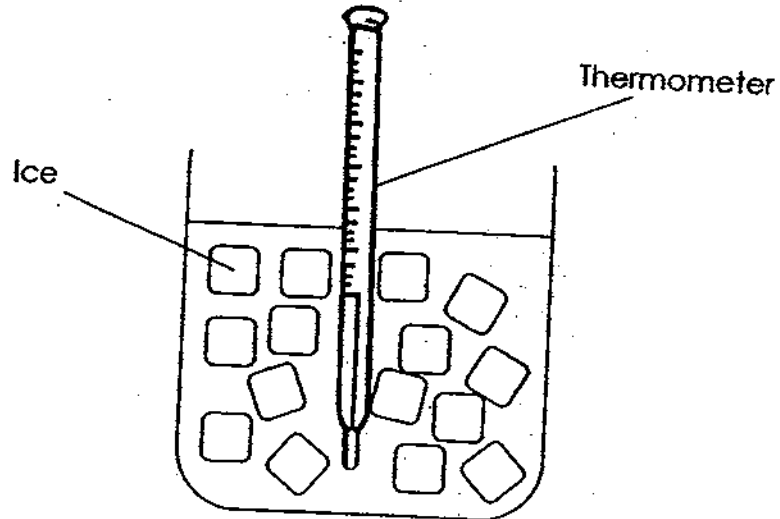

Which graph shows the change in temperature of the ice over time?

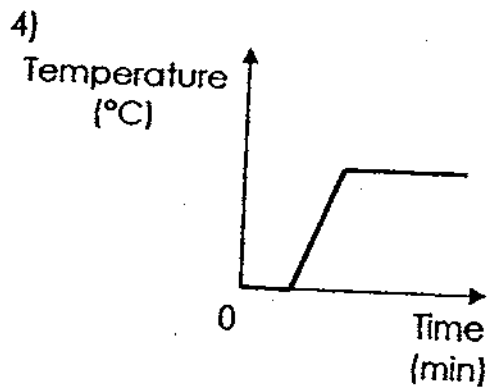
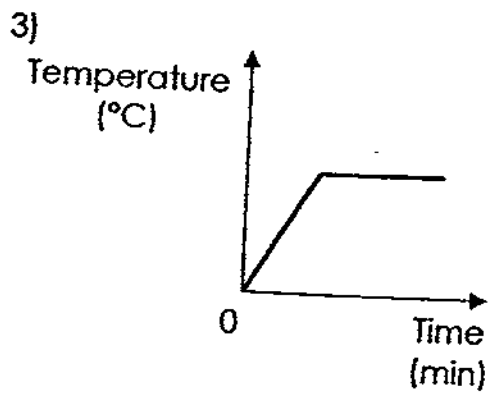
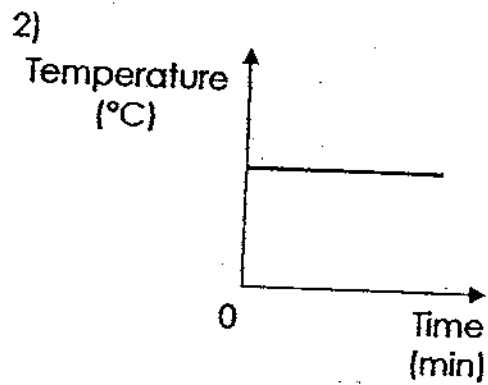
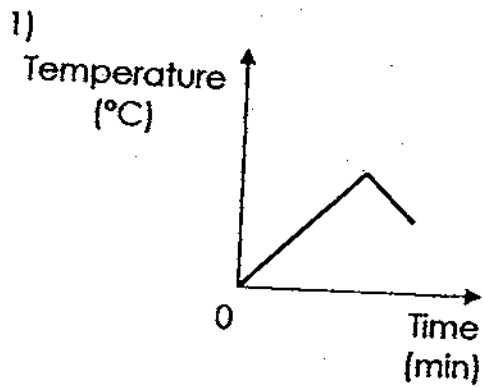

29. Look at the diagram below.

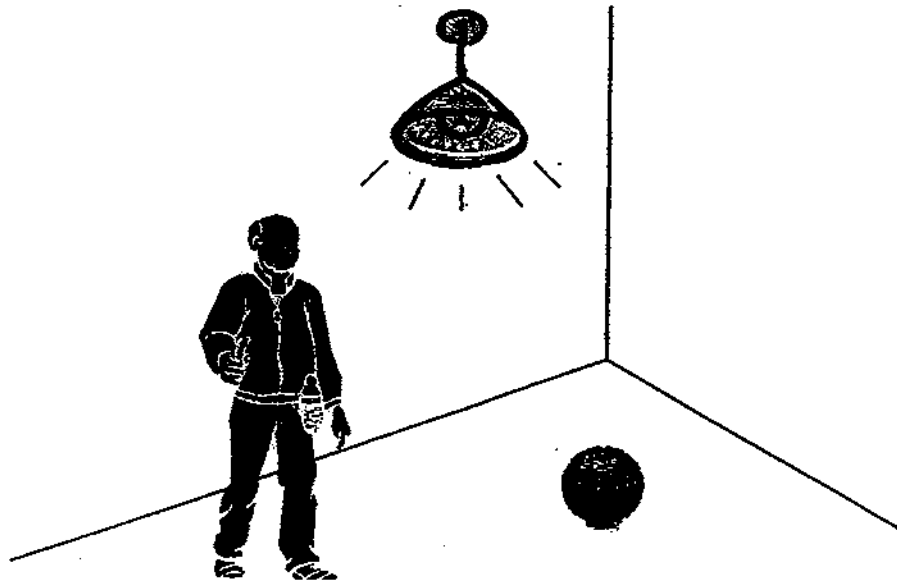

Why is Jack able to see the ball?

- 1) The ball gives off light which is reflected into Jack's eyes.
- 2) Jack's eyes give off light which reflects off the ball and into Jack's eyes.
- 3) Light from the surroundings is reflected off the ball and into Jack's eyes.
- 4) Light from the surroundings is reflected off Jack's eyes and onto the ball.

30. Which of the following actions requires energy?

- A) Sleeping
- B) Standing still
- C) Running on a track
- D) Watching a television programme

- 1) C only
- 2) C and D only
- 3) B, C and D only
- 4) A, B, C and D

--- End of Booklet A ---

**TAO NAN SCHOOL**

**PRIMARY 5 SCIENCE END-OF-YEAR EXAMINATION – 2009**

Name: \_\_\_\_\_ ( ) Date: 29 October 2009

Class: P5 \_\_\_\_\_

Duration: 1h 45min

**BOOKLET B**

**INSTRUCTIONS TO CANDIDATES**

**Do not open this booklet until you are told to do so.**

**Follow all instructions carefully.**

**Answer all questions.**

	Score	Marks
Section B		40

**Section B (40 marks)**

For the questions, 31 to 46, write your answers in the spaces provided.

31. Classify the following actions according to how they help to conserve water, by writing the letters, A, B, C, D, E and F, which represent them in the table below. (3 marks)

Letter	Action
A	Taking a shorter shower.
B	Collecting rainwater to water plants.
C	Washing clothes only when there is a full load.
D	Using waste water from the washing machine to mop the floor.
E	Using a pail to wash the car instead of using a running hose.
F	Turning waste water into clean water for human consumption.

**Water Conservation**

Water Conservation		
Reduce	Reuse	Recycle

32. Greg wanted to investigate the effects of overcrowding in plants. He planted seeds of the same type in 4 identical pots. He recorded the number of seeds planted and the average height of the seedlings after 1 week in the table below.

	Number of seeds planted	Average height of seedlings after 1 week (cm)
Pot A	2	2
Pot B	8	3
Pot C	14	5
Pot D	20	8

- a. How does the number of seeds planted affect the average height of the seedlings? (1 mark)
- 
- b. Explain your answer in (a). (1 mark)
- 
- c. What factors must be present for a seed to germinate? (1 mark)
-

33. The picture below shows a developing human baby.

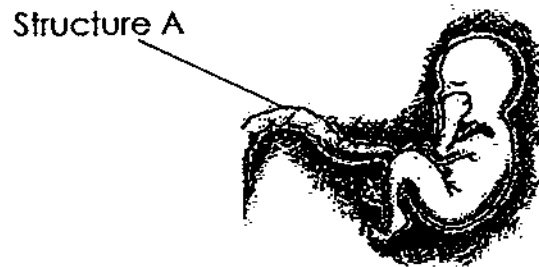

a. Identify Structure A. (1 mark)

---

b. What is the function of Structure A? (1 mark)

---

---

c. The time taken for a human baby to develop fully until it is ready to be born is called the gestation period. How long is the gestation period of the human baby? (1 mark)

---

---

34. A white rose is placed in a bottle of blue dye as shown below.

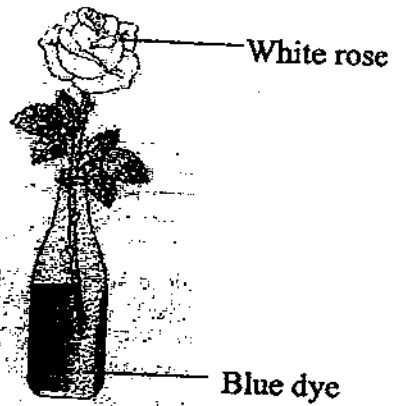

a. After 24 hours, what can be observed about the colour of the rose? (1 mark)

---

b. Explain your answer in (a). (1 mark)

---

35. The diagram below shows a plant cell.

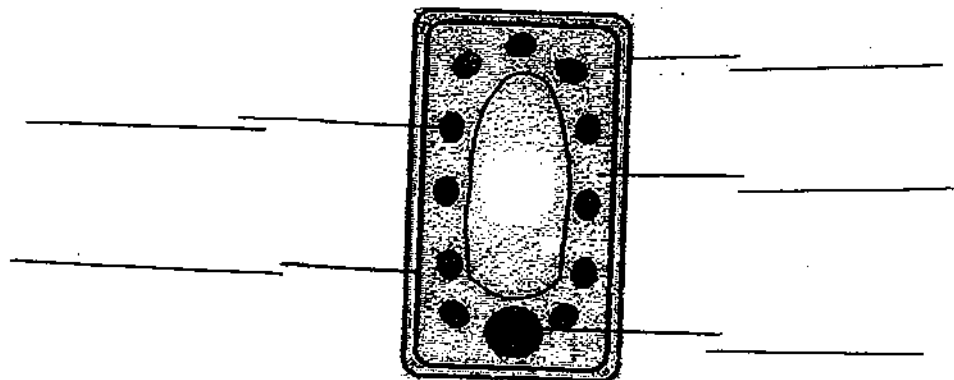

a. Label the following parts on the diagram. (2 marks)

- Cytoplasm
- Cell membrane
- Nucleus
- Chloroplast

b. Label the part that helps the cell to maintain its regular shape. (1 mark)

36. The picture below shows the magnified cross-section of the surface of a leaf.

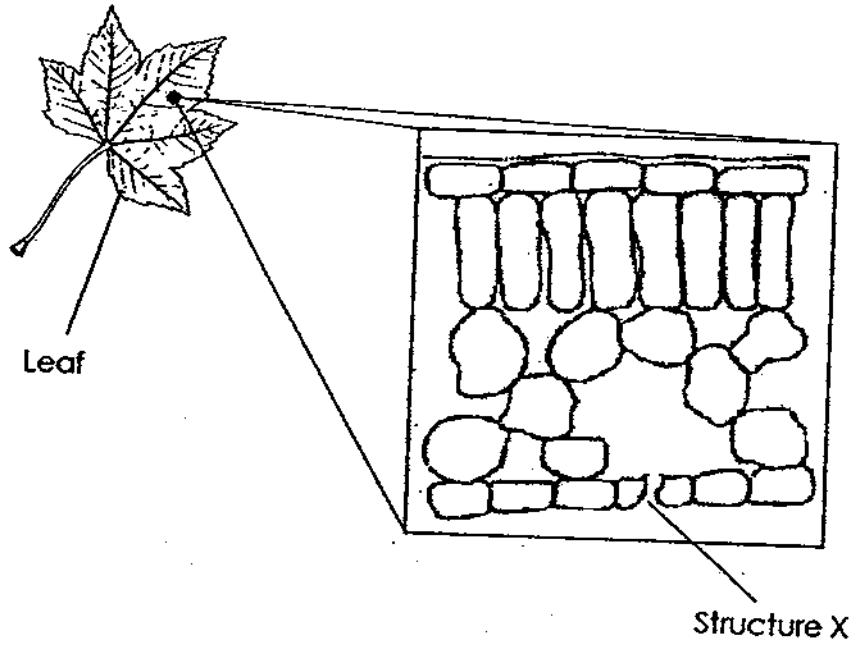

- a. Identify Structure X? (1 mark)

---

- b. What is the function of Structure X? (1 mark)

---



37. Dennis connected a circuit as shown below.

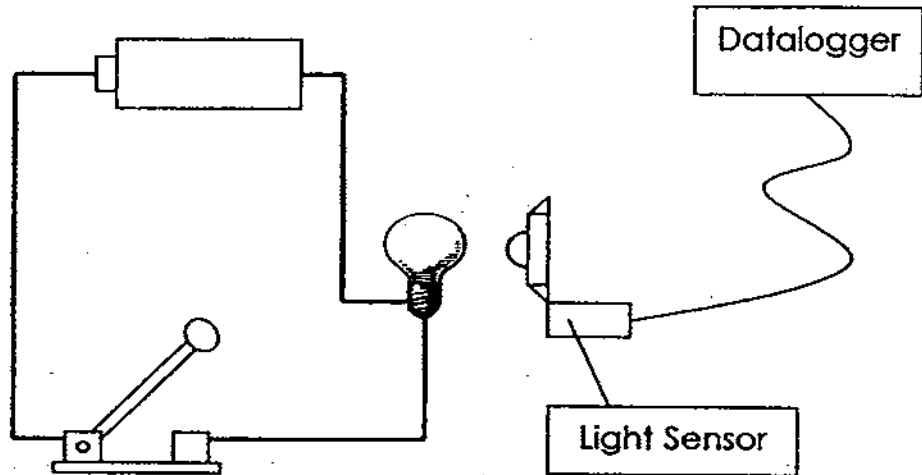

When the switch is closed, Dennis measured the brightness of the bulb with the light sensor and datalogger. Then he added batteries to the circuit one at a time and measured the brightness of the bulb. His measurements are recorded in the table below.

Number of batteries	Brightness of the bulb (lux)
1	70
2	125
3	160
4	230
5	0

a. What is the brightness of the bulb when 5 batteries were used? (1 mark)

b. Explain your answer in (a). (1 mark)

38. Draw a circuit diagram that include:

- 2 batteries
- 1 switch
- 2 bulbs, labelled **A** and **B**

The circuit diagram must show the following:

- Bulb A is lit all the time
- Bulb B is lit when the switch is closed
- Bulb B is not lit when the switch is open

(2 marks)

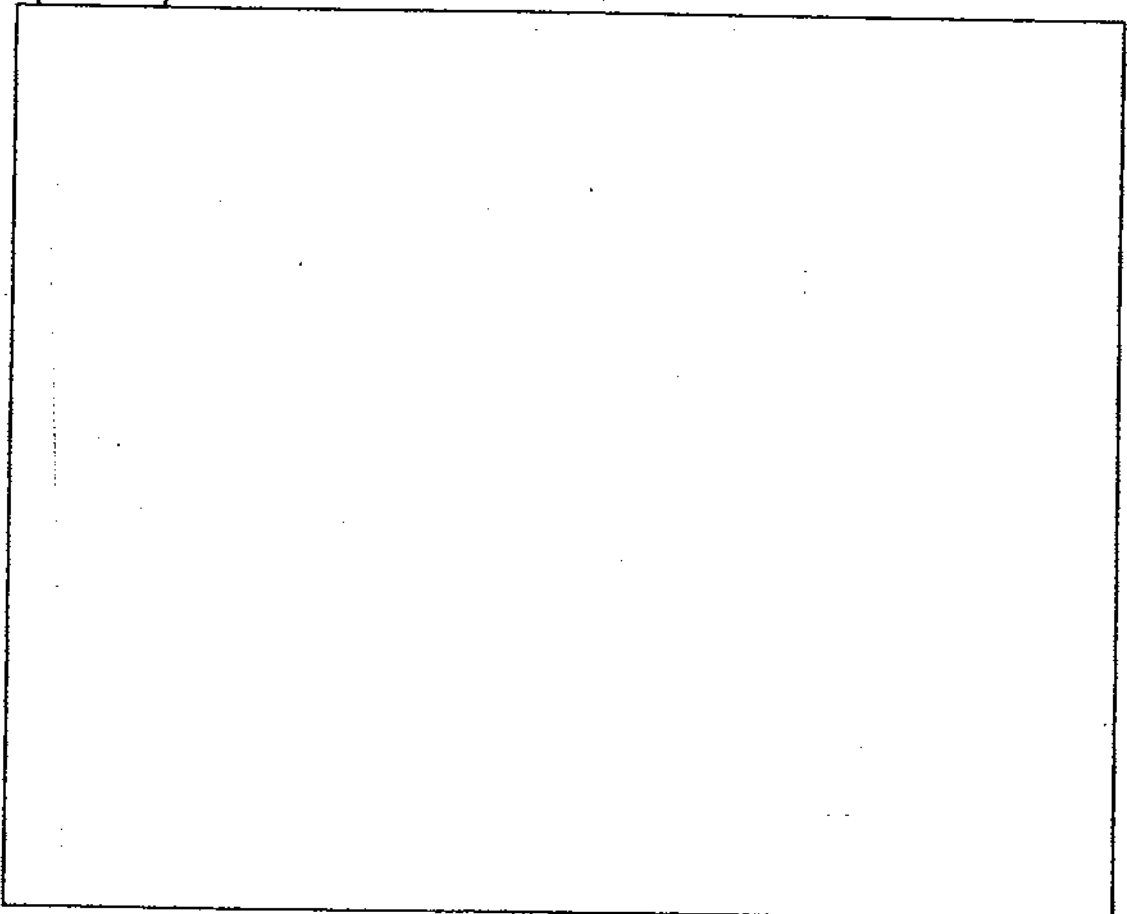

39. The picture below shows an electrical transmission tower.



An electrical transmission tower is used to support electrical cables. Whenever the tower needs to be repaired, the repairman has to wear special gloves and boots before doing any repairs.

- a. Why does the repairman have to wear the special gloves and boots? (1 mark)
- 
- b. What property must the material for making the gloves and boots have? (1 mark)
- 
- c. Give an example of a suitable material to make the gloves and boots? (1 mark)
-

40. Currently, power stations in Singapore burn fossil fuels to produce electricity. To minimise usage of fossil fuels in producing electricity, the power stations also burn garbage.

a. What is an advantage of burning garbage to produce electricity? (1 mark)

---

b. Instead of burning fossil fuels or garbage to produce electricity, suggest 1 alternative renewable source of energy to produce electricity. (1 mark)

---

41. Information about 4 organisms are given below.

A is the prey of D.

A eats C.

B is the predator of D.

C is a food producer.

a. Using the information given, construct a food chain showing the food relationship between the 4 organisms. (1 mark)

b. Which organism, A, B, C or D, is both prey and predator? (1 mark)

---

42. In the diagram below, the driver in car A was able to see the approaching car B from the mirror when he was rounding the bend along the road.

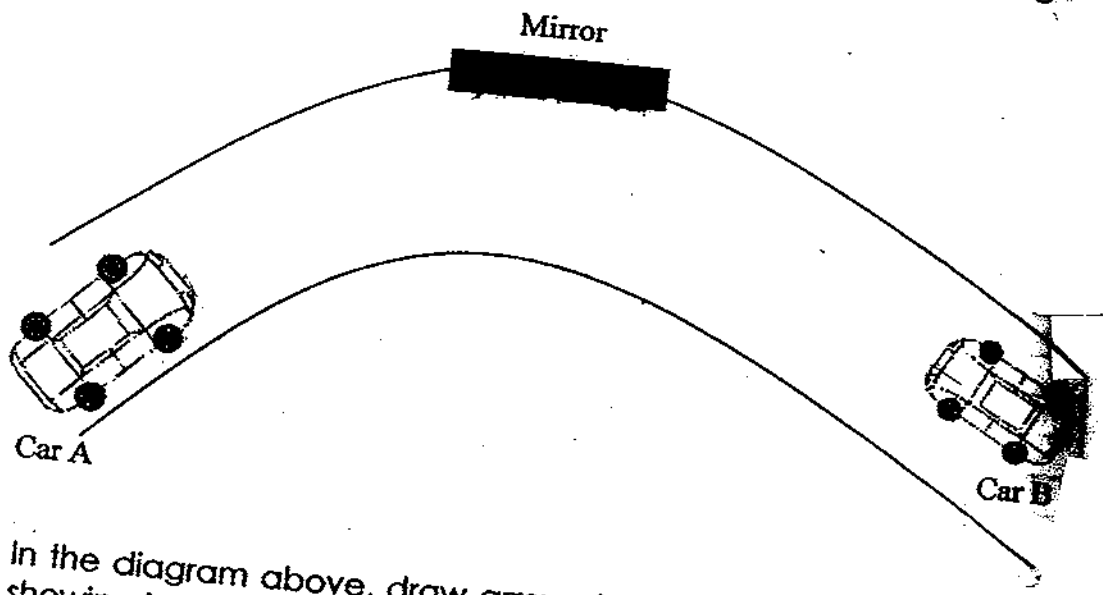

- a. In the diagram above, draw arrows to represent the path of light showing how the driver in Car A is able to see Car B. (1 mark)
- b. What is the property of light that enabled the driver in car A to see the approaching Car B. (1 mark)

48a Use the following Helping Words to complete the concept map below. (2 marks)

Helping Words			
Carbon dioxide	Oxygen	Glucose	Water

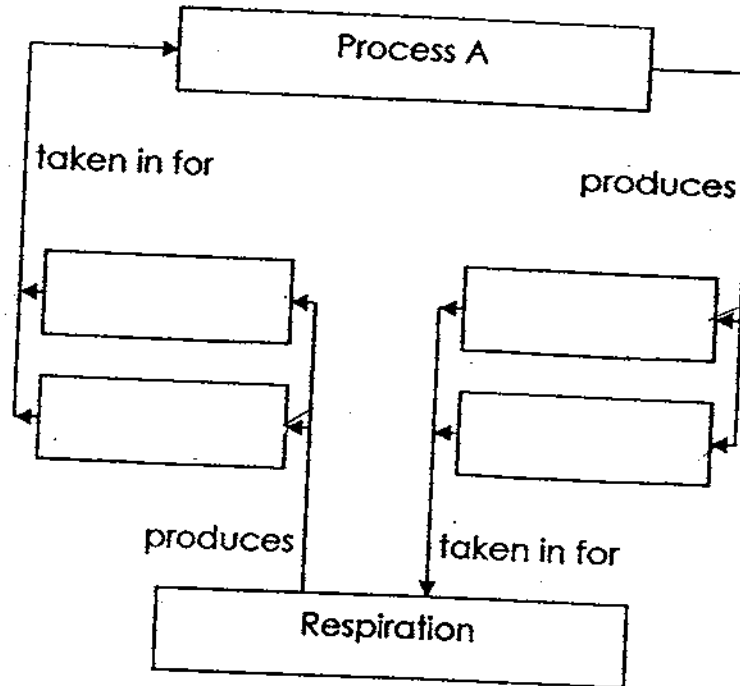

b. What is Process A? (1 mark)

---

c. Why is Process A important to plants? (1 mark)

---



---



---

44. Edison shone a fixed amount of light on a plant for an hour and measured the amount of oxygen produced. He repeated the experiment using different amounts of light and recorded his results in the table below.

Amount of light (lux)	Amount of oxygen produced (cm <sup>3</sup> )
500	1
1000	4
2000	5
3000	6
4000	7
5000	8
6000	8
7000	8

- a. Based on Edison's readings, what conclusion can he make about the amount of light and the amount of oxygen produced? (1 mark)
- 
- 
- b. What is the least amount of light that will produce the most amount of oxygen? (1 mark)
- 
- c. What should Edison do to ensure the reliability of the results of his experiment? (1 mark)
-

45. A solar heater water tank is placed on top of a house as shown below.

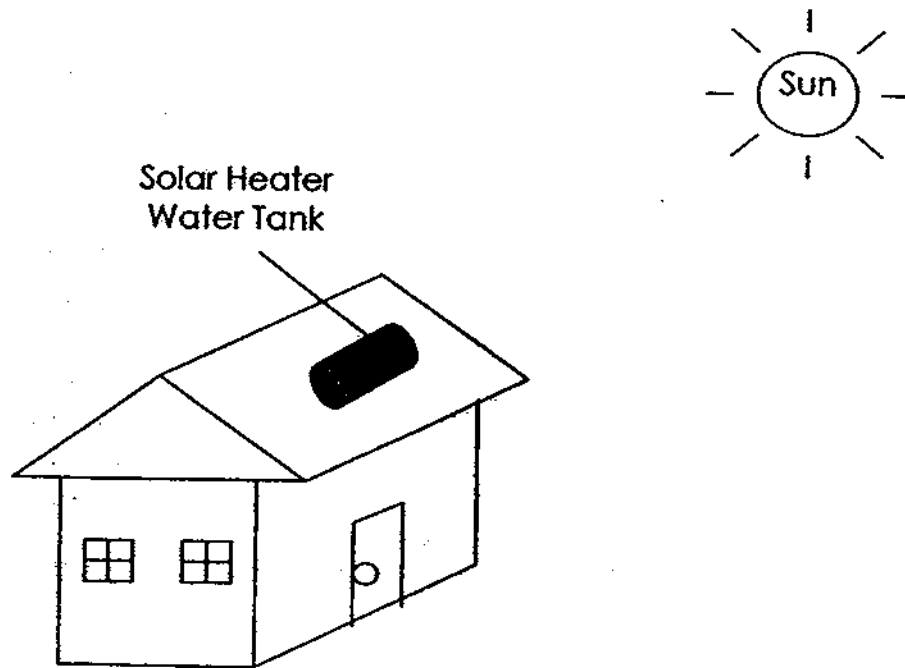

- a. Why is the solar heater water tank placed on top of the house?  
(1 mark)
- 

- b. What is an advantage of using the solar heater water tank?  
(1 mark)
-



46. Tom provided 3 types of food for Animal X and recorded Animal X's reaction to the 3 types of food over a period of 7 days.

Type of Food	Animal X's reaction
Food A	Did not eat the food at all
Food B	Ate the food
Food C	Did not eat the food at all

- a. What food test can Tom perform on the 3 types of food to find out if they are from plants or animals? (1 mark)
- 

- b. If Animal X is a plant eater, what would be the results of the food test on Food B? (1 mark)
- 

--- End of Booklet B ---



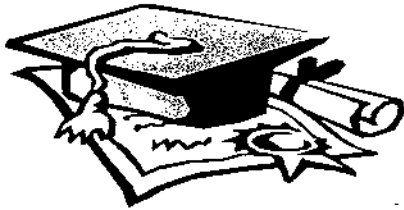

# ANSWER SHEET

**EXAM PAPER 2009**

**SCHOOL : TAO NAN PRIMARY**  
**SUBJECT : PRIMARY 5 SCIENCE**

**TERM : SA2**

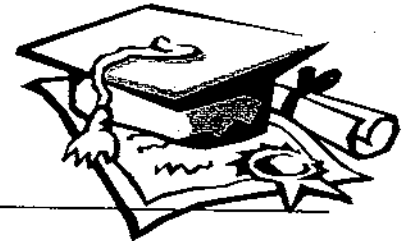

Q1	Q2	Q3	Q4	Q5	Q6	Q7	Q8	Q9	Q10	Q11	Q12	Q13	Q14	Q15	Q16	Q17
3	2	1	4	2	3	4	2	1	1	3	4	2	1	3	3	3

Q18	Q19	Q20	Q21	Q22	Q23	Q24	Q25	Q26	Q27	Q28	Q29	Q30
2	1	2	1	4	3	3	2	3	3	4	3	4

31) Reduce: A, C, E      Reuse: D, B      Recycle: F

32)a) As the number of seeds planted increases, the average height of the seedling also increases.

- b) If the plants are overcrowded, they will grow taller to fight for sunlight.
- c) Warmth, moist and oxygen.

33)a) Umbilical cord.

- b) It transports the nutrients from the digested food and water the mother eats and oxygen into the baby through the umbilical cord.
- c) Nine months.

34)a) The white rose turns blue.

- b) The blue dye is transported to the white rose through the xylem tube.

35)

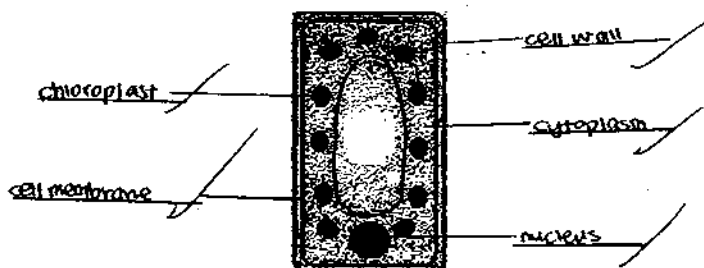

36)a)Stomata.

b)It allows the exchange of gases to take place.

37)a)0 lux.

b)The voltage of 5 batteries was too high so the bulb fused.

38)

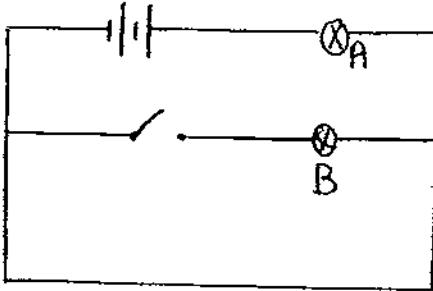

39)a)It is to prevent the repairman from being electrocuted.

b)It must be an insulator of electricity.

c)Rubber.

40)a)It reduces the amount of garbage to be disposed.

b)Solar energy.

41)a)C→A→D→B

b)D.

42)a)

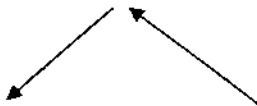

b)Light can be reflected.

43)a)water

Oxygen

Carbon dioxide

Glucose

b)Photosynthesis.

c)It enables the plant to make food and survive.

44)a)The more the amount of light, the more oxygen is produced until it reaches a maximum of 8cm<sup>3</sup> for any amount of light greater than 5000 lux.

b)5000 lux.

c)He should repeat the experiment using another plant of the same type.

45)a)It is easier for the solar panel to absorb heat from the sun.

b)It saves electricity.

**46)a)Add iodine to the food. If it turns dark blue, it means starch is present and the food is from plants. If the food is from animals, the iodine remain unchanged.**

**b)The iodine will turn dark blue.**