



HENRY PARK PRIMARY SCHOOL
SECOND SEMESTRAL ASSESSMENT 2019

PRIMARY 5

SCIENCE

BOOKLET A (56 MARKS)

INSTRUCTIONS TO CANDIDATES

1. Do not turn over this page until you are told to do so.
2. Follow all instructions carefully.
3. Answer all questions.
4. Shade your answers on the Optical Answer Sheet (OAS) provided.

Name: _____ ()

Class: Primary 5 ()

Date: 22 October 2019

Total Time: 1 h 45 min

Booklet	Marks
A	/ 56
B	/ 44
Total (A+B)	/ 100

Parent's Signature: _____

www.testpapersfree.com

Section A (56 marks)

For each question from 1 to 28, four options are given. One of them is the correct answer.
Make your choice and shade the correct oval (1, 2, 3, or 4) on the Optional Answer Sheet.

1. The diagrams below show animals A, B and C.

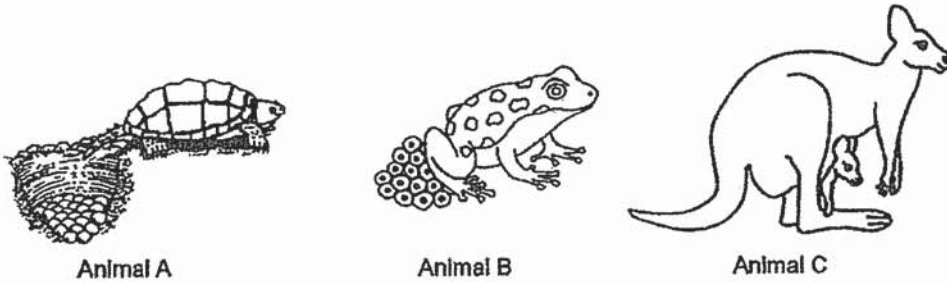

The flowchart shows how the three animals are grouped.

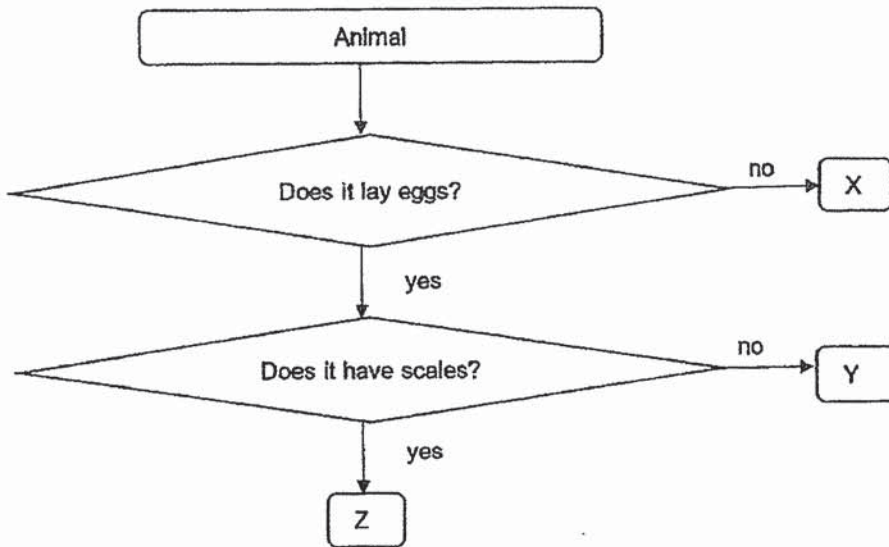

Based on the information given, which of the following correctly puts animals, A, B and C into groups X, Y and Z?

	X	Y	Z
(1)	B	A	C
(2)	C	A	B
(3)	C	B	A
(4)	B	C	A

2. Which of the following statements is / are correct of a beetle and a grasshopper?

- A Their young live on land.
- B Their young do not have wings.
- C They have 3 stages in their life cycles.

- (1) C only
- (2) A and B only
- (3) B and C only
- (4) A, B and C

3. Study the three different cells shown in the diagrams below.



Which one of the following statements is correct about the three cells?

- (1) They can make food.
- (2) They are animal cells.
- (3) They have nucleus and cell wall.
- (4) They have cytoplasm and cell membrane.

4. The diagrams below show a flowering plant and a cell taken from it.

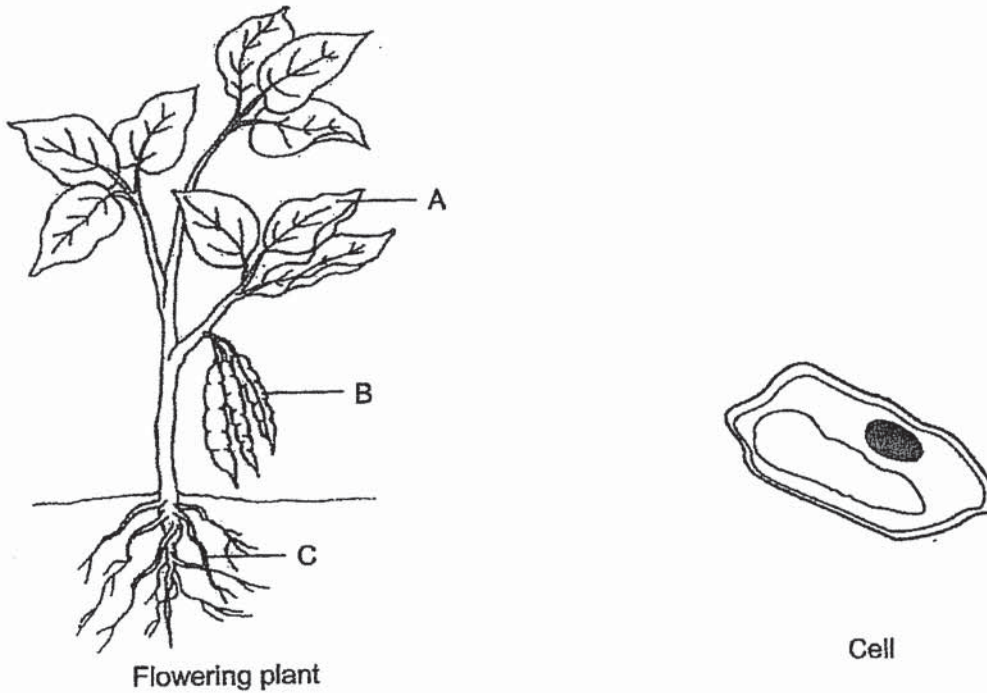

In which part(s) of the plant are you likely to find the cell?

- (1) B only
- (2) C only
- (3) A and B only
- (4) B and C only

5. Study the diagram of a flower below.

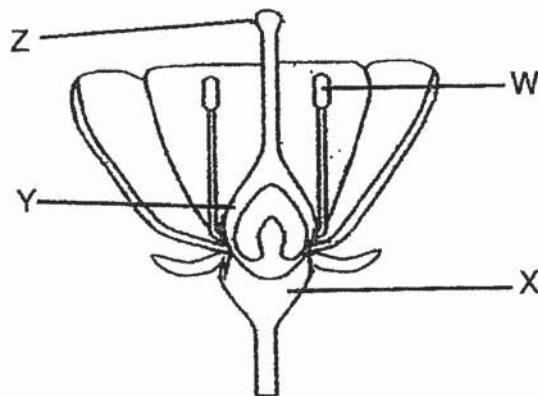

Which part of the flower, W, X, Y or Z, will develop into a fruit after fertilization?

- (1) W
- (2) X
- (3) Y
- (4) Z

6. Seed dispersal prevents overcrowding and reduce competition between young plants and parent plants.

Which of the following are the substance(s) and / or condition(s) they compete for?

- A air
- B light
- C food
- D space
- E water

- (1) A, C and D
- (2) B, D and E
- (3) B, C, D and E
- (4) A, B, C, D and E

7. The diagram below shows parts of the female human reproductive system.

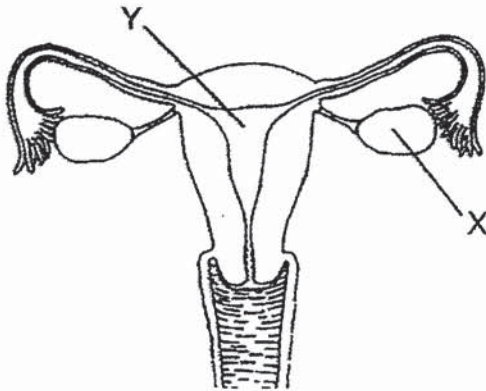

Which one of the following statements is correct of the system shown above?

- (1) A sperm is released from X.
- (2) A fertilised egg is released from X.
- (3) A fertilised egg is released from Y.
- (4) A fertilised egg develops and grows in Y.

8. Jane has the following characteristics :

- A long nails
- B fair complexion
- C attached earlobes
- D unable to roll tongue

Which of the characteristics could Jane have inherited from her parents?

- (1) A and B only
- (2) B and D only
- (3) A, C and D only
- (4) B, C and D only

9. The diagram shows the human digestive system.

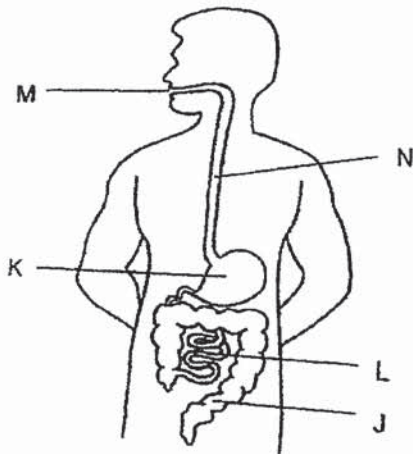

Which of the following correctly identifies the organs involved in the processes?

	Organ(s) involved in digestion of food	Organ(s) involved in passing digested food to the bloodstream
(1)	M, K, L	L
(2)	M, K	L, J
(3)	K, L, J	M, K, L
(4)	L, J	N

10. The diagram below shows how food and water are transported to and from different parts of the plant.

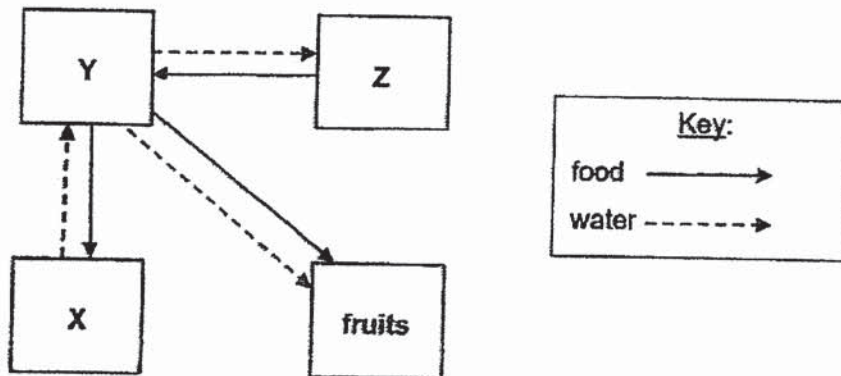

Which of the following correctly identifies parts X, Y and Z?

	X	Y	Z
(1)	leaves	stem	roots
(2)	leaves	roots	stem
(3)	roots	stem	leaves
(4)	roots	leaves	stem

11. In which of the following plant parts can the water-carrying tubes be found?

- A stem
- B roots
- C leaves

- (1) A and B only
- (2) B and C only
- (3) A and C only
- (4) A, B and C

12. Kassim put a plant in a beaker of blue-coloured water. After one day, he cut the stem. A section of the stem is shown below.

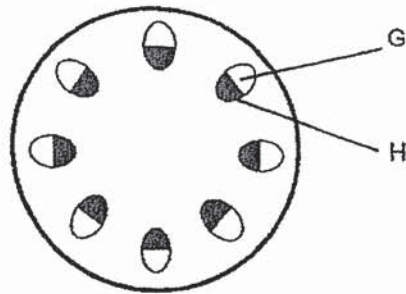

Kassim observed that the tube H turned blue but not tube G. Why?

- (1) Tube H transports food from the leaves to the stem.
 - (2) Tube H transports water from the roots to all parts of the plant.
 - (3) Tube H transports food from the leaves to all parts of the plant.
 - (4) Tube H transports water from the leaves to all parts of the plant.
13. Four blood samples, M, N, O and P, were taken from different blood vessels in a body. The graph below shows the amounts of carbon dioxide in each of these blood samples.

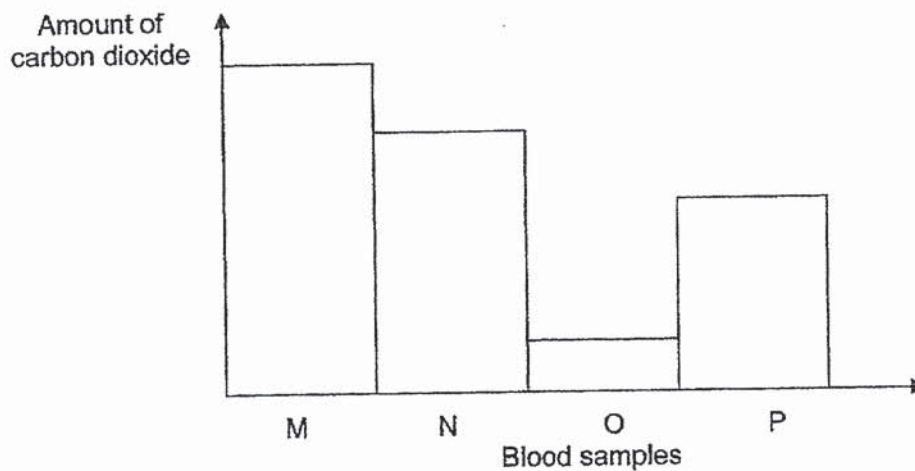

Which blood samples were most likely taken from the following blood vessels?

blood vessels carrying blood from	
lungs to heart	heart to lungs
(1) O	M
(2) M	O
(3) N	P
(4) P	O

14. One night, Asif walked from point A to C, passing a lamp post at point B as shown in the diagram below.

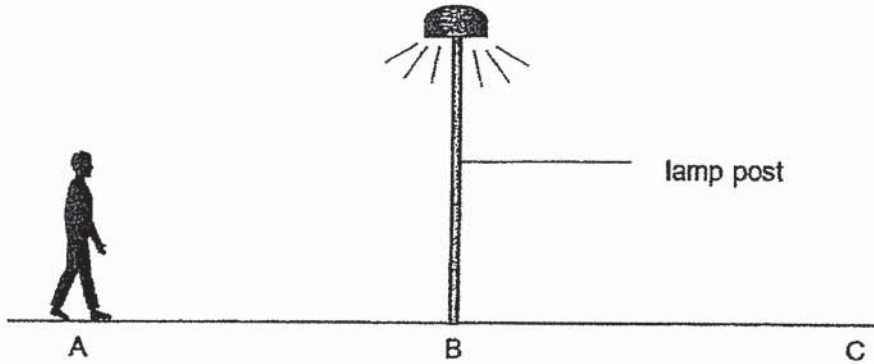

If the only light source nearby was the lamp post, which one of the graphs below shows how the length of his shadow changes from points A to C?

(1)

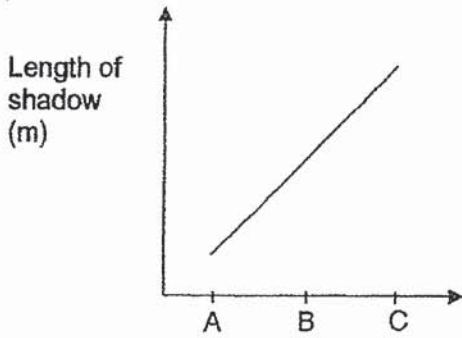

(2)

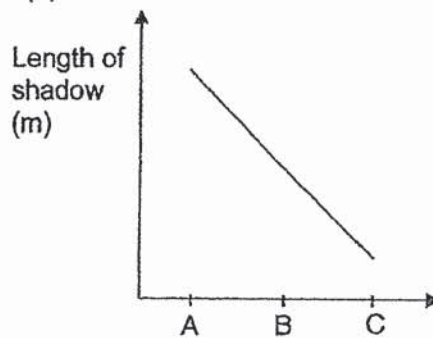

(3)

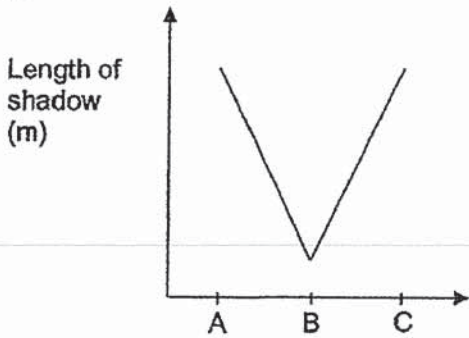

(4)

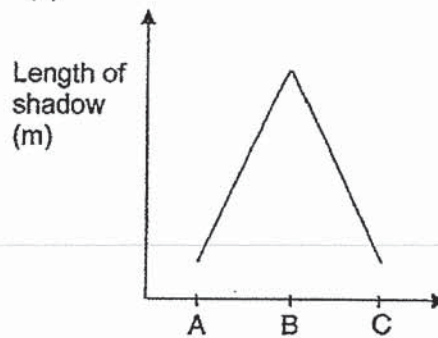

15. Alex had 4 shapes, each made of a different material, as shown below.

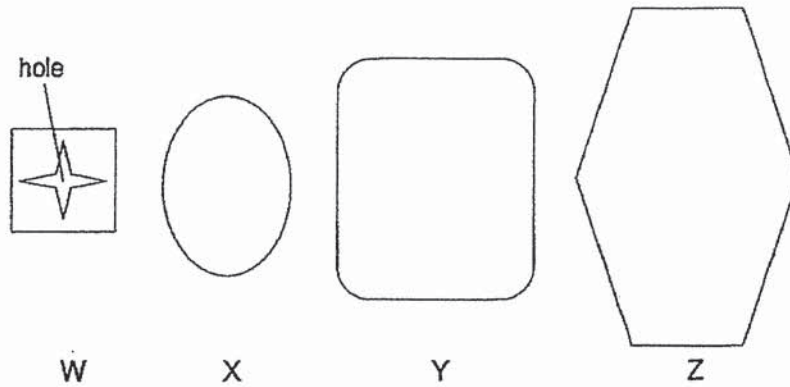

In a dark room, he placed all the cut-outs in front of a torch, as shown in the diagram below.

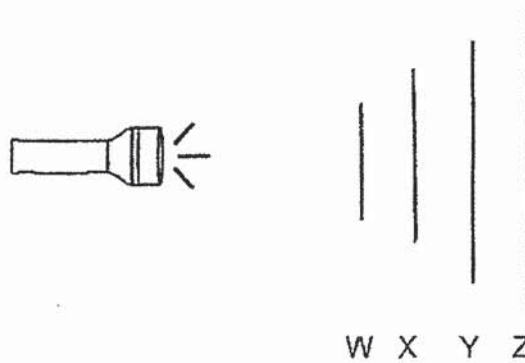

Alex switched on the torch and recorded his observation of the shadow formed on material Y as shown below. There was nothing seen on material Z.



observation of the shadow
formed on material Y

Based on Alex's observation, which of the following materials do not allow light to pass through?

- (1) W and X
- (2) W and Y
- (3) X and Y
- (4) Y and Z

16. Susan set up the experiment shown below. Both blocks are made up of 2 different materials, P and Q. Material Q is a poorer conductor of heat than material P.

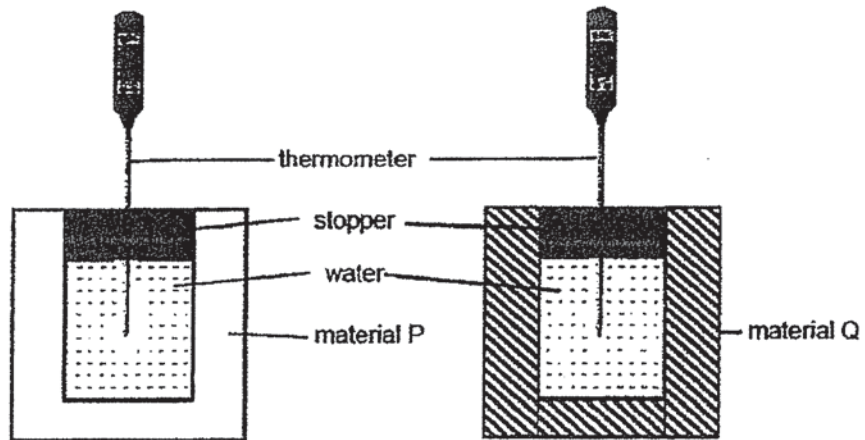

The temperature of water in both set-ups was 40°C at the start. She placed the set-ups in the refrigerator for 30 minutes at the same time.

Which of the following graphs correctly shows the temperature of the water in both set-ups throughout 30 minutes?

(1)

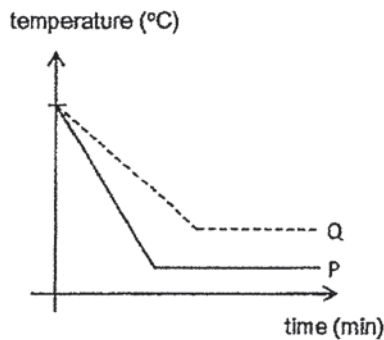

(2)

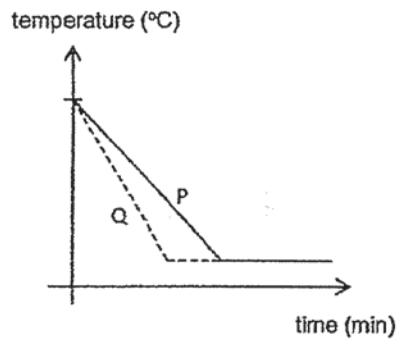

(3)

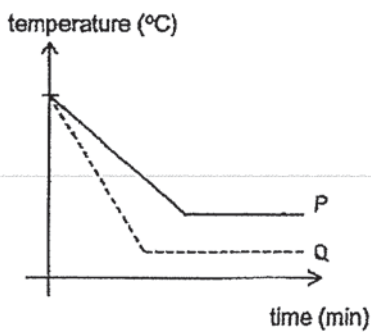

(4)

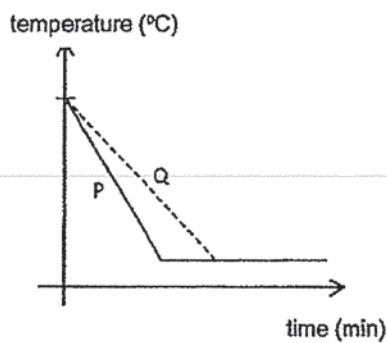

17. Adam used a bicycle pump to pump more air into a tyre as shown below. He observed that the size of the tyre remained the same.

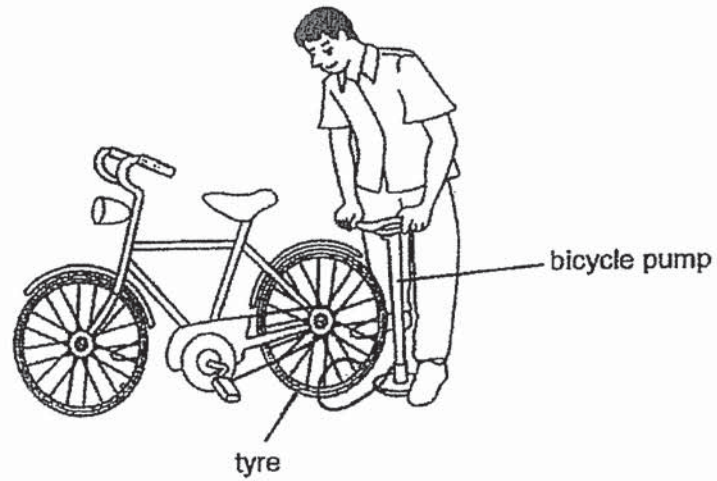

Which of the following explains his observation?

- (1) Air has mass.
- (2) Air takes up space.
- (3) Air has no definite volume.
- (4) Air cannot be compressed.

18. Small holes were made in the two similar cans, P and Q, shown in the diagrams below.

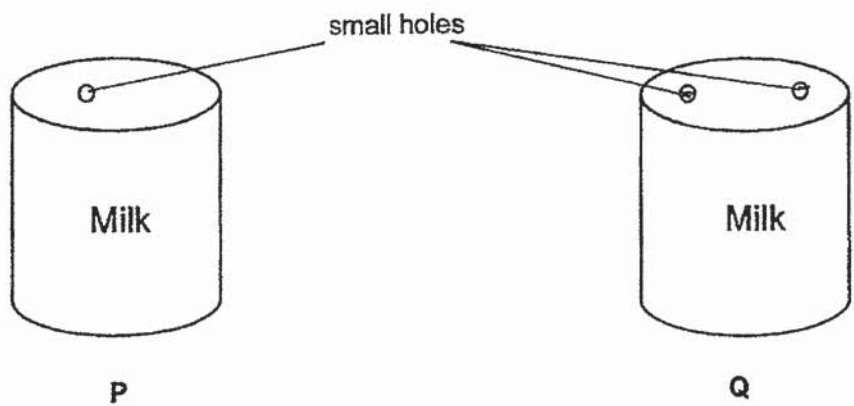

From which can would milk flow out faster, and why?

	Can	Reason
(1)	P	Air pushes the milk out.
(2)	P	Milk flows out from one hole only.
(3)	Q	Air enters through both holes and milk flows out from both holes.
(4)	Q	Air enters through one hole and milk flows out from the other hole.

19. The diagram below shows the change of state of water.

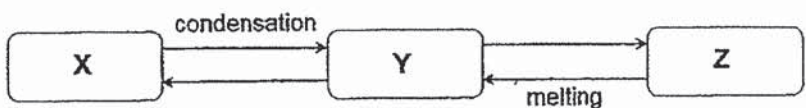

What are the states of water in X, Y and Z?

	X	Y	Z
(1)	solid	liquid	gas
(2)	solid	gas	liquid
(3)	gas	liquid	solid
(4)	gas	solid	liquid

20. The table below shows the melting and boiling points of substances, X and Y.

Substance	Melting point (°C)	Boiling point (°C)
X	45	60
Y	60	70

Which of the following statements is correct about substances X and Y?

- (1) Both substances boil at 60°C.
- (2) Both substances are solid at 25°C.
- (3) At 55°C, both substances are in the liquid state.
- (4) At 60°C, both substances are in the gaseous state.

21. The diagram below shows some human activities that have negative impacts on the environment.

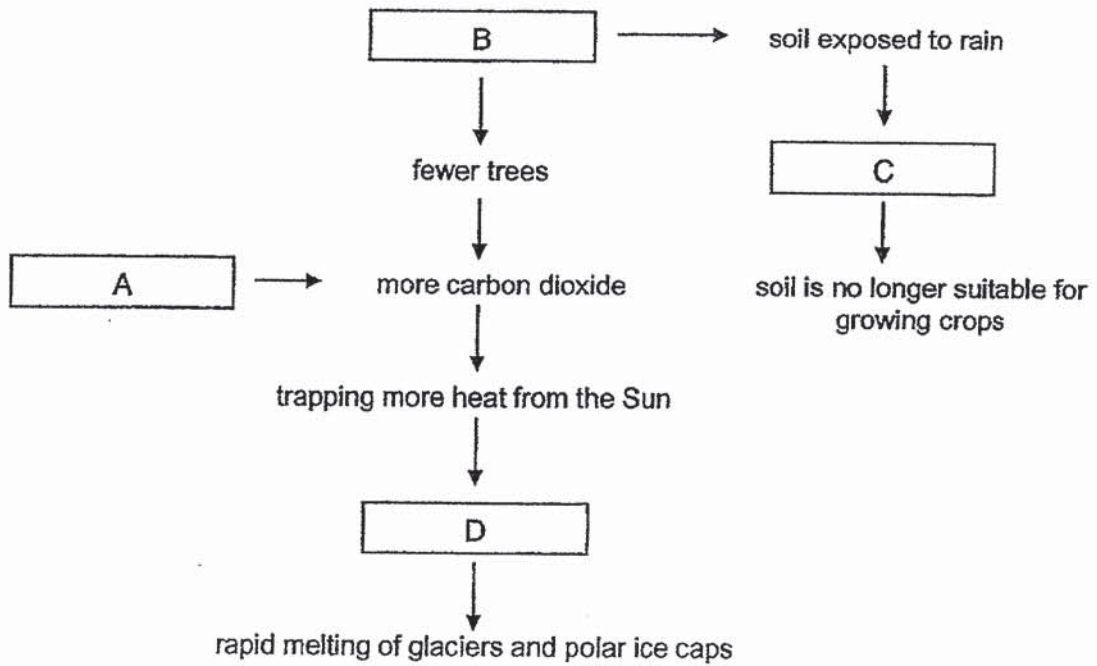

Which of the following could A, B, C and D be?

	A	B	C	D
(1)	global warming	deforestation	soil erosion	burning of fossil fuels
(2)	burning of fossil fuels	soil erosion	deforestation	global warming
(3)	global warming	soil erosion	deforestation	burning of fossil fuels
(4)	burning of fossil fuels	deforestation	soil erosion	global warming

22. The table below shows the properties of four different materials, W, X, Y and Z.

Material	How much light can pass through it?	Is it waterproof?	What is its strength?
W	No light passes through it.	Yes	Does not break easily
X	Some light passes through it.	Yes	Breaks easily
Y	Most light passes through it.	Yes	Does not break easily
Z	Most light passes through it.	No	Breaks easily

The picture below shows a box where items are placed inside it for display and prevent them from water and dirt.

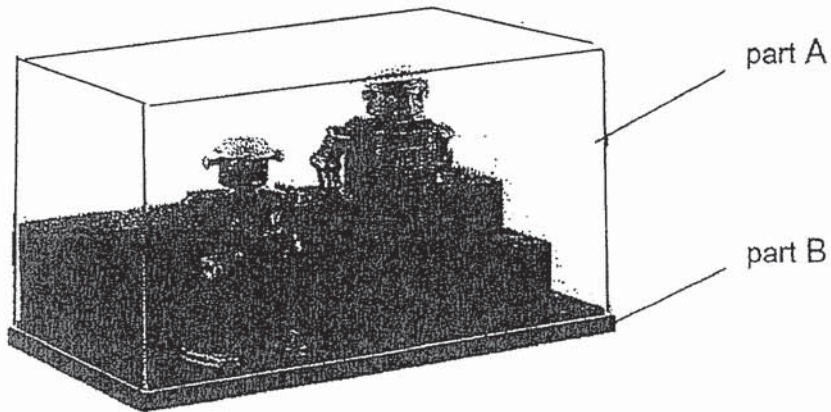

Which of the following materials, W, X, Y or Z, are most suitable for making parts A and B of the box?

	A	B
(1)	W	Y
(2)	W	Z
(3)	Y	W
(4)	Y	X

23. The diagram below shows a compass.

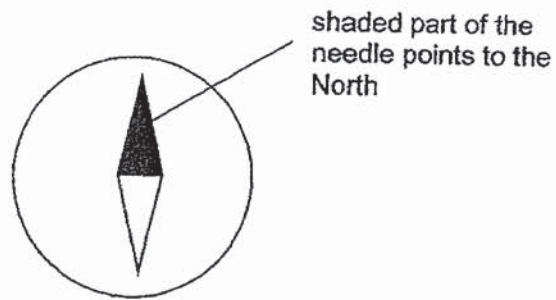

Four bar magnets were arranged such that they are attracted to one another. A compass was then placed near the end P and the direction of the compass needle is shown below.

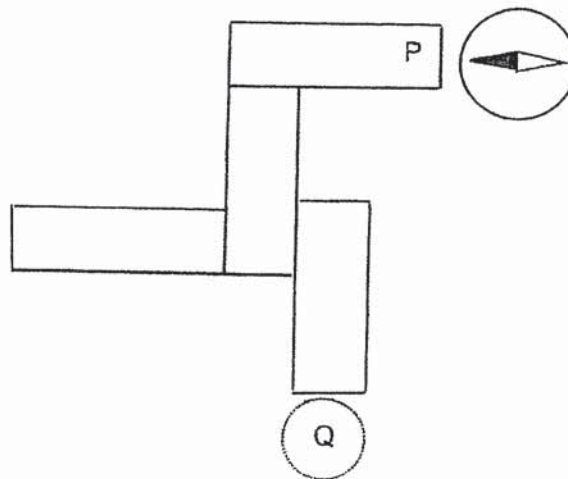

What would be the direction of the needle when the compass was placed at Q?

(1)

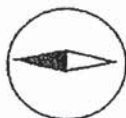

(2)



(3)

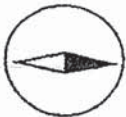

(4)



24. Janette had the following set-ups using similar batteries and iron nails. She measured the number of paper clips attracted to each iron nail.

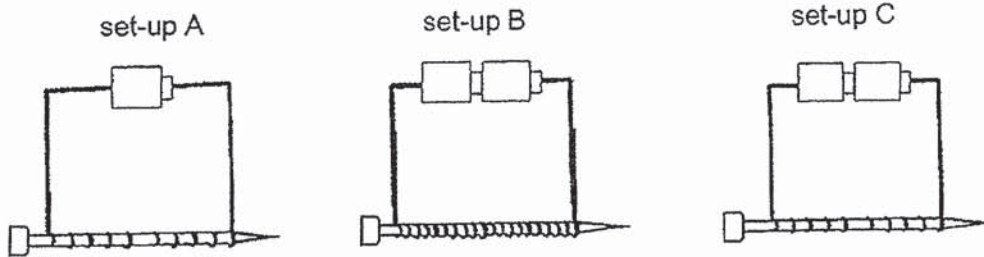

Which of the following shows correctly the order of the set-ups that attract the greatest to the least number of paper clips?

- (1) A, C, B
- (2) A, B, C
- (3) B, C, A
- (4) B, A, C

25. Study the diagram below.

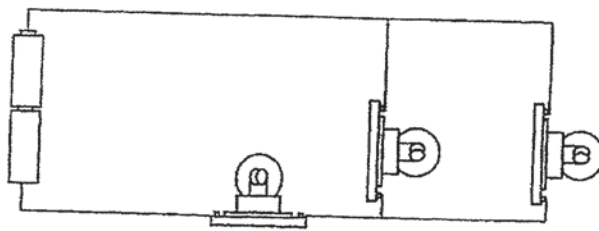

Which one of the following circuit diagrams represents the circuit above?

(1)

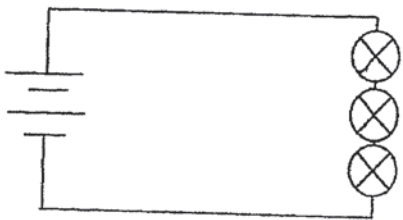

(2)

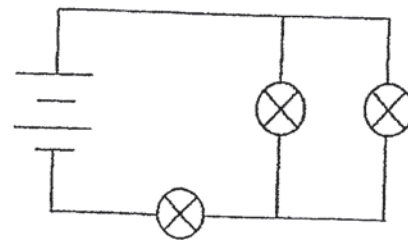

(3)

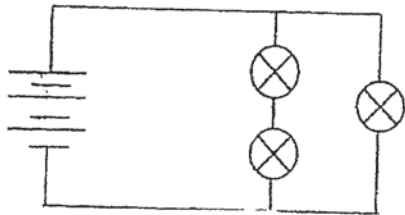

(4)

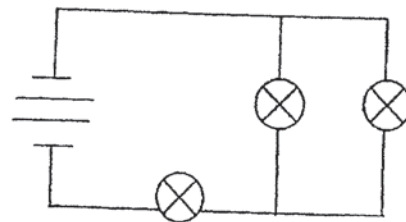

26. Four materials P, Q, R and S were connected in the electrical circuit shown below.

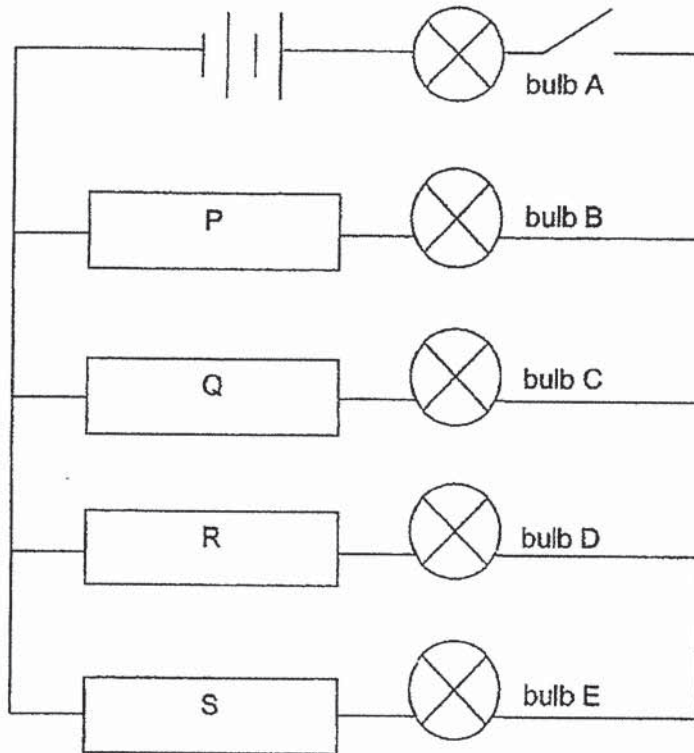

The table below shows what happened to the bulbs when the switch was closed.

Bulb	Did the bulb light up?
A	Yes
B	No
C	Yes
D	No
E	Yes

Which of the following shows the correct classification for materials P, Q, R and S?

	Conductor of electricity	Non-conductor of electricity
(1)	P, Q, R and S	-
(2)	Q and S	P and R
(3)	P and R	Q and S
(4)	-	P, Q, R and S

27. Ethan set up the circuit as shown below. He observed that all the bulbs were lit.

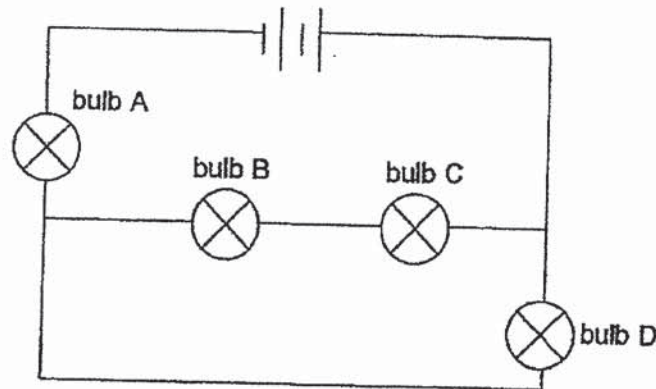

When he removed one of the bulbs, he observed that the other bulbs were not lit.

Which bulb did he remove?

- (1) bulb A
- (2) bulb B
- (3) bulb C
- (4) bulb D

28. Study the four set-ups given below. In which set-up will the bulbs be the brightest?

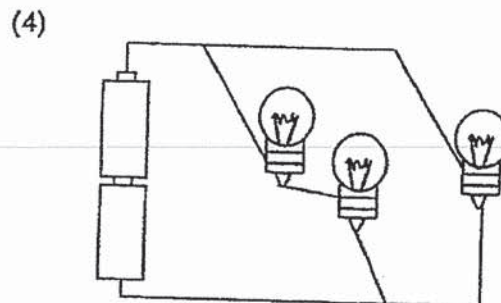
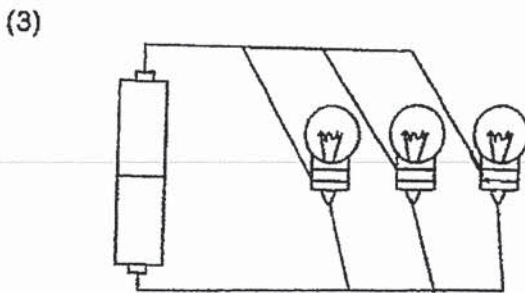
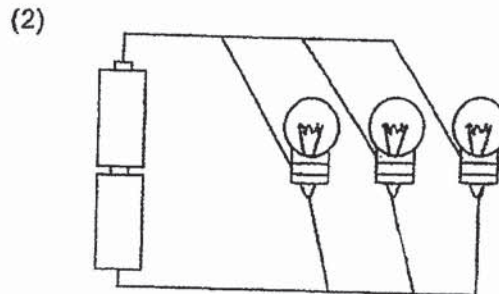
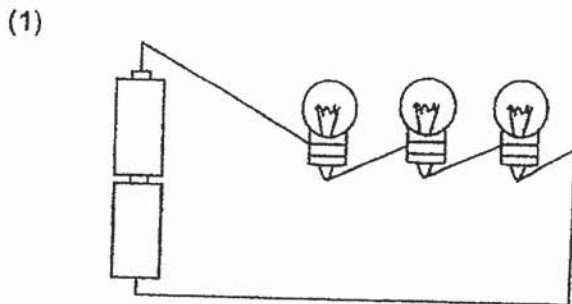

End of Booklet A



HENRY PARK PRIMARY SCHOOL
SECOND SEMESTRAL ASSESSMENT 2019
PRIMARY 5
SCIENCE
BOOKLET B (44 MARKS)

INSTRUCTIONS TO CANDIDATES

1. Do not turn over this page until you are told to do so.
2. Follow all instructions carefully.
3. Answer all questions.

Name: _____ ()

Class: Primary 5 ()

Date: 22 October 2019

Total Time: 1 h 45 min

Marks for Booklet B: _____

Section B (44 marks)

For questions 29 to 40, write your answers in this booklet.

The number of marks available is shown in brackets [] at the end of each question or part question.

29. Two cells, A and B, are shown in the diagrams below.



(a) What is the function of J? [1]

(b) Is cell A an animal or plant cell? [1]

(c) Based on the diagrams given, state one difference between cell A and cell B. [1]

30. Muthu conducted an experiment to find out if seeds can germinate without light.

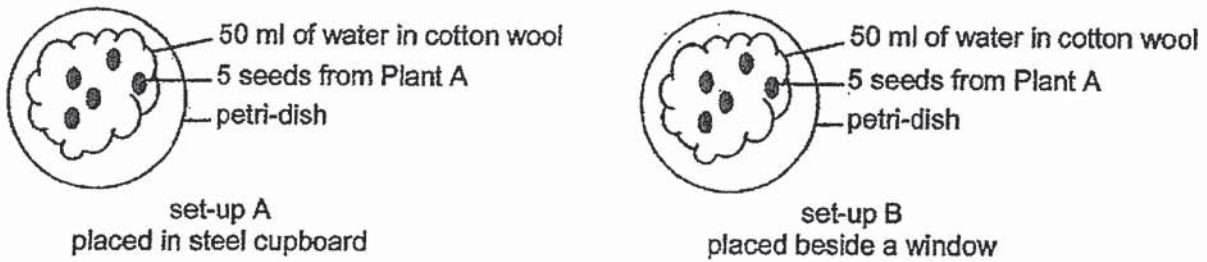

He added 50 ml of water to the cotton wool in both set-ups daily.

By the end of the first week, all the 10 seeds germinated. Muthu then concluded that seeds can germinate without light.

(a) Is Muthu's conclusion correct? Give a reason for your answer. [1]

(b) Why must he pour the same amount of water on the cotton wool in each set-up? [1]

(c) Muthu prepared two new set-ups, C and D, to find out how overcrowding affects the growth of the seeds. Set-up C was similar to set-up B shown in the diagram above.

In the table below, tick (✓) the variable(s) that Muthu must keep the same in set-up D for a fair test.

[1]

Variables	Keep the same
Number of seeds	
Amount of water	
Location of experiment	
Duration of experiment	
Height of seedlings	

31. Study the family tree below carefully.

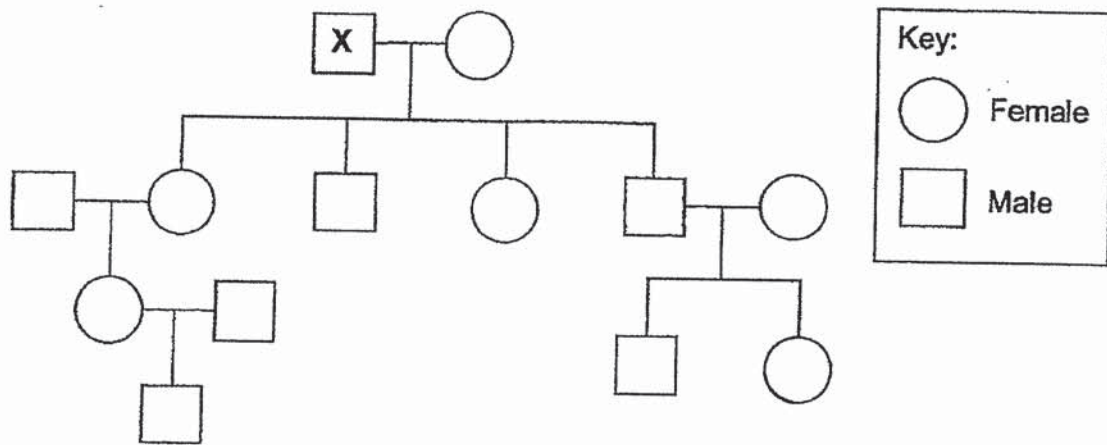

(a) Mr Tan is married. He has one brother and two sisters.

Shade the shape that represents Mr Tan.

[1]

(b) How many grandchildren does X have?

[1]

(c) Explain how both parents pass on their traits to their children.

[2]

32. The diagram below shows plant T growing in soil.

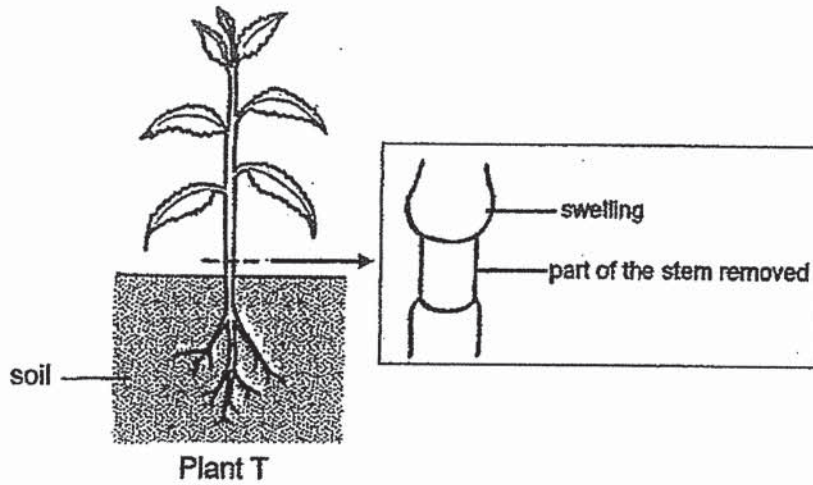

Jane removed a section of the stem of plant T as shown in the diagram above. After some days, there was swelling on the upper part of plant T where the section was removed.

(a) Explain how the swelling on the upper part was formed.

[1]

(b) After a week, Jane observed that plant T died. Explain why.

[2]

33. The lung model below shows the action of breathing in the human respiratory system.

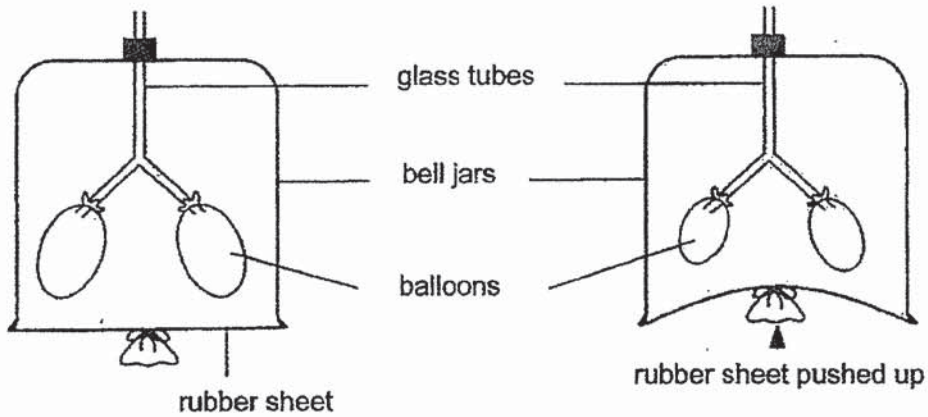

When the rubber sheet is pushed up, the balloon deflates.

(a) What do the following parts represent in the human respiratory system? [2]

(i) Glass tube : _____

(ii) Balloons : _____

(b) John ran a 100-m sprint race. After the race, John noticed that he was taking quick deep breaths and his face was red. He also observed that his pulse rate had increased after the race.

Based on the information given, explain why John's pulse rate increased after the race. [2]

34 (a) State what temperature is.

[1]

Arman set up an experiment as shown below. He placed lids at different temperatures on top of each beaker.

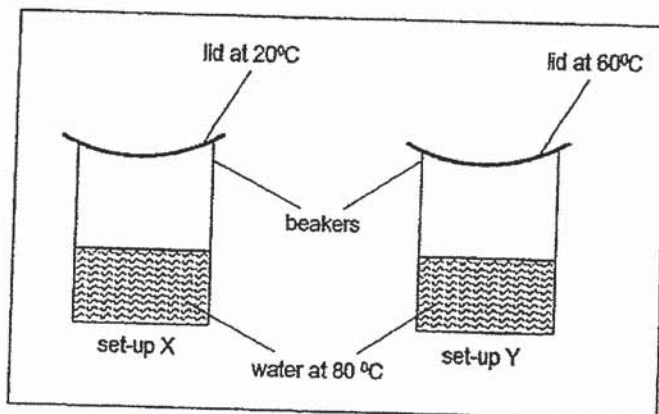

After 10 minutes, Arman noticed water droplets forming on the underside of both lids. Based on his observation, he drew the water droplets formed on the underside of the lid in set-up Y as shown in the diagram below.

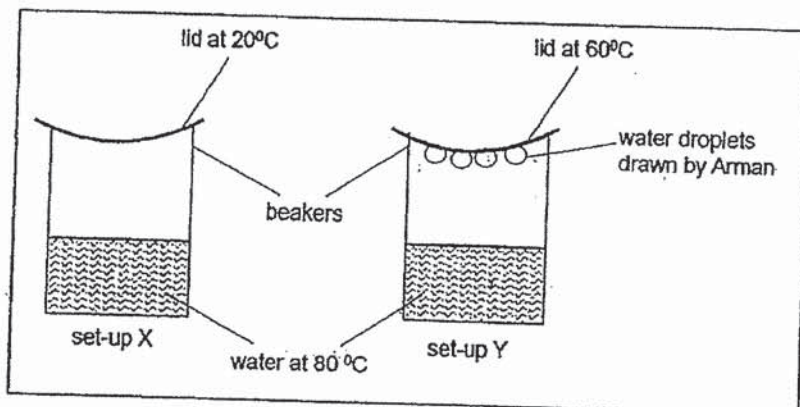

(b) State if the number of water droplets formed on the underside of the lid in set-up X will be **more**, **less** or the **same** as the number of water droplets formed on the underside of the lid in set-up Y [1]

(c) Explain your answer in (b). [2]

35. Joyce had a beaker of water. She placed a ball of plasticine into the water and the water level rose to water level X.

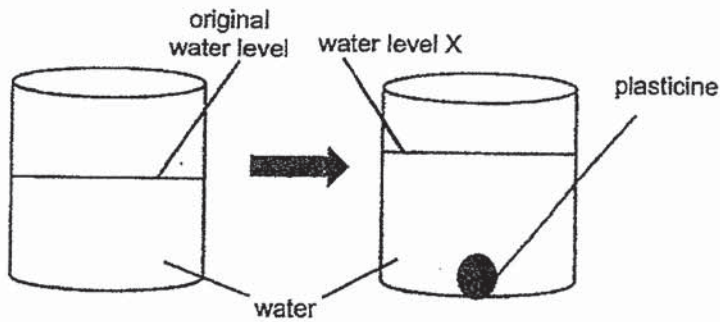

She then flattened the plasticine as shown below and placed it back into the beaker of water. There was no loss of water during this process.



Plasticine is flattened

- (a) How does the water level in the beaker containing the plasticine change before and after it is flattened? [1]

- (b) Explain your answer in (a). [1]

Question 35 continued

In the story, "*The Crow and the Pitcher*", the crow dropped several pebbles into the pitcher so that it could drink the water.



- (c) Why did the water level increase in the pitcher when the pebbles were dropped into the pitcher? [1]

- (d) Besides dropping the stones more quickly, suggest **another** way to make the water level in the pitcher increase more quickly. [1]

- (e) The water level did not increase when some dead leaves were dropped into the pitcher. [1]

Explain why.

36. Mrs Tan is cooking a pot of fishball noodle soup with a ladle.



Pot of hot fishball noodle soup

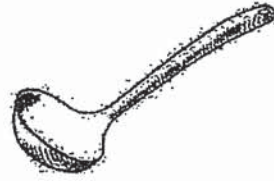

Ladle for stirring

Mrs Tan has 2 ladles, one made of wood and the other made of metal.

- (a) She decided to use the wooden ladle to stir the hot soup so that her hands will not feel hot. Explain why. [2]

As she wanted the noodles to cool down faster, Mrs Tan lifted the hot noodles out of the soup as shown in the diagram below.

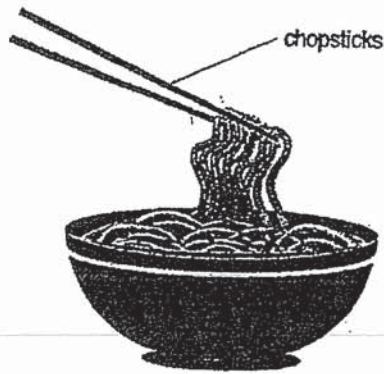

- (b) Explain how lifting the hot noodles up cool them down more quickly. [2]

37. The diagram below shows the water heater system in Mrs Lee's home.

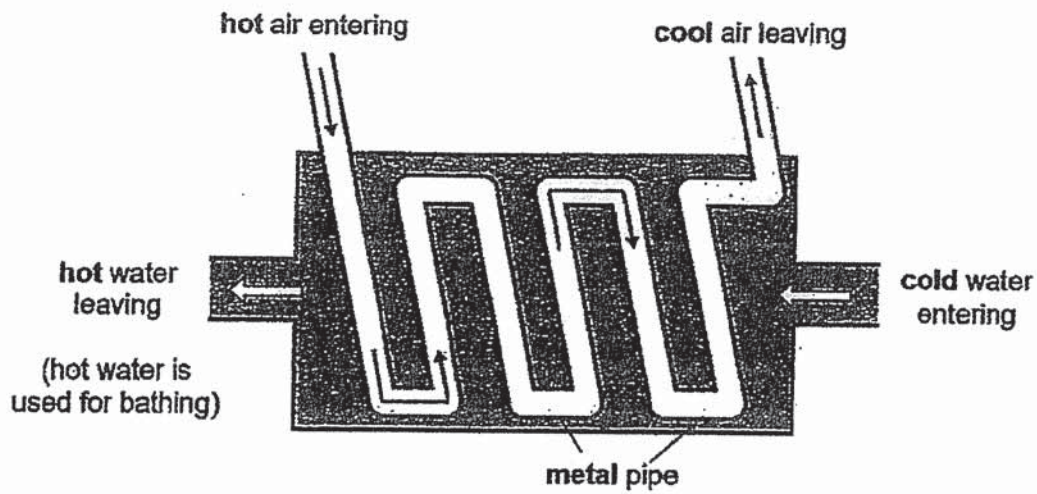

Water Heater

- (a) Based on the diagram given, explain how the cold water becomes hot in the water heater. [1]

- (b) Besides using a thinner metal pipe, suggest **another** improvement Mrs Lee can make to the **metal pipe** in the water heater to obtain hotter water. Explain your answer. [2]

Suggestion: _____

Explanation: _____

38. John laid material A in the funnel and placed the funnel on a measuring cylinder. He poured 50 ml of water into the funnel and measured the water collected in the cylinder.

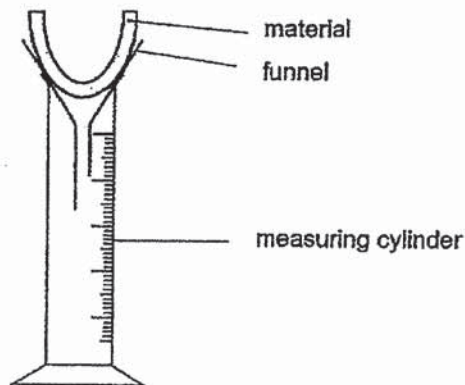

He repeated the experiment with materials B and C and recorded the results in the table below. He noticed that water was either absorbed by the material or was collected in the measuring cylinder.

Material	Amount of water collected in the measuring cylinder (ml)
A	0
B	49
C	38

- (a) State the independent and dependent variables in this experiment. [2]

Independent variable : _____

Dependent variable : _____

- (b) What is the aim of the experiment? [1]

The diagram below shows a hand towel.

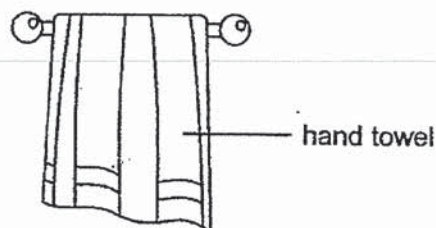

- (c) Which material, A, B, or C, is **most** suitable for making the hand towel? Explain why. [2]

39. Dylan used the set-up as shown below to find out how much materials W, X, Y and Z bent when a 50g load was hung.

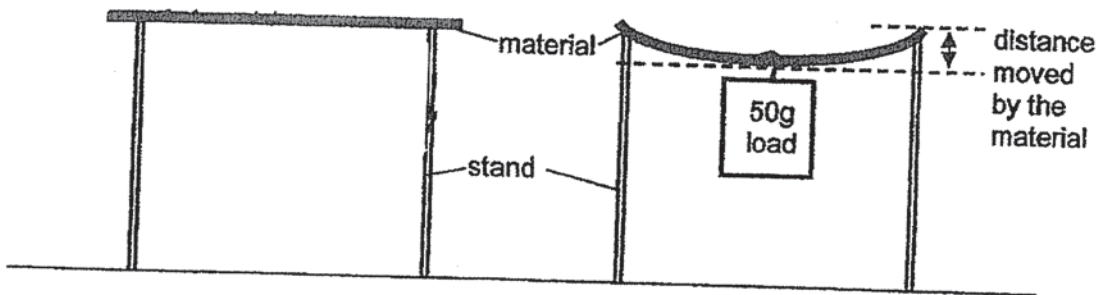

He continued to add more 50g loads until the material broke.

The table below shows the distance moved by the material and the load needed to break the material.

Material	Distance moved by the material when a 50g load was hung (cm)	Number of 50g loads added until the material broke
W	5	7
X	5	2
Y	3	4
Z	2	7

The diagram below shows a food tray.

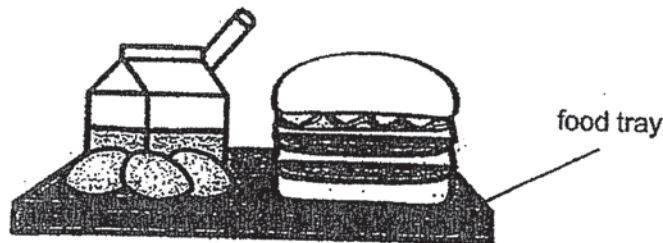

Based on the results of Dylan's experiment, which material, W, X, Y or Z, is most suitable for making the food tray? Explain your answer. [2]

40. The diagram below shows a button.

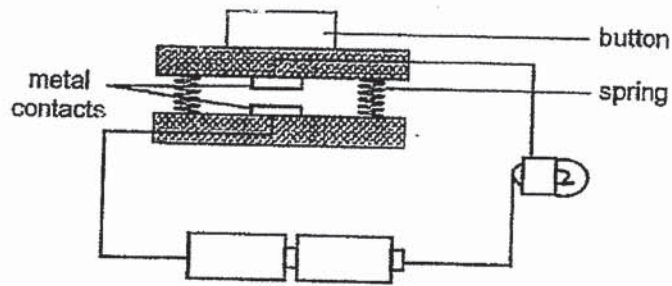

(a) What will happen to the bulb when the button is pressed down? Explain why. [2]

(b) The metal contacts are changed to rubber contacts.
What will happen to the bulb when the button is pressed down? Explain why. [2]

End of Booklet B

- 1. 3
- 2. 2
- 3. 4
- 4. 4
- 5. 3
- 6. 2
- 7. 4
- 8. 4
- 9. 1
- 10. 3

- 11. 4
- 12. 2
- 13. 1
- 14. 3
- 15. 2
- 16. 4
- 17. 3
- 18. 4
- 19. 3
- 20. 2

- 21. 4
- 22. 3
- 23. 2
- 24. 3
- 25. 2
- 26. 2
- 27. 1
- 28. 2

1011

1011

1011

Name: _____ () Class: _____

Booklet B

Question	Suggested answer
29a	It controls the movement of substances in and out of the cell.
29b	Animal cell
29c	Cell B has a cell wall but cell A does not.
30a	Yes. The seeds in set-up A germinated without light.
30b	It is to ensure it is the presence or absence of light that affects seed germination.
30c	Variables to be kept the same: amount of water, location of experiment, duration of experiment
31a	
31b	3
31c	<i>The genetic information is in the nucleus of the egg and the nucleus of the sperm. When the nucleus of the egg and the nucleus of the sperm fuse during fertilisation, the genetic information is passed on to the young.</i>
32a	The food-carrying tubes had been removed. Food made in the leaves could not be transported beyond the cut section and thus accumulated there.
32b	Food made in the leaves could not be transported to the roots, thus the roots died and could not take in water for the plant.
33a	Glass tube: windpipe Balloons: lungs
33b	The body needs more energy. The heart pumps blood containing oxygen and digested food more quickly to other parts of the body. The body produces more carbon dioxide which has to be transported by the blood to the lungs for removal.
34a	Temperature is a measurement of how hot something is.

2019 P5 SA2 Science
Correction Sheet

34b	more
34c	The lid in set-up X is colder than the lid in set-up Y. The water vapour in the beaker loses heat more quickly to the underside of the lid and condenses more quickly.
35a	The water level remains the same.
35b	The plasticine has a definite volume.
35c	The pebbles took up space in the water.
35d	Drop bigger pebbles into the pitcher.
35e	The dead leaves floated on the water and did not take up space in the water.
36a	Wood is a poorer conductor of heat than metal. It will conduct heat more slowly from the hot soup to her hands.
36b	It increases the exposed surface area of the noodles, thus more heat will be lost from the noodles to the surrounding air.
37a	The metal pipe conducts heat from the hot air to the cold water.
37b	Suggestion: Use a longer metal pipe Explanation: The hot air takes a longer time to pass through, thus the cold water will gain more heat from the hot air.
38a	Independent variable: Type of material Dependent variable: Amount of water in the measuring cylinder
38b	It is to find out how much water different materials absorb.
38c	Material A. It absorbs the most amount of water, thus it can dry the hands most quickly.
39	Material Z. It holds the most number of loads before breaking, thus it is the strongest and able to carry heavy food items. It bends the least with the same amount of 50g load hung on it, thus it is least flexible and will not bend easily when carrying food items.
40a	The bulb will light up. The metal contacts touch each other and the circuit is closed, allowing electricity to flow through.
40b	The bulb will not light up. Rubber is a non-conductor of electricity and there is an open circuit, thus electricity cannot flow through.