

SINGAPORE CHINESE GIRLS' SCHOOL
PRIMARY 5 SCIENCE

Term 1 WA

Term 1 Weighted Assessment

Topics: Heredity, Reproduction in Humans and Reproduction in Plants

Name: _____ ()

Date: _____

Class: Primary 5 SY / C / G / SE / P

	Total Actual Marks	Total Possible Marks
Section A		14
Section B		11
Total		25

_____ Parent's signature

Section A (14 marks)

For each question from 1 to 7, four options are given. One of them is the correct answer. Choose the correct answer and write its number in the Answer Sheet on Page 4.

1. Which one of the following traits cannot be passed down from one generation to the next?

- (1) Fingerprints
- (2) Type of eyelids
- (3) Hitchhiker's thumb
- (4) Ability to roll tongue

2. The table below records some of the characteristics of Janice's parents.

		Mother	Father
Characteristics	Hair	Straight and brown	Wavy and black
	Height	Short	Tall
	Earlobe	Attached	Attached
	Dimples	No dimples	No dimples

Which one of the following descriptions of Janice shows the characteristics she can most likely inherit from her parents?

- (1) Janice is tall, has dimples and has short hair.
- (2) Janice is tall, has no dimples and has detached earlobes.
- (3) Janice is short, has dimples and has attached earlobes.
- (4) Janice is short, has no dimples and has brown hair.

3. The diagram below shows the reproductive system of a woman.

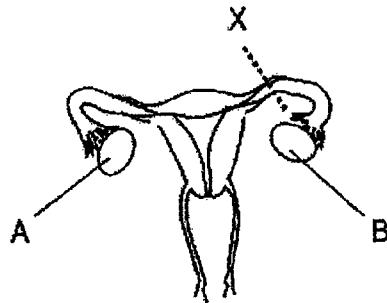

Will a woman be able to have a baby if she undergoes a procedure where a single cut is made at X? Why?

- (1) No. There will not be any eggs left.
- (2) No. The eggs cannot move to the womb.
- (3) Yes. Eggs produced by Part A can still move to the womb.
- (4) Yes. Sperms produced by Part A can still move to the womb.

4. Study Eva's family tree below.

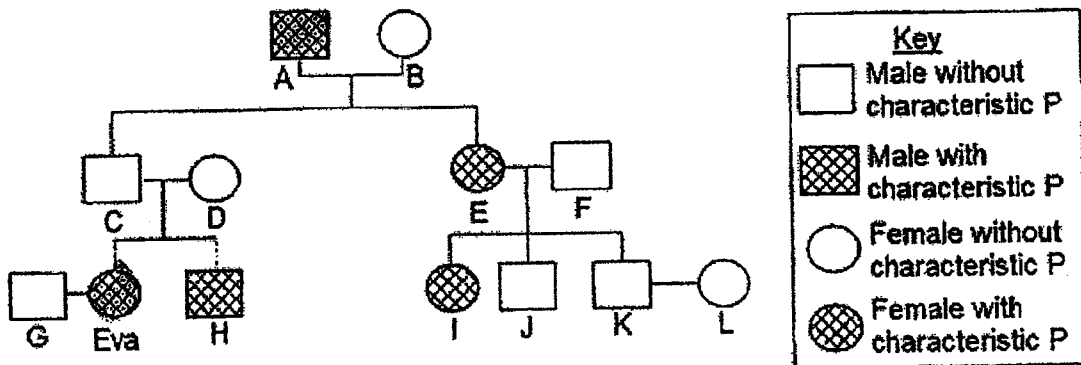

Based on the family tree above, who did Eva inherit characteristic P from?

- (1) A
- (2) E
- (3) H
- (4) I

5. Which of the following best describes the importance of seed dispersal?

- A : To prevent overcrowding
- B : To increase the seedling's chances of survival
- C : To enable the young plant to obtain enough nutrients from the parent plant
- D : To allow the young plant to have the same characteristics as the parent plant

- (1) A and B only
- (2) B and C only
- (3) A, B and C only
- (4) All of the above

6. The diagram below shows a flower.

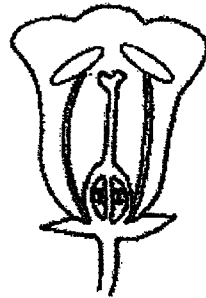

The flowers below are the same type of flower with different parts removed from them. From which of the flowers, A, B, C or D will a fruit be able to develop?

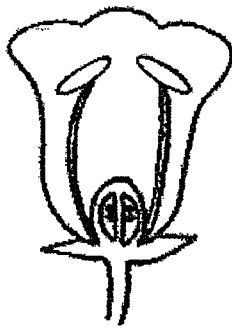

A

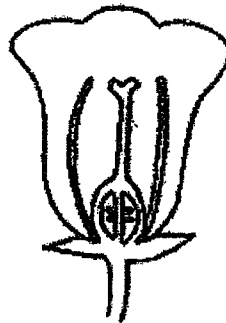

B

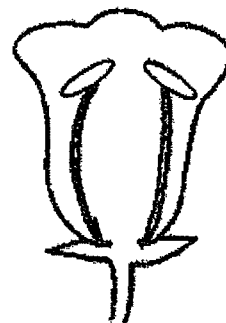

C



D

- (1) A and B only
- (2) A and C only

- (3) B and D only
- (4) A, B and C only

7. Study the diagrams below carefully.

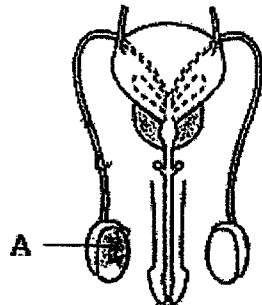

Human Reproductive System

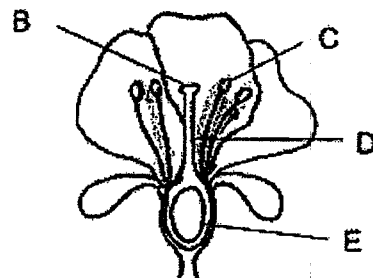

Plant Reproductive System

Which one of the following parts performs a similar function as Part A?

- (1) B
- (2) C

- (3) D
- (4) E

Term 1 WA

SINGAPORE CHINESE GIRLS' SCHOOL
PRIMARY 5 SCIENCE

Term 1 Weighted Assessment

Topics: Heredity, Reproduction in Humans and Reproduction in Plants

Name: _____ ()

Class: Primary 5 SY/C/G/SE/P

<u>Answer Sheet for Section A</u>		
1. ()	4. ()	7. ()
2. ()	5. ()	
3. ()	6. ()	

Section B (11 marks)

For Questions 8 to 10, write your answers in the space provided.

8a. The diagram below shows the processes in the reproduction of flowering plants.

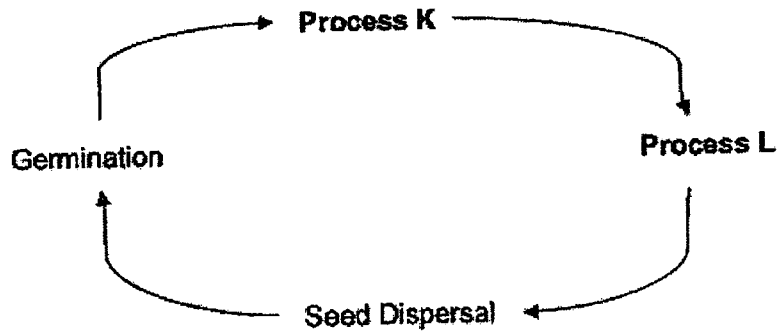

Name the processes in the diagram above:

(2m)

Process K : _____

Process L : _____

8b. Seed dispersal ensures that seedlings do not need to compete with the parent plant for _____ and mineral salts. (2m)

9a. Look at the diagram below.

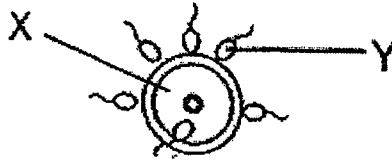

Name the parts that produce the human reproductive cells X and Y. (1m)

X: _____

Y: _____

9b. Study the family tree below carefully.

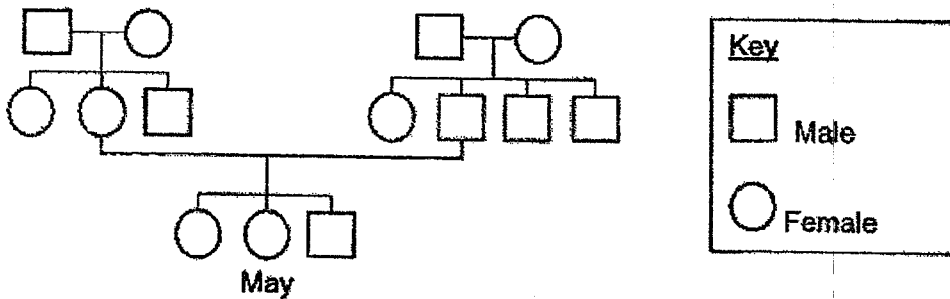

Put a tick (✓) in the correct boxes to indicate if each statement is True or False. (2m)

	True	False
(i) May has two siblings.		
(ii) May has a total of two aunts.		
(iii) May's father has two sister and a brother.		
(iv) There are more females than males in May's family tree.		

10. The diagram below shows two deserted islands, P and Q, which are surrounded by the sea. Only birds and reptiles live in both islands.

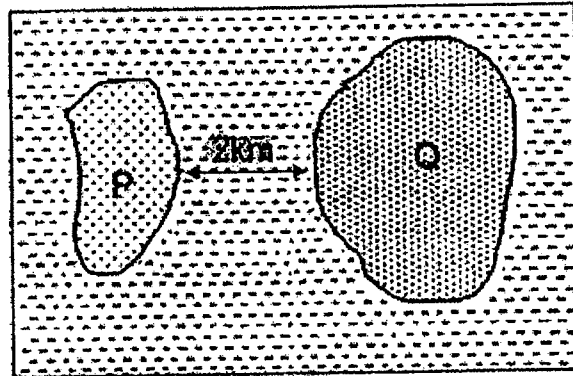

Ten years ago, four types of plants, E, F, G and H were found growing on Island P but none of these were found growing on island Q. The table below shows the characteristics of the fruits from the four plants, E, F, G and H.

Plant	Characteristic of fruit
E	Fibrous husk
F	Light, hairy
G	Sweet, juicy
H	Dry and hard, pod-like

- a. Now, new plants are found growing on Island Q. Which plant/s, E, F, G, H could they possibly be? (2m)

- b. State the method of dispersal for: (2m)

Plant E : _____

Plant H : _____

End of Paper

SCHOOL : SCGS PRIMARY SCHOOL
 LEVEL : PRIMARY 5
 SUBJECT : SCIENCE
 TERM : 2022 WA1

SECTION A

Q 1	Q2	Q3	Q4	Q5	Q6	Q7
1	4	3	1	1	3	2

SECTION B

Q8)	<p>a) Process K: Pollination Process L: Fertilisation</p> <p>b) <u>Space</u> , <u>sunlight</u> , <u>water</u></p>												
Q9)	<p>a) X: ovary Y: testes</p> <p>b)</p> <table border="1"> <tbody> <tr> <td>i)</td> <td>√</td> <td></td> </tr> <tr> <td>ii)</td> <td>√</td> <td></td> </tr> <tr> <td>iii)</td> <td></td> <td>√</td> </tr> <tr> <td>iv)</td> <td></td> <td>√</td> </tr> </tbody> </table>	i)	√		ii)	√		iii)		√	iv)		√
i)	√												
ii)	√												
iii)		√											
iv)		√											
Q10)	<p>a) E , F , G</p> <p>b) Plant E: Water Plant H: Splitting</p>												

