

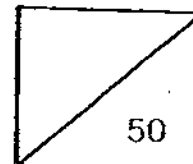

Rosyth School
First Continual Assessment for 2009
STANDARD SCIENCE
Primary 6



Name: _____

Total
Marks:

Class: Pr _____

Register No. _____

Duration: 1 h 15 min

Date: 4th March 2009

Parent's Signature: _____

Instructions to Pupils:

1. Do not open the booklets until you are told to do so.
2. Follow all instructions carefully.
3. This paper consists of 2 sections, Part I and Part II.
4. For questions 1 to 15 in Part I, shade the correct ovals on the Optical Answer Sheet (OAS) provided using a 2B pencil.
5. For questions 16 to 23, give your answers in the spaces given in Part II.

	Maximum	Marks Obtained
Part I	30 marks	
Part II	20 marks	
Total	50 marks	

* This booklet consists of 16 pages. (Pg. 1 to 16)

This paper is not to be reproduced in part or whole without the permission of the Principal.

PART I (30 MARKS)

For each question from 1 to 15, four options are given. One of them is the correct answer. Make your choice (1, 2, 3 or 4). Shade the correct oval (1, 2, 3 or 4) on the Optical Answer Sheet.

1. The diagram shows 2 groups of animals.

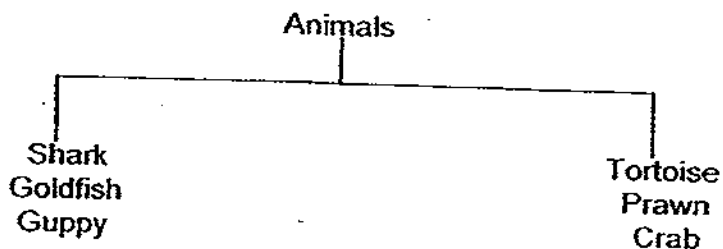

Which one of the following statements is true?

- (1) The two groups of animals are fish and reptiles.
- (2) The animals are classified according to the way they move.
- (3) The animals are classified according to their body covering.
- (4) The two groups of animals are vertebrates and invertebrates.

2. The classification table below shows the classification of ant, elephant, paramecium, mushroom, yeast and African Tulip into two groups X and Y.

Group X	Group Y
ant elephant paramecium	mushroom mould African Tulip

What characteristic(s) can be used to classify them into groups, X and Y?

- A: nutrition
 - B: movement
 - C: body form
 - D: method of reproduction
- (1) A only
 - (2) B only
 - (3) A and D only
 - (4) B and C only

Rosyth School/ Continual Assessment 1/ Standard Science/ P6/ 2009

3. The diagram below shows an incomplete classification chart of a group of living things G.

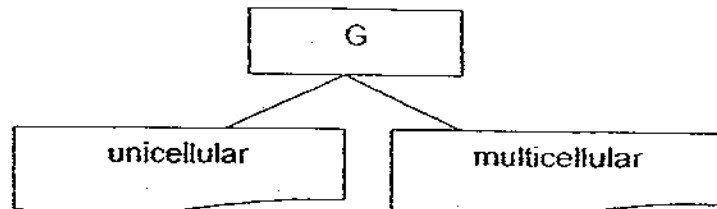

Which one of the following is G likely to be?

- A: Fungi
- B: Plants
- C: Animals
- D: Microorganisms

- (1) C only
- (2) A and D only
- (3) B and C only
- (4) B and D only

4. Study the classification chart below.

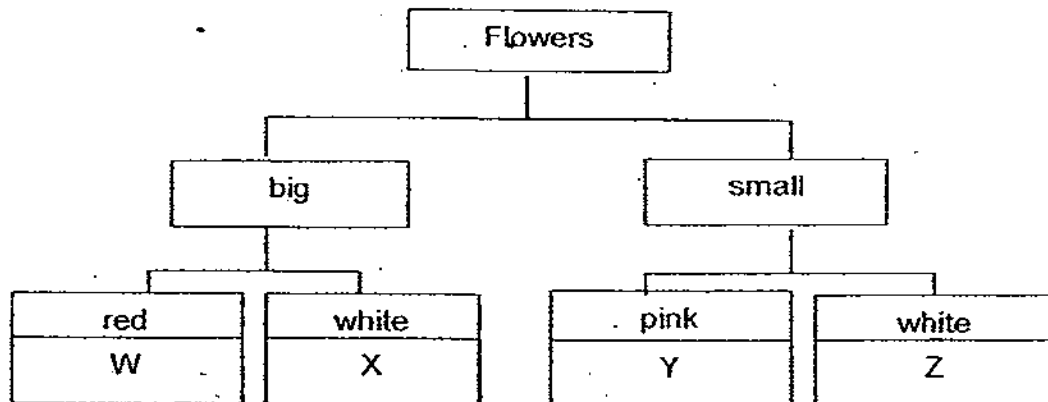

Peter observed the number of times insects visited the four kinds of flowers in an hour. Which one of the following correctly matches the flower to the number of visits by insects?

	Visited by insects 35 times	Visited by insects 6 times	Visited by insects 17 times
(1)	W	Z	Y
(2)	Y	X	Z
(3)	Z	W	X
(4)	X	Y	W

Rosyth School/ Continual Assessment 1/ Standard Science/ P6/ 2009

5. Which of the following characteristics can differentiate a bird from all other groups of animals?
- A: Ability to fly
 - B: Have two legs
 - C: Presence of scales
 - D: Presence of feathers

- (1) A and D only (2) B and D only
 (3) A, B and C only (4) B, C and D only

6. The diagram below shows an electric circuit. M1, M2 and M3 are different types of materials.

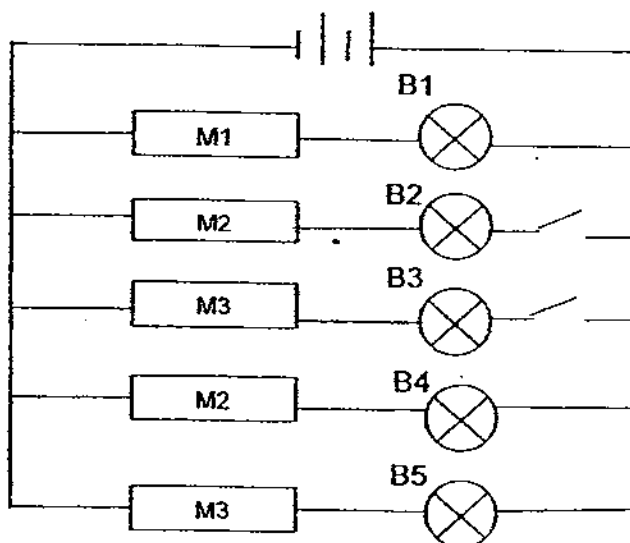

Muthu observed that only bulbs B1 and B5 lit up in the circuit above. Which of the following state(s) the property or properties of the materials M1, M2 and M3 correctly?

- A: M1 is an insulator of electricity.
- B: M2 is an insulator of electricity.
- C: M3 is a conductor of electricity.

- (1) A only (2) C only
 (3) A and B only (4) B and C only

Roysth School/ Continual Assessment 1/ Standard Science/ P6/ 2009

7. Chris had four rods made of different materials. She wanted to find out which material was the hardest. Each time, she took one rod to scratch another. She recorded her results in a table as shown below.

	Rod A	Rod B	Rod C	Rod D
Rod A	-	No scratches on B	No scratches on C	No scratches on D
Rod B	Deep scratches on A	-	Fine scratches on C	Moderate scratches on D
Rod C	Moderate scratches on A	No scratches on B	-	Fine scratches on D
Rod D	Fine scratches on A	No scratches on B	No scratches on C	-

Which of the following shows the correct order of hardness of material in ascending order?

- (1) A, D, C, B (2) D, A, B, C
 (3) C, D, A, B (4) B, C, D, A
8. A ball is placed at position A and then released to roll down the curved track. The ball reached a maximum position before it rolled back.

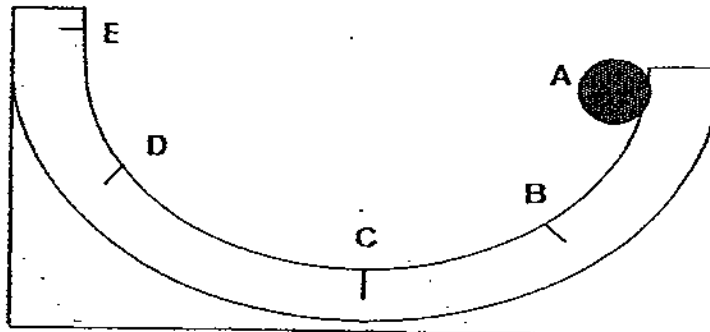

Which would be the maximum position the ball would reach when it is released?

- (1) B (2) C
 (3) D (4) E

Rosyth School/ Continual Assessment 1/ Standard Science/ P6/ 2009

9. The diagram below shows a ball's path after it was thrown into the air.

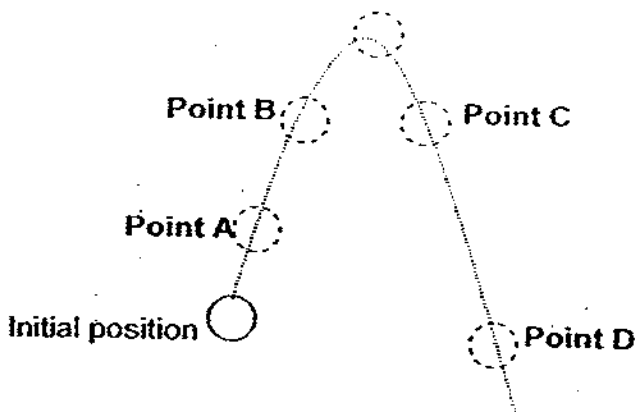

The ball's amount of potential and kinetic energy changed continuously as it moved. Which one of the following shows the greater energy that ball possessed at each of the points correctly?

	A	B	C	D
(1)	kinetic	potential	potential	kinetic
(2)	kinetic	potential	kinetic	potential
(3)	potential	Kinetic	kinetic	potential
(4)	potential	kinetic	potential	kinetic

10. The diagram below shows a hydroelectric power station. The turbine is built below level of the lake.

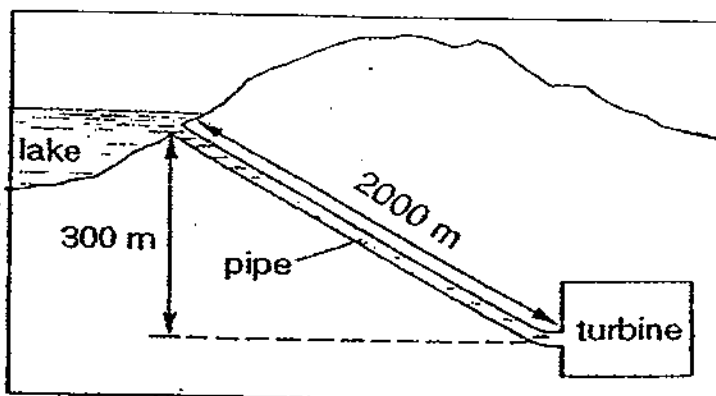

What are the main energy changes in a hydroelectric power station?

- (1) kinetic → heat → electrical
- (2) heat → kinetic → electrical
- (3) potential → kinetic → potential
- (4) potential → kinetic → electrical

Rosyth School/ Continual Assessment 1/ Standard Science/ P6/ 2009

11. Look at the diagram below.

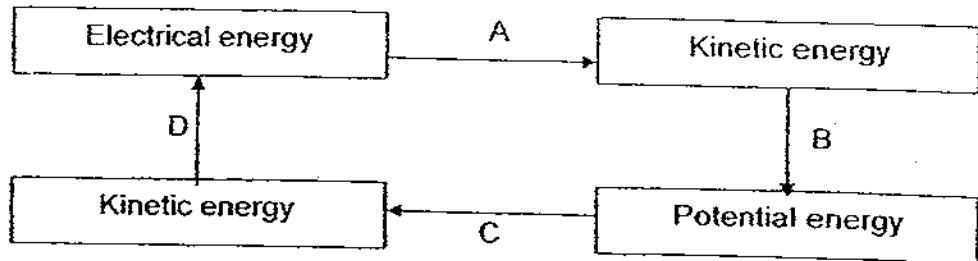

Which of the following represents A, B, C and D?

	A	B	C	D
(1)	An escalator	Firing a pistol	Closing a Jack-in-the-box	A dynamo
(2)	An electric shaver	Climbing a flight of stairs	Burning charcoal	Pressing the lift button
(3)	A fan blowing	Winding a toy robot	Compressing a spring	An electric drill
(4)	A roller coaster in motion	Stretching a spring	Shooting an arrow	A wind turbine

12. The diagram shows part of a flower at one stage during reproduction.

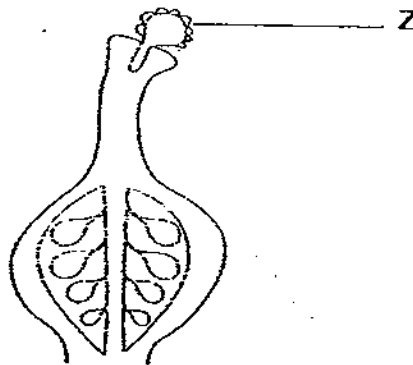

The pollen grain Z has undergone process A but not process B. What are processes A and B?

	A	B
(1)	pollination	dispersal
(2)	dispersal	germination
(3)	pollination	fertilisation
(4)	fertilisation	germination

Rosyth School/ Continual Assessment 1/ Standard Science/ P6/ 2009

13. The diagram below shows a wind-pollinated flower.

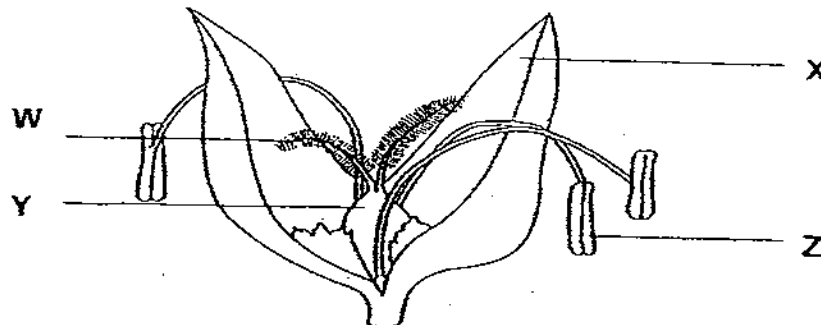

Which one of the structures W, X, Y or Z does not play an important role in the process of pollination?

- | | |
|-------|-------|
| (1) W | (2) X |
| (3) Y | (4) Z |

14. The diagram below shows a box fruit.

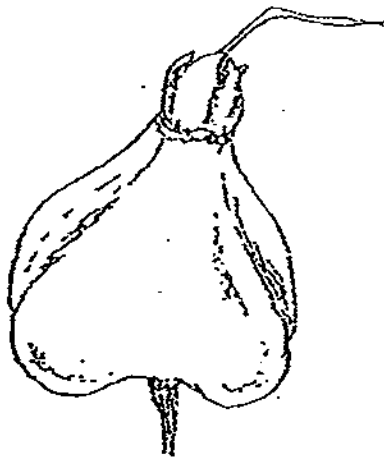

Jimmy wants to find out if the fruit is scattered by water. He plans to do the following.

- A: Put it in water and see if it floats.
- B: Shake it to see if it contains water.
- C: Examine it to see if it has a fibrous husk.
- D: Examine it to see if it has ridges.

Which of the above action(s) is/are not useful?

- | | |
|-------------|-------------|
| (1) B only | (2) C only |
| (3) A and C | (4) B and D |

Rosyth School/ Continual Assessment 1/ Standard Science/ P6/ 2009

15. The diagram shows a ginger plant and a beetroot plant.

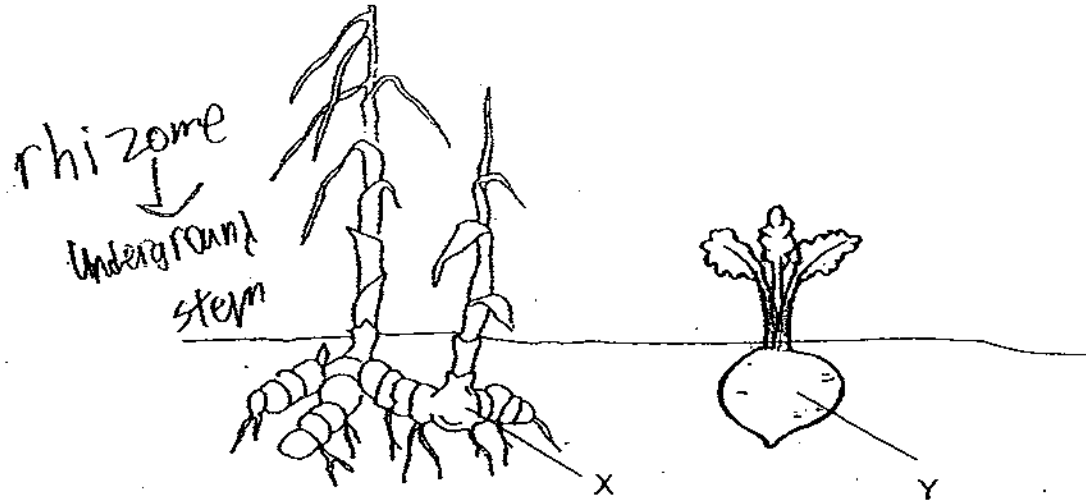

Which of the following statements correctly state the similarities between part X and Y.

- A: Both parts store food.
- B: Both parts are underground roots.
- C: Both parts absorb water and mineral salts.
- D: Both parts provide additional anchorage for the plants.

- | | | | |
|-----|-----------------|-----|-----------------|
| (1) | A and D only | (2) | B and C only |
| (3) | A, B and C only | (4) | B, C and D only |

End of Part I

Rosyth School/ Continual Assessment 1/ Standard Science/ P6/ 2009

PART II (20 MARKS)

For questions 9 to 16, write your answers in this booklet.

16. Study the organisms below.

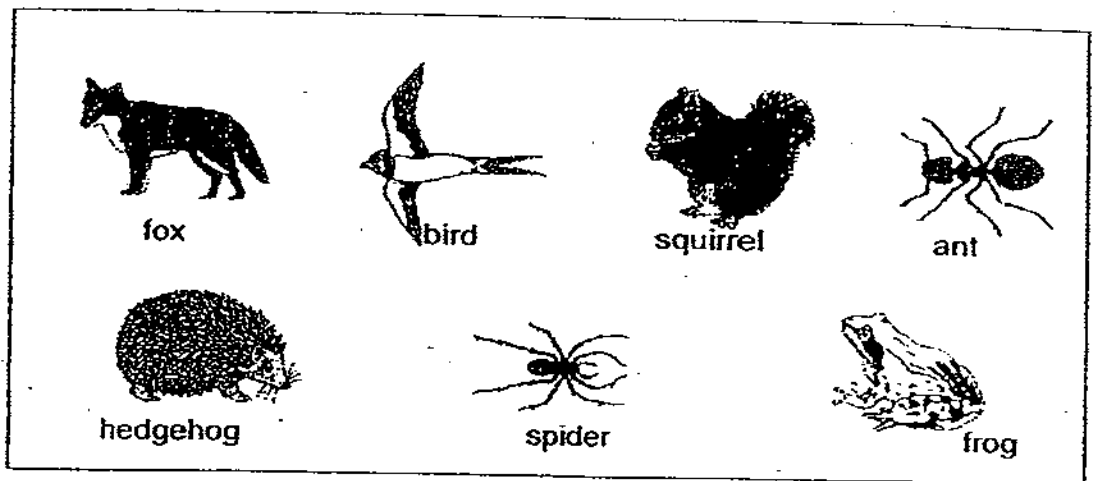

Carrie classified the animals using the classification chart shown below.

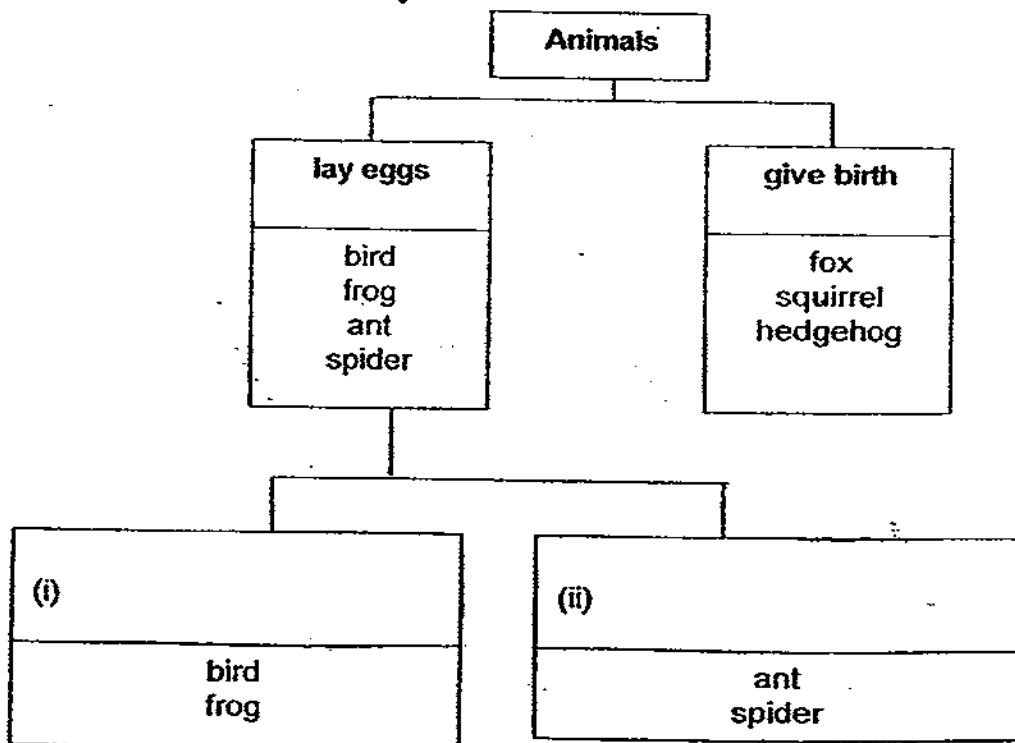

(a) State the sub-headings for (i) and (ii) in the boxes above.

[1]

(Question 16 is continued on page 10)

Rosyth School/ Continual Assessment 1/ Standard Science/ P6/ 2009

Then Carrie measured the body temperatures of the bird and the frog at room temperatures from 10°C to 30°C. She drew two graphs from her results.

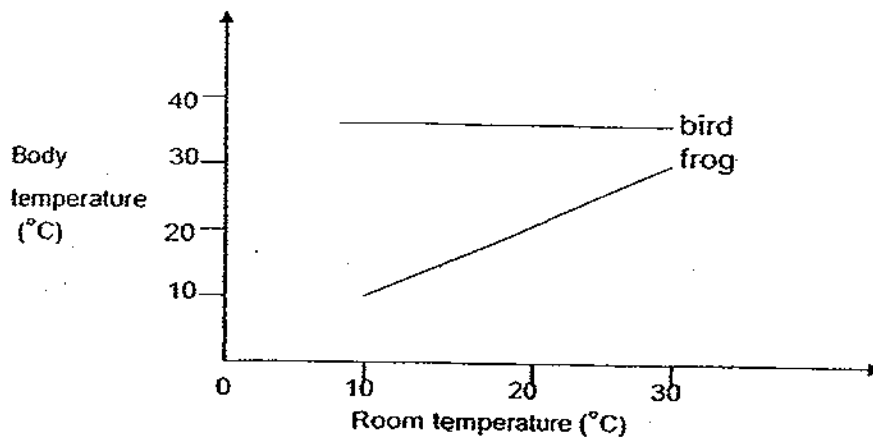

Based on the results, Carrie further classified bird and frog into two groups as shown below.

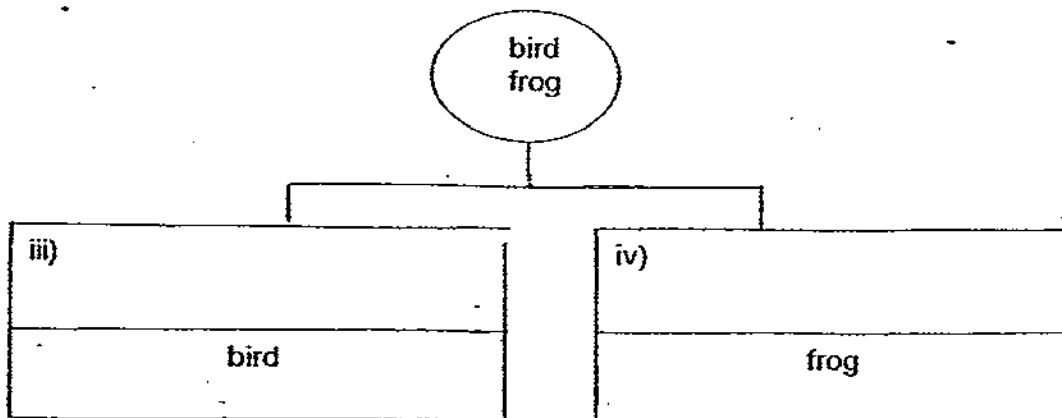

(b) State the two sub-headings for (iii) and (iv) in the boxes above.

{1}

Roysth School/ Continual Assessment 1/ Standard Science/ P6/ 2009

17. Study the classification chart for some leaf samples below and use it to answer the following questions.

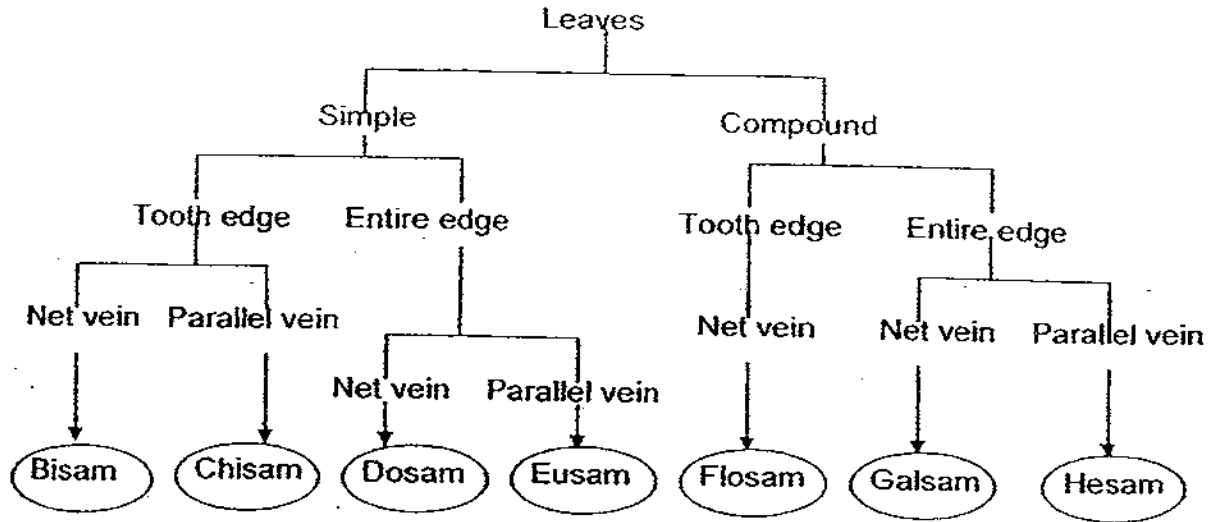

- (a) Write down the characteristics of a Bisam leaf. [1]

- (b) Observe the two leaves carefully and identify them. [1]

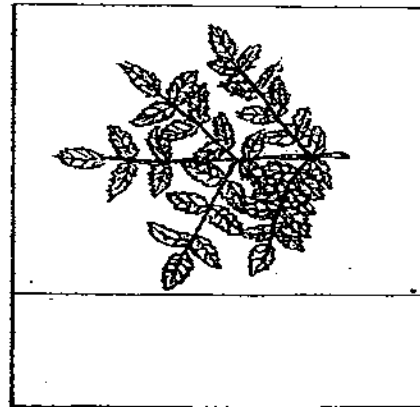
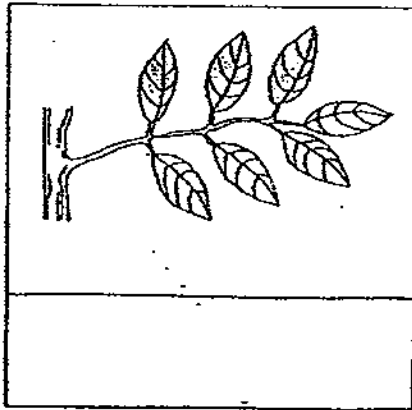

- (c) Draw an Eusam leaf in the box below. [1]

Eusam

Rosyth School/ Continual Assessment 1/ Standard Science/ P6/ 2009

18. Study the diagram below.

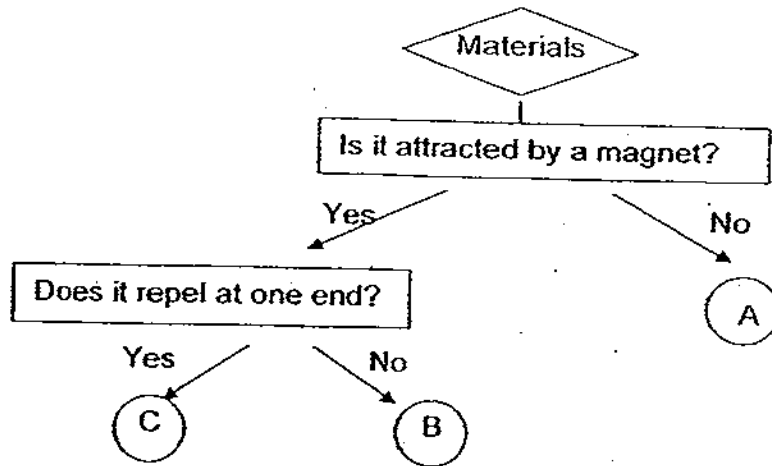

Based on the flow chart, Keli made the following statements. Put a tick (✓) in the appropriate boxes to indicate whether the statements are 'True', 'False' or 'Not Possible to Tell'. [2]

	Keming's statements	True	False	Not Possible to Tell
(a)	A is a non-metal.			
(b)	B can be magnetised.			
(c)	C is made of copper.			
(d)	Both B and C are good conductors of electricity.			

Rosyth School/ Continual Assessment 1/ Standard Science/ P6/ 2009

19. Siti poured some cold water in four cups of different materials. She placed the cups in the same place and observed the amount of water droplets formed on the outside of the cups over a period of 20 minutes.

She tabulated her results as shown below.

Material of cups	Observations
A	No water droplets formed.
B	A lot of water droplets formed.
C	Very few water droplets formed.
D	Some water droplets formed

- (a) State two other variables she must keep constant for the experiment to be fair. [1]
-
- (b) Which material (A, B, C or D) is the most suitable to make an ice-cream container? [1]
-

20. Dean made a toy tortoise using a polystyrene foam cup. He fixed a ball of plasticine to the rubber band inside the cup.

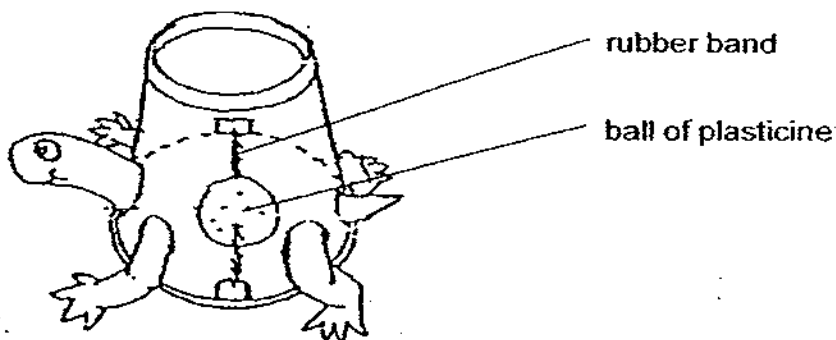

He placed the tortoise on the table and rolled it backwards. Then he released the tortoise and it was able to move on its own.

- (a) What was the energy source in this toy? [1]
-
- (b) He wanted to find out if kinetic energy will be affected by potential energy. What variable would he change for the above experiment? [1]
-
- (c) What variable would he measure to show that kinetic energy is affected by potential energy? [1]
-

Rosyth School/ Continual Assessment 1/ Standard Science/ P6/ 2009

21. A pendulum bob attached to a light string is released from rest at position P. It makes one complete oscillation from position P to S and back to P again.

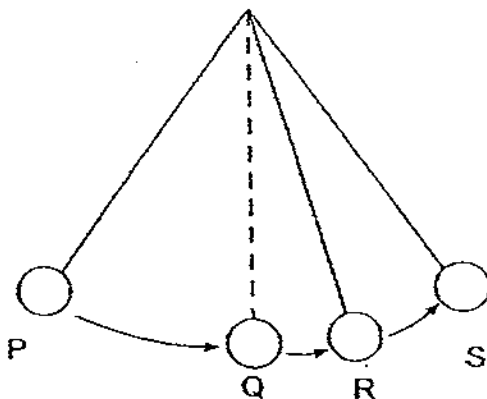

The change in kinetic energy of the bob from P to S is shown in the graph below.

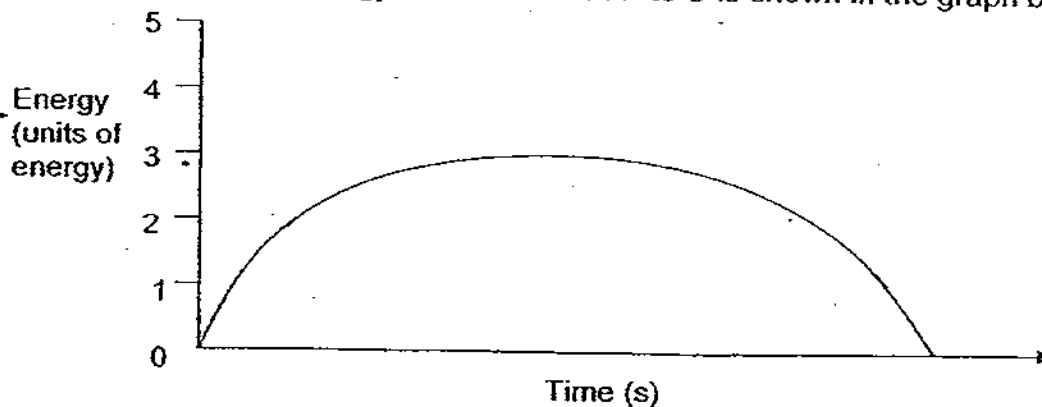

- (a) On the same axes, draw a graph to show the change in potential energy of the pendulum bob from P to S. [1]
- (b) State the types of energy possessed by the pendulum bob when it is at position R. [1]
-
- (c) State the conversion of energy as the bob moves from P to S in the boxes provided below. [1]

→ →

Rosyth School/ Continual Assessment 1/ Standard Science/ P6/ 2009

22. Evan had three dishes. He put some paper towels and 40 mustard seeds in each dish. He put one dish in the refrigerator, one dish in a dark cupboard and the last dish in a bright classroom. He watered the seeds regularly.

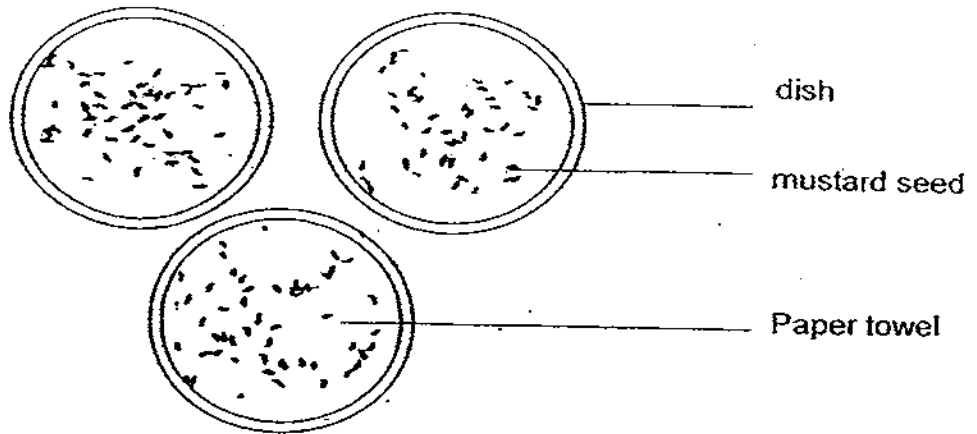

Evan counted the number of germinated seeds in the dishes each day and recorded the results as shown in the table below.

Place	Number of germinated seeds		
	Day 1	Day 2	Day 3
Refrigerator	0	0	0
Cupboard	0	25	40
Classroom	0	23	40

- (a) What is the aim of the investigation? [1]

- (b) What should he do to ensure that his results are reliable? [1]

Rosyth School/ Continual Assessment 1/ Standard Science/ P6/ 2009

23. The diagram below shows how plant X reproduces. The processes are labelled A to E.

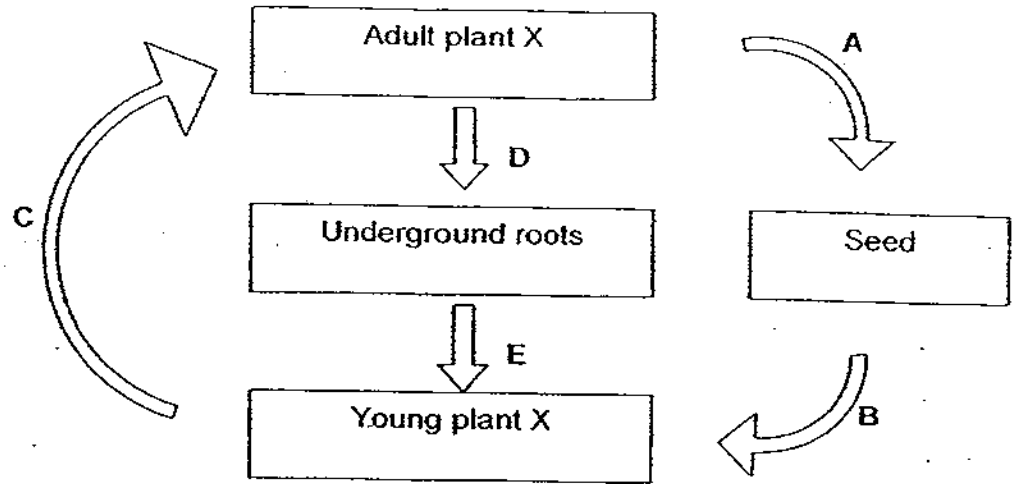

(a) Name the processes that would occur at stage A. [1]

(b) Give an example of a plant that could represent plant X. [1]

(c) Give reasons for your answer in (b). [1]

END OF PAPER



ANSWER SHEET

EXAM PAPER 2009

**SCHOOL : ROSYTH PRIMARY
SUBJECT : PRIMARY 6 SCIENCE**

TERM : CA1

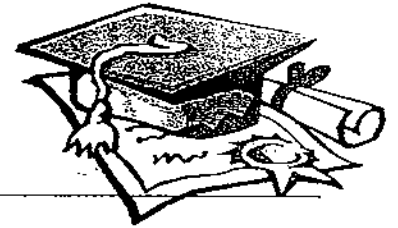

Q1	Q2	Q3	Q4	Q5	Q6	Q7	Q8	Q9	Q10	Q11	Q12	Q13	Q14	Q15
3	2	2	1	2	4	1	3	1	4	4	3	2	4	1

16)a)i)vertebrate ii)invertebrate iii)warm blooded
iv)cold blooded

17)a)It is a simple with tooth edge and Net vein leaf.

b)Galsam Flosam



18)a)Not b)T c)F d)T

19)a)Temperature of water thickness of cup.

b)Material A.

20)a)Stretched rubber band.

b)Number of rubber bands distance the tortoise is rolled backwards the number of times the rubber band is stretched.

c)The length of rubber band stretched.

21)a)

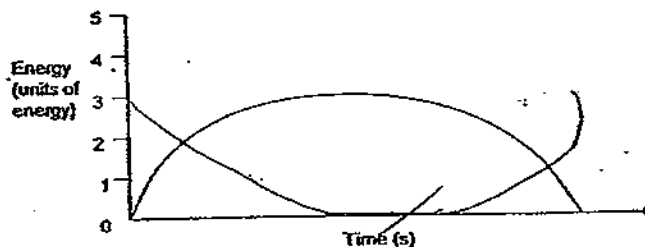

21)b)Kinetic energy and potential energy.

c)Potential energy→Kinetic energy→Potential energy.

22)a)To find out if germinating seeds need warm and light.

b)Repeat the experiment.

23)a)Pollination and Fertilization.

b)Carrot.

c)Carrot is grown by seed and is an underground roots.