



CATHOLIC HIGH SCHOOL  
PRELIMINARY EXAMINATION ONE

(2011)  
PRIMARY 6  
SCIENCE

Name: \_\_\_\_\_

Class : Primary 6\_\_\_\_\_

Date : 14 April 2011

BOOKLET A

30 Questions  
60 Marks

Total Time for Booklets A & B : 1 hour 45 minutes

**Instructions to Candidates**

Do not open this booklet until you are told to do so.  
Follow all instructions carefully.  
Answer all questions.

Section A: Multiple Choice Questions (60 marks)

For each question from 1 to 30, four options are given. One of them is the correct answer. Make your choice (1, 2, 3 or 4) on the Optical Answer Sheet.

1. Mr. Tan ~~wanted~~ to find out how much ~~food is digested~~ in the digestive system over a period of time.

Which one of the following axes should he use to show his results?

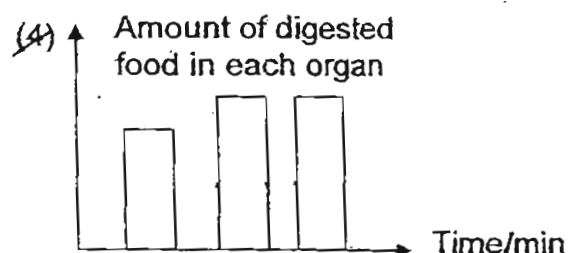
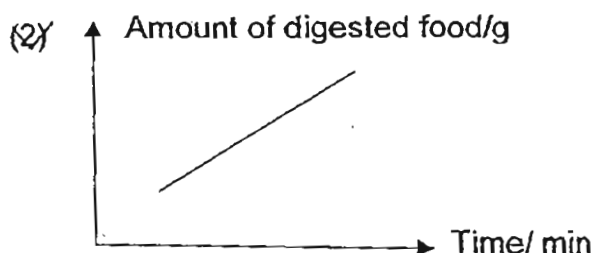
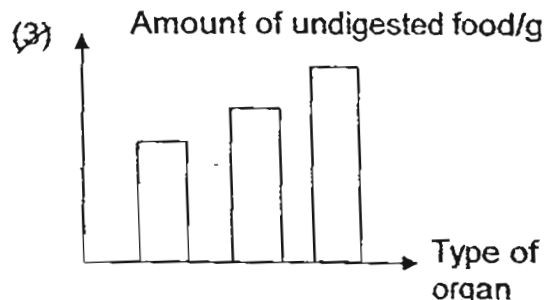
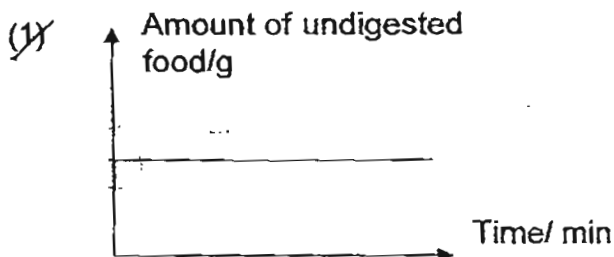

2. The diagram below shows the cross section of a plant. Irene wanted to find out whether Part X of the plant has a system to transport a substance to other parts of the plant. She did the following tests:

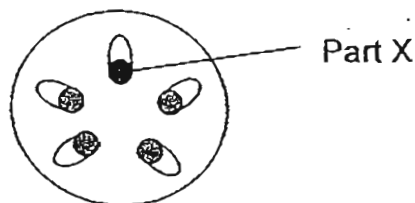

- A Wrap a plastic bag around the leaves of a plant and place it in the sunlight.
- B Conduct a starch test on the leaves.
- C Measure the amount of water taken in by the plants.
- D Conduct a starch test on other parts of the plant.
- E Place the plant in coloured water and find out if the leaves are stained.

Which of the following will help her to achieve the aim of her experiment?

- (1) B and D only
- (2) C and E only
- (3) A, C and E only
- (4) C, D and E only

3. The chart below shows how food and air is transported in the body.

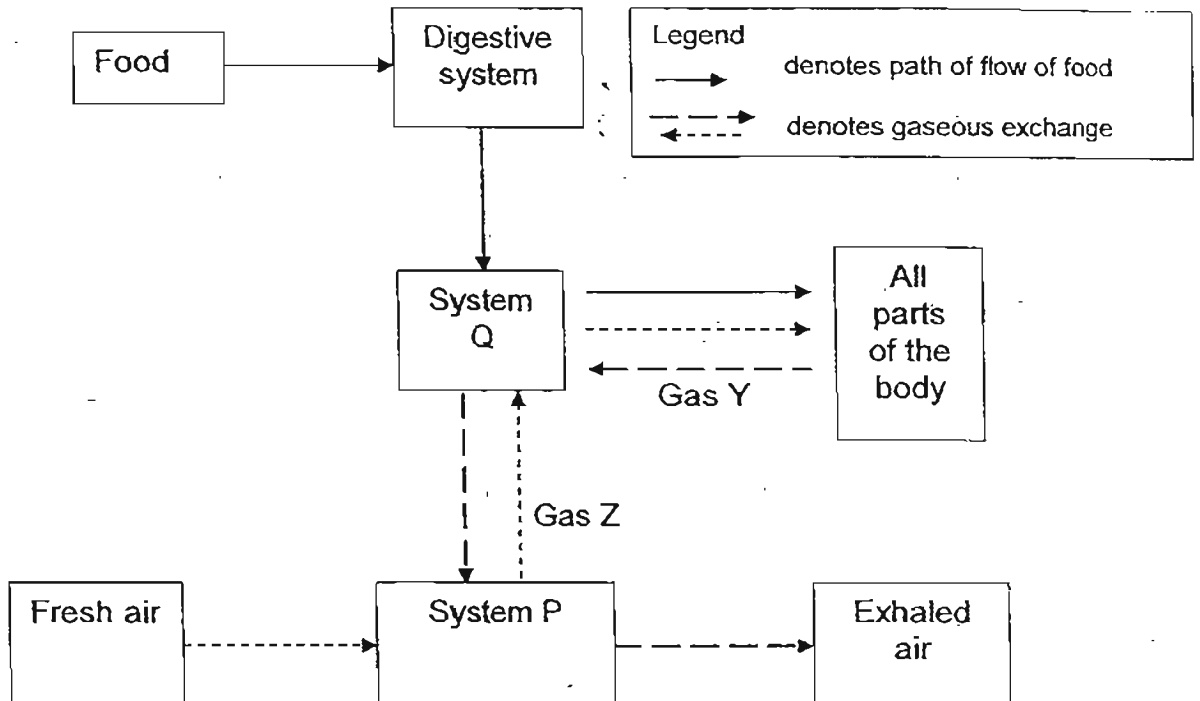

Identify Systems P, Q, R and Gases Y and Z.

	System P	System Q	Gas Y	Gas Z
(1)	Circulatory system	Respiratory system	Oxygen	Carbon dioxide
(2)	Respiratory system	Circulatory system	Oxygen	Carbon dioxide
(3)	Respiratory system	Circulatory system	Carbon dioxide	Oxygen
(4)	Circulatory system	Respiratory system	Carbon dioxide	Oxygen

4. Benedict set up a model of the respiratory system as shown below.

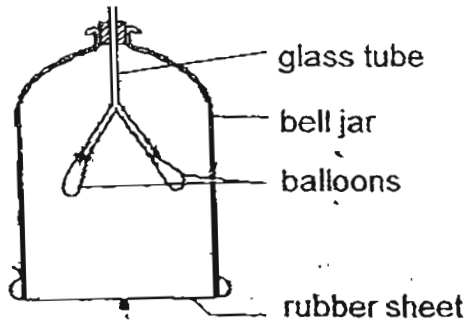

What would Benedict observe when he pulled down the rubber sheet?

	Balloons	Amount of air in the balloons
(1)	Deflated	More
(2)	Inflated	Less
(3)	Inflated	More
(4)	Deflated	Less

5. The diagram below shows a microscopic view of a part of the plant.

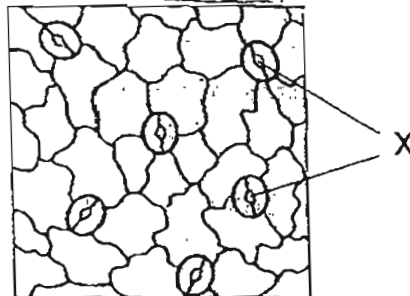

Which one of the following statements is true about the main function of the parts labelled X?

- (1) X makes food for the plant.
- (2) X absorbs sunlight for the leaf to make food.
- (3) X enables the leaf to take in water to make food.
- (4) X enables the leaf to exchange gases with its surroundings.

6. The diagram below shows how sugar and water are transported to and from different parts of the plant represented by A, B and C.

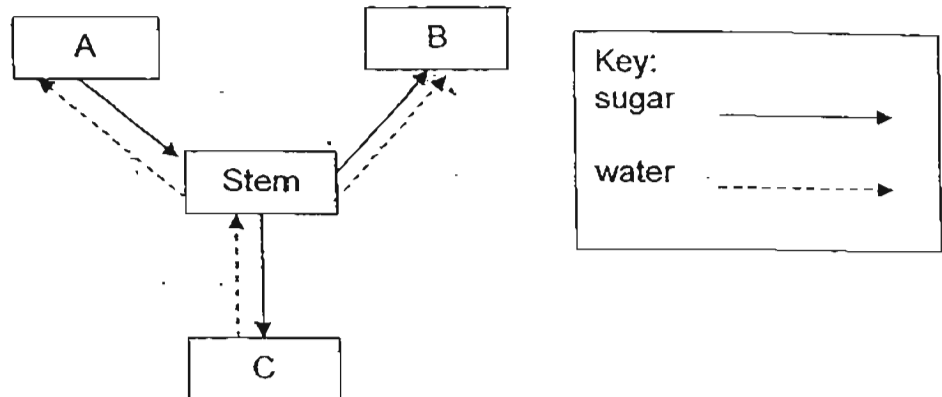

Which of the following parts of plant are best represented by A, B and C?

	A	B	C
(1)	flowers	leaves	roots
(2)	leaves	roots	fruits
(3)	roots	leaves	flowers
(4)	leaves	fruits	roots

7. The table below shows the parts of a cell. A tick (✓) in the boxes represents the part of a cell that Cells P, Q, R and S have.

Parts of a Cell	Cell P	Cell Q	Cell R	Cell S
Cytoplasm	✓	✓	✓	✓
Cell Membrane	✓	✓	✓	✓
Cell Wall		✓		✓
Nucleus	✓	✓		✓
Chloroplasts				✓

Based on the above information, which of the above cell(s) is/are plant cells?

- (1) S only  
 (2) Q and S only  
 (3) P and R only  
 (4) P, Q and R only

8. Arthur wanted to carry out an experiment to find out how a plant can disperse its seeds further. The diagram below shows how three similar fruits were used in the experiment.

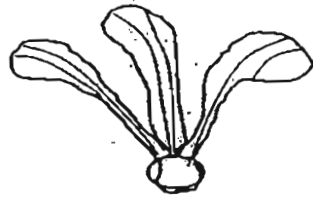

Left intact



1 wing is removed



2 wings are removed

Each of the three fruits was then released from a window ledge and the results were recorded:

What should Arthur record down in the above experiment?

- (1) Mass of the fruits
  - (2) Speed at which the fruit floated in the air
  - (3) Height at which each fruit was dropped
  - (4) Time taken for the fruits to reach the ground
9. Darren wanted to test if bees are attracted to the colour of flowers. Which one of the following pairs should he use?

(1)



white flower X with nectar



white flower Y with no nectar

(2)



yellow flower X with nectar



red flower Y with nectar

(3)



white flower X with nectar



yellow flower X with no nectar

(4)



white flower Y with nectar



red flower Y with nectar

10. Study the diagrams below carefully.

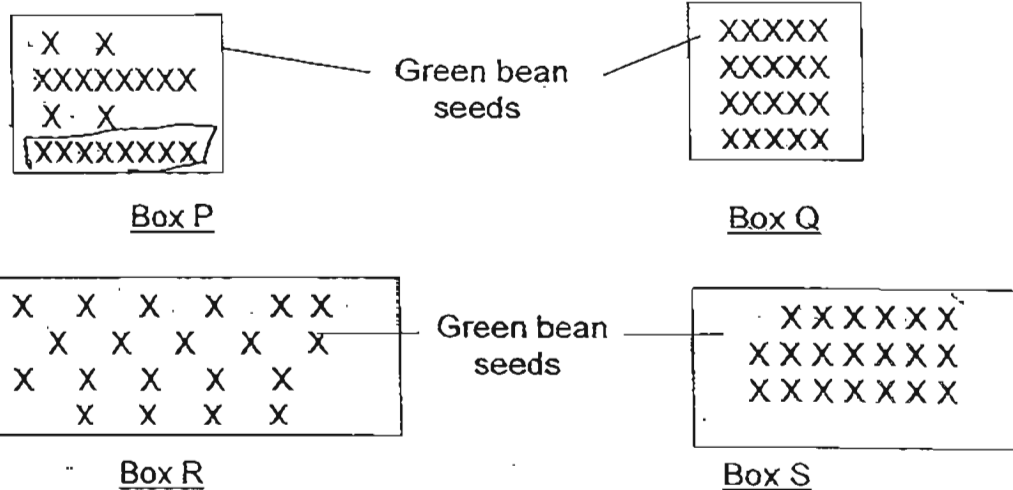

In the experiment shown above, four boxes were filled with soil and the same number of seeds was planted. Each box was watered with an equal amount of water each day.

Which one of the following about the plants in the set-ups is correct?

- (1) The plants in Box Q will grow the fastest.
- (2) The height of the plants in Box R will be the shortest.
- (3) The plants in Box P will grow better than those in Box S.
- (4) The height of those in Box S will be taller than those in Box P.

11. Si Jie planted some seeds from the same plant in 2 containers, A and B, as shown below. She only changed one variable in the experiment and the seeds germinated after a day.



Based on the above, which one of the following is most likely the variable that was being tested?

- (1) Presence of air
- (2) Presence of light
- (3) Amount of water
- (4) Type of petri dish

12. Human blood can be classified into four main blood types, A, B, AB and O.

The table below shows how each of these donor blood types can be matched to the recipient blood type.

Blood Types	Donor Blood Types			
	A	B	AB	O
Recipient Blood Type				
A	Yes	No	No	Yes
B	No	Yes	No	Yes
AB	Yes	Yes	Yes	Yes
O	No	No	No	Yes

Ron's family has the following blood types.

Father	Type B
Mother	Type AB
Ron's sister	Type A
Ron	Type B
Ron's brother	Type O

If Ron needs a blood transfusion, who can he receive blood from?

- (1) His sister only.
- (2) All except his sister.
- (3) His mother and father only.
- (4) His father and brother only.



13. A group of pupils carried out an investigation on photosynthesis. They left 3 similar pots of plants in a dark room for 3 days and watered them daily. They then placed the pots of plants in the 3 set-ups shown below. These pots were then placed under the sun in the school field.

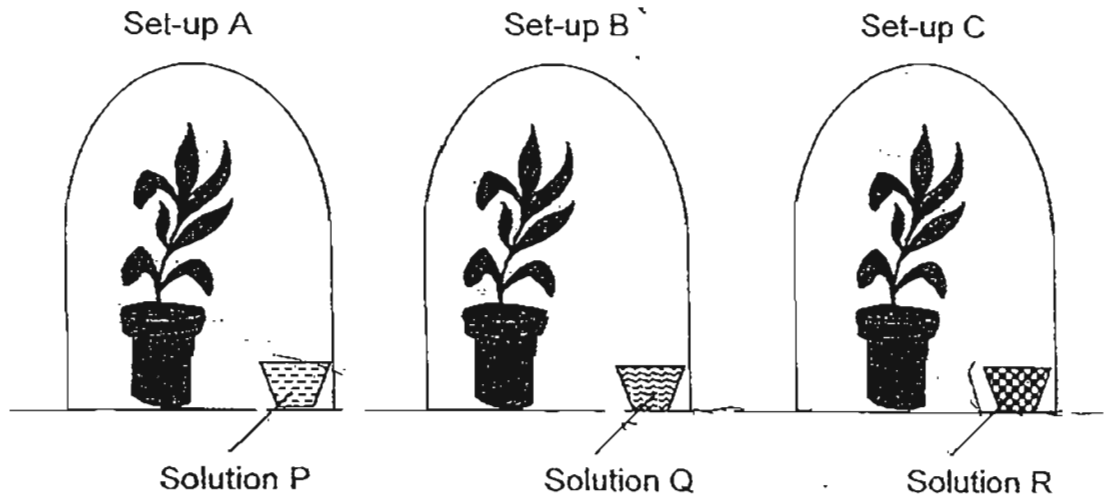

After 5 hours, the pupils removed a leaf each from the set-ups, A, B and C and labelled them as A, B and C. They then conducted a starch test on each of them and the results were as follows.

Leaf	Observation
A	Iodine remained brown.
B	Iodine turned dark blue.
C	Iodine turned dark blue.

Which one of the following was most likely to be the purpose of solutions P, Q and R?

	Solution P	Solution Q	Solution R
(1)	Removes oxygen	Removes water vapour	Absorbs oxygen
(2)	Removes carbon dioxide	Produces carbon dioxide	Absorbs water vapour
(3)	Removes water vapour	Removes oxygen	Absorbs carbon dioxide
(4)	Produces carbon dioxide	Removes carbon dioxide	Absorbs oxygen

14. The diagram below shows a bottle garden.

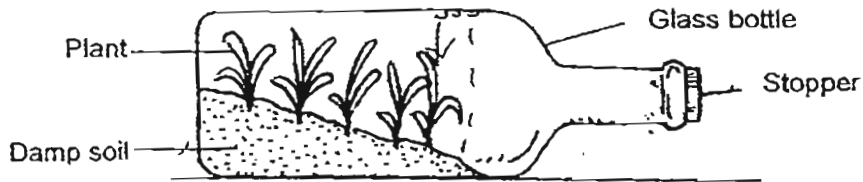

It was placed in the Science room under a lamp that was switched on. It was left unattended for a week.

Which one of the following observations best describes what happens after a week?

- (1) Without sunlight, the plants will not be able to make their own food.
- ~~(2)~~ The plants will have a continuous supply of water to enable them to survive.
- ~~(3)~~ The plants will have wilted as they would have used up all the water in the soil.
- (4) There is insufficient carbon dioxide for the plants to make food so the plants would have withered.

15. Sally conducted an experiment with 4 identical iron nails, W, X, Y and Z to find out how the number of strokes made by a magnet would affect the magnetic strength of an iron nail. She stroked each nail with a magnet in the same direction as shown below.

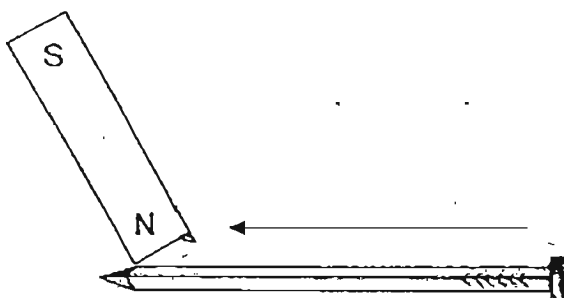

She counted the number of times she stroked each nail with the magnet. She then tested each magnetised nail by holding it close to some pins. She counted the number of pins attracted to each magnetised nail and recorded her results in the table below.

Nail	Number of strokes	Number of pins attracted by magnetised nail
W	40	10
X	30	8
Y	20	6
Z	10	4

From the table above, which one of the following statements is false?

- (1) If Nail Y received more strokes, it can attract only 6 pins.  
 (2) Nail W has become the strongest magnet after stroking it 40 times with a magnet.  
 (3) An iron nail can become a magnet after stroking it with a magnet 10 times.  
 (4) The number of pins picked up by a magnetised nail is dependent on the number of times the nail was stroked with a magnet.
16. Three identical syringes were filled with an equal amount of A, B and C. The plunger was then pushed in with a similar force and the distance moved by the plunger was recorded in the table as shown below.

Substance	Distance moved by the plunger when pushed in/cm
A	0
B	0
C	4

Which one of the following statements about the substances is definitely true?

- (1) A and B can be solids.  
 (2) C has a definite volume.  
 (3) C cannot be compressed.  
 (4) B does not take the shape of the container.

17. The diagram below shows a piece of cork floating in a trough of water.....

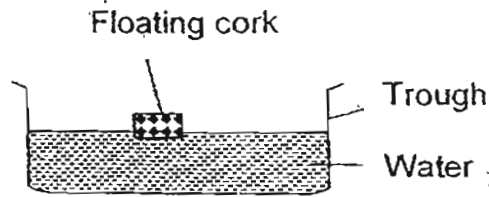

An empty plastic cup is inverted over the cork carefully and held down firmly into the trough of water.

Which one of the diagrams above shows the most possible position of the cork in the plastic cup?

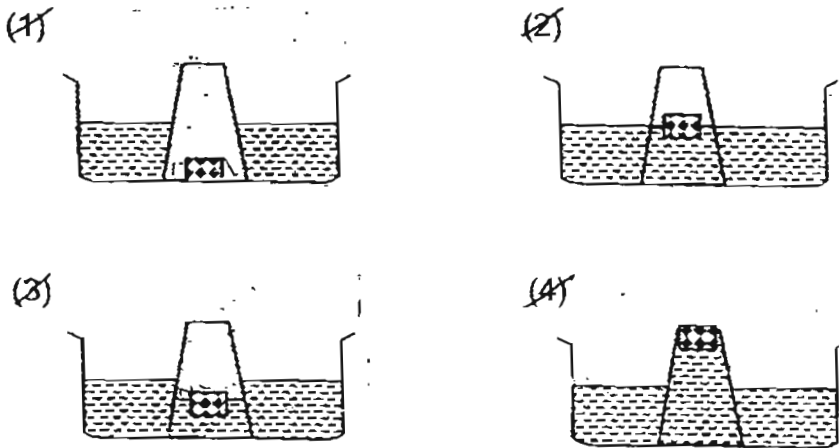

18. Study the water cycle below.

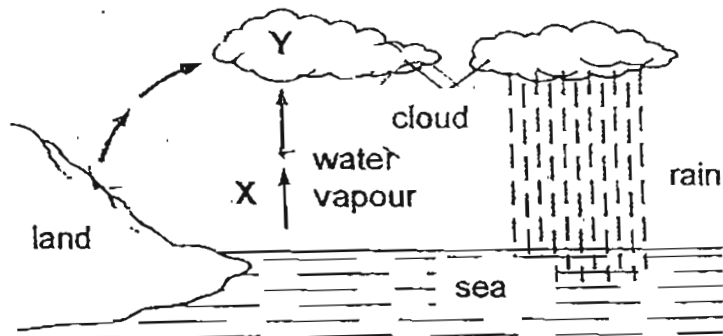

Which of the following correctly describes the processes X and Y in the diagram above?

- A Process X does not take place at a fixed temperature.
- B Process X takes place at a higher temperature than Y.
- C Process Y takes place only when there is a warmer surrounding air.

- (1) A and B only
- (2) A and C only
- (3) B and C only
- (4) A, B and C

19. Wendy poured  $100 \text{ cm}^3$  of water into each of the four bowls A, B, C and D. The four bowls were made of the same materials but have different exposed surface areas. She placed three of the bowls on a table in the open and another under direct sunlight.

A few hours later, she measured the volume of water left in each bowl using a measuring cylinder as shown below.

	Bowl W	Bowl X	Bowl Y	Bowl Z
Exposed surface area/ $\text{cm}^2$	20	40	60	80
Volume of water remaining/ $\text{cm}^3$	64	73	70	64

Which one of above bowls was most likely left in a different location from the rest?

- (1) Bowl W
- (2) Bowl X
- (3) Bowl Y
- (4) Bowl Z

20. Study the flow chart below.

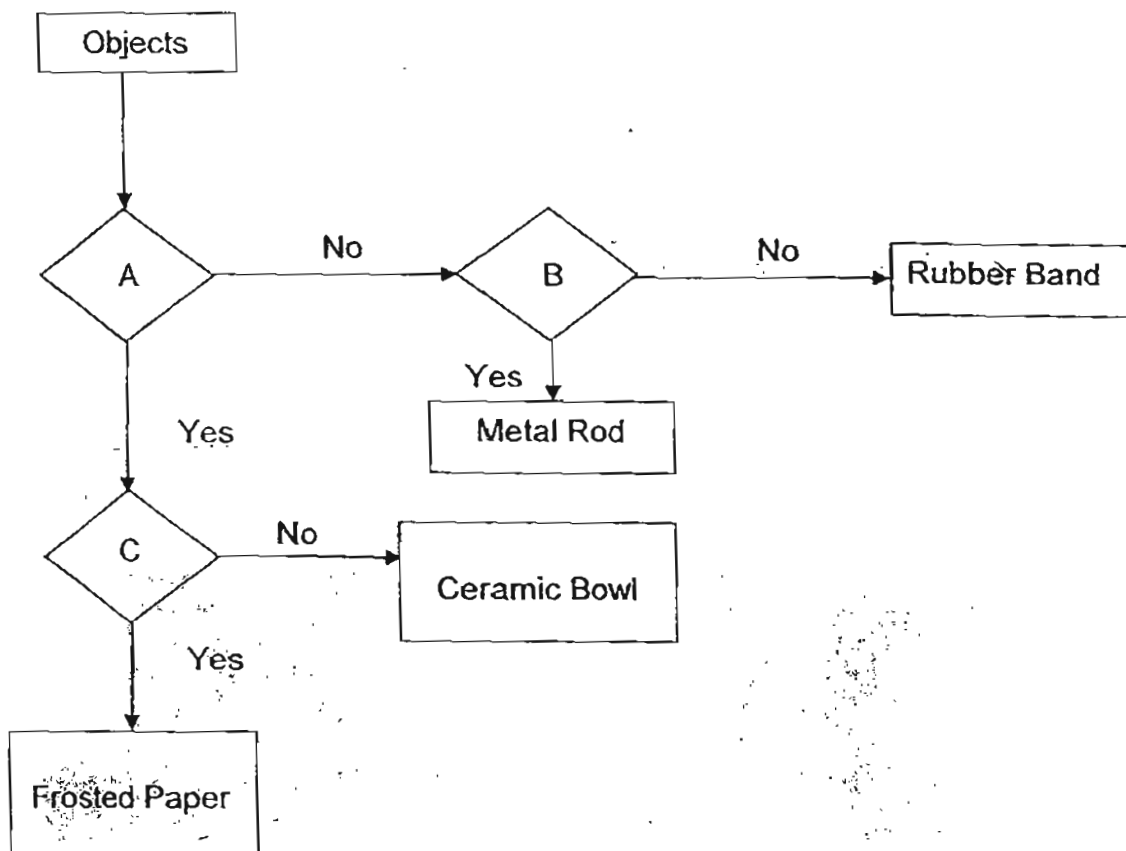

Which of the following correctly fits into A, B and C?

	A	B	C
(1)	Allows light to pass through?	Can be stretched?	Breaks easily?
(2)	Breaks easily?	Conducts electricity?	Allows light to pass through?
(3)	Can be stretched?	Breaks easily?	Allows light to pass through?
(4)	Breaks easily?	Conducts electricity?	Can be stretched?

21. The diagram below shows two cubes that are attached together.

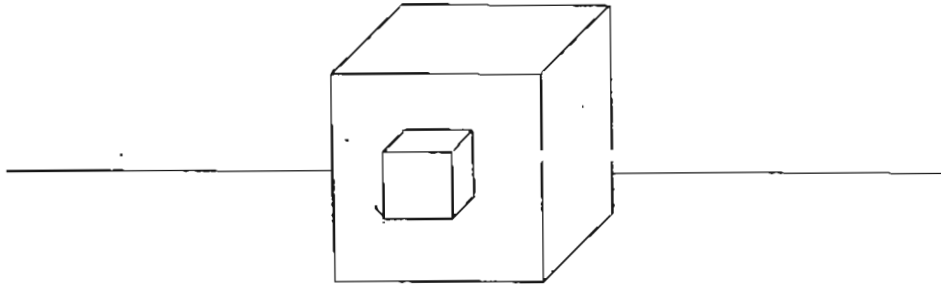

A light source was shone from different positions on the two cubes which are mounted on the table.



Which of the following could be the shadow(s) cast by the two cubes?

- (1) C only
- (2) A and C only
- (3) B and D only
- (4) B, C and D only

22. Sharon poured an equal amount of water but of different temperatures into two similar containers, A and B. Each contained an equal amount of milk powder as shown below.

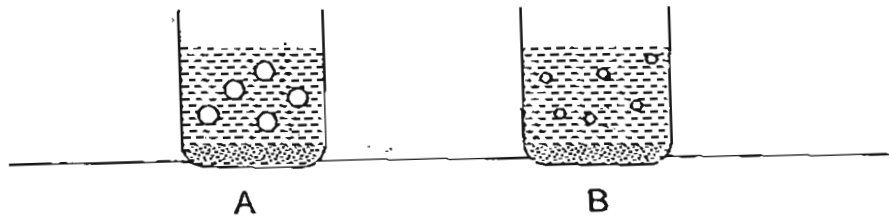

She observed that the bubbles in A were bigger than those in B.

Based on the observations above, which one of the following is correct?

	Temperature of water poured into A/°C	Temperature of water poured into B/°C	Explanation
(1)	80	45	Heat caused the hot water in A to expand more than in B.
(2)	45	80	The heat caused the milk powder to expand lesser in B, thus the bubbles are smaller.
(3)	80	45	Heat caused the dissolved air in the milk powder and water in A to expand more than in B.
(4)	45	80	Heat caused A to expand more than B.



23. Rachel carried out an investigation to test the electrical conductivity of four different materials, A, B, C and D in an electrical circuit shown below.

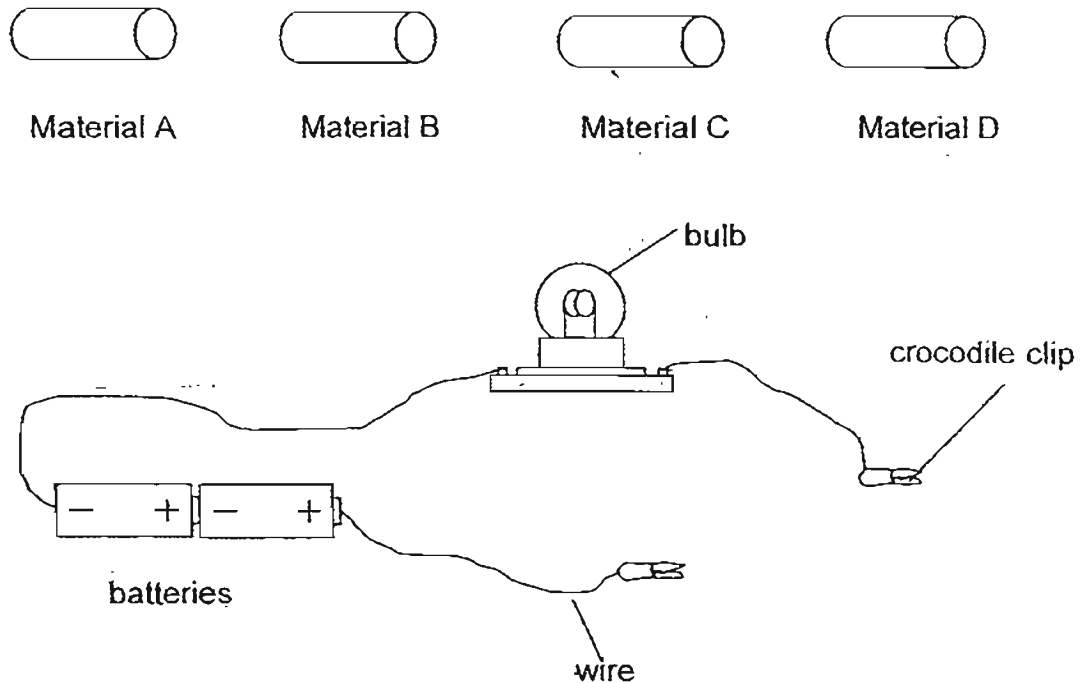

If the material is a conductor of electricity, the bulb in the set-up lights up. Rachel recorded the results in the table shown below.

Material	Does the bulb light up?
A	No
B	Yes
C	No
D	Yes

Which of the following shows the materials which the objects A, B, C and D are made of?

	A	B	C	D
(1)	steel	iron	paper	fabric
(2)	fabric	ceramic	plastic	carbon
(3)	copper	steel	glass	ceramic
(4)	ceramic	iron	rubber	copper

24. The list below shows some processes involving energy changes.

- A Burning of oil
- B Rubbing of two bottle caps together
- C A stone falling off a cliff
- D A moving windmill connected to an electric generator.

Which one of these diagrams correctly shows the energy changes in the processes above?

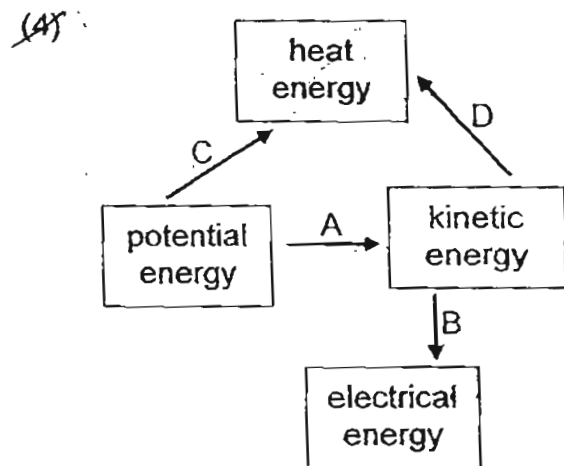
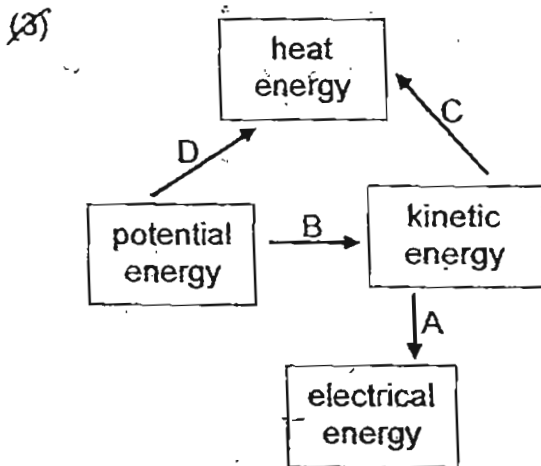
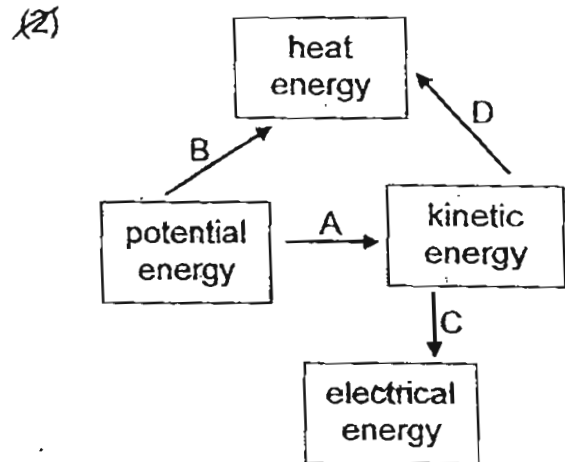
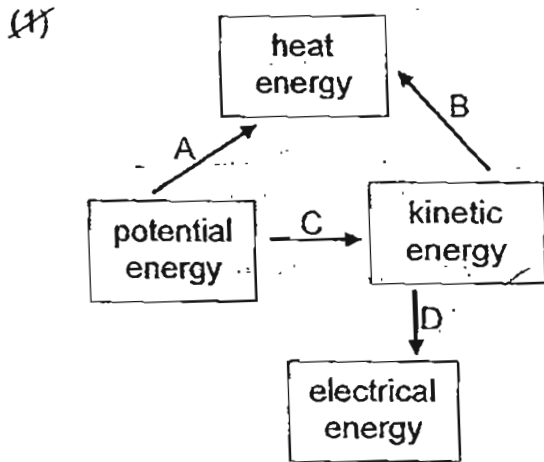

25. The diagram below shows a boy on a swing.

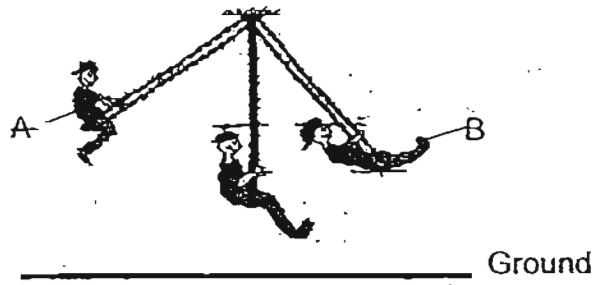

Which one of the following graphs correctly shows the changes in the amount of potential energy and kinetic energy from position A to position B?

Kinetic energy	-----	Gravitational Potential energy	—————
----------------	-------	--------------------------------	-------

~~(1)~~

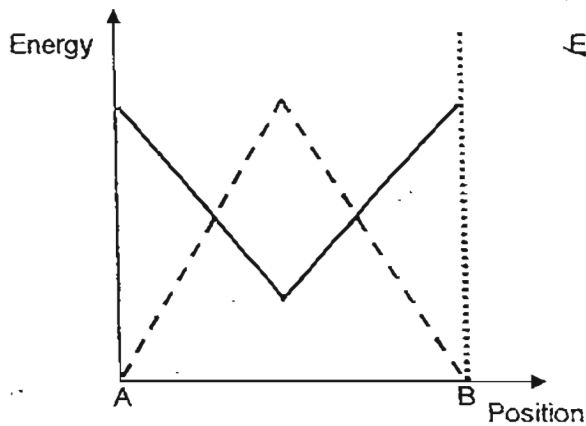

~~(2)~~

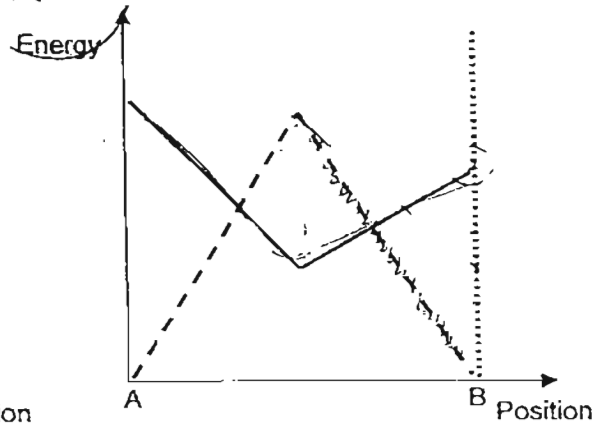

~~(3)~~

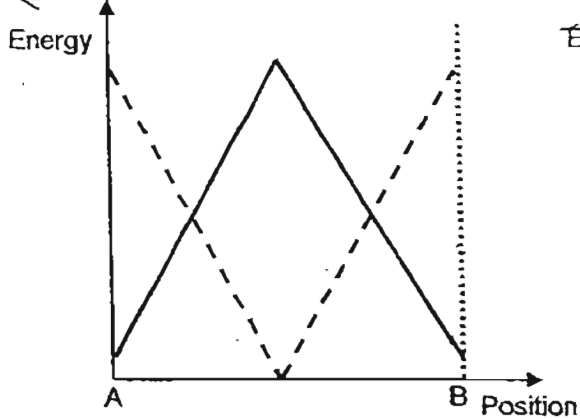

~~(4)~~

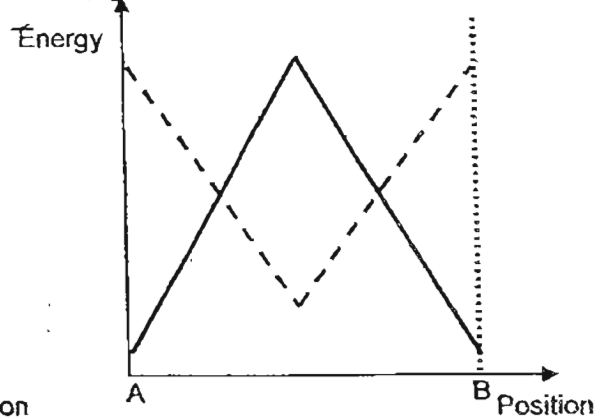

26. Look at the diagram below carefully.

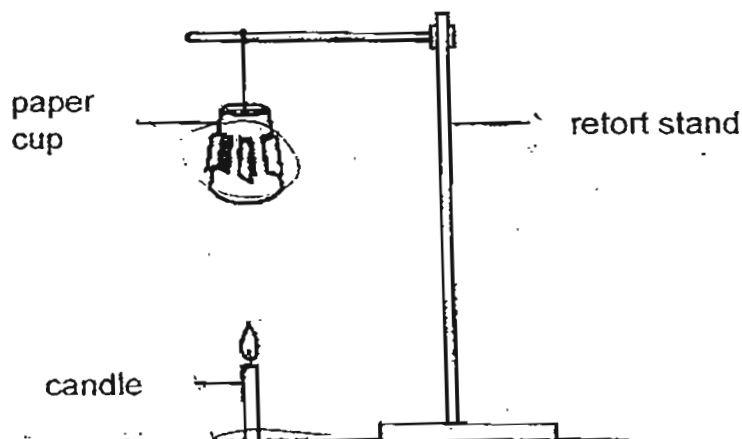

What energy conversion took place to make the paper cup spin?

- (1) Heat Energy  $\rightarrow$  Kinetic Energy + Light Energy
- (2) Heat Energy + Light Energy  $\rightarrow$  Kinetic Energy
- (3) Potential Energy  $\rightarrow$  Light Energy + Heat Energy  $\rightarrow$  Kinetic Energy
- (4) Potential Energy  $\rightarrow$  Heat Energy + Light Energy + Kinetic Energy

27. Janice can reach the second floor of a shopping centre from the first floor by climbing a flight of stairs or by using the nearby elevator.



Which of the following statement(s) is/are correct?

- A She does not gain gravitational potential energy by climbing the stairs.
- B She uses more chemical potential energy to climb the stairs than taking the elevator.
- C She gains more gravitational potential energy by climbing the stairs than taking the elevator.
- D The gravitational potential energy she gained is the same whether she climbs the stairs or takes the elevator.

- (1) B only
- (2) B and D only
- (3) A and C only
- (4) A, B and D only

28. In the experiment shown below, weights were added until the wooden block began to move over the Surface W.

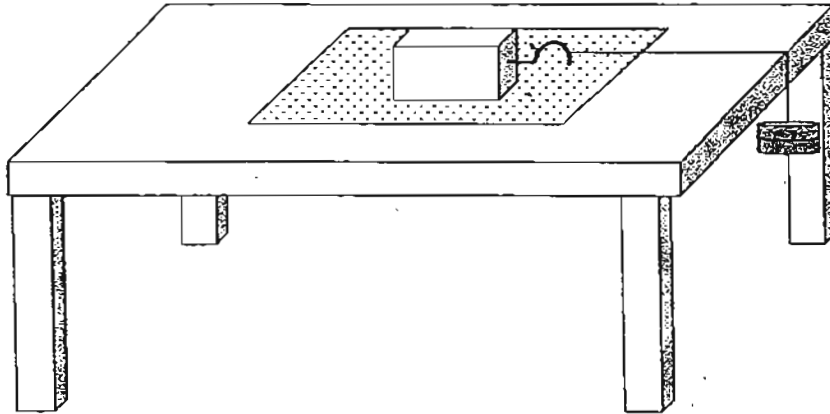

The experiment was repeated by replacing Surface W with different surfaces X, Y and Z.

The results are shown in the table below.

Type of surface	W	X	Y	Z
Force/required/unit	150	130	120	115

What can we conclude from the experiment?

- (1) It is easier to pull an object across Surface X than Surface Y.
- (2) Surface Y has the least frictional force as compared to Surface W, X and Z.
- (3) Surface Z is the most slippery and is most suitable for making a dance floor.
- (4) The wooden block has the greatest amount of frictional force when in contact with Surface W as compared to Surfaces X, Y and Z.

29. The graph below shows the length of a spring when different weights are attached to it.

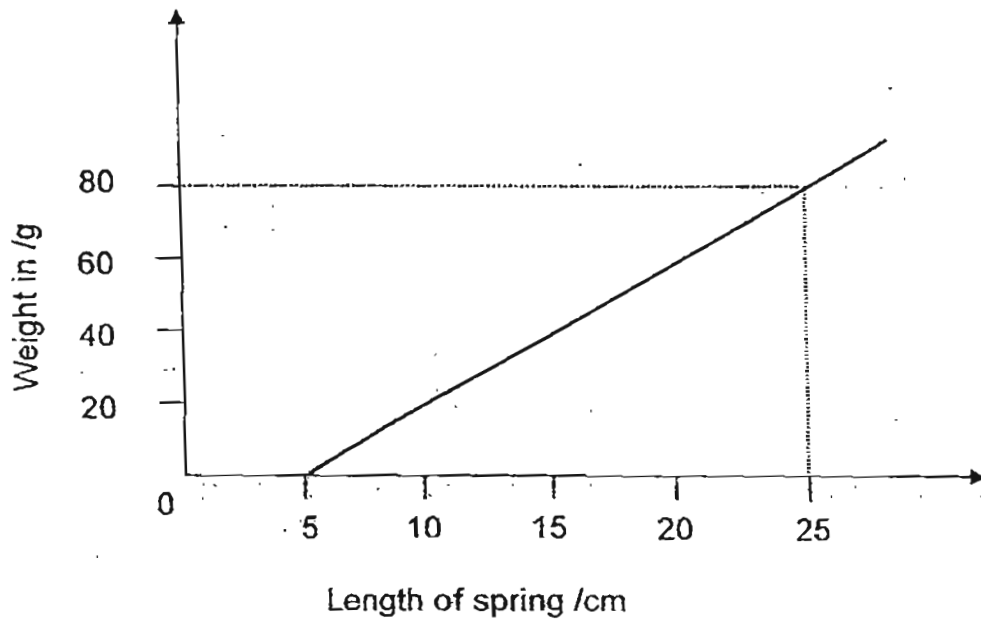

What was the extension of the spring when a weight of 80 g was attached to it?

- (1) 5 cm
- (2) 15 cm
- (3) 20 cm
- (4) 25 cm

30.

The diagram below shows a spring board. A ball was dropped from different heights onto end P and the maximum height to which the ball bounced was recorded. The experiment was repeated several times.

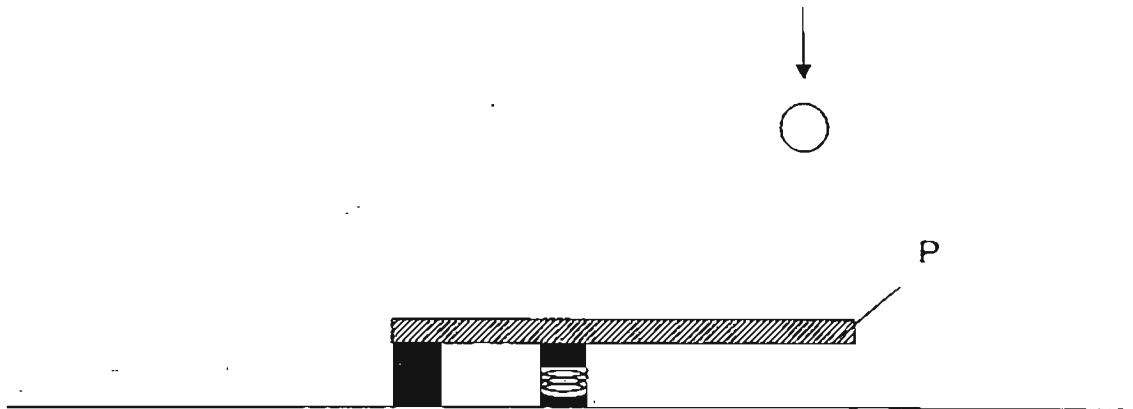

Which one of the following shows a possible aim of the experiment and the variables which should be kept constant? A tick indicates that the variable is kept constant.

	Aim of experiment	Position of spring	Length of wooden board	Distance between the ball and springboard
(1)	How the position of the spring affects the height that the ball bounce	✓		✓
(2)	How the number of springs affects how high the ball bounce	✓	✓	
(3)	How different heights the ball were dropped affected the height it bounced	✓	✓	
(4)	How the height that the ball was dropped affected how far it rolled		✓	✓

- End of Section A -



**CATHOLIC HIGH SCHOOL  
PRELIMINARY EXAMINATION ONE**

**(2011)  
PRIMARY 6  
SCIENCE**

Name: \_\_\_\_\_

Class : Primary 6 | \_\_\_\_\_

Date : 14 April 2011

**BOOKLET B**

14 Questions  
40 Marks

Total Time for Booklets A & B: 1 hour 45 minutes

**Instructions to Candidates**

Follow all instructions carefully.  
Answer all questions.

Parent's Signature: \_\_\_\_\_

Date: \_\_\_\_\_

Score	
Section A	60
Section B	40
Total	100



Section B: Open-ended Questions (40 marks)

Read the following questions carefully and write your answers in the space provided. The maximum marks that can be awarded are shown at the end of each question or part-question.

31. Zheng Wei was asked to jog around the track for ten minutes. His breathing rate and heartbeat rate during the activity were measured and plotted into line graphs as shown below.

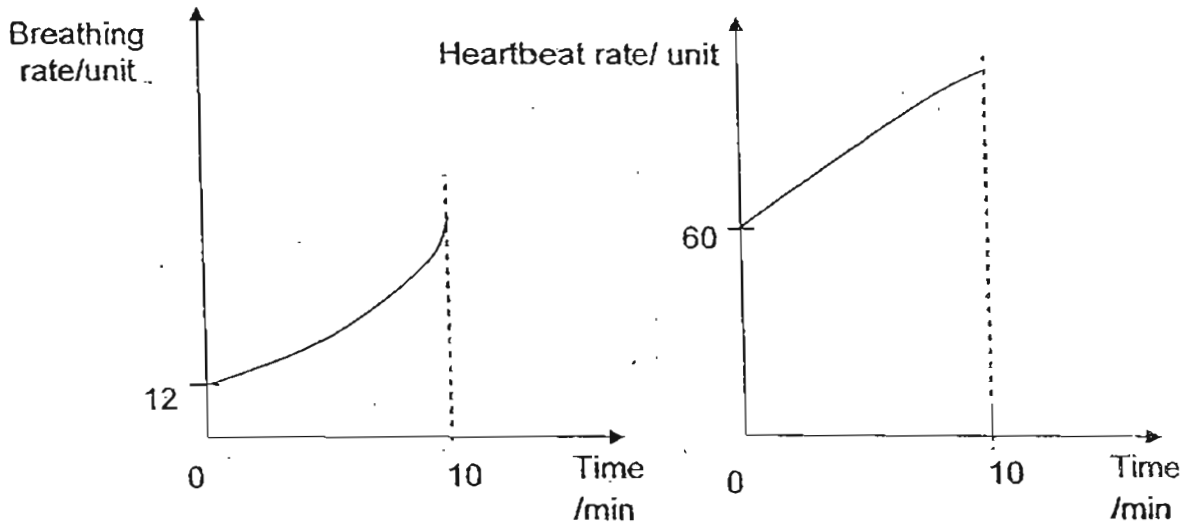

- (a) Based on the graphs shown above, what is the relationship between the breathing rate and the heartbeat rate?

[1]

- (b) After the 10-minute jog, Zheng Wei walked for another 10 minutes, before resting for the last 10 minutes.

Complete the graph below to show how his heartbeat rate will be for the 30 minutes of activities.

[1]

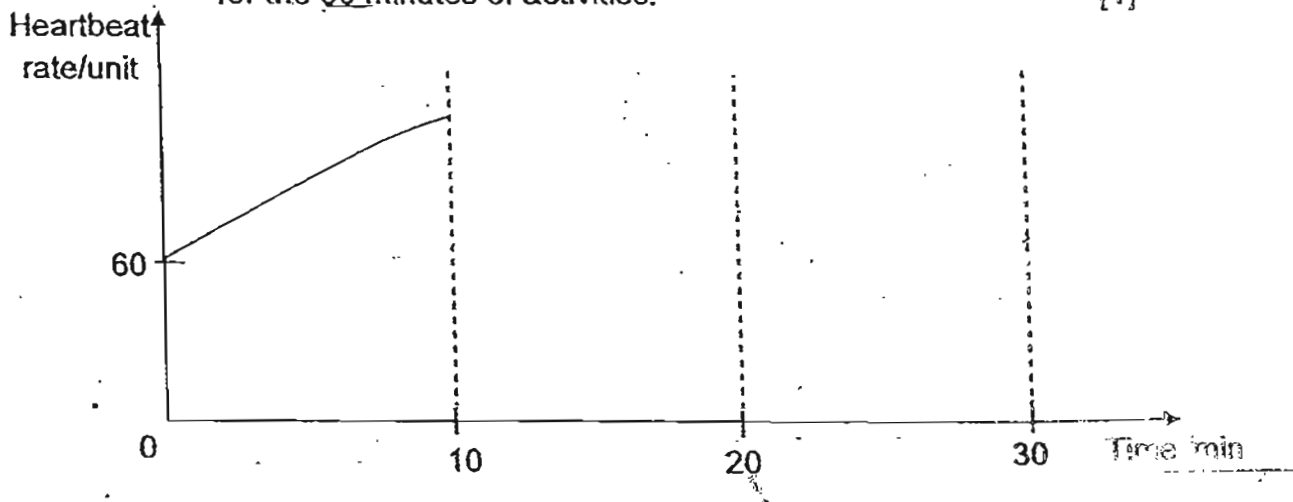

32. The diagrams below show the simplified human and fish circulatory systems. The arrows show how air is taken in by the respiratory systems and circulated in the bodies.

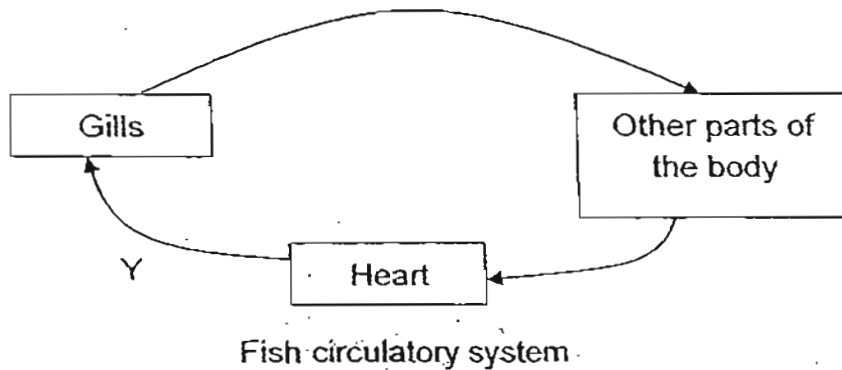
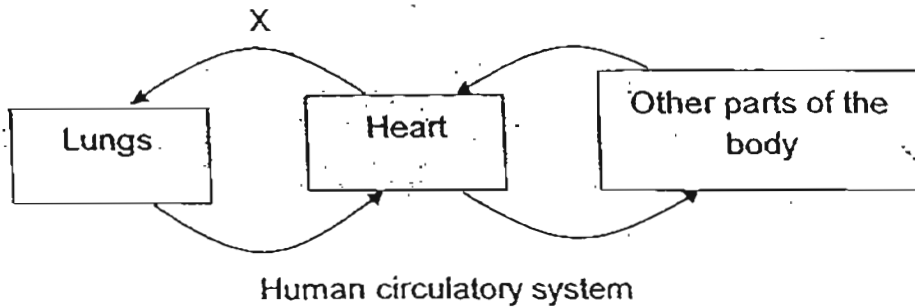

- (a) State the difference between how air is circulated in the systems based on the given diagrams above.

[1]

---



---

- (b) What is one similarity between the blood found at locations X and Y?

[1]

---

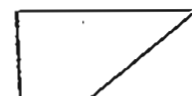

33. The diagrams below show a female cell and a male cell of a bird.

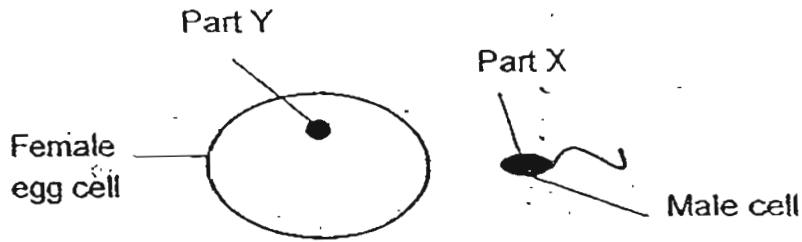

(a) What is the similarity between the parts of the cell labelled X and Y? [1]

---

(b) What happens during fertilization? [1]

---



---

34. Study the graph below.

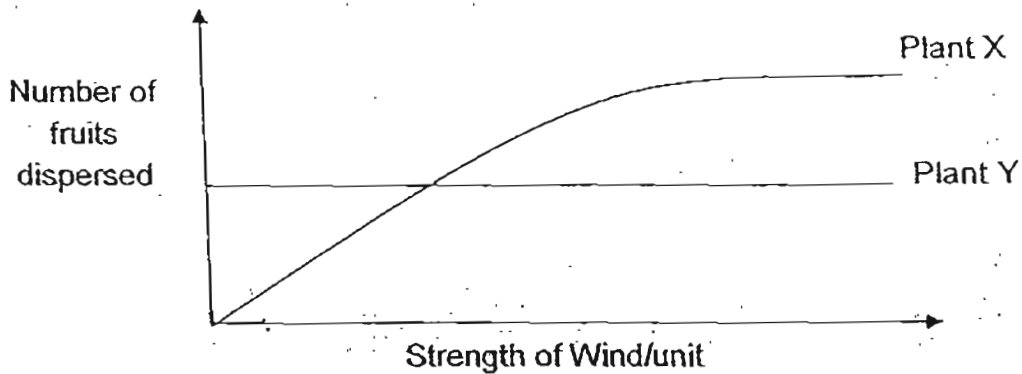

(a) Based on the graph above, how are the number of fruits dispersed by Plant X and Plant Y affected by the strength of the wind? [2]

---



---

(b) What can you infer about the structure of the fruits of Plant X based on the graph? [1]

---



35. Anders wanted to find out how the number of leaves on the plant affects the rate of absorption of water by the plant. He conducted an experiment by placing two similar plants in identical jars, each containing water at the same height  $h_1$  and  $h_2$ , as shown below.

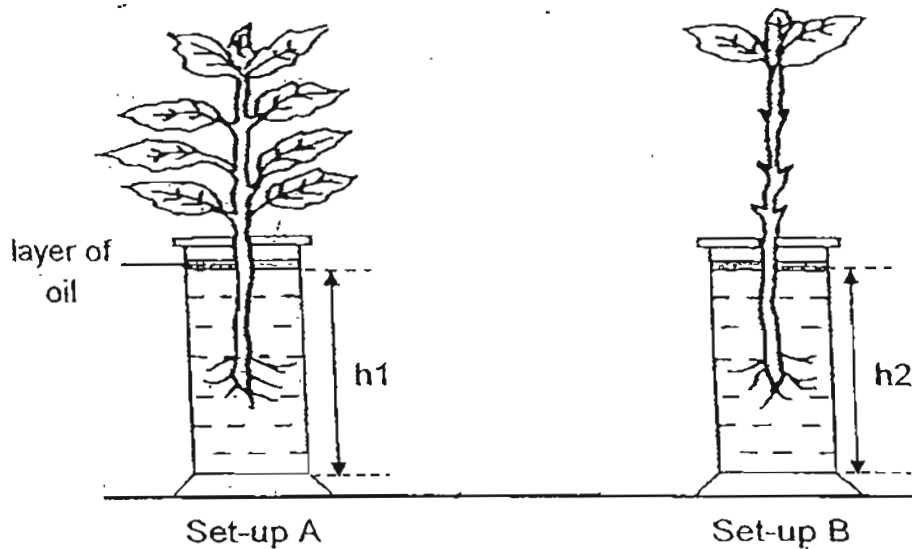

He then placed the two set-ups A and B next to the window for 2 days.

- (a) Draw the control for the experiment and label your diagram clearly. [2]

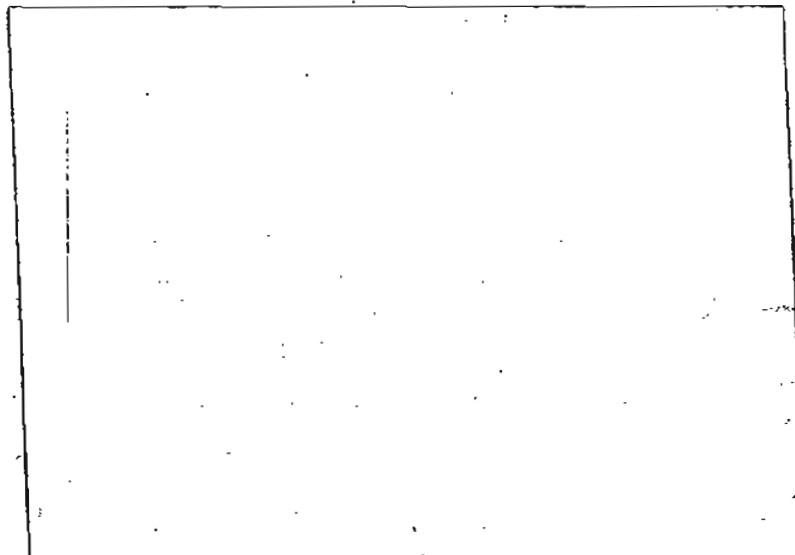

- (b) What should he observe in the both set-ups to conclude that the number of leaves on the plant affects the rate of absorption of water by the plant? [1]

36. An experiment was conducted by Sam using 2 similar leaves from land plants, A and B.

He coated the two leaves on different surfaces with oil. Each leaf was weighed and hung in an open area as shown below. After three hours, each leaf was weighed again.

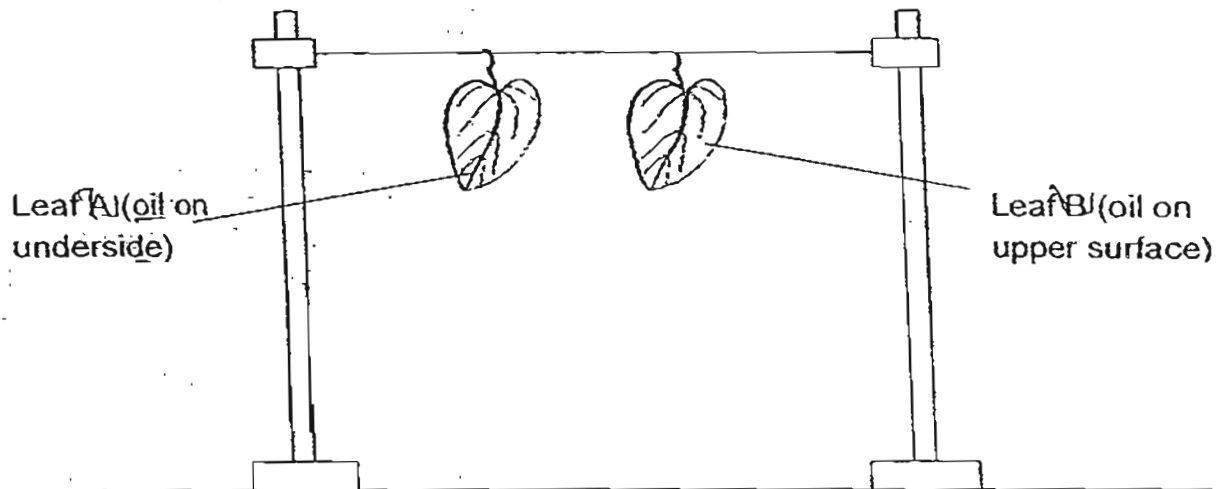

(a) What is the difference that will be observed in the mass of the two leaves after 3 hours? [1]

---

(b) Explain your answer in (a). [2]

---

---



37. Tim carried out an experiment by placing Bags A and B which contained starch solution into beakers filled with a brown solution X as shown in Set-ups 1 and 2 respectively.

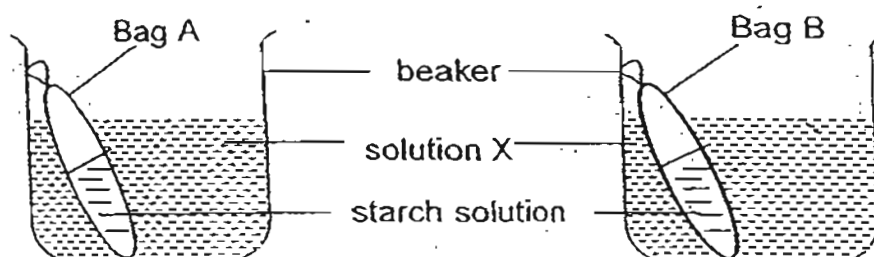

After an hour, he tested for the presence of starch at the end of the experiment in the respective bags and beakers in both set-ups. He recorded the results of his test in the table below.

Set-up 1	Colour of solution at the start of experiment	Colour of solution at the end of experiment
Solution in Bag A	White	Dark blue
Solution X in beaker	Brown	Brown

Set-up 2	Colour of solution at the start of experiment	Colour of solution at the end of experiment
Solution in Bag B	White	White
Solution X in beaker	Brown	Brown

- (a) What can Solution X be? [1]

---

- (b) Based on the given results, what can you conclude about the property of Bag A and Bag B from the above experiment? [1]

---

- (c) Explain your answer clearly in (b). [1]

---



---

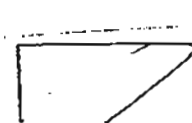

38. Arthur wanted to find out if he could magnetise two similar steel rods, X and Y, by using different poles of two magnets to stroke the rods. The diagrams below show the two ways that he stroked the steel rods.

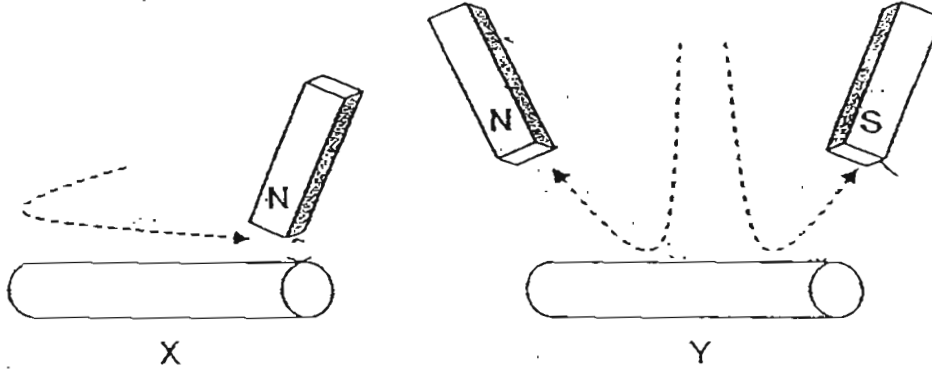

- (a) What will happen when both the steel rods are brought near some paper clips after they have been stroked? [1]

- (b) Explain how you will confirm if they have become temporary magnets. [1]

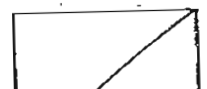

39. Mary covered the front of a plastic syringe with black paper and filled it completely with Matter X as shown below. She then puts weights on the plunger of the syringe. For every weight she added, she noted the volume of Matter X in the syringe.

The results are recorded in the table below.

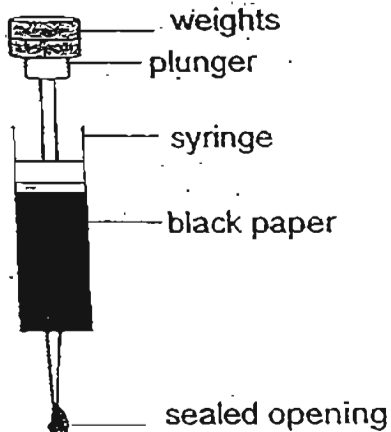

Weight added/g	Volume of MatterX /ml
0	50
1	45
2	40
3	36
4	32
5	26

- (a) What is the relationship between the number of weights added and the volume of Matter X in the plastic syringe? [1]

- (b) What can she conclude about Matter X? [1]

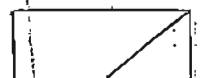



40. Judy walked from point A to C passing a lamp post at B.

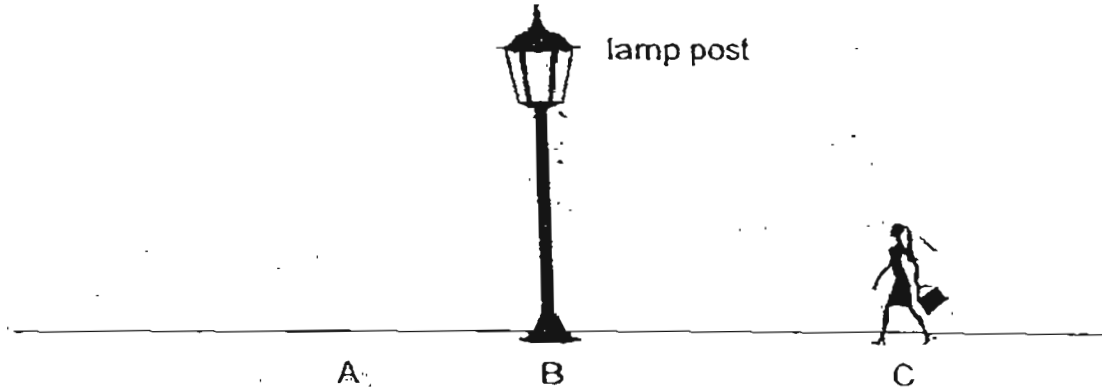

(a) If the only light source nearby was a lamp post, draw in the graph provided below to show how the length of her shadow changes from A to C. [1]

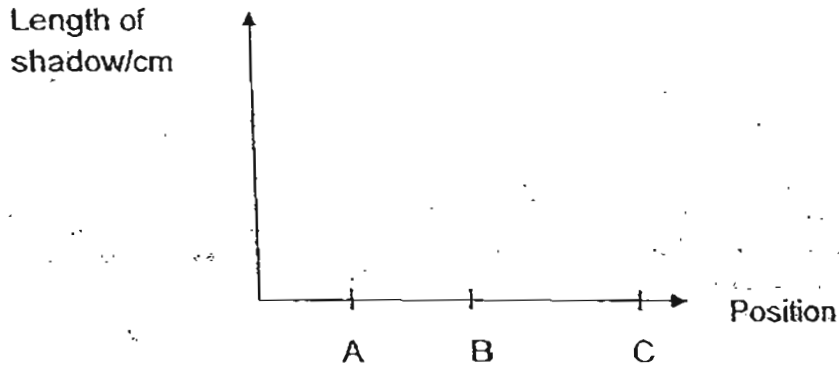

(b) Explain the change in the length of the shadow as shown in your graph. [2]

---

---



21. The rear window of the car shown below contains a heating element.

The heating element is part of an electrical circuit connected to the battery of the car.

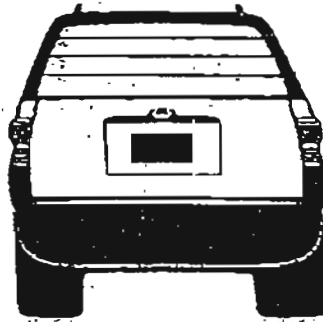

The diagrams below show two ways of connecting the circuit of a heating element.

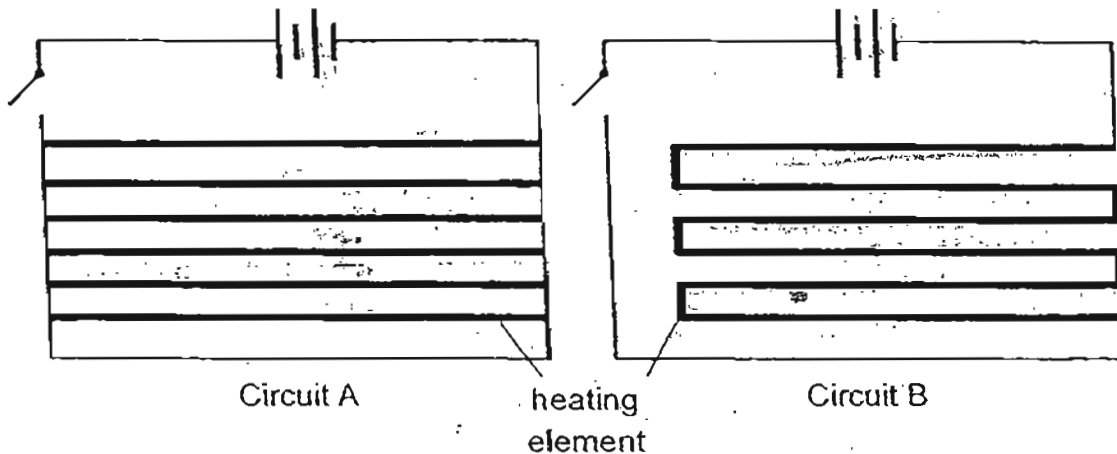

- (a) Which of the above circuits, A or B, should be used for the circuit of the heating element? Do not use the length of the heating element as a reason for your choice. Explain your answer. [2]

---

---

- (b) What is one difference between the two circuits when the switches for both the circuits are closed? State one disadvantage of Circuit A as compared to Circuit B. [2]

---

---

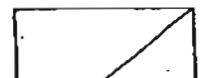

42. Aaron left three similar glass blocks in 3 rooms of different temperatures for an hour. They were then removed and left in Room D. After a few minutes, he observed water droplets on the block from Room A but not the blocks from Room B or C.

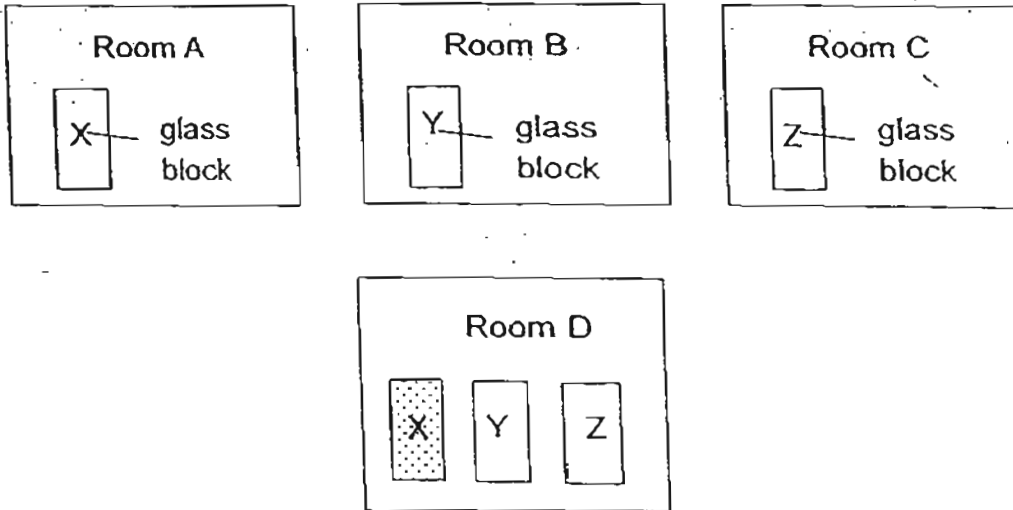

- (a) What can you conclude about the temperature of the rooms? [2]

---

---

- (b) Explain Aaron's observations of blocks X, Y and Z in Room D. [2]

---

---

43. Colin wanted to find out how the height of the water wheel placed from the running water will affect the speed of the water wheel.

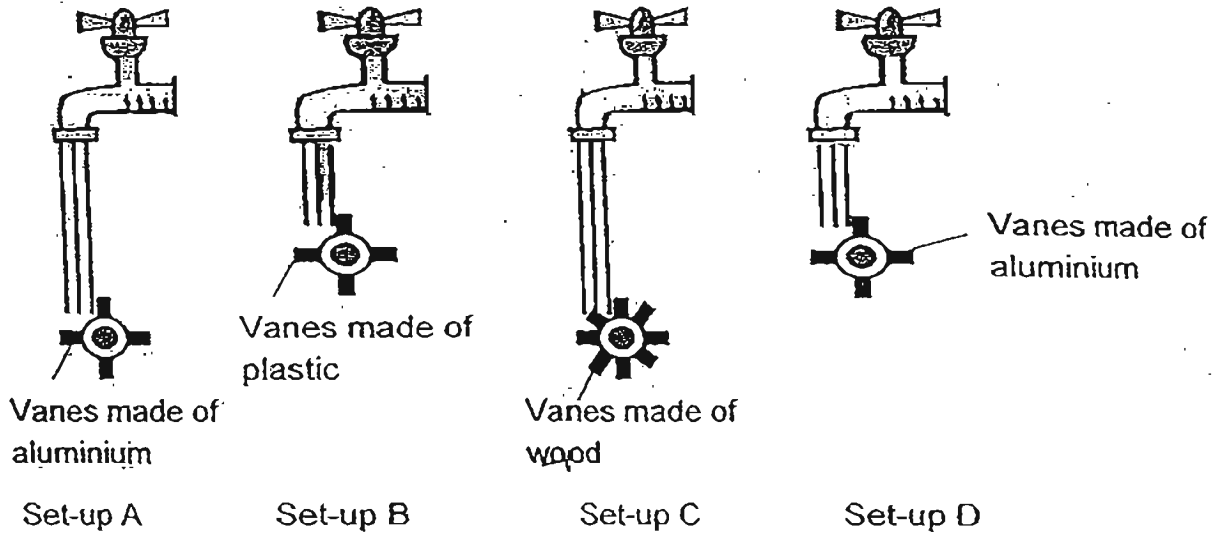

- (a) Colin used set-ups B and C to conduct the experiment. Explain if you agree with him. [2]

---

---

- (b) When Colin decided to use set-ups A and D, Gina predicted that the water wheel would spin slower when it was brought lower under the tap. Colin disagreed and said it would spin faster. Who is correct? Explain your answer. [2]

---

---



44. Shanna set up an experiment as shown below.

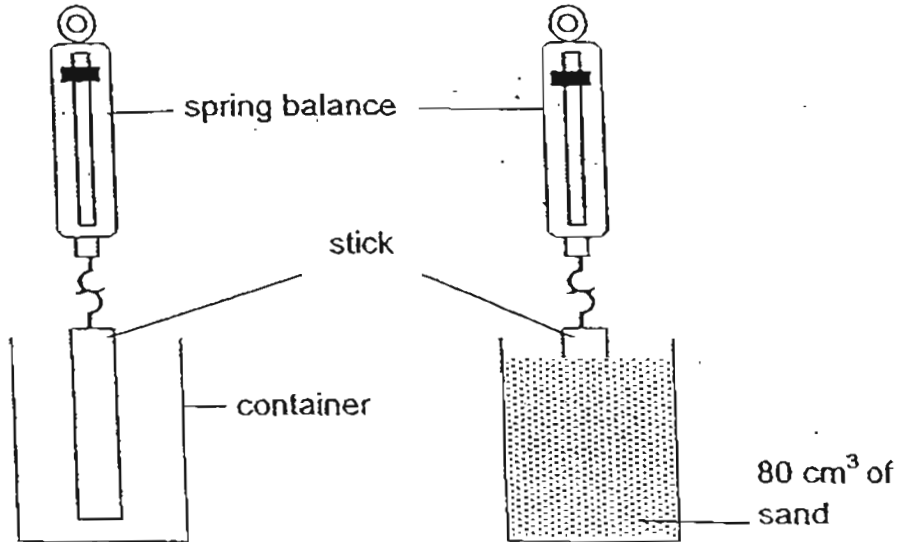

First, she measured the force she needed to lift the stick upwards. Then, she poured in  $80 \text{ cm}^3$  of sand and pulled the stick slowly upwards. She recorded the amount of force needed to pull the stick out.

(a) What was the force that caused the spring to stretch in set-up A? [1]

(b) Explain why there was an increase in the force needed to pull the stick out each time she increases the amount of sand that is poured in. [2]

-End of Paper-







# ANSWER SHEET

**EXAM PAPER 2011**

**SCHOOL : CATHOLIC HIGH  
SUBJECT : PRIMARY 6 SCIENCE**

**TERM : PRELIMINARY 1**

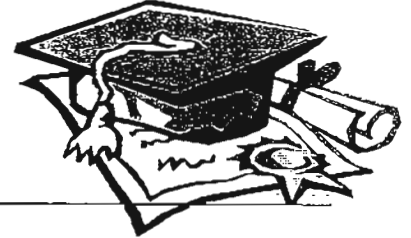

Q1	Q2	Q3	Q4	Q5	Q6	Q7	Q8	Q9	Q10	Q11	Q12	Q13	Q14	Q15	Q16	Q17
2	3	3	3	4	4	2	4	4	2	2	4	2	2	1	1	3

Q18	Q19	Q20	Q21	Q22	Q23	Q24	Q25	Q26	Q27	Q28	Q29	Q30
1	1	2	2	3	4	1	2	3	2	4	3	3

31)a)As the breathing rate increases, the heart beat rate also increases.

b)

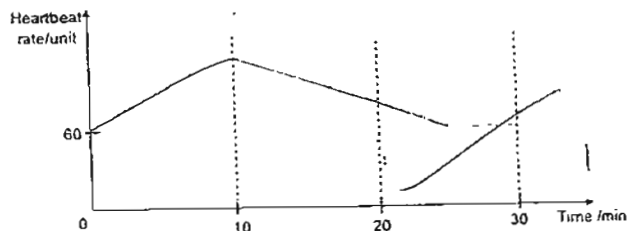

32)a)In the human circulatory system, air is circulated from the lungs to the heart which pumps the blood rich in oxygen to other parts of the body, but in the fish circulatory system, air is circulated from the gills to other parts of the body without passing through the heart.

b)The blood found at location X and Y are poor in oxygen and rich in carbon dioxide.

33)a)Part X and Y controls the cell.

b)During fertilization, Part Y of the female egg cell fuses with Part X of the male cell.

34)a)The stronger the wind, the greater is the number of fruits dispersed by Plant X. The number of fruits dispersed by plant Y is not affected by the strength of the wind.

b)The fruits of Plant X has parachute-like structure and it is also light.

35)a)

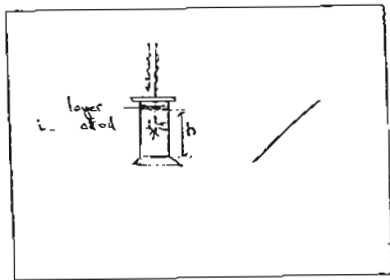

b)The height of the remaining water.

36)a)Leaf A has a greater mass than Leaf B.

b)There are more stomata on the underside than the upper surface of a leaf. Since Leaf B has oil on the upper surface, it will lose more water than leaf A which has oil on the underside. Thus leaf A has greater mass than leaf B.

37)a)Solution X could be iodine.

b)Bag A is semi-permeable while bag B is not.

c)Since Bag A is semi-permeable, it allows solution X to enter. Iodine turns dark blue in the presence of starch. Bag B does not allow solution X to enter so the solution in Bag B remains white.

38)a)The paper clips will be attracted to the steel rods.

b)Put the same pole of a magnet near each pole of steel rods, X and Y. If one pole is attracted while the other pole repels with the magnet, this will confirm they have become temporary magnets because only magnets can repel.

39)a)As the number of weights added increases, the volume of Matter X decreases.

b)She can conclude that Matter X is a gas and can be compressed.

40)a)

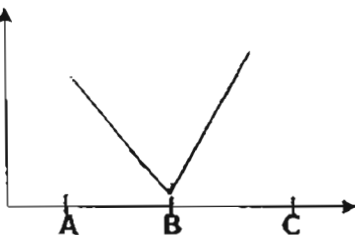

b)As Judy walked from A to B, her distance from the lamp post decreases, so the length of the shadow also decreases. At B, the lamp post is directly overhead so her shadow is the shortest. As she walked from B to C, her distance from the lamp post increases, so the length of her shadow also increases.

41)a)Circuit A should be used. If one wire in circuit A breaks, the heating element will continue to work and only one wire will not heat the window, but if one part in circuit B is broken, the whole circuit will stop working.

b)Circuit A is heated up in parallel but circuit B is heated up in parallel. One disadvantage is circuit A takes a longer time to heat up than circuit B.



42)a)The temperature of Room A which glass block X was put in was lower than the temperature of Room D while the temperature of Room B and C which glass box Y and Z was put in was higher than the temperature of Room D.

b)The water vapour in the surrounding air in Room D condensed on the surface of glass block X, forming water droplets while the temperature glass Y and Z were higher than the surrounding air so there was no water droplets on them.

43)a)I do not agree with him. It is not a fair test. The vanes are not made of the same material. The water wheels have different number of vanes.

b)Colin is correct. As the height of the water wheel placed from the running water increases, the potential energy of the running water also increases which is changed to greater kinetic energy making the wheel spin faster.

44)a)The weight of the stick.

b)As the weight of sand that is poured in increases, the frictional force between the sand and the stick also increases. Extra is needed to overcome this frictional force.