

Index No.

--	--	--	--	--	--	--	--	--	--

ANGLO-CHINESE SCHOOL (JUNIOR)
ANGLO-CHINESE SCHOOL (PRIMARY)



COMBINED PRELIMINARY EXAMINATION 2006
SCIENCE
BOOKLET A

NAME : _____ () CLASS : P6. _____

DATE : 29th August 2006

Total Time For Booklets A and B : 1 hour 45 minutes

INSTRUCTIONS TO PUPILS

DO NOT TURN OVER THE PAGES UNTIL YOU ARE TOLD TO DO SO

Follow all instructions carefully.

There are 30 questions in this booklet.

Answer ALL questions.

INFORMATION FOR PUPILS

The total marks for this booklet is 60.

The total time for Booklets A and B is 1 hour 45 minutes.

This question paper consists of 21 printed pages. (Inclusive of cover page)

PART I

For each question from 1 to 30, four options are given. One of them is the correct answer. Make your choice (1, 2, 3 or 4). Shade the correct oval (1, 2, 3 or 4) on the Optical Answer Sheet. (30 x 2 marks)

1 Which of the following is/are possible sources of light energy for us to see at night?

- Sun
- Moon
- Lighted candle

- B only
- A and C only
- B and C only
- All of the above

2 Study the classification chart of 4 different materials (A, B, C and D) below.

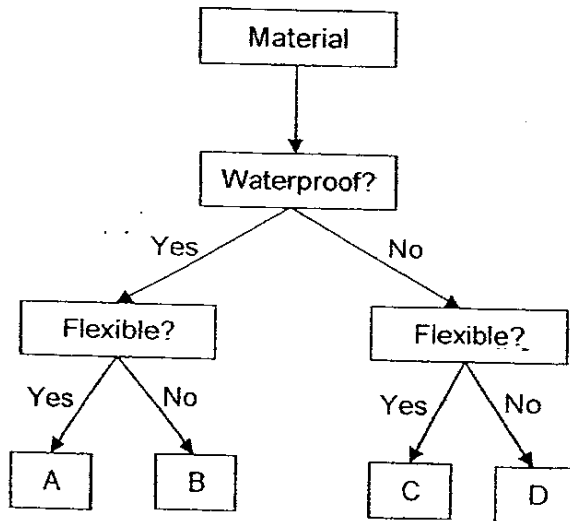

Which material is most suitable for making a towel?

- (1) A
- (2) B
- (3) C
- (4) D

(Go on to the next page)

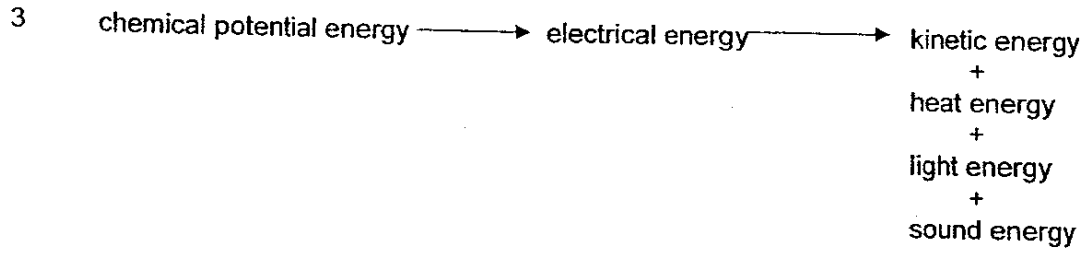

The energy conversion shown above is most likely to be found in a _____.

- dynamo
- calculator
- handphone
- microscope

4 Lucas looks through a bamboo pole as shown below.

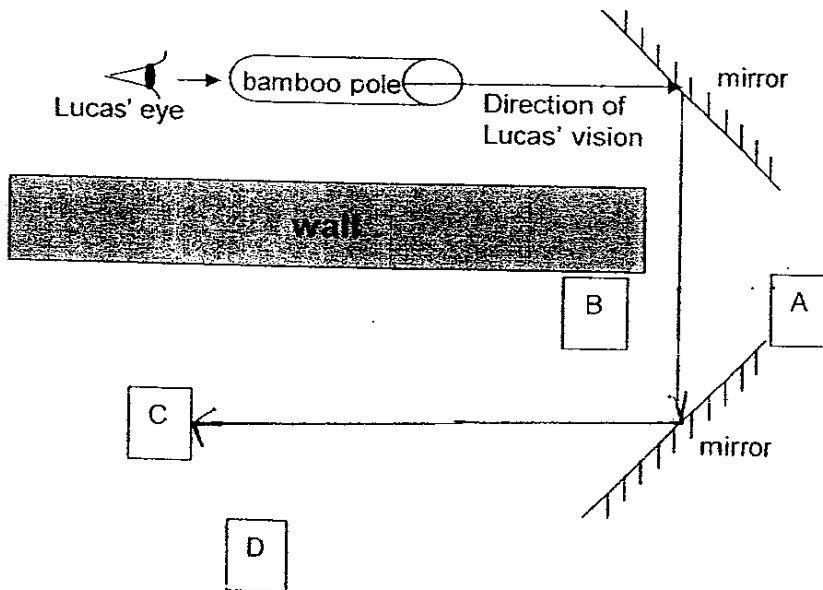

From the diagram above, which box(es) will Lucas see?

- A only
- C only
- A and B only
- B, C and D only

(Go on to the next page)

5 4 different loads (A, B, C and D) are being balanced using lever systems as shown below.

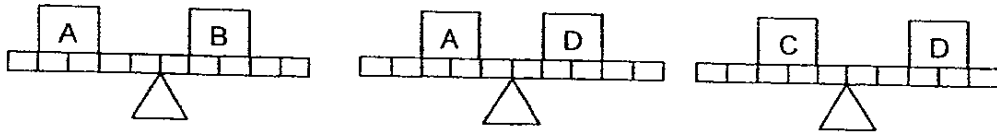

Which of the following shows the correct positions of load B and C when they are in balance?

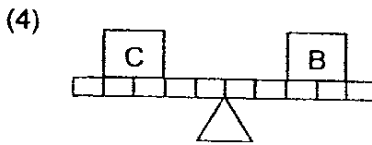
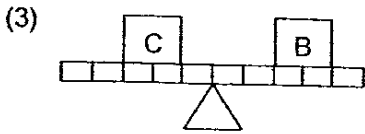
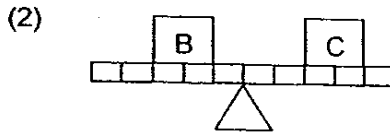
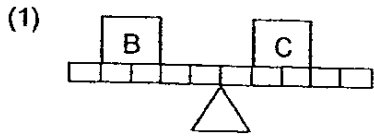

6 When 4 metallic objects were suspended in the air, the following observation was made.

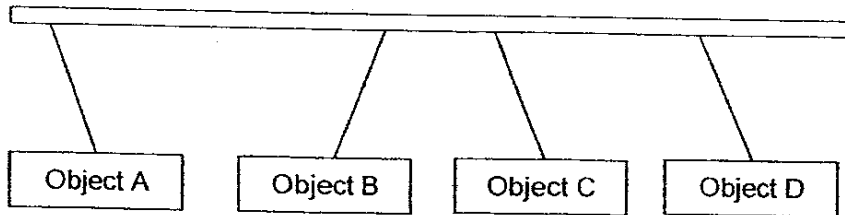

Which of the following best describes the objects?

	Object A	Object B	Object C	Object D
(X)	Magnetic Material	Magnet	Magnetic Material	Magnetic Material
(X)	Magnet	Magnetic Material	Magnet	Magnet
(X)	Magnetic Material	Magnet	Magnet	Magnet
(X)	Magnet	Magnetic Material	Magnetic Material	Magnetic Material

(Go on to the next page)

- 7 Joe arranged a few domino blocks as shown below. He then pushed the first block and the rest of the blocks toppled over.

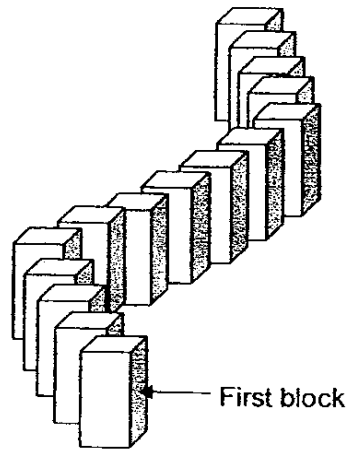

This demonstrates that a force can _____.

- make a stationary object move
- change the shape of an object
- stop a moving object

- C only
- A and B only
- A and C only
- A, B and C

- 8 The table below shows the amount of carbon dioxide in the atmosphere in 3 different years.

Year	1940	1990	2000
Carbon dioxide (parts per million)	300	330	370

Which one of the following activities contributed most to this change?

- Destruction of rain forests
- Use of non-biodegradable materials
- Dumping untreated sewage into rivers
- Increase in the amount of household refuse

(Go on to the next page)

9 Which one of the following animals will be least affected if the amount of dissolved oxygen in the pond decreases?

(1)

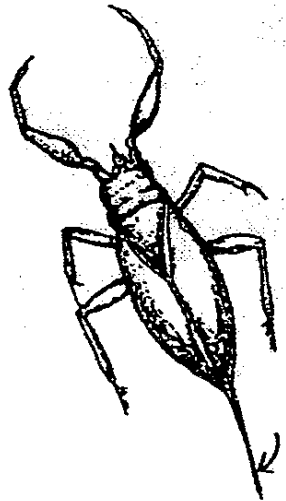

(2)



(3)

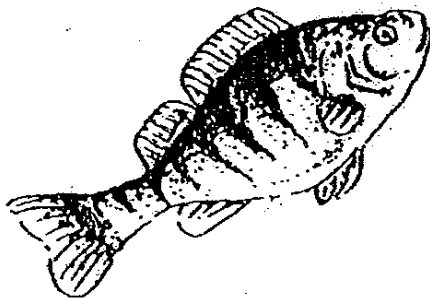

(4)



10 Which of the following can conduct heat?

- A wind
- B ice water
- C aluminium

- (1) C only
- (2) A and B only
- (3) B and C only
- (4) A, B and C

(Go on to the next page)

11 Study the map below.

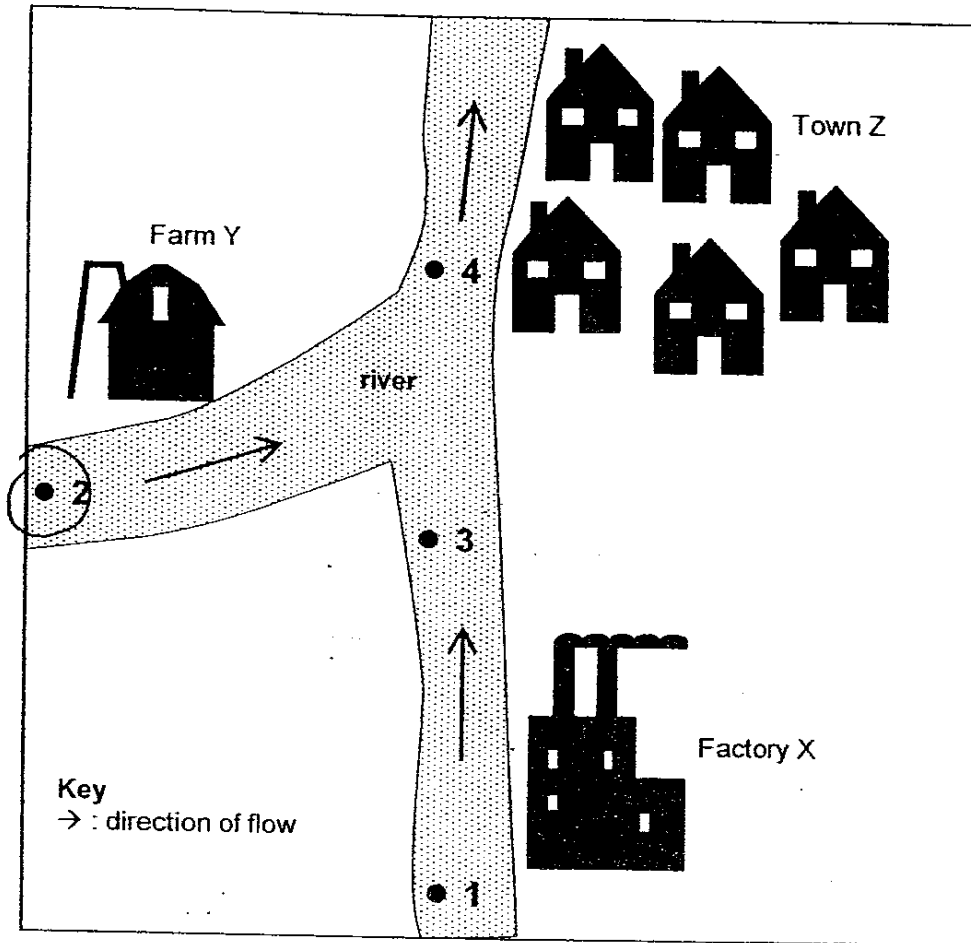

An environmentalist wanted to find out how much of the pollution in the river was due directly to Factory X. At which 2 places should he collect samples of water from?

- 1 and 3
- 1 and 4
- 2 and 3
- 2 and 4

12 Kim has a potted plant. She wants to obtain a leaf that does not contain starch. Which of the following is the best way of obtaining such a leaf?

- (1) Do not put fertilizer in the soil.
- (2) Do not water the plant for a day.
- (3) Put the plant under a bright light in her room.
- (4) Keep the plant in a wooden cupboard for a few days.

(Go on to the next page)

13 Study the chart below.

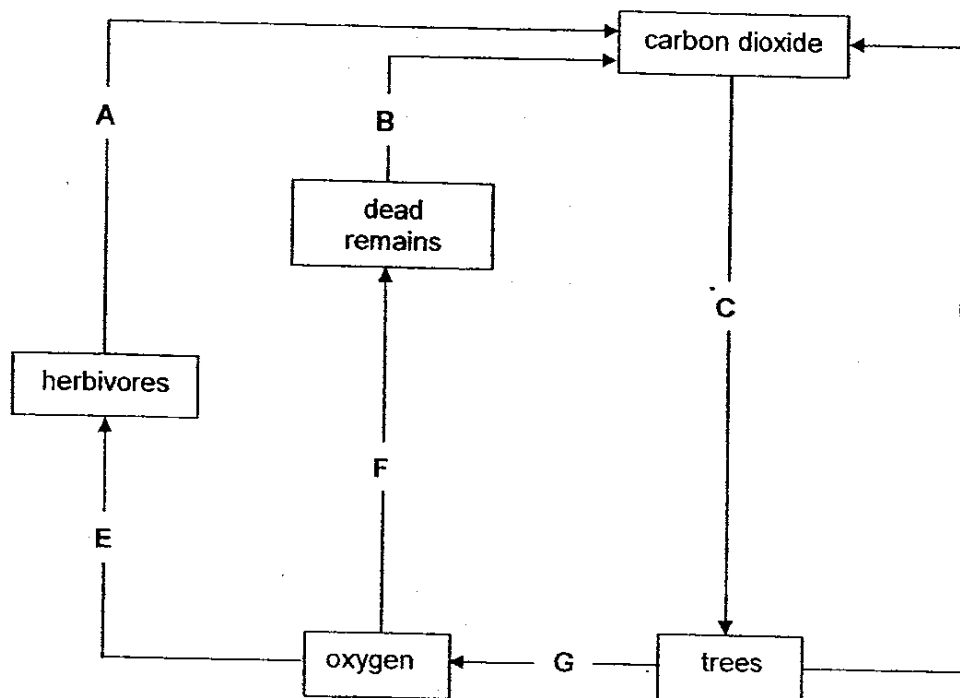

Which one of the following correctly identifies the processes of respiration and photosynthesis?

	Respiration	Photosynthesis
(1)	A	E
(2)	B	C
(3)	E	G
(4)	F	D

(Go on to the next page)

- 14 Lichens are organisms which are very sensitive to air pollution. The graph below shows how the distance from a power station affects the number of different types of lichen growing.

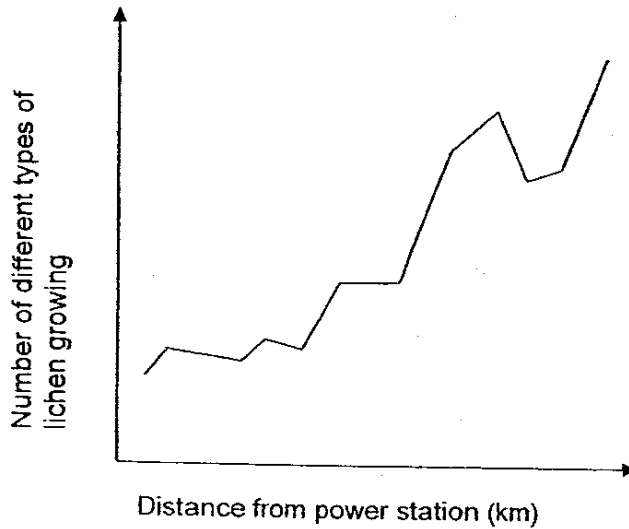

Which one of the following conclusions can be drawn from the graph above?

- (1) Less lichens grow further away from the power station.
 - (2) There are fewer types of lichen growing near the power station.
 - (3) As the distance from the power station increases, air pollution increases.
 - (4) The number of types of lichen growing decreases as the distance from the power station increases.
- 15 When an ice-skater is skating on ice, which force(s) is/are acting on her skating shoes?

A frictional
 B gravitational
 C elastic

A B only
 B A and B only
 C B and C only
 D A and C only

(Go on to the next page)

16 The diagram below shows the animals and plants in a pond.

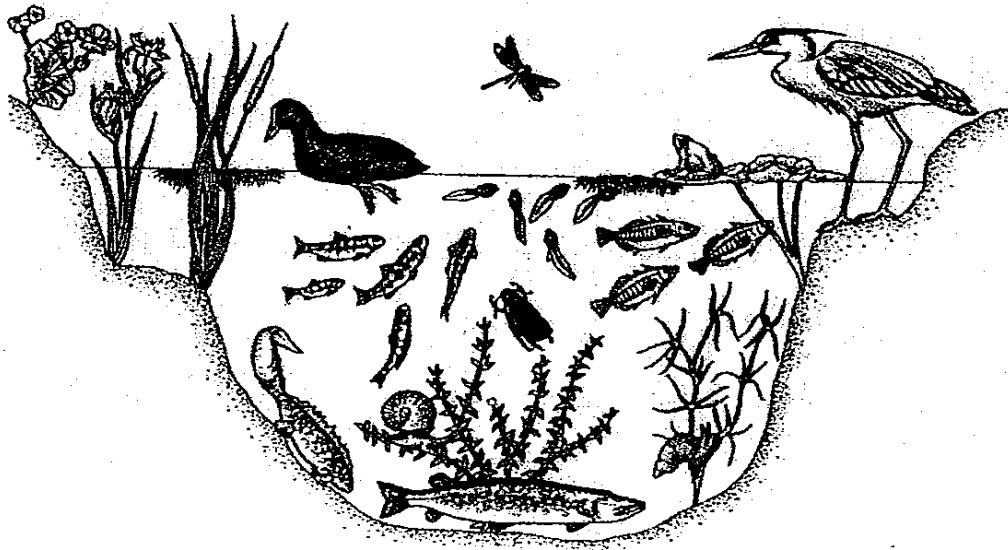

Based on the diagram, which of the following statements is/are correct?

- A The birds form a population.
- B The hydrillas form a population.
- C The living things in the pond form a community.
- D The living and non-living things in the pond form a community.

- A only
- B and C only
- A and D only
- A, B and D only

(Go on to the next page)

17 The diagram shows a branching key which can be used to classify living things.

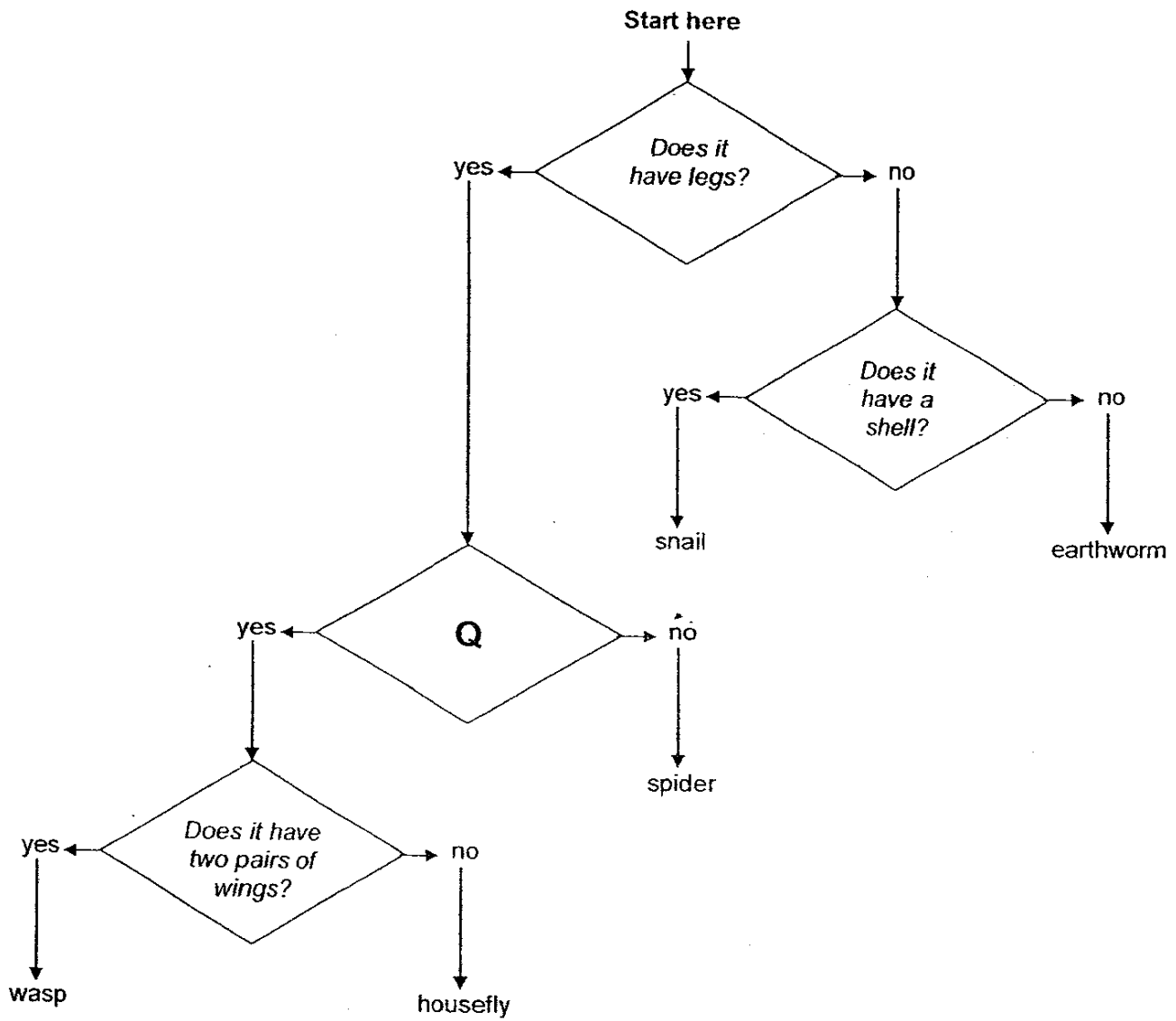

Which one of the following questions should be placed in Q?

- Does it have six legs?
- Does it have a skeleton?
- Does it have two body parts?
- Does it have hair on its body?

(Go on to the next page)

18

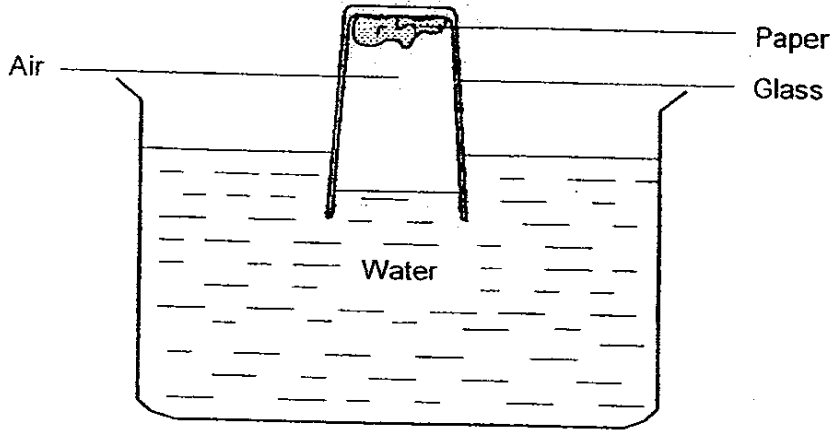

The above experiment was set up in which a piece of paper was pasted onto the inner bottom surface of a glass. When the glass was forced upside down into the basin of water, the paper remained dry. Which property of air did this demonstrate?

- (1) Air has mass.
- (2) Air occupies space.
- (3) Air cannot dissolve in water.
- (4) Air takes the volume of the container in which it is kept.

19 Leonard did a study on 3 animals, S, T and U. He drew a checklist and placed a tick (✓) in the box when he made the observation. At the end of his study, the completed checklist is as follows:

Observation	Animal S	Animal T	Animal U
Young resembles the adult.	✓	✓	✓
Gives birth to young alive.			✓
3 stages in the life cycle.	✓	✓	
Moults several times at one stage in its life cycle.		✓	

Which of the following could be Animals S, T and U?

Animal S	Animal T	Animal U
chicken	frog	horse
horse	cockroach	crocodile
chicken	cockroach	horse
cockroach	frog	horse

- 20 Fu Ming wanted to find out if the size of the exposed surface area affected the rate of evaporation. He prepared the set-ups using bowls of the same material. Which two set-ups should he use?

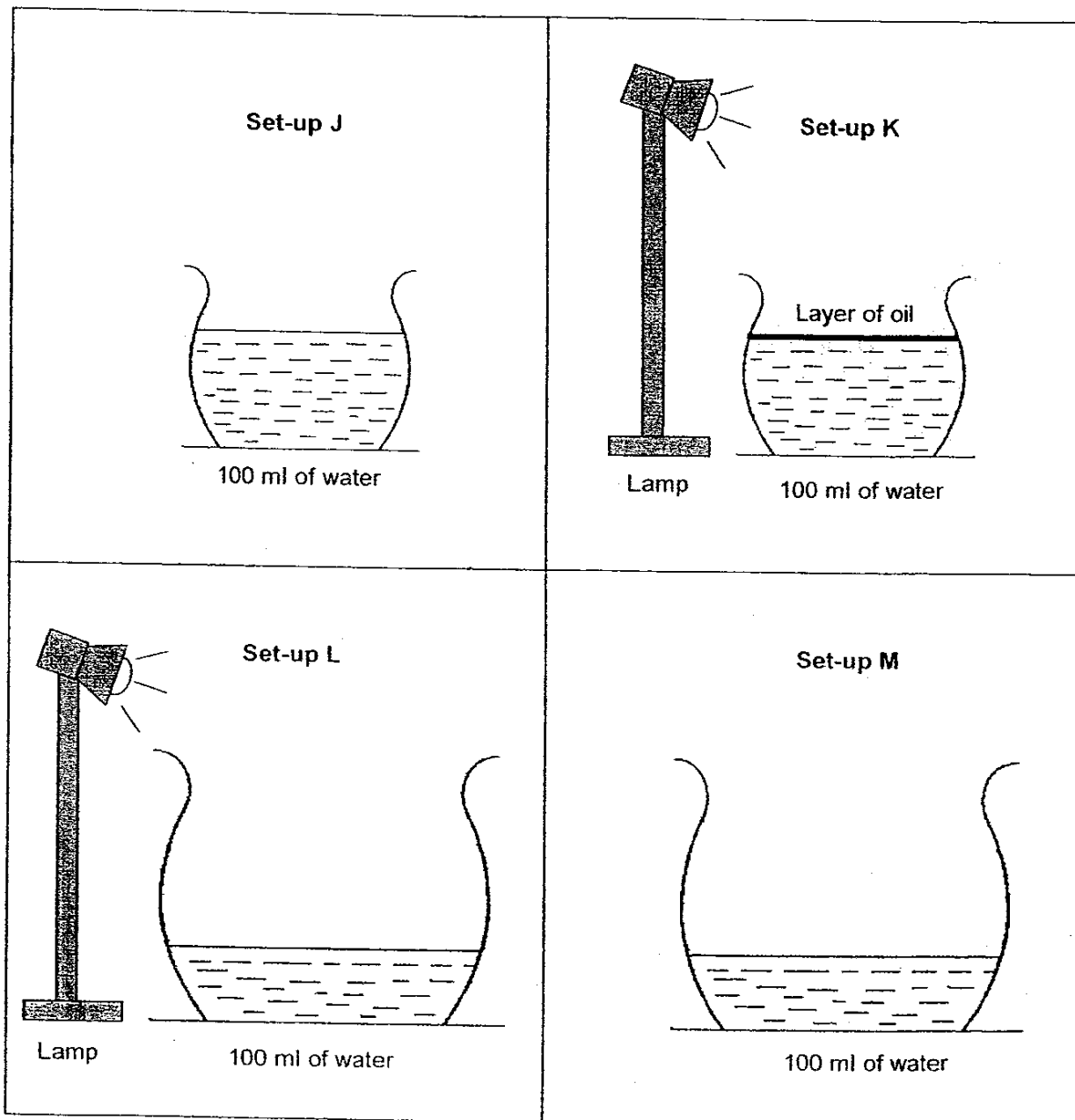

- (1) J and K
- (2) J and M
- (3) K and L
- (4) L and M

(Go on to the next page)

21 The chart below shows how some plants reproduce.

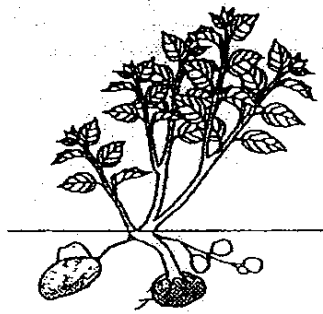
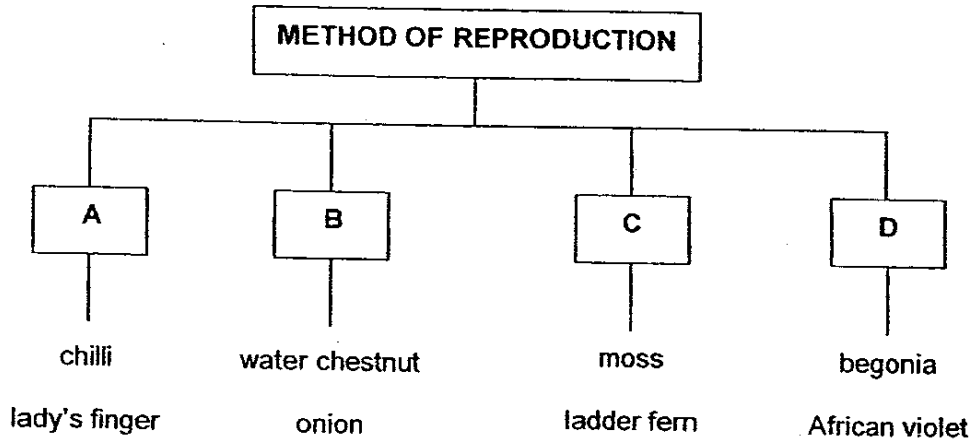

potato plant

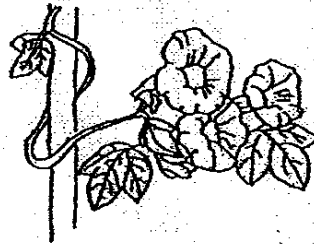

morning glory plant

In the classification chart above, which groups do the potato plant and the morning glory plant belong to?

- | | potato plant | morning glory plant |
|-----|---------------------------------------|---------------------|
| (1) | <input checked="" type="checkbox"/> B | A |
| (2) | <input type="checkbox"/> A | B |
| (3) | <input type="checkbox"/> C | D |
| (4) | <input type="checkbox"/> D | C |

(Go on to the next page)

- 22 The graph below shows the distances of the orbital paths of 3 planets, Q, R and S around the Sun in our Solar System.

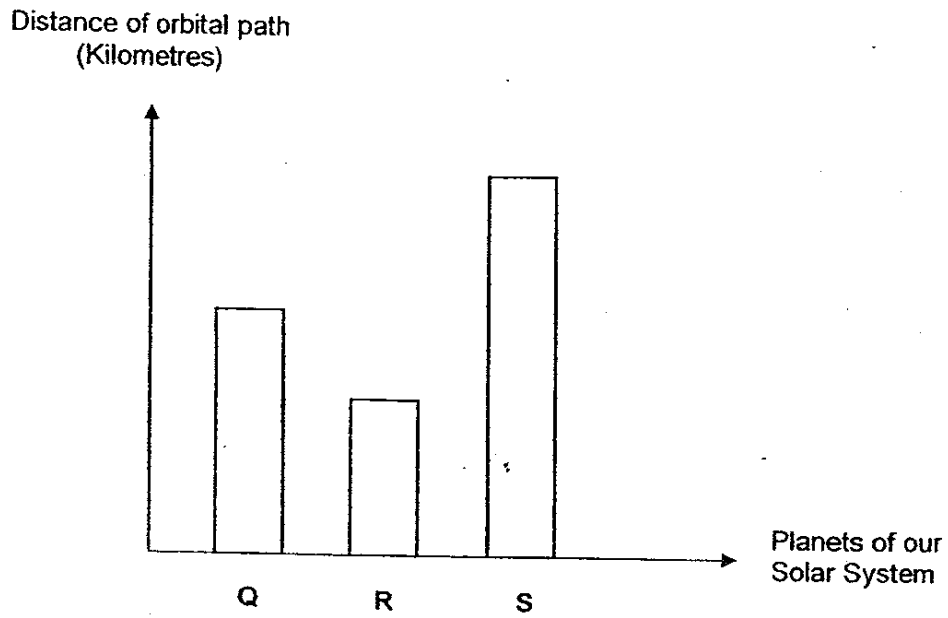

Which of the following statement(s) is/are true?

- Planet R is colder than Planet S.
- Planet S takes the shortest time to make an orbit around the Sun.
- Planet Q takes a longer time to make one revolution than Planet R.

- A only
- C only
- A and B only
- B and C only

(Go on to the next page)

23

The diagram shows 4 different kinds of cells.

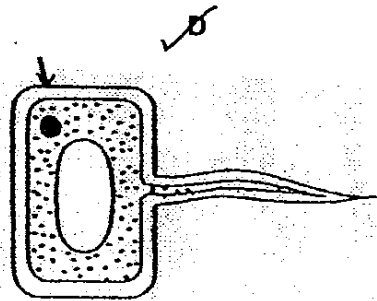
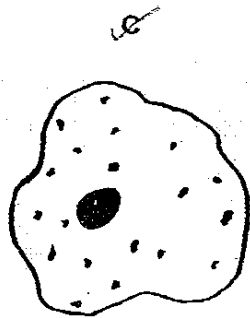
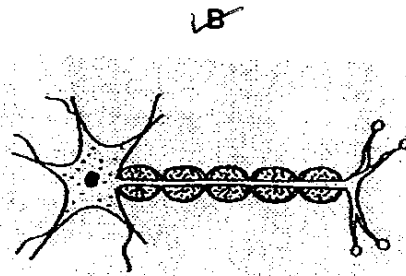
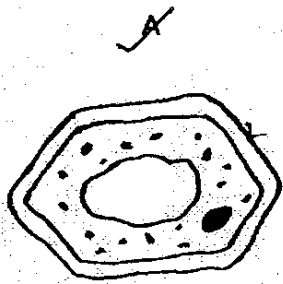

Which of them are plant cells?

- (1) A and C only
- (2) A and D only
- (3) B and D only
- (4) B, C and D only

(Go on to the next page)

- 24 Sammy observed some leaves and grouped them according to their characteristics.

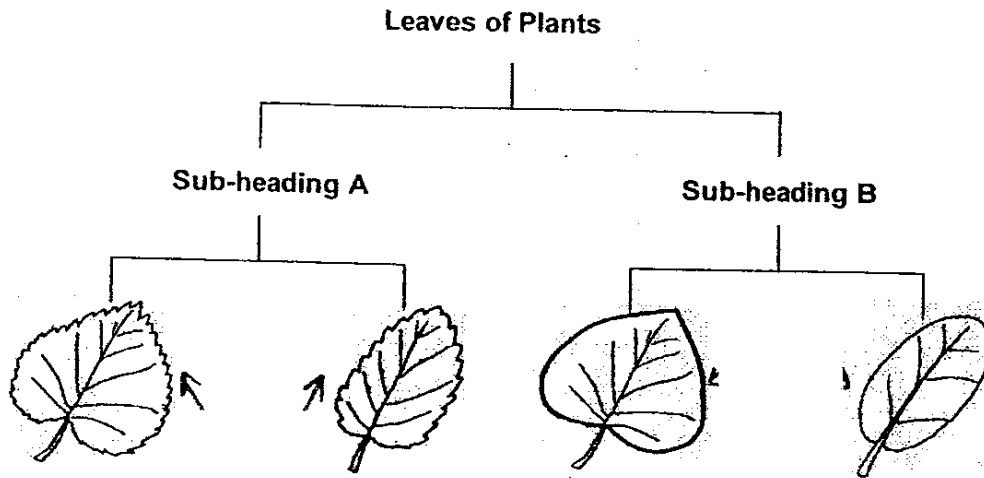

Which of the following could be Sub-heading A?

- (1) Entire edge
 - (2) Jagged edge
 - (3) Oval shaped
 - (4) Heart shaped
- 25 Diagram A shows a cross-section of a stem and diagram B shows part of the human circulatory system.

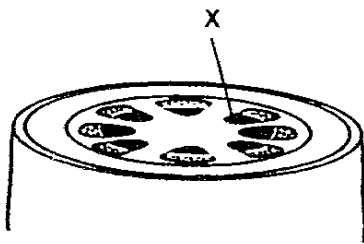

Diagram A

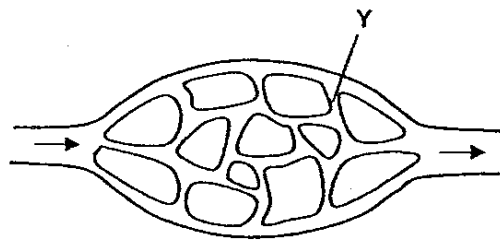

Diagram B

Which one of the following is a function of **both** part X and part Y?

- (1) Transports water
- (2) Transports blood
- (3) Keeps the organism upright
- (4) Keeps the surrounding cells at a constant temperature

(Go on to the next page)

26 The diagram shows the human skeletal system.

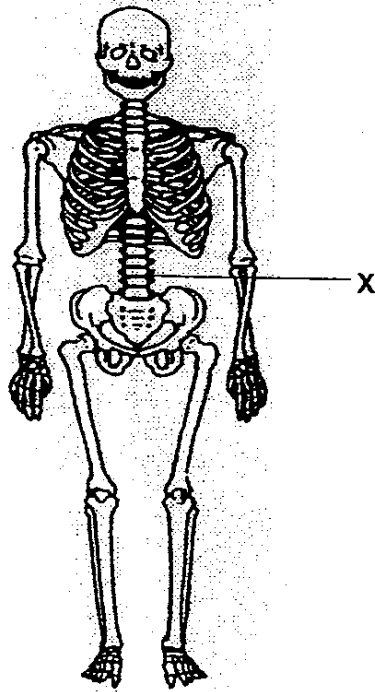

Which of the following describes the function(s) of X?

- A To protect the brain
- B To support the rib cage
- C To protect the spinal cord
- D To allow the body to move

- (A) C only
- (B) A and B only
- (C) A, B and D only
- (D) B, C and D only

(Go on to the next page)

27 The clips of a circuit card are tested with a circuit tester. The results are given in the table below.

Clips tested	Bulb of circuit tester
A and B	Does not light up
C and E	Does not light up
A and F	Lights up
B and D	Does not light up
C and F	Lights up

Which of the following shows the correct circuit card tested?

<p>(1)</p>	<p>(2)</p>
<p>(3)</p>	<p>(4)</p>

(Go on to the next page)

28 Ali and his friends prepared 3 set-ups and placed them in an open field from 7am to 7pm. They monitored the concentration of oxygen in the set-ups every hour.

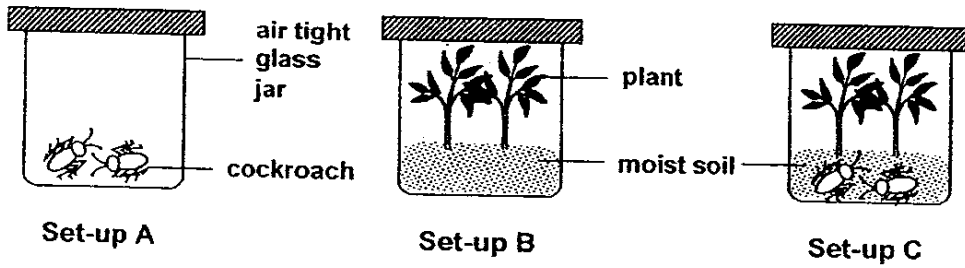

At the end of the investigation, his friends made the following conclusions.

- Sulin : There was an equal amount of oxygen at 1pm in all the set-ups.
- Ram : Set-up C had the most amount of oxygen at the end of the experiment.
- Omar : There was more oxygen in Set-up B than C at the end of the experiment.

Which of Ali's friends was/were correct?

- (1) Sulin only
- (2) Omar only
- (3) Omar and Ram only
- (4) Ram and Sulin only

29 The diagram shows a set-up to investigate the changes that occur when mealworms respire.

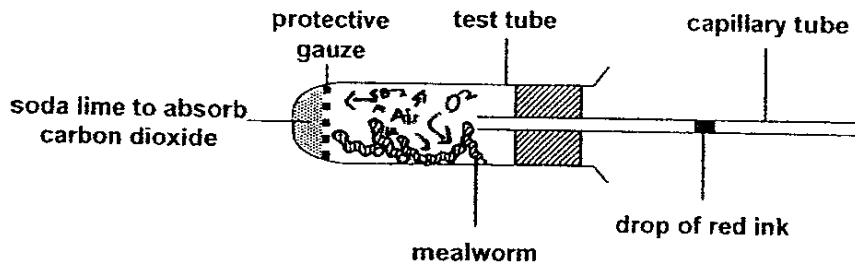

What will happen to the drop of red ink in the capillary tube and why?

Red Ink	Reason
(1) remains where it was	volume of air in test tube does not change
(2) moves towards the test tube	carbon dioxide was taken in by the mealworms
(3) moves towards the test tube	oxygen was taken in by the mealworms
(4) moves away from the test tube	oxygen was given out by the mealworms

(Go on to the next page)

30. An artificial plant and a live plant were each placed into identical containers filled with 200ml of water. A layer of oil was poured into each container to prevent the water from evaporating.

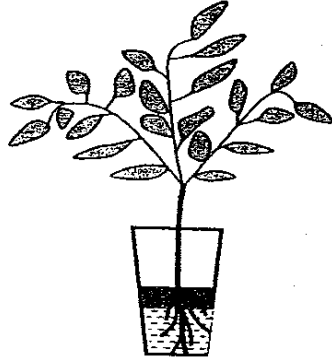

Container A

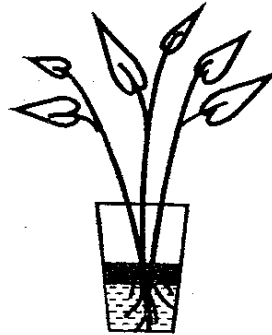

Container B

The volume of water in each container was measured on the 1st and 7th day. Which of the following sets of measurements is most likely to be correct?

Volume of water (ml) on Day 7		
	Container A	Container B
(1)	185	175
(2)	175	200
(3)	175	185
(4)	200	200

Index No.

--	--	--	--	--	--	--	--

ANGLO-CHINESE SCHOOL (JUNIOR)
ANGLO-CHINESE SCHOOL (PRIMARY)



COMBINED PRELIMINARY EXAMINATION 2006
SCIENCE
BOOKLET B

NAME : _____ () CLASS : P6. _____

DATE : 29th August 2006

Total Time For Booklets A and B : 1 hour 45 minutes

INSTRUCTIONS TO PUPILS

DO NOT TURN OVER THE PAGES UNTIL YOU ARE TOLD TO DO SO

Follow all instructions carefully.

There are 16 questions in this booklet.

Answer ALL questions.

INFORMATION FOR PUPILS

The number of marks is given in brackets [] at the end of each question or part question.

The total marks for this booklet is 40.

The total time for Booklets A and B is 1 hour 45 minutes.

This question paper consists of 16 printed pages. (Inclusive of cover page)

Question Number	Possible Marks	Marks Obtained
31	2	
32 – 33	4	
34	3	
35 – 36	5	
37	3	
38	3	
39	3	
40	3	
41	2	
42	2	
43	2	
44	2	
45	3	
46	3	

Bklet A	/60
Bklet B	/40
Total	/100
Parent's Signature / Date	

PART II

For questions 31 to 46, write your answers in this booklet.

The number of marks available is shown in brackets [] at the end of each question or part question. (40 marks)

- 31 The graph below shows the relationship between the load of different masses hung on an 8-cm long spring and its extension.

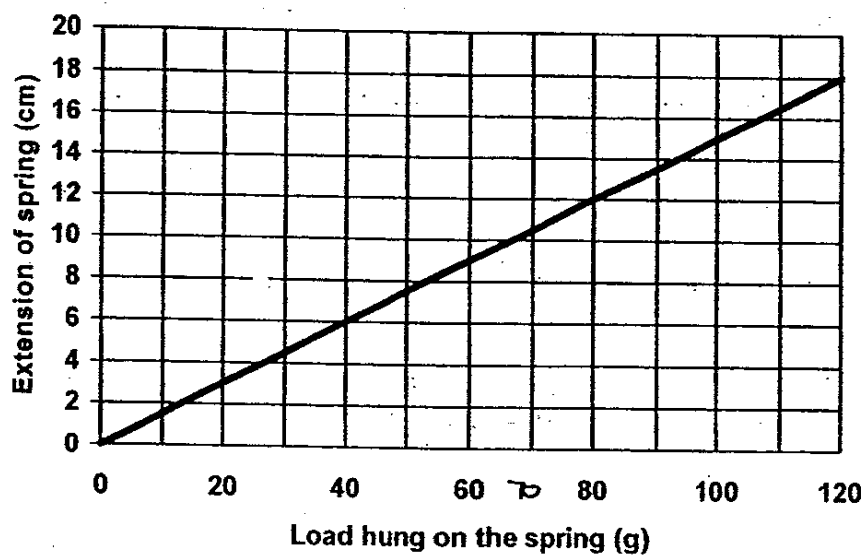

- (a) What is the length of the spring when a 70g load is hung on it? [1]

- (b) State the relationship between the amount of load hung on the spring and the extension of the spring. [1]

(Go on to the next page)

SCORE	2
-------	---

32

Gopal conducted an investigation on 3 types of simple machines and recorded the following results.

Simple Machine	Load (g)	Effort (g)	Distance travelled by the load (cm)	Distance travelled by the effort (cm)
A	50	70	15	8
B	60	40	9	12
C	80	30	14	7

- (a) Which simple machine (A, B or C) uses the same principle as a door knob? Explain your answer. [1]

- (b) Gopal's teacher said that Gopal might have made a mistake when he was recording the result for one of the simple machines. Identify that simple machine and explain your answer. [1]

33

A damselfly nymph uses its gills to breathe. Wilson wants to find out the rate at which the gills of a damselfly beat in 3 different samples of water, A, B and C. He recorded his results in the table below.

Water Sample	Gill beats per minute
A	70
B	200
C	140

- (a) Which water sample contains the most amount of oxygen? Give a reason for your choice. [1]

- (b) What are the two sources of oxygen in the pond? [1]

34 Sufri shone a torch at an object from 3 different directions A, B and C as shown below.

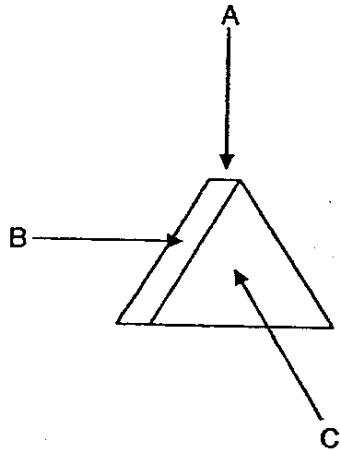

(a) Draw the shadows Sufri saw from direction A and B in the table below. The shadow Sufri saw from direction C is drawn for you. [2]

Direction the torch was shining from	Shadow Sufri saw
A	
B	
C	

(b) What is the important property of the object above that enables the shadow to be formed? [1]

(Go on to the next page)

Bacteria are used to make yoghurt from milk. The flow chart below shows the steps a housewife took to prepare yoghurt in her kitchen.

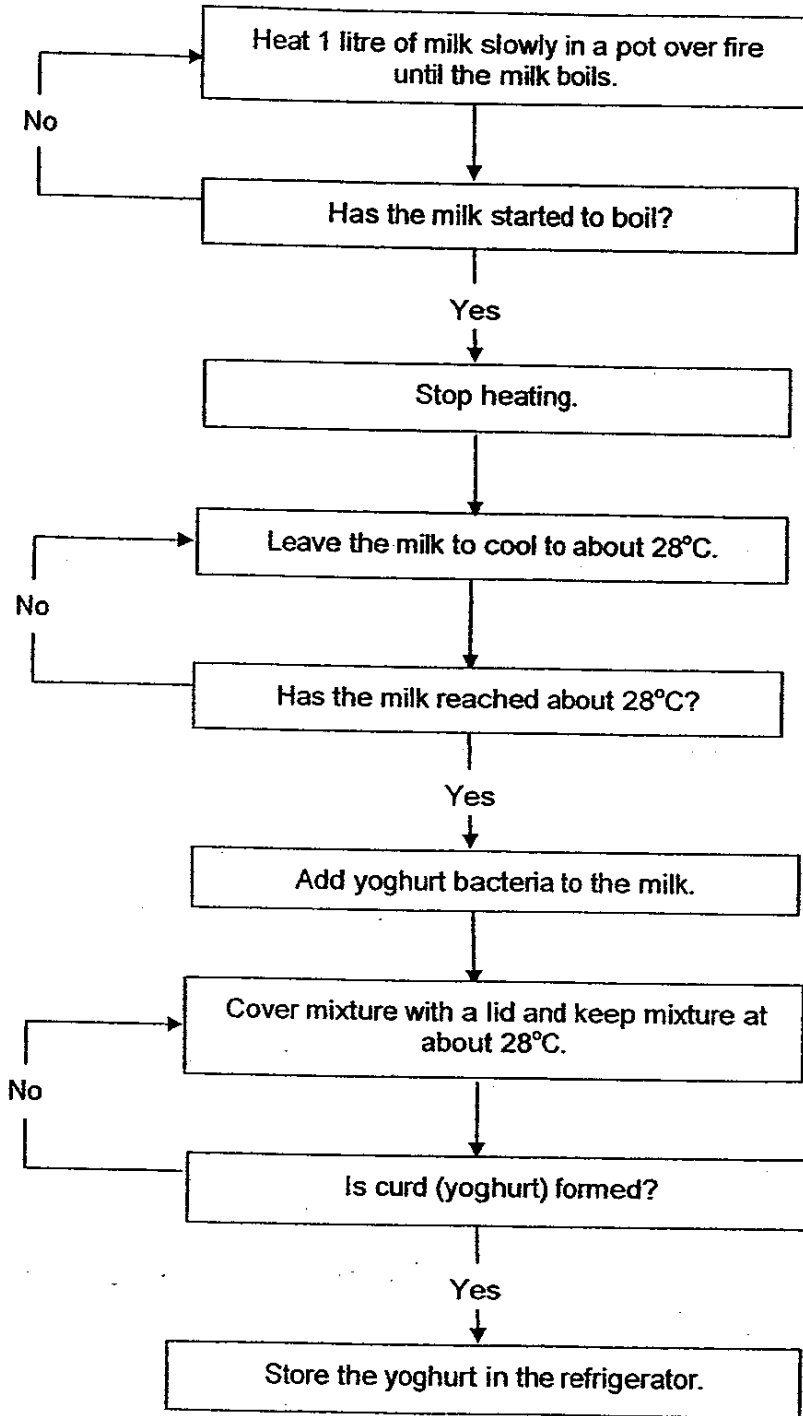

(Go on to the next page)

Use the flowchart to answer the following questions.

- (a) Why must the milk be heated at the beginning? [1]

- (b) When are the yoghurt bacteria added to the milk? [1]

- (c) What is a suitable temperature for the yoghurt bacteria to multiply? [1]

- 36 The graph below shows how much sugar is produced by a plant over a period of 4 days when it is placed on a window sill.

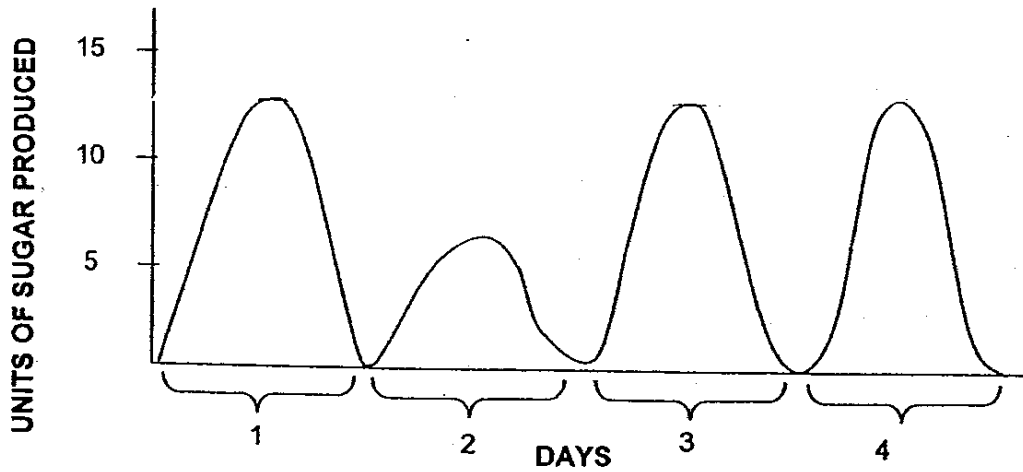

- (a) Less sugar was produced in Day 2. Describe a change in the environment that could have caused it. [1]

- (b) Draw a line on the same graph above to show how much sugar would be produced if the plant was kept under very bright light throughout the 4 days. [1]

(Go on to the next page)

SCORE	5
-------	---

37 Mark set up the investigation below to compare the heat conductivity of 4 different materials (A, B, C and D).

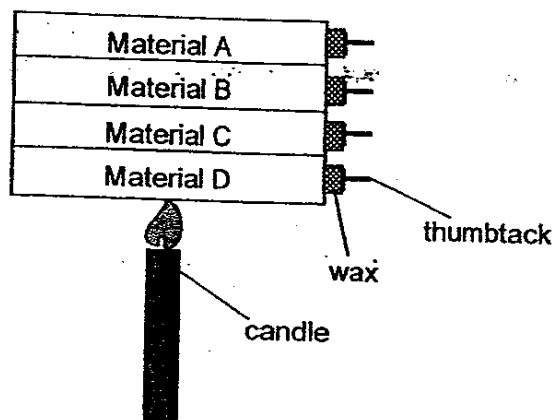

He recorded the results below.

Material	Time taken for the thumbtack to drop (min)
A	8
B	6
C	2
D	4

(a) Is Mark's investigation a fair one? Explain your answer.

[2]

(b) For the conclusions below, state 'True', 'False' or 'Not Possible To Tell' in the boxes beside each conclusion.

[1]

(i)	Material A is a better conductor of heat than Material B.	
(ii)	Material C is a better conductor of heat than Material D.	

(Go on to the next page)

SCORE	3
-------	---

38

George wants to compare two different soil samples, A and B, to find out which is able to retain more water. He made use of the following materials.

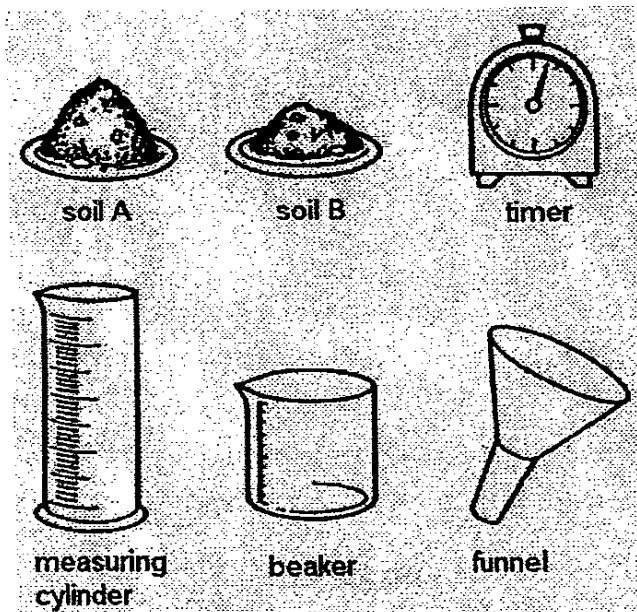

(a) Explain how he would use each of the following. [2]

(i) Measuring cylinder: _____

(ii) The timer : _____

(b) Why is the presence of dead plants and animals in the soil important to plants? [1]

(Go on to the next page)

SCORE	3
-------	---

The diagram shows the different stages in the life cycle of a flowering plant.

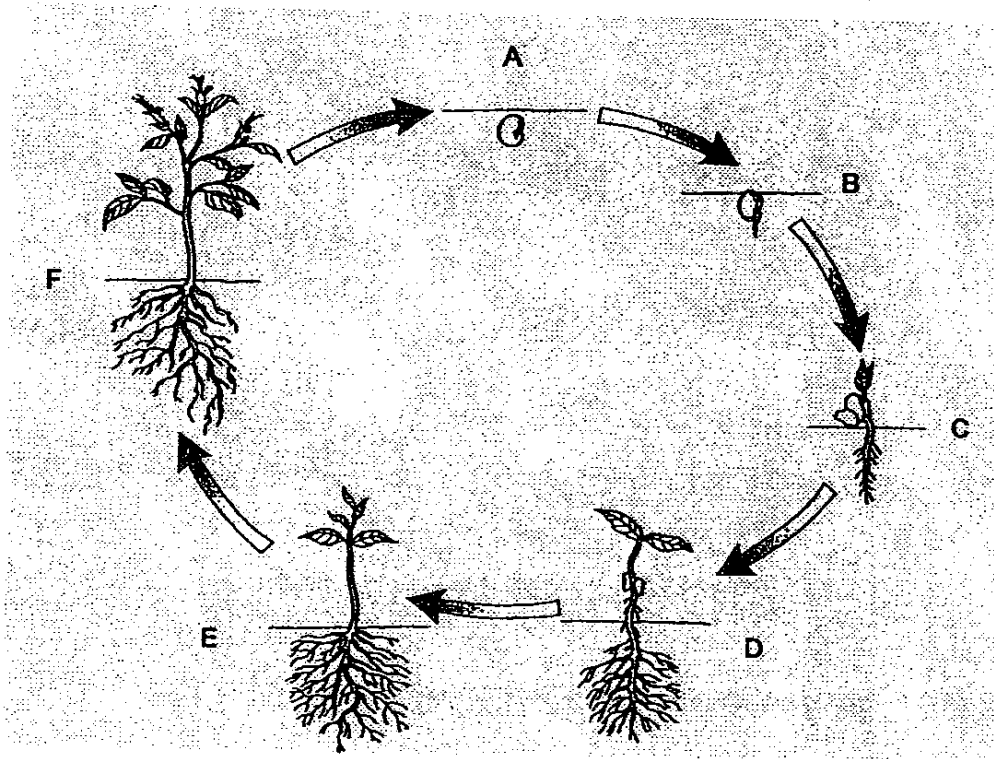

(a) What two processes must occur at stage F for the plant to progress to Stage A? [1]

(b) What happens to the seed leaves at Stage C as the seedling grows taller? [1]

(c) Very often, a seedling struggles to grow as it competes for resources. What must a mature adult plant do to increase its chances of having many healthy seedlings? [1]

(Go on to the next page)

SCORE	/
	3

40

Allan fixed an inflated balloon over a glass tube and placed his thumb over the opening of the glass tube. He submerged it in a basin of water. He then removed his thumb from the opening of the glass tube.

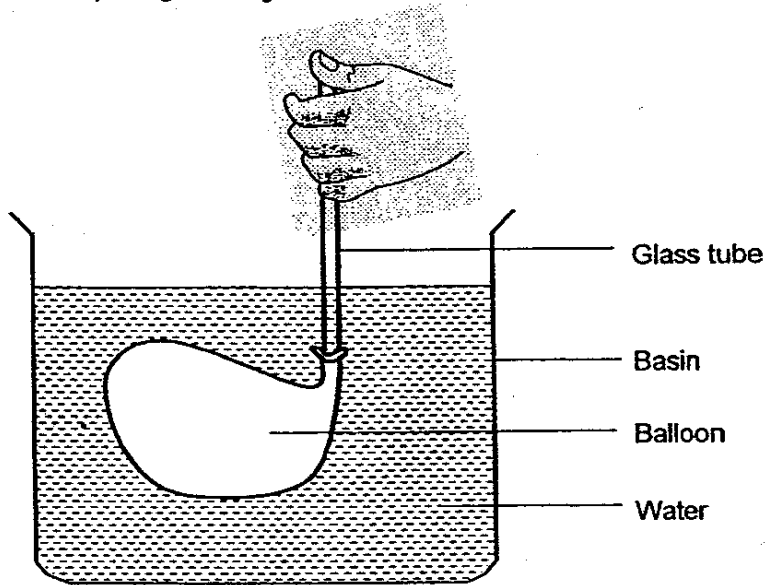

(a) Describe two changes that could be observed when he removed his thumb from the opening of the glass tube. [2]

(i) _____

(ii) _____

(b) Allan repeated the experiment using a balloon that was filled with an equal volume of water. What did he observe when he removed his thumb from the opening of the glass tube? [1]

(Go on to the next page)

SCORE	3
-------	---

- 41 Sally selected four materials A, B, C and D to make some products. She recorded her choices and the corresponding reasons in the table below.

Material	Product and Reason
A	To make swimming floats because it is flexible
B	To make fishing weights because it is <u>heavy</u>
C	To make dresses because it is light and comfortable
D	To make artificial hip joints because it is <u>light but strong</u>

- (a) Which material(s), A, B, C or/and D could be metal(s)? [1]

- (b) Describe how Sally can carry out a test to confirm that Material D is strong. [1]

(Go on to the next page)

SCORE	2
-------	---

42 The diagram shows a classification table for living things.

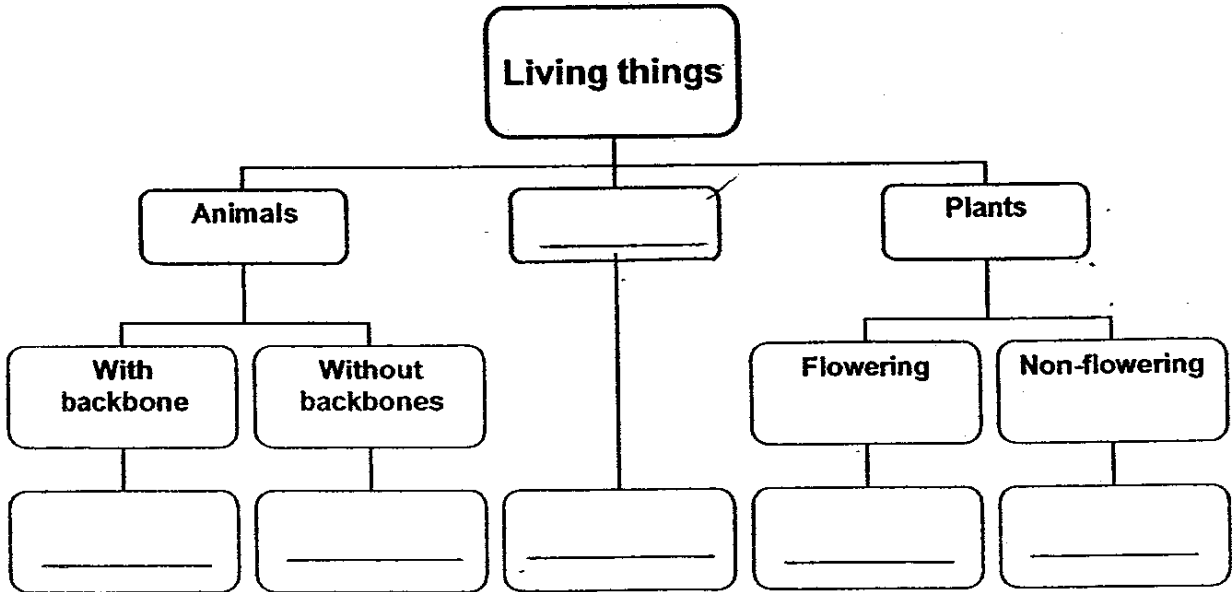

(a) Write "fungi" in the correct box in the classification table. [1]

(b) State the difference in the way that animals and fungi reproduce. [1]

(Go on to the next page)

SCORE	2
-------	---

- 43 The table shows members of Jenny's family and a checklist of whether they have straight or curly hair.

Family member	Straight hair	Curly hair
Maternal Grandfather (Mother's father)		✓
Maternal Grandmother (Mother's mother)	✓	
Father	✓	
Mother		✓
Brother		✓
Jenny	✓	

In the diagram of the family tree below, identify the characteristics of the hair of the following family members:

- Maternal Grandfather
- Father
- Brother
- Jenny

Write 'S' to represent 'straight hair' and write 'C' to represent 'curly hair'. Write the letters inside the boxes and circles.

[2]

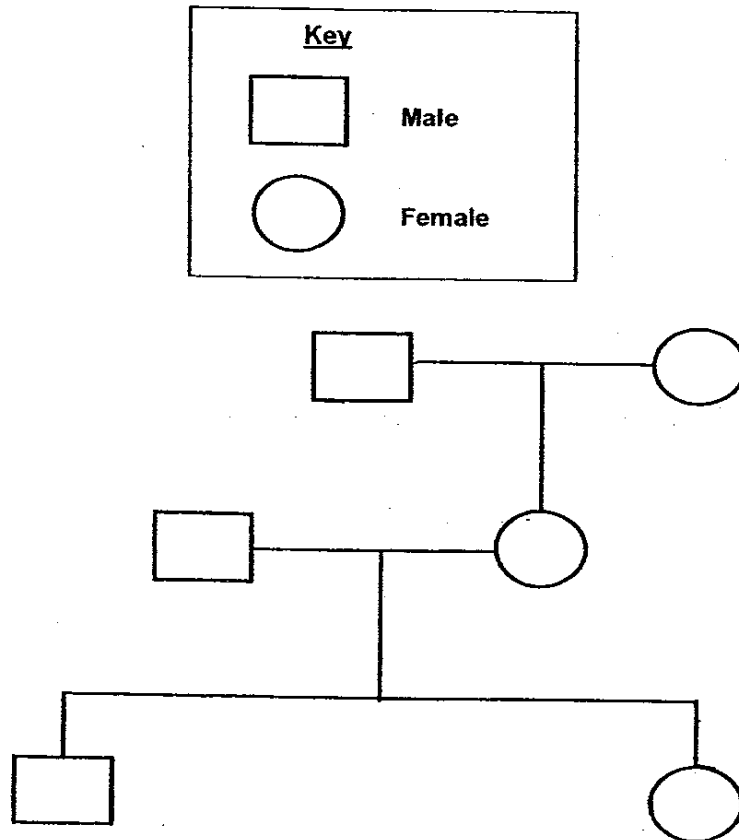

(Go on to the next page)

B - 12

SCORE	2
-------	---

34

44

Li Ting set up an investigation as shown below to find out whether the amount of light affected the rate of bubbles produced by the hydrilla.

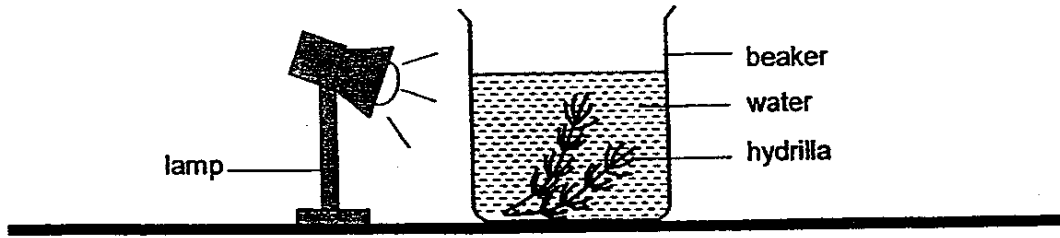

She repeated the investigation, each time increasing the number of lamps and recorded the results in the graph below.

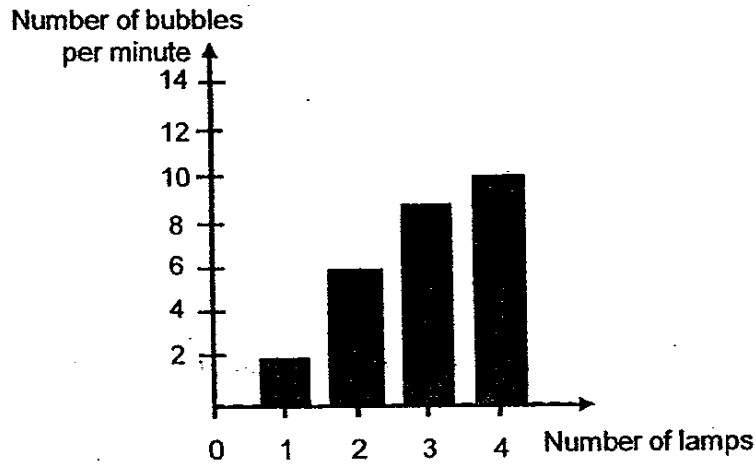

(a) How were the bubbles produced? [1]

(b) What can Li Ting conclude about the relationship between the number of lamps used and the rate of bubbles produced by the hydrilla? [1]

(Go on to the next page)

SCORE	2
-------	---

35

45

Rita wanted to investigate what conditions are necessary for the germination of seeds. She prepared 3 set-ups as shown below and left them in a room with a temperature of 30°C.

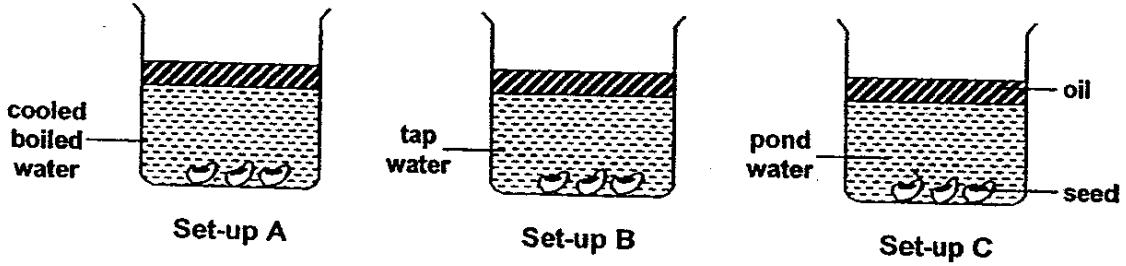

(a) In which set-ups will the seeds germinate? [1]

(b) Explain your answer in (a). [1]

(c) What was the purpose of the layer of oil in each set-up? [1]

(Go on to the next page)

- 46 The diagram shows an open circuit. The 3-way switch is made up of 4 pins S, T, U and V. A clip is connected to Pin V and can be moved to touch pins S, T and U.

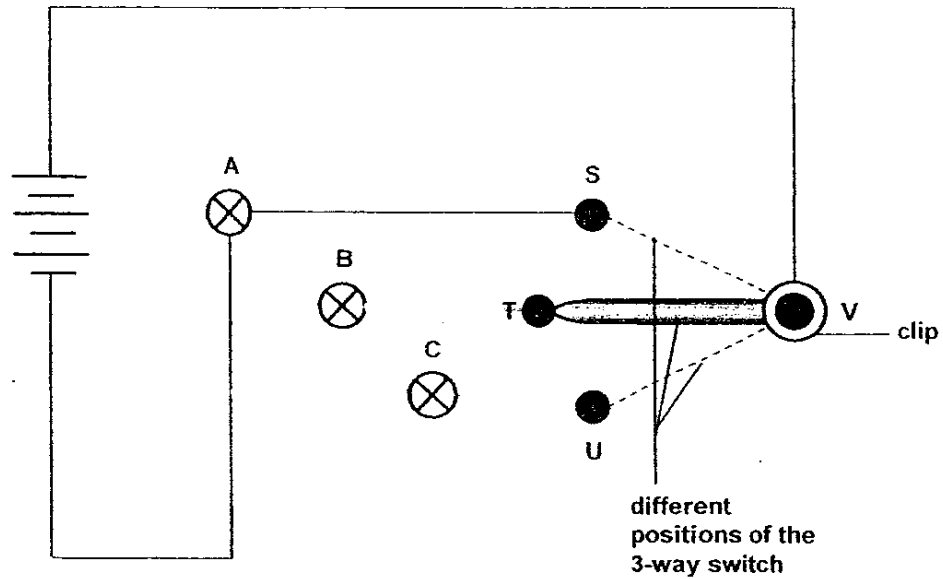

- (a) **Draw in 4 wires in the diagram** to show how the 3-way switch can be connected to the bulbs so that we can move the clip to light up any one of the 3 bulbs. [2]
- (b) What is the disadvantage of using a 3-way switch system in a home? [1]

THE END

SCORE	3
-------	---

37
End

Anglo-Chinese (Junior) Primary School
Primary 6 Science Preliminary Exams (2006)

(ANSWER KEY)

SECTION A : (60 MARKS)

Qn no.	Ans
1	2
2	3
3	3
4	2
5	4
6	3
7	3
8	1
9	1
10	4

Qn no.	Ans
11	1
12	4
13	3
14	2
15	2
16	2
17	1
18	2
19	3
20	2



Qn no.	Ans
21	1
22	2
23	2
24	2
25	1
26	4
27	4
28	2
29	3
30	2

SECTION B (40 MARKS)

Qn No.	Answers
31a	18.5cm
31b	The greater the amount of load und on the spring, the greater the extension of the spring.

32a	B, because like a door knob, B requires a small's effort to overcome a grater load and the distance the effort travels is grater than the distance the load travels.
32b	C, because even the its effort traveled a smaller distance than its load, it still required a smaller effort to lift a greater load when the load should be grater than the effort.

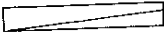
33a	A, because damselfly gills beat only 70 times per minute, therefore proves more oxygen was taken in one beat, and this tells us that sample of water contained the most oxygen.
33b	The two sources are aquatic plants and the air just above the water surface,

Qn No.	Answers
34a	A)  B) 
34b	The object does not allow light to pass through it.

35a	The milk is heated to get rid of any harmful bacteria.
35b	The bacteria are added after the milk has cooled to 28°C.
35c	28°C

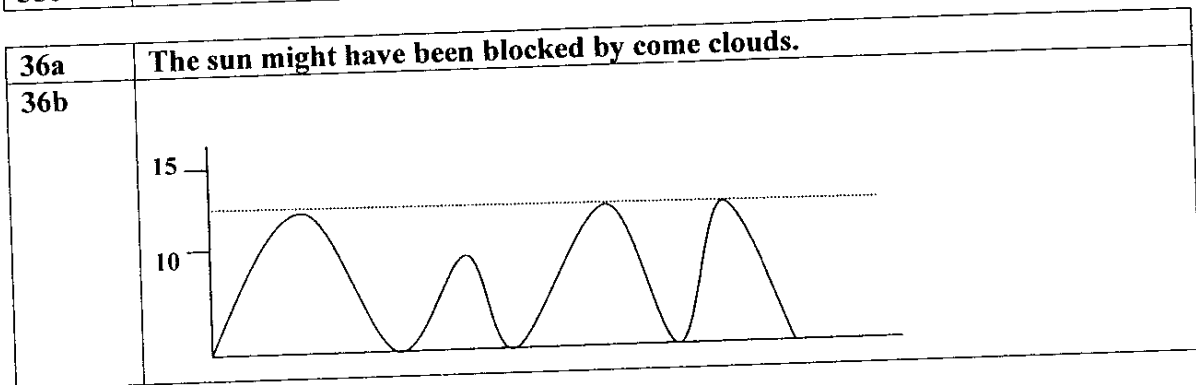

37a	No, because the materials are placed at different distance from the candle.
37b (i)	No
(ii)	True

38a (i)	He would use this to measure the amount of water to pour into each soil sample.
(ii)	Measure the time taken for a fixed amount of water to flow out from the soil.
38b	The dead organisms, when decomposed, provide nutrients for the plants.

39a	Pollination and Fertilisation.
39b	The seed leaves will shrivel.
39c	The mature adult plant should disperse its seed over a large area.

40a (i)	The balloon would deflate.
(ii)	The water level in the basin would decrease.
40c	The balloon remains the same and the water would not change.

Qn No.	Answers
41a	B and D
41b	She should test how much weight it can withstand before it bends and compare it with materials.

42a	Animals, Fungi, Plants
42b	Animals reproduce by giving birth to young alive or by eggs, whereas fungi reproduce by spores

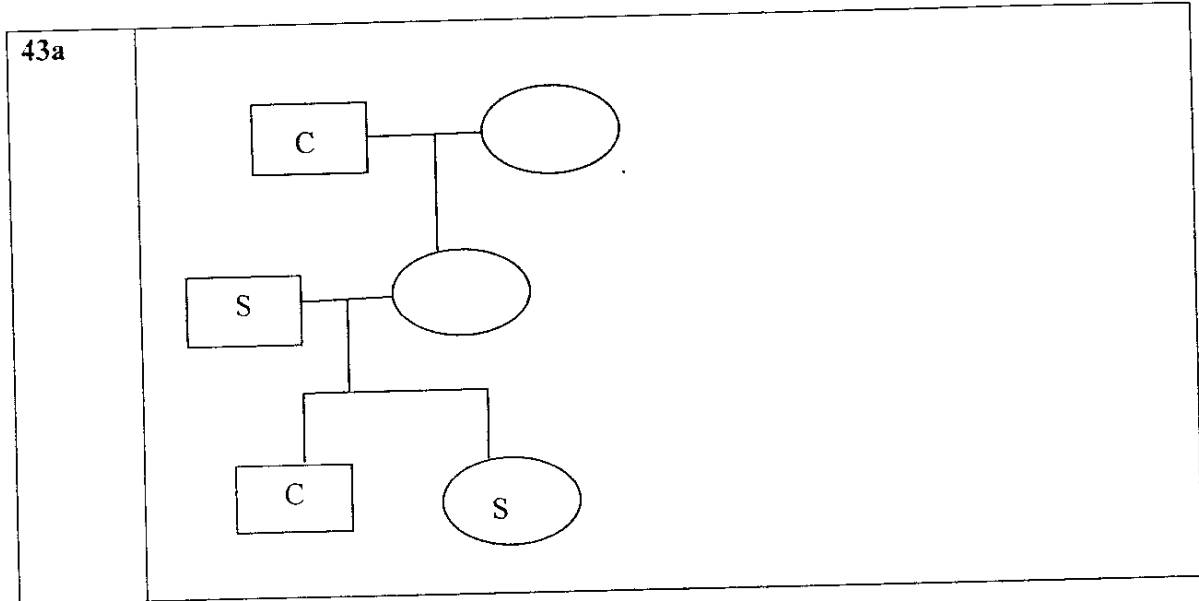

44a	The bubble was produced when the hydrilla took in carbon dioxide and water in the presence of light during photosynthesis and gave out oxygen.
44b	The greater the number of lamps, the faster the rate of bubbles produced by hydrilla.

45a	Set-up C and B
45b	Oxygen present in tap water and pond water but not present in the cooled boiled water.
45c	To ensure no oxygen enters the different types of water from the surrounding air.

46a

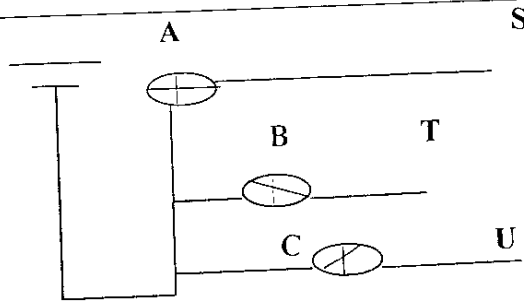

46b

The disadvantage is that you cannot switch on all the bulbs at one time.