

Index No.

|  |  |  |  |  |  |  |  |  |  |
|--|--|--|--|--|--|--|--|--|--|
|  |  |  |  |  |  |  |  |  |  |
|--|--|--|--|--|--|--|--|--|--|

ANGLO-CHINESE SCHOOL (JUNIOR)  
ANGLO-CHINESE SCHOOL (PRIMARY)



COMBINED PRELIMINARY EXAMINATION 2010

SCIENCE

BOOKLET A

Friday

27 August 2010

1 hour 45 minutes

NAME \_\_\_\_\_ (     )

CLASS : P6. \_\_\_\_\_

INSTRUCTIONS TO PUPILS

DO NOT TURN OVER THE PAGES UNTIL YOU ARE TOLD TO DO SO

Follow all instructions carefully.

There are 30 questions in this booklet.

Answer ALL questions.

INFORMATION FOR PUPILS

The total marks for this booklet is 60.

The total time for Booklets A and B is 1 hour 45 minutes.

This question paper consists of 16 printed pages. (Inclusive of cover page)

For each question from 1 to 30, four options are given. One of them is the correct answer. Make your choice (1, 2, 3 or 4). Shade your answer on the Optical Answer Sheet.

(60 marks)

1 Which one of the following examples of structural and behavioral adaptations is correct?

| Structural Adaptation  | Behavioral Adaptation   |
|--|---|
| <del>X</del> Wolves have sharp teeth to tear the flesh of their prey.    | Wolves hunt in groups to capture prey that is larger.                 |
| <del>X</del> Eagles have claws to catch and grab their prey.             | Eagles have sharp eye-sight to help them see their prey from the sky. |
| <del>X</del> Polar bears hide and rest during winter to conserve energy. | Polar bears have a keen sense of smell to detect prey from far away.  |
| <del>X</del> Camels hide in the shade to avoid the Sun's heat.           | Camels hunt for food at night to avoid the Sun's heat.                |

2

Hashim conducted a study on the type and number of animals he found in a rotting log community and a leaf litter community. He then constructed two pie charts as shown below.

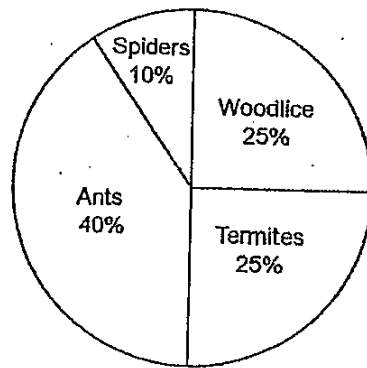

Rotting Log Community

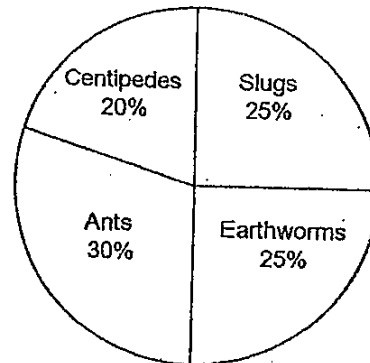

Leaf Litter Community

Based on the information above, which of the following statement(s) is/are true?

~~A~~  
~~B~~  
~~C~~  
~~D~~

- A There are fewer spiders than termites in the rotting log community.
- B The centipedes in the leaf litter community prey on earthworms only.
- C All the organisms in each of the community can form a single food chain.
- D There are more ants in the rotting log community than in the leaf litter community.

- (1) A only
- ~~(2)~~ B and C only
- ~~(3)~~ A, C and D only
- ~~(4)~~ A, B, C and D

- 3 The graph below shows the amount of waste disposed by a small city from year 2001 to 2009.

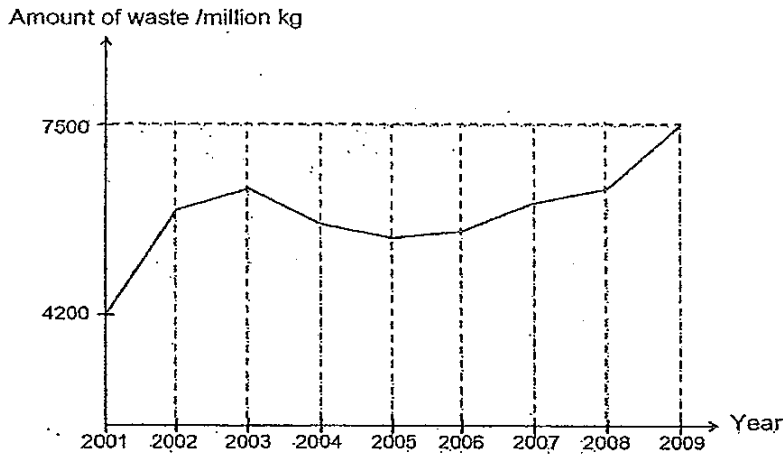

Based on the data above only, which of the following statement(s) is/are correct?

- A The amount of waste disposed was the least in 2005.
- B The amount of waste disposed shows an increasing trend from 2005 to 2009.
- C The amount of waste disposed decreased from 2003 to 2005 because of a successful recycling campaign in the city.

- (1) A only
- (2) B only
- (3) B and C only
- (4) A, B and C

- 4 The picture below shows a boy trying to push a box across the floor in the direction represented by the arrow.

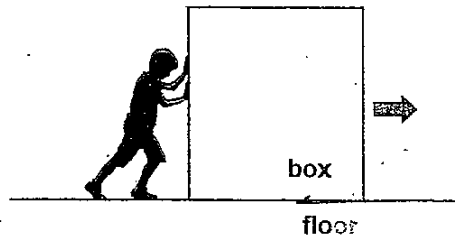

Which of the following way(s) will help the boy push the box across the floor using less force?

- A Increase the mass of the box.
- B Add rollers between the box and the floor.
- C Get another boy to push harder in the opposite direction.
- D Add a layer of oil between the box and the hands of the boy.

- (1) B only
- (2) D only
- (3) A and C only
- (4) B and D only

- 5 Sammy collected some water specimens from four different ponds, A, B, C and D. He wanted to find out how clear the water in these ponds were and set up his experiment as shown below.

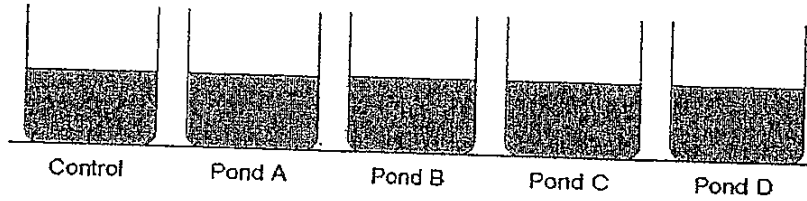

To measure the clarity of the water, he shines a torch from one side of the beaker to the light sensor on the opposite side as shown below. The datalogger then records the intensity of light.

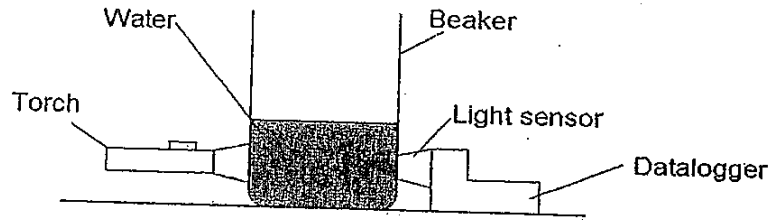

The results are tabulated in the table as shown.

|                                     | Pond A | Pond B | Pond C | Pond D |
|-------------------------------------|--------|--------|--------|--------|
| Intensity of light recorded (units) | 1500   | 2000   | 300    | 1000   |

From Sammy's experiment, arrange the clarity of the water in ponds A, B, C and D in descending order.

- (1) A, B, C, D
- (2) B, A, D, C
- (3) B, D, A, C
- (4) C, D, B, A

- 6 The food web below shows the relationship among 6 organisms, P, Q, R, S, T and U in a habitat.

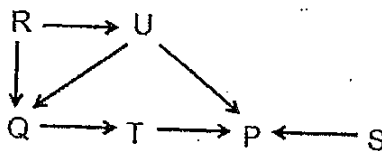

Based on the information above, which of the following shows the correct classification of the organisms?

|                                     | Herbivores | Carnivores    | Omnivores |
|-------------------------------------|------------|---------------|-----------|
| <input checked="" type="checkbox"/> | Q          | T and U       | P and S   |
| <input checked="" type="checkbox"/> | R and S    | P, Q, T and U | None      |
| <input checked="" type="checkbox"/> | U          | T             | P and Q   |
| <input checked="" type="checkbox"/> | S and U    | T and Q       | P         |

- 7 Alan wants to find out whether the number of batteries affects the strength of an electromagnet. Which two arrangements below should he set up to conduct a fair test?

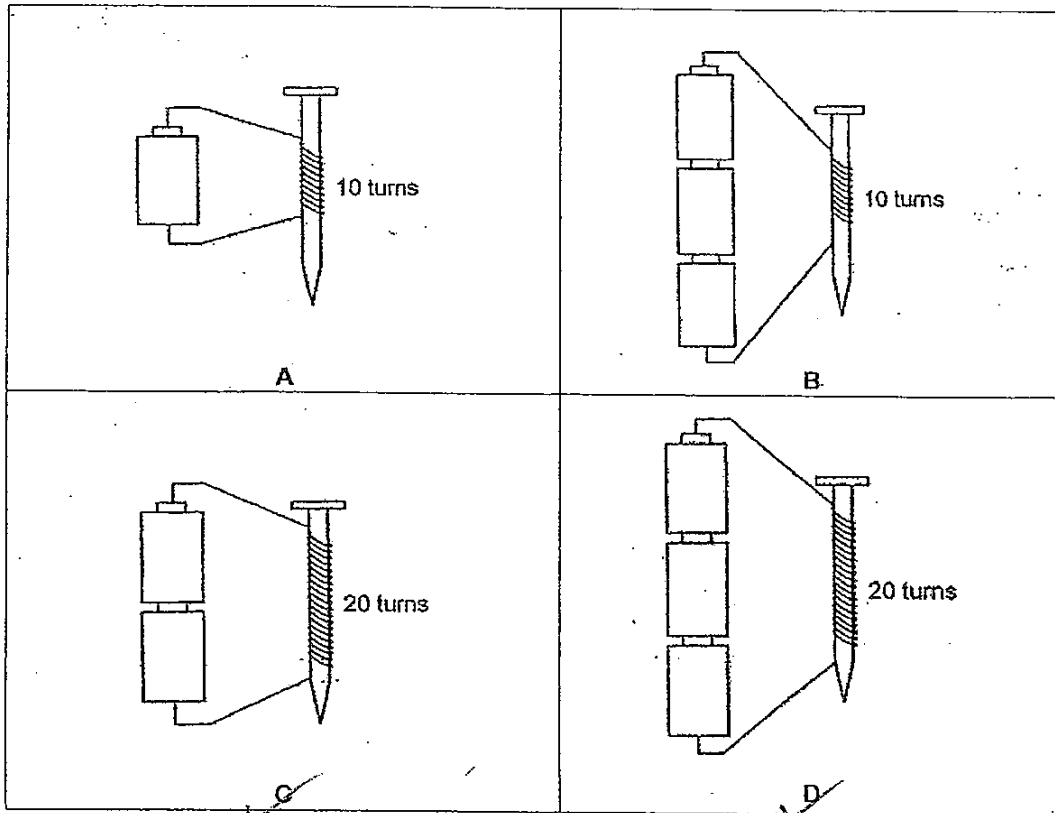

- ~~(1)~~ A and B  
~~(2)~~ A and C  
~~(3)~~ B and C  
~~(4)~~ B and D

- 8 The picture below shows a huge electromagnet that is used in scrap yards to separate the magnetic metals from the non-magnetic metals and non-metals.

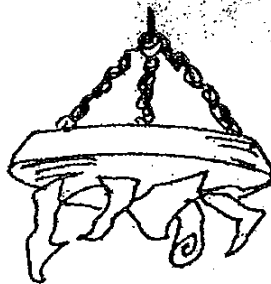

Which one of the following items will be attracted by the electromagnet?

- ~~(1)~~ Iron rod  
~~(2)~~ Glass bottle  
~~(3)~~ Wooden stick  
~~(4)~~ Aluminium can

- 9 The diagrams below show the stages in the life cycle of a mosquito and a butterfly.

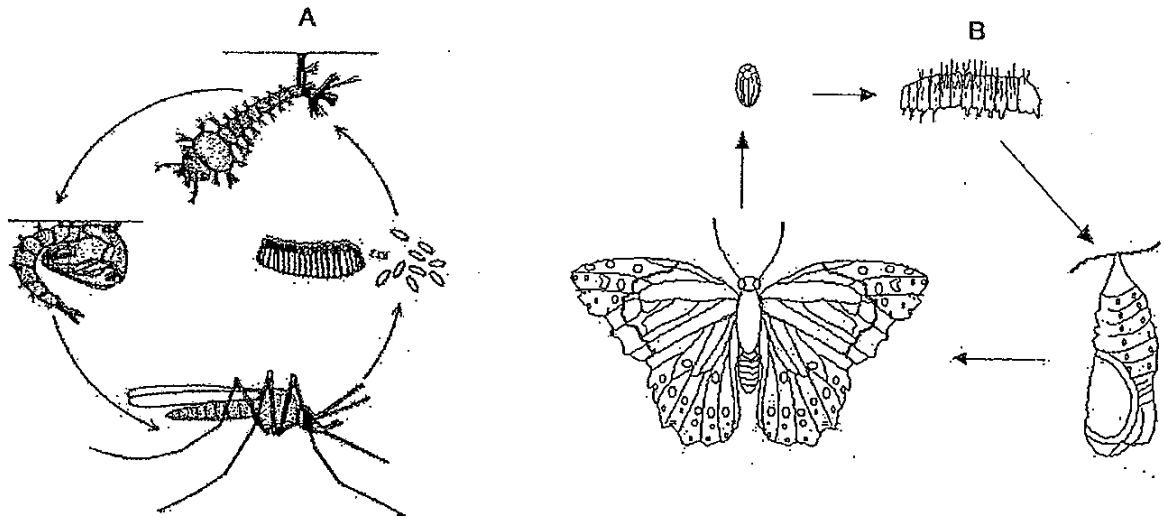

In what way(s) are the two organisms at stages A and B as shown above similar?

- P They live in water.
- Q They undergo moulting.
- R They move about freely.
- S They hatched from eggs.

- Q only
- R only
- P and S only
- Q, R and S only

- 10 Simon completely filled two identical syringes, one with air while the other with water, and covered them with black paper as shown in the diagram below.

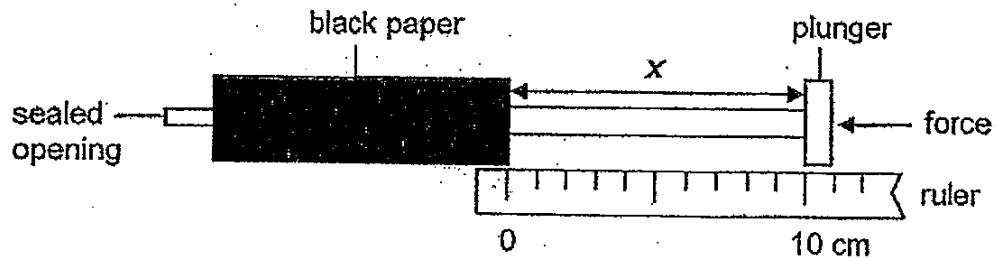

He then pushed each plunger as hard as he could and measured the distance  $x$ . Which one of the following shows the correct values of  $x$ ?

| Syringe with water<br>$x / \text{cm}$  | Syringe with air<br>$x / \text{cm}$ |
|--|-------------------------------------|
| <input checked="" type="checkbox"/> 10 | 0                                   |
| <input checked="" type="checkbox"/> 0  | 10                                  |
| <input checked="" type="checkbox"/> 10 | 7                                   |
| <input checked="" type="checkbox"/> 7  | 10                                  |

- 11 The table below shows some of the physical characteristics of Vivek and his parents.

|          | Physical Characteristics |            |          |             |
|----------|--------------------------|------------|----------|-------------|
|          | Eyes                     | Eyelids    | Earlobes | Hair Length |
| Vivek    | brown   f                | single   m | detached | short       |
| Mr Bala  | brown                    | double     | attached | short       |
| Mrs Bala | grey                     | single     | attached | long        |

Which one of the following statements is true?

- ~~(1)~~ He inherited all the characteristics from his father.  
~~(2)~~ He inherited one characteristic from his father and two from his mother.  
~~(3)~~ He inherited one characteristic from his father and one from his mother.  
~~(4)~~ He inherited two characteristics from his father and one from his mother.

- 12 Which of the following statements about sexual reproduction in both animals and plants are true?

- ~~A~~ Fertilisation occurs.  
~~B~~ The sperm fuses with the egg.  
~~C~~ The eggs are released from the ovules.  
~~D~~ The male and female sex cells are required.

- ~~(1)~~ A and B only  
~~(2)~~ A and D only  
~~(3)~~ B, C and D only  
~~(4)~~ A, B, C and D

- 13 Yanti would like to investigate how the amount of heat affects the temperature of water. A beaker, filled with 500 ml of water at room temperature, was heated to boiling point for 10 minutes. The beaker of boiling water continued to be heated for another 10 minutes. She used a laboratory thermometer to record the temperature of the water at a certain time interval.

Which one of the following tables shows the most likely temperature of the water during this time interval?

|  | Time interval |                      |                      |
|--|---------------|----------------------|----------------------|
|  | Start         | 10 <sup>th</sup> min | 20 <sup>th</sup> min |
| <del>(1)</del> Temperature of water / °C | 25            | 100                  | 110                  |
| <del>(2)</del> Temperature of water / °C | 25            | 80                   | 100                  |
| <del>(3)</del> Temperature of water / °C | 25            | 100                  | 100                  |
| <del>(4)</del> Temperature of water / °C | 25            | 110                  | 100                  |

- 14) 4 similar glasses, P, Q, R and S, were each filled with 50ml of water at different temperatures and placed in the same room at 25°C as shown in the diagram below. Which glass(es) will have water droplets forming on the outer surface of the glass(es) after some time?

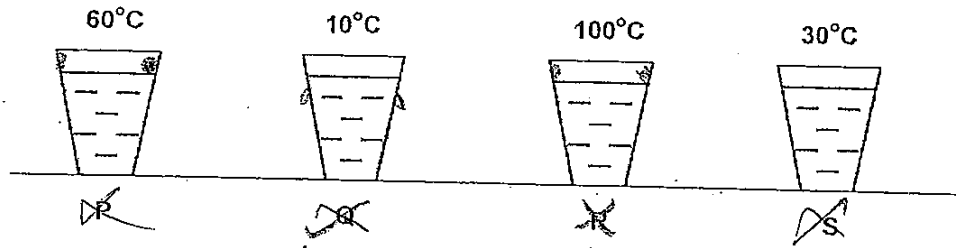

- (1) Q only  
 (2) R only  
 (3) P and Q only  
 (4) P, R and S only

- 15) A group of 4 pupils are discussing the possible ways to conserve water as shown by their statements below.

**Angie** : I let the tap run while brushing my teeth.  
**Bala** : I take showers often to cool myself due to the hot weather.  
**Caili** : I reuse the water used to wash vegetables to flush the toilet.  
**Dollah** : I use a watering can instead of a hose to water my family's plants.

Who is / are more or most likely to be conserving water?

- (1) Bala only  
 (2) Caili only  
 (3) Angie and Bala only  
 (4) Caili and Dollah only

- 16) Which of the following sources of energy are renewable?

- A. Coal  
 B. Wind  
 C. Natural gas  
 D. Running Water

- (1) A and C only  
 (2) B and D only  
 (3) A, B and D only  
 (4) B, C and D only



- 17 Robert placed a torch at position K. The torch shone at the object that was placed at position M as shown below. A shadow was cast on the screen.

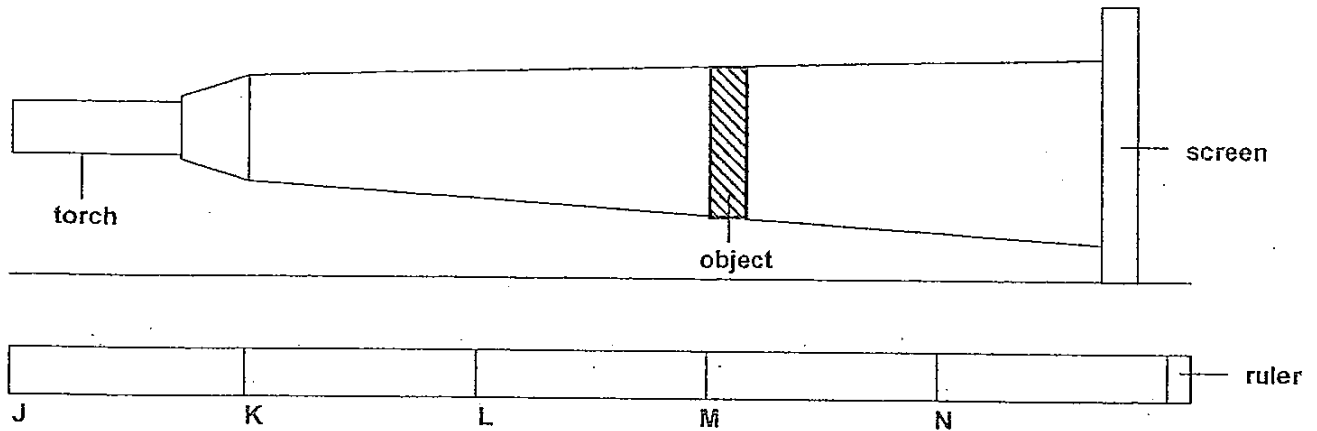

At which positions of the ruler should the torch and the object be placed so as to obtain a smaller shadow on the screen than before?

|                                       | Position of torch | Position of object |
|---------------------------------------|-------------------|--------------------|
| <input checked="" type="checkbox"/> A | K                 | N                  |
| <input checked="" type="checkbox"/> B | J                 | K                  |
| <input type="checkbox"/> C            | L                 | M                  |
| <input checked="" type="checkbox"/> D | J                 | N                  |

- (1) A and C only  
 (2) A and D only  
 (3) B and C only  
 (4) B and D only

- 18 Samuel classified the energy that the following objects possess into 3 groups, P, Q and R. There are 2 objects in each group.

A bottle of petrol  
 A cup of ice cream  
 Moving water in a river  
 Compressed spring in a toy  
 Rolling a ball on a flat ground  
 A stretched rubber band in a catapult

Which one of the following correctly represents the most likely headings for groups P, Q and R?

|   | P                         | Q                        | R              |
|---|---------------------------|--------------------------|----------------|
| <input checked="" type="checkbox"/> (1) | Chemical Potential Energy | Sound Energy             | Kinetic energy |
| <input checked="" type="checkbox"/> (2) | Chemical Potential Energy | Elastic Potential Energy | Heat Energy    |
| <input checked="" type="checkbox"/> (3) | Heat Energy               | Elastic Potential Energy | Kinetic energy |
| <input checked="" type="checkbox"/> (4) | Chemical Potential Energy | Elastic Potential Energy | Kinetic energy |

19 Which of the following are sources of potential energy?

- A Battery
- B Compressed air in a rifle
- C Water stored in the rooftop tank of a building

- (1) A and B only
- (2) A and C only
- (3) B and C only
- (4) A, B and C

20 Craig heated some water in a beaker until it boiled. He continued to allow the water to boil for some time. It was then left on a table to cool. He recorded the results in the graph as shown below.

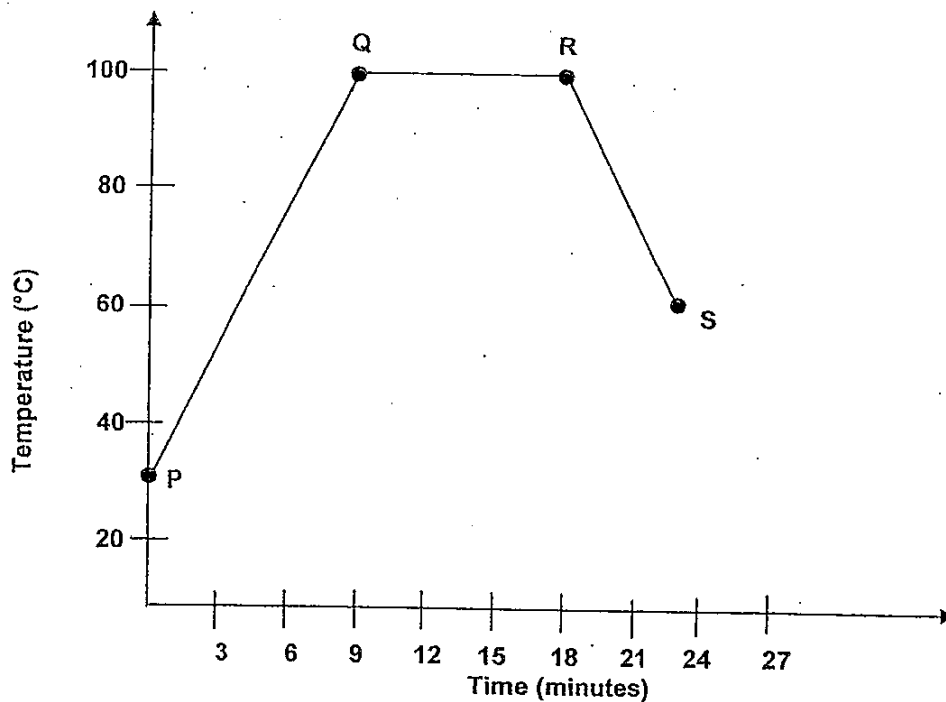

Which of the following statements correctly show what happened to the water at the different stages?

- A Heat is gained during Q to R.
- B Water was heated for 18 minutes.
- C Water exists in 2 states between P and Q.
- D Evaporation takes place only at R to S only.

- (1) A and B only
- (2) B and C only
- (3) A, B and C only
- (4) A, B, C and D only

- 21 Naufal conducted an experiment with a wound-up toy. At each try, he only changed the number of turns of the key and measured the distance travelled by the toy upon release.

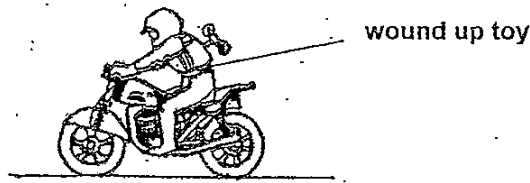

Which of the following are possible aims for the above experiment?

- A To find out if the mass of the toy affects the distance moved by the toy.
- B To find out if the number of turns of the key affects the distance travelled by the toy.
- C To find out if the surface the toy travels on affects the distance travelled by the toy.
- D To find out if the potential energy gained by winding up the toy affects the kinetic energy in the toy.

- (1) B only
- (2) A and C only
- (3) B and D only
- (4) C and D only

- 22 Look at the set-up below. The paper spiral began to spin soon after the circuit was connected below.

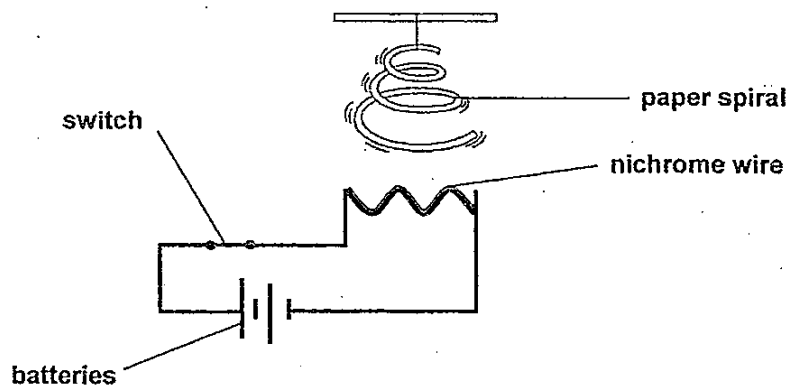

Which one of the following correctly describes the energy changes from the time the switch was closed till the time the spiral began to spin?

- (1) electrical energy → heat energy + light energy → kinetic energy
- (2) electrical energy → kinetic energy → heat energy + light energy
- (3) chemical potential energy → electrical energy → kinetic energy + heat energy
- (4) chemical potential energy → electrical energy → heat energy + light energy → kinetic energy

23 The chart below shows how materials W and Y are classified.

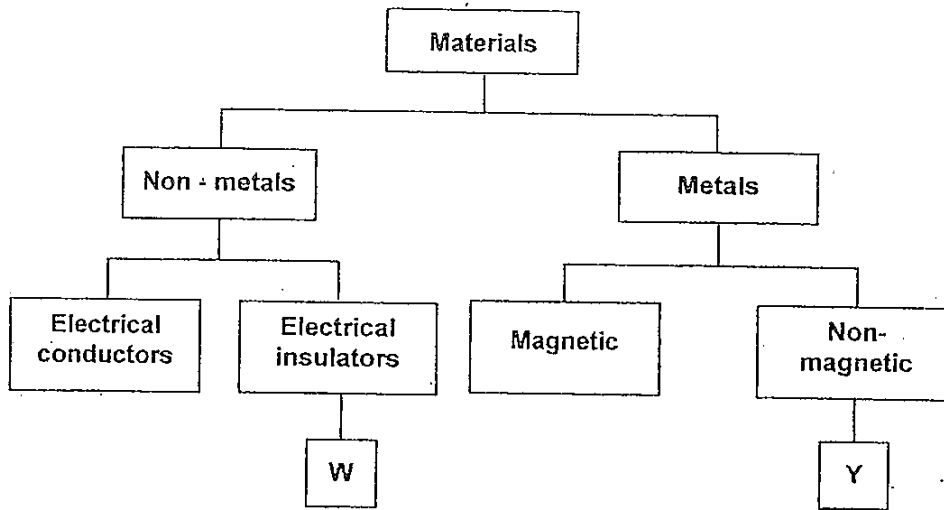

Which of the following materials could W and Y be?

| W                      | Y         |
|------------------------|-----------|
| <del>(1)</del> ceramic | cobalt    |
| <del>(2)</del> rubber  | silver    |
| <del>(3)</del> gold    | aluminium |
| <del>(4)</del> wood    | steel     |

24 Study the flowchart below.

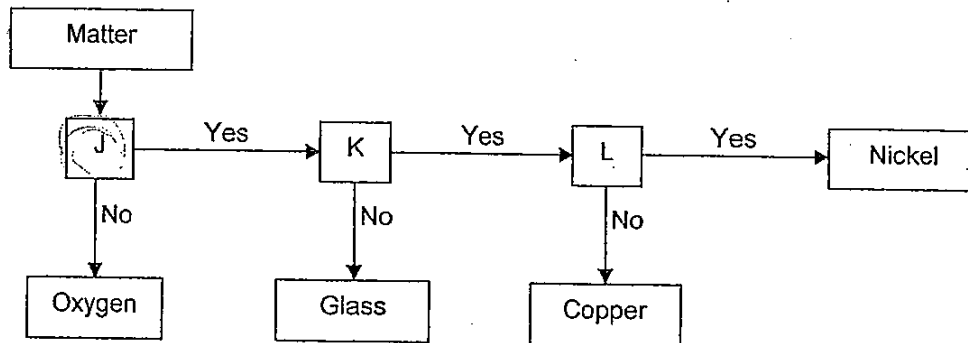

Which of the following are suitable questions that can be represented by J, K and L?

| J   | K                            | L                            |
|---|------------------------------|------------------------------|
| <del>(1)</del> Does it conduct electricity? | Is it magnetic?              | Is it a solid?               |
| <del>(2)</del> Is it a solid?               | Does it conduct electricity? | Is it magnetic?              |
| <del>(3)</del> Is it magnetic?              | Does it conduct electricity? | Is it a solid?               |
| <del>(4)</del> Is it magnetic?              | Is it a solid?               | Does it conduct electricity? |

25

Alexander carried out an experiment in a dark room as shown in the diagram below. He first exposed a stalk of hydrilla to a lit light bulb connected to 1 battery. After 4 hours, he measured the volume of oxygen collected in the test-tube.

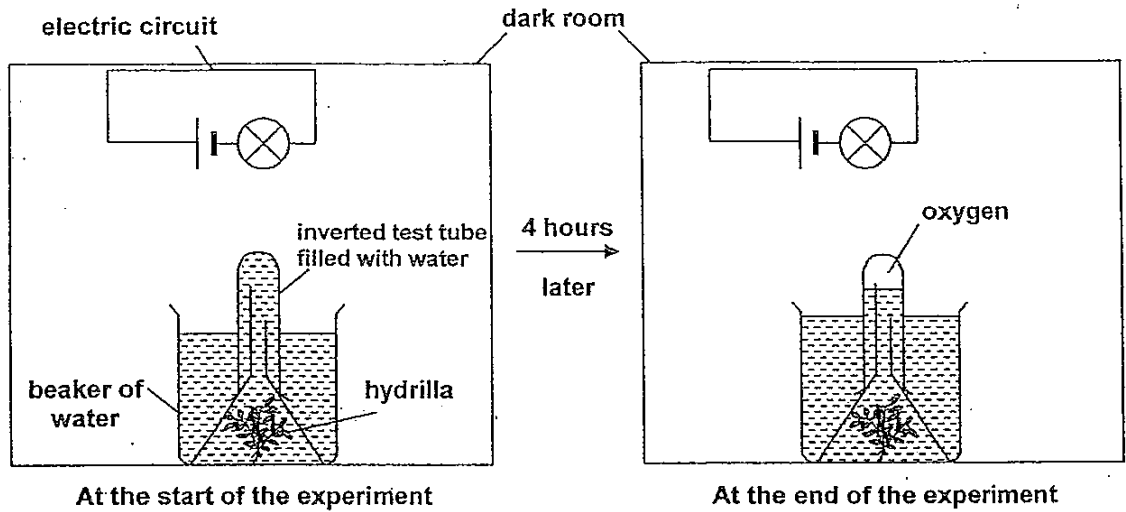

He then repeated the whole experiment using different number of batteries. The batteries used were new and identical and they were arranged in series.

Which one of the following graphs best represents the amount of oxygen collected when using different number of batteries?

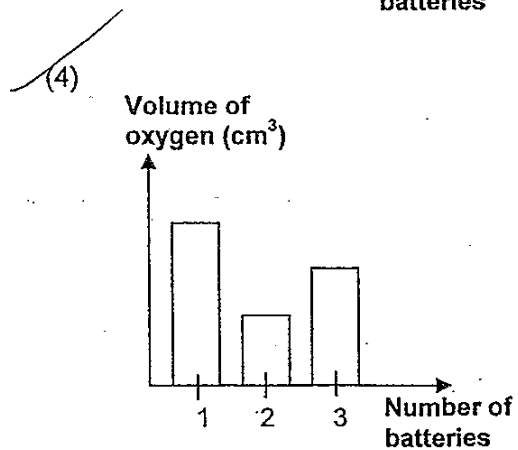
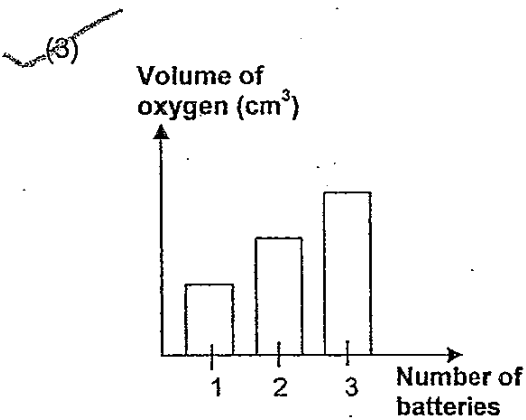
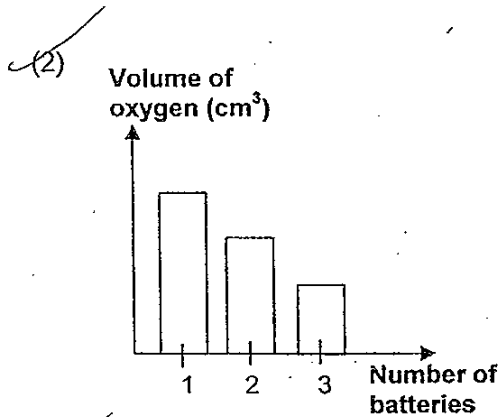
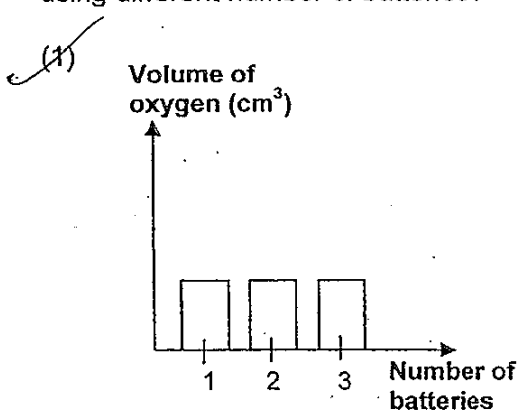

- 26 The table below shows how the blood types of donors and recipients are compatible. A tick (✓) indicates that the blood from the donor can be safely accepted by the recipient.

| Blood type of recipient | Blood type of donor |   |    |   |
|-------------------------|---------------------|---|----|---|
|                         | A                   | B | AB | O |
| A                       | ✓                   |   |    | ✓ |
| B                       |                     | ✓ |    | ✓ |
| AB                      | ✓                   | ✓ | ✓  | ✓ |
| O                       |                     |   |    | ✓ |

The blood type of Jackie and his family members are shown in the table below.

| Person     | Father | Mother | Brother | Sister | Jackie |
|------------|--------|--------|---------|--------|--------|
| Blood type | B      | A      | AB      | O      | B      |

If Jackie needs a blood transfusion, who can he safely receive blood from?

- (1) Father only  
 (2) Father and sister only  
 (3) Brother and sister only  
 (4) Father, brother and sister only

- 27 The diagram below shows some processes taking place between plants and animals.

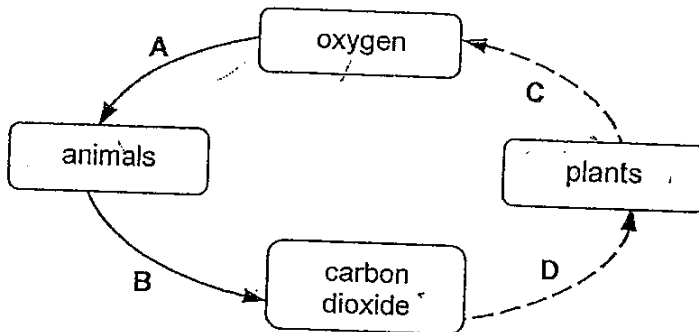

Which of the following best represents the processes (A, B, C and D) involved in this interaction?

|     | A and B        | C and D        |
|-----|----------------|----------------|
| (1) | decomposition  | decomposition  |
| (2) | breathing      | photosynthesis |
| (3) | photosynthesis | photosynthesis |
| (4) | breathing      | decomposition  |

- 28 The diagram below shows a simplified diagram of the human circulatory system. The arrows represent the direction of blood flow in the blood vessels.

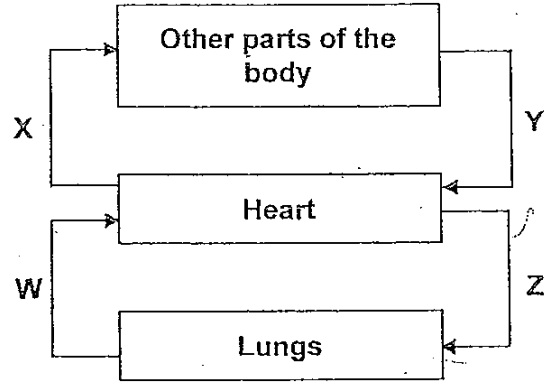

Which pair of blood vessels contains blood rich in carbon dioxide?

- (1) X and Y
- (2) Y and Z
- (3) W and X
- (4) W and Z

- 29 The diagrams below show the cross-section of a stem and part of the human circulatory system.

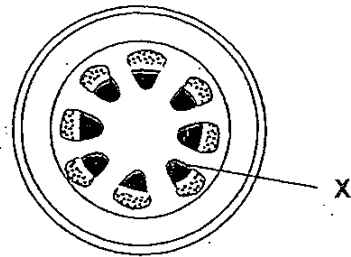

cross-section of stem

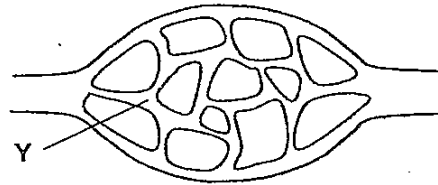

part of human circulatory system

Which of the following is a function of both X and Y?

- (1) Transports food
- (2) Transports water
- (3) Keeps the organism firm
- (4) Allows for gaseous exchange

30 Brandon drew the diagram below to show how sugar and water are transported to and from different parts of the plant represented by J, K and L.

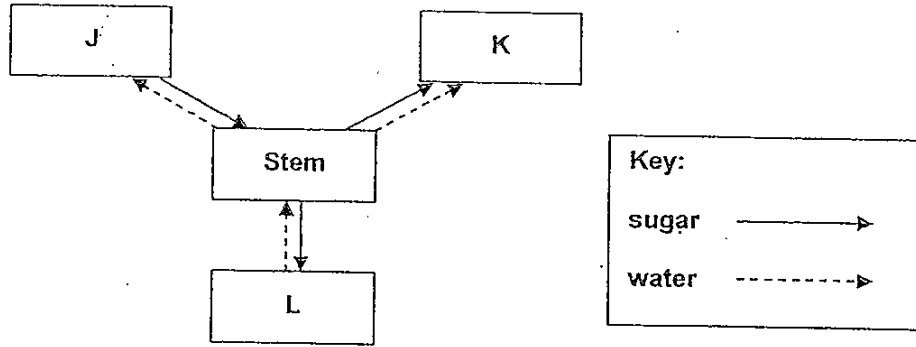

Which of the following parts of the plant are best represented by J, K and L?

|                | J      | K      | L      |
|----------------|--------|--------|--------|
| <del>(1)</del> | fruits | leaves | roots  |
| <del>(2)</del> | leaves | roots  | fruits |
| <del>(3)</del> | roots  | leaves | fruits |
| <del>(4)</del> | leaves | fruits | roots  |



Index No.

|  |  |  |  |
|--|--|--|--|
|  |  |  |  |
|--|--|--|--|

ANGLO-CHINESE SCHOOL (JUNIOR)  
ANGLO-CHINESE SCHOOL (PRIMARY)



COMBINED PRELIMINARY EXAMINATION 2010

SCIENCE

BOOKLET B

Friday

27 August 2010

1 hour 45 minutes

NAME \_\_\_\_\_ (     )

CLASS : P6. \_\_\_\_\_

INSTRUCTIONS TO PUPILS

DO NOT TURN OVER THE PAGES UNTIL YOU ARE TOLD TO DO SO

Follow all instructions carefully.

There are 14 questions in this booklet.

Answer **ALL** questions.

INFORMATION FOR PUPILS

The number of marks is given in brackets [ ] at the end of each question or part question.

The total marks for this booklet is 40.

The total time for Booklets A and B is 1 hour 45 minutes.

This question paper consists of 16 printed pages. (Inclusive of cover page)

|                           |       |
|---------------------------|-------|
| BOOKLET A                 | / 60  |
| BOOKLET B                 | / 40  |
| TOTAL                     | / 100 |
| Parent's signature/ Date: |       |

For questions 31 to 44, write your answers in this booklet.

The number of marks available is shown in brackets [ ] at the end of each question or part question.

(40 marks)

- 31 Jonathan used the set-up below to heat some seawater in a beaker until it boiled. A metal sheet was then placed over the beaker. After 15 minutes, he noticed that some droplets were formed at the bottom surface of the metal sheet and these droplets were collected in a cup as shown below.

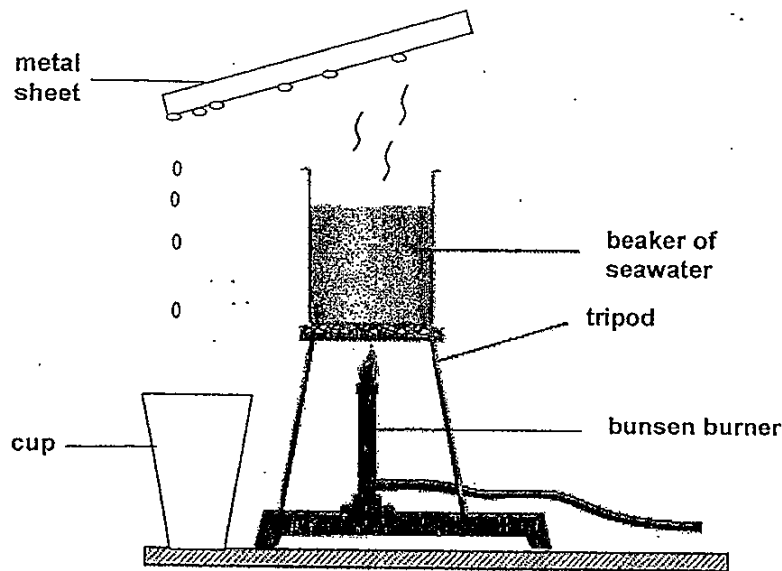

- (a) What was collected in the cup? [1]
- \_\_\_\_\_
- (b) State the processes which cause the formation of these droplets. [1]
- \_\_\_\_\_
- (c) Explain why, after some time, there were less droplets forming on the metal sheet. [2]
- \_\_\_\_\_
- \_\_\_\_\_

(Go to the next page)

|       |   |
|-------|---|
| Score | 4 |
|-------|---|

32 The diagrams below show the reproductive parts of a Tree fern and a Dandelion plant.

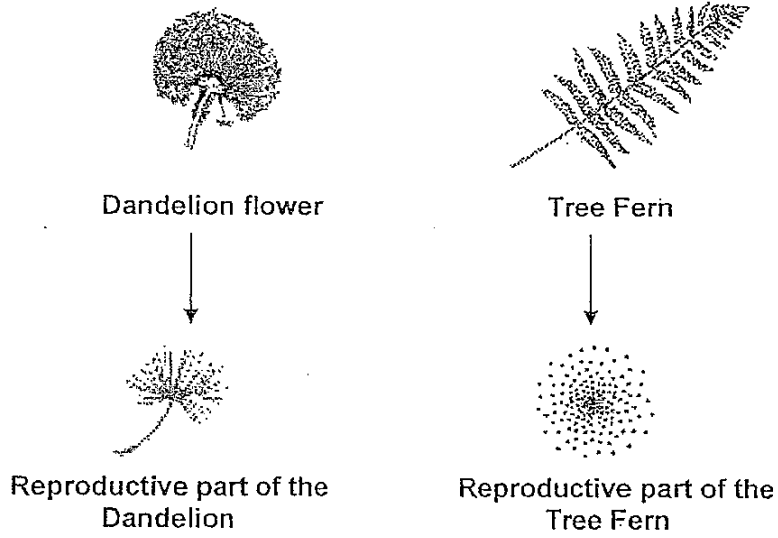

(a) Based on the diagrams, what is the most likely method of dispersal for both plants? [1]

---

(b) State two common features of the reproductive parts of both plants that help them in their dispersal. [1]

---

(c) The diagram below shows the reproductive parts (A) and (B) of two other plants that have special structures to help them in their dispersal.

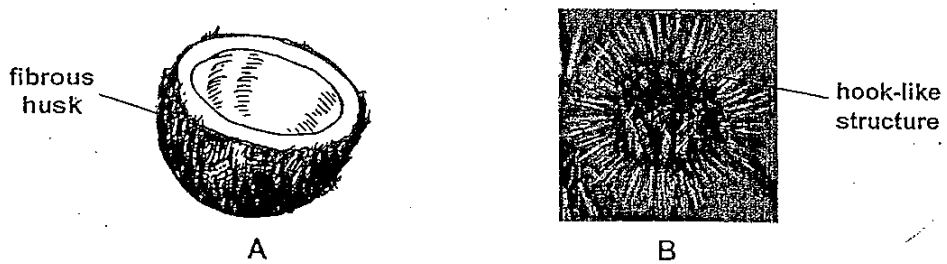

How are they different in their method of dispersal? [1]

---



---

(Go to the next page)

|       |   |
|-------|---|
| Score | 3 |
|-------|---|

- 33 Robert had a spring which is 8cm long. He hung a 20g weight on it and the total length became 10cm. He added another 20g mass and the total length became 12cm. He continued to add 20g mass up to a maximum of 100g and recorded the respective total length of the spring.

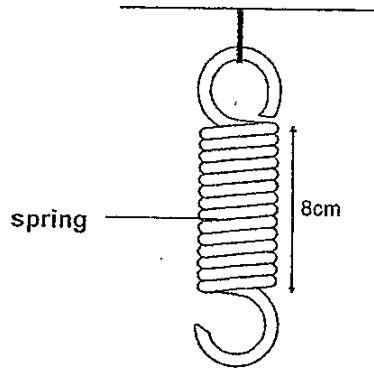

- (a) Draw a line graph based on all the information given for mass up to 100g. [2]  
 (b) Give a suitable heading for the Y-axis. [1]

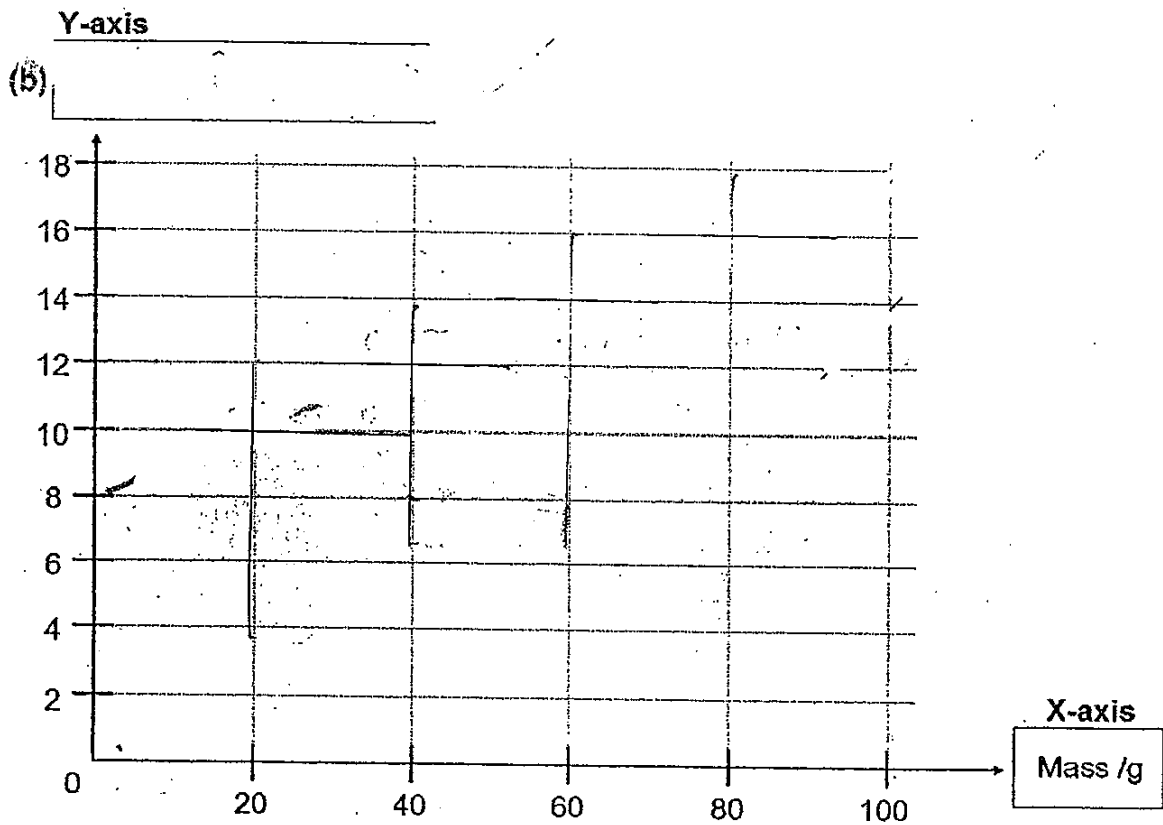

(Go to the next page)

|       |   |
|-------|---|
| Score | 3 |
|-------|---|

- 34 Raymond wanted to find out if feathers can insulate heat in a container. He set up the experiment as shown below.

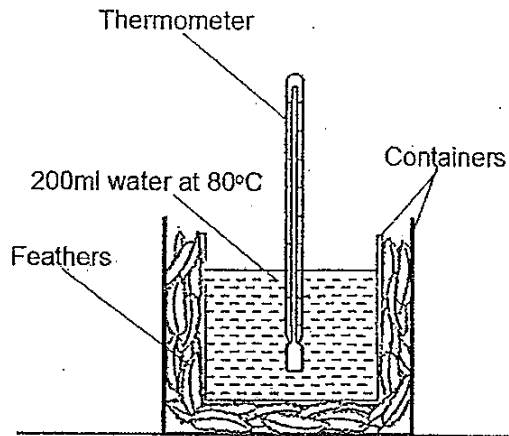

- (a) Draw and label the control set-up in the box below so that Raymond's experiment is a fair one. [1]

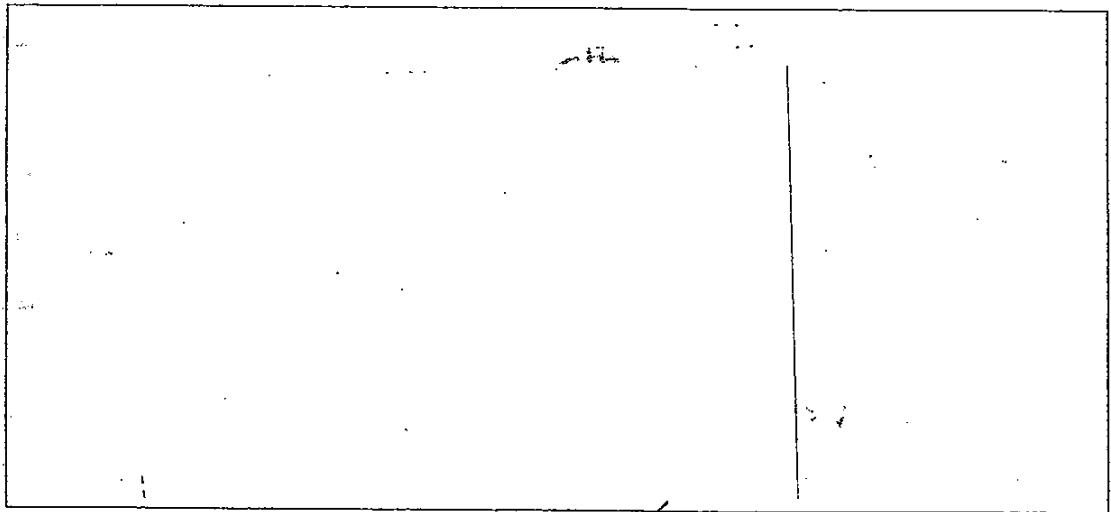

- (b) Birds have feathers to keep them warm and help them fly. State another adaptation of birds and explain how this adaptation helps them fly. [2]

\_\_\_\_\_

\_\_\_\_\_

(Go to the next page)

|       |   |
|-------|---|
| Score | 3 |
|-------|---|

- 35 The diagram below shows a picture of a toy. Both the toy and the sphere have magnets inside them. The sphere appears to be 'floating' in the air.

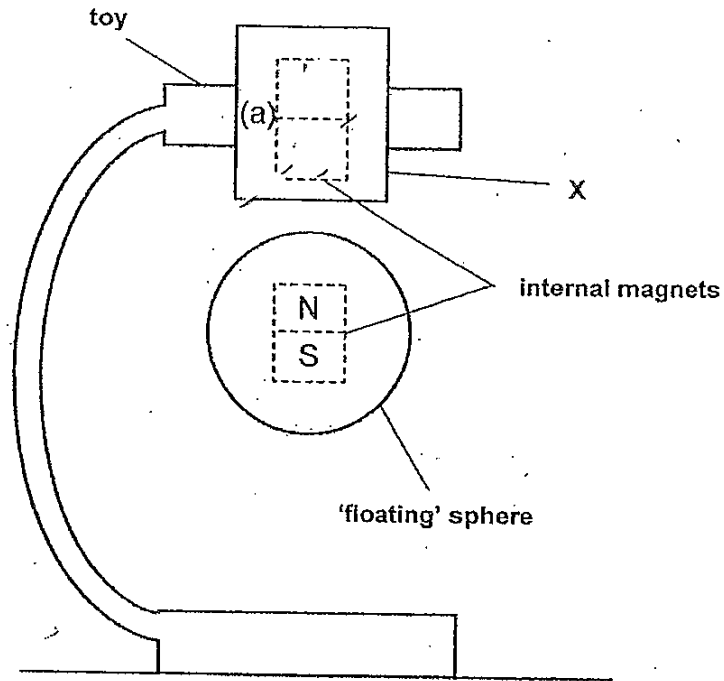

- (a) Label the poles of the magnet in the toy so that the sphere is able to 'float' in the air. [1]
- (b) It is observed that when the toy is removed, the sphere drops to the ground. Explain why. [2]
- 
- (c) Can part X of the toy holding the magnet be made of steel? Explain why. [1]
- 

(Go to the next page)

|       |   |
|-------|---|
| Score | 4 |
|-------|---|

- 36 Samuel set up a circuit tester as shown below to test the electrical conductivity of four materials, W, X, Y and Z.

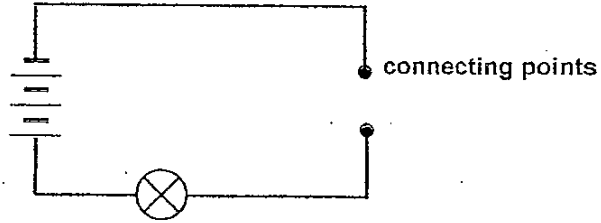

He used each material one at a time across the connecting points and recorded his observation in the table below.

| Material               | W   | X  | Y  | Z   |
|------------------------|-----|----|----|-----|
| Did the bulb light up? | Yes | No | No | Yes |

- (a) Complete the classification chart below using data from the table above. Write suitable sub-headings and the letters (W, X, Y and Z) in the boxes provided. [1]

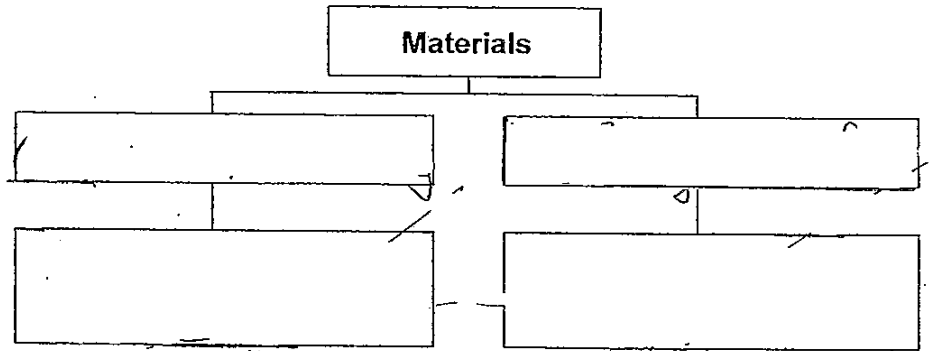

- (b) Samuel next set up the circuit shown below. He wanted to include a switch which could allow him to switch on or off one bulb.

Mark with an "X" on the circuit diagram below to show where he should place the switch. [1]

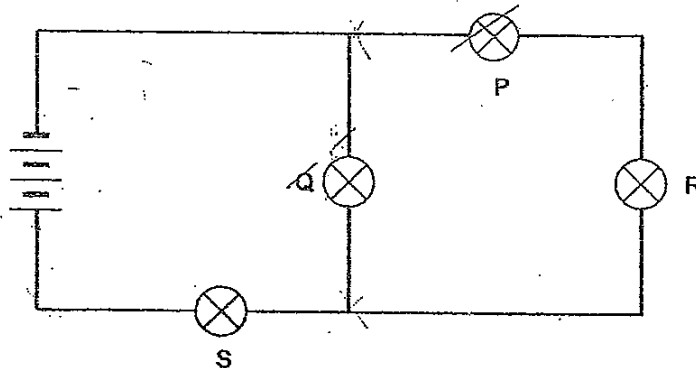

(Go to the next page)

|       |   |
|-------|---|
| Score | 2 |
|-------|---|

- (c) Using only batteries, wires and a switch, Samuel set up three different heating devices as shown below. He wanted to find out which set-up would take the shortest time to heat up 50ml of water to 30°C.

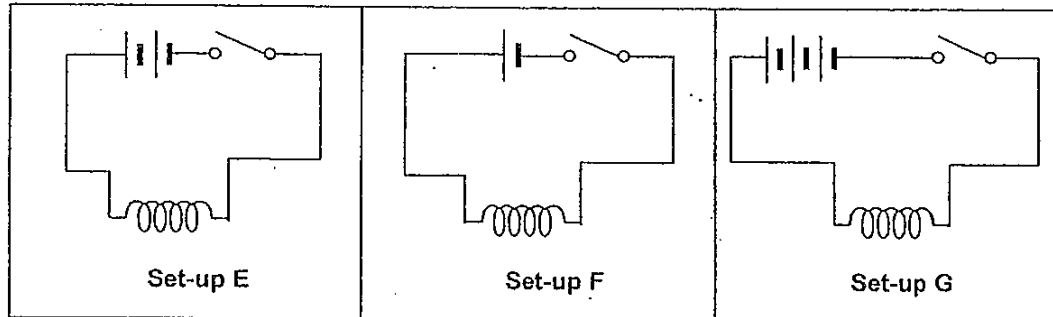
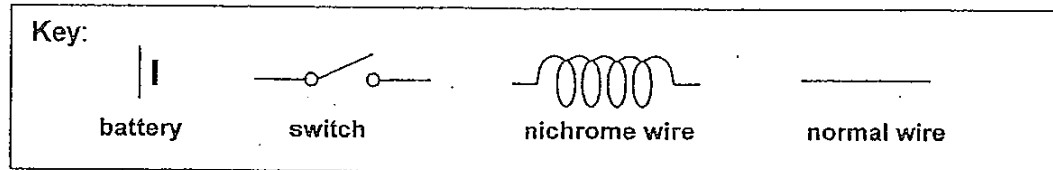

Match the line graphs to the correct set-ups. Write the letters (E, F and G) in the boxes provided. [1]

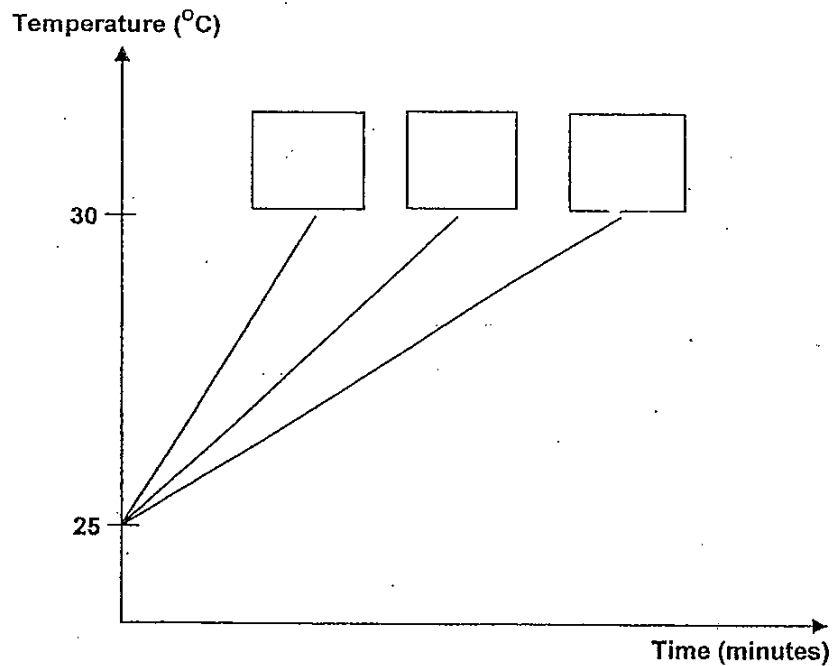

(Go to the next page)

|       |   |
|-------|---|
| Score | 1 |
|-------|---|



37 Sean and Joel set up the experiment shown below.

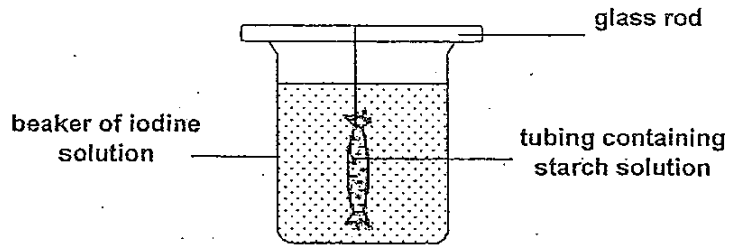

The diagrams below show how the tubing of starch solution had changed after the experiment.

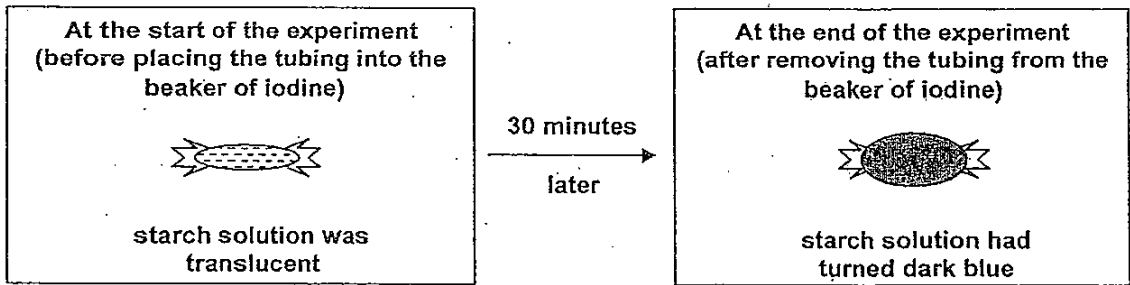

Sean did not find any holes on the tubing. The beaker of iodine solution also did not turn dark blue at the end of the experiment. He was puzzled by his observation. Joel hinted that the tubing resembled a part of a cell.

(a) Which part of the cell does the tubing resemble? [1]

---

(b) Explain your answer in (a). [1]

---

---

---

(Go to the next page)

|       |   |
|-------|---|
| Score | 2 |
|-------|---|

- (c) The boys then examined some freshly plucked leaves under a microscope. The diagrams below show the changes that occur in a leaf seen under a microscope.

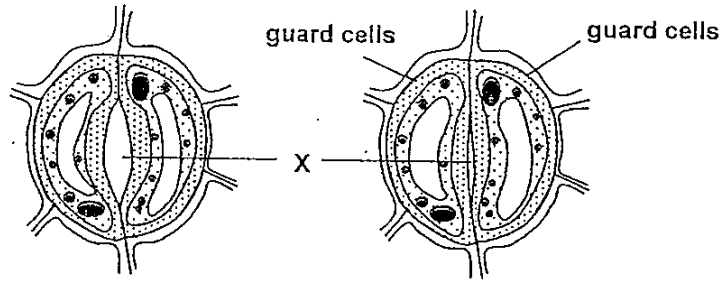

X is an opening found between the two guard cells and its size is affected by these two cells. When the plant is placed under strong light, it is observed that the size of X increases. Explain why X becomes larger. [1]

- 38 Study the food chain shown below.

The graph below shows what happens when the population of organism S increases. Identify the correct graphs for the respective organisms by writing the letters P, Q, R and S beside the line graphs in the boxes provided. [2]

Number of organisms

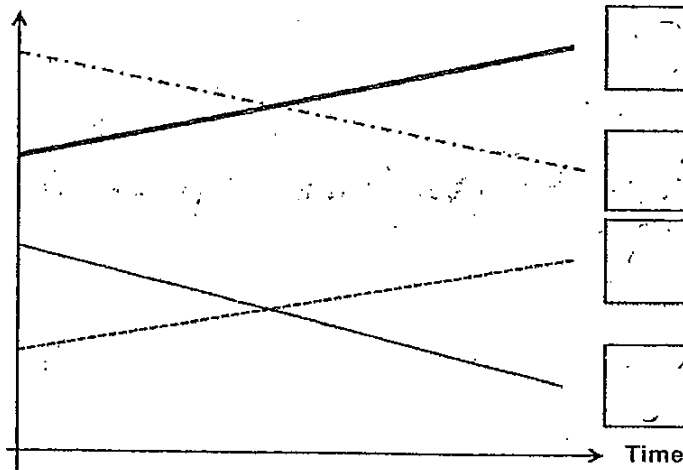

(Go to the next page)

|       |   |
|-------|---|
| Score | 3 |
|-------|---|

Joseph and Benedict think that meat is easier to digest than cheese. They conducted the experiment shown below to test their hypothesis.

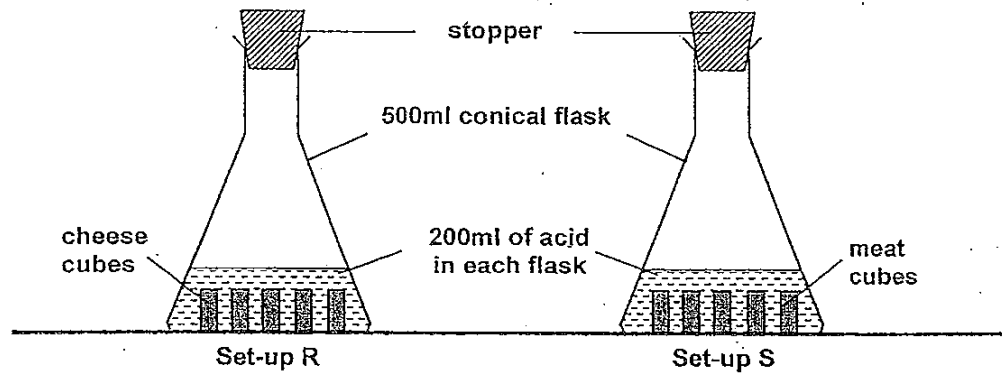

Their experiment was left undisturbed in the laboratory for three days. At the end of the 3<sup>rd</sup> day, Joseph removed the mixture from their respective flasks and measured the volume of each type of remaining food.

- (a) The boys concluded that meat is easier to digest than cheese. What would they have observed in their experiment in order to arrive at this conclusion? [1]

---



---

- (b) Benedict reminded Joseph that it was important to keep the size of the cubes of meat and cheese the same before the experiment started. How would this help to ensure that the test is fair? [1]

---



---



---

(Go to the next page)

|       |   |
|-------|---|
| Score | 2 |
|-------|---|

40

Jeremy wanted to find out if leaves can give out water in the form of water vapour. He prepared Set-up Y as shown below near a window.

- (a) Using only the apparatus provided, draw a labelled diagram to show how his control (Set-up Z) should look like in the space provided. You need not use all the apparatus. [2]

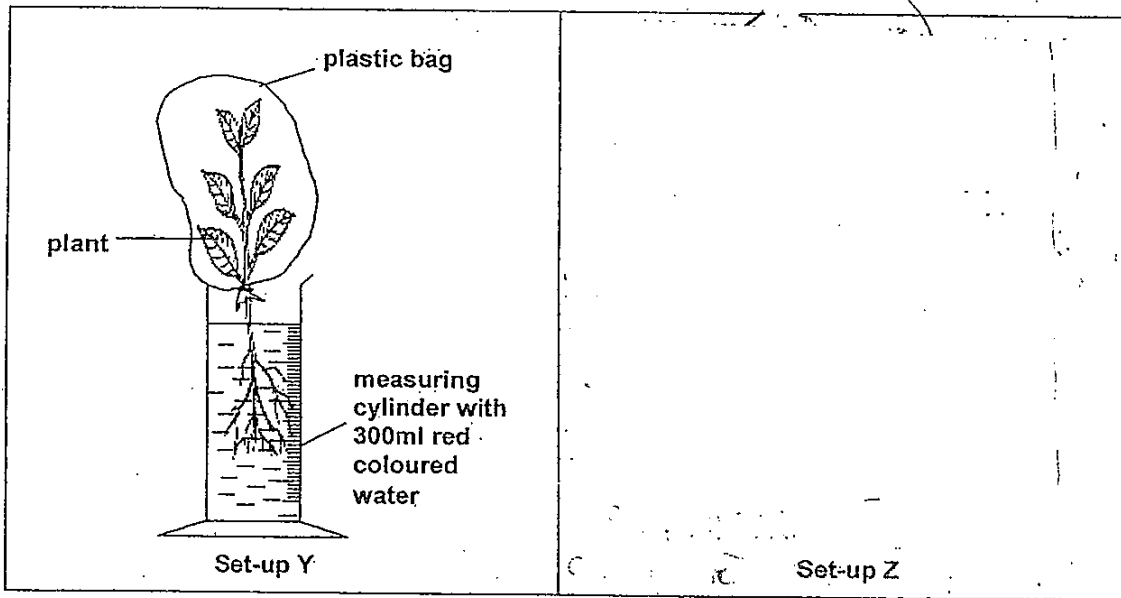
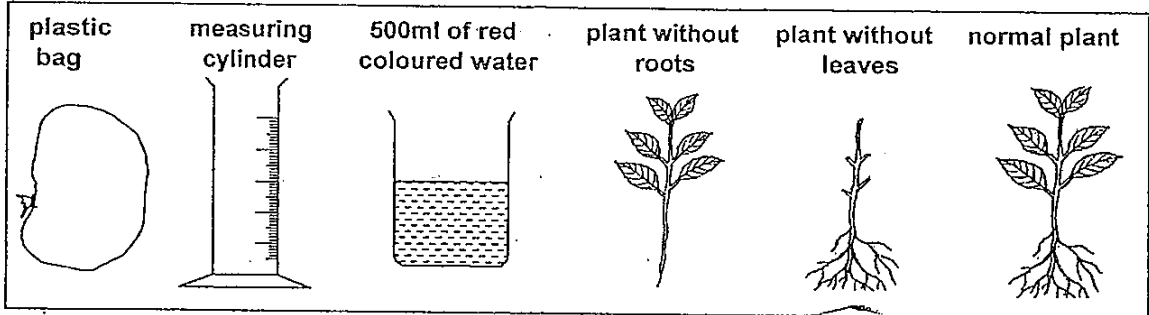

Jeremy noticed droplets of water on the inner surface of the plastic bag in Set-up Y a few hours later. As such, he concluded that leaves can give out water in the form of water vapour. Looking at Jeremy's experiment, his classmate, Rayner, commented that it was also important to add a layer of oil to prevent the water from evaporating. This would then allow Jeremy to conclude that plants can transpire.

- (b) Was Rayner's suggestion for the change necessary for the conclusion to be made? Explain your answer. [1]

\_\_\_\_\_

\_\_\_\_\_

(Go to the next page)

|       |   |
|-------|---|
| Score | 3 |
|-------|---|

41 The picture below shows two fruits, grapes and mango.

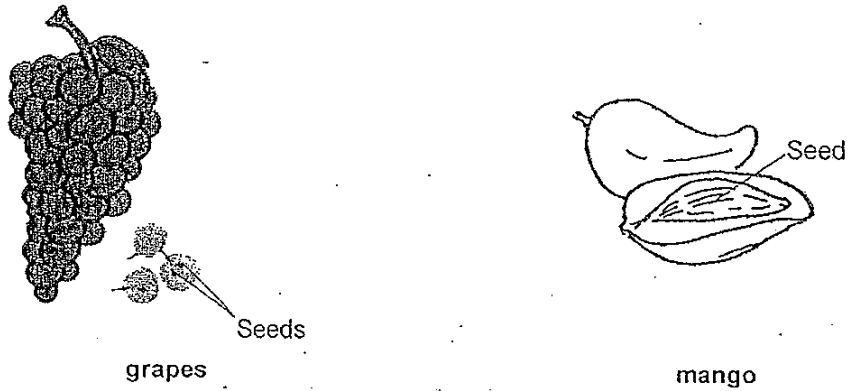

- (a) State the difference between the grapes and the mango in terms of their method of seed dispersal. [1]

---

---

- (b) Grapes have a higher chance of reproducing. Explain why. [1]

---

---

(Go to the next page)

|       |   |
|-------|---|
| Score | 2 |
|-------|---|

- 42 The diagram below shows two beakers each containing 200ml of water and placed in a room with a temperature of 25°C.

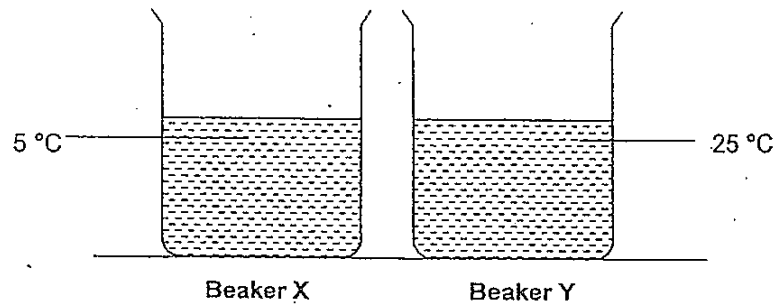

Daniel poured 50ml of water from one of the above beakers to the other. He measured the temperature of the water in both beakers and recorded his readings in the table below.

| Time (minutes) | Temperature of water (°C) |          |
|----------------|---------------------------|----------|
|                | Beaker X                  | Beaker Y |
| 0              | 5                         | 25       |
| 5              | 8                         | 25       |
| 10             | 11                        | 21       |
| 15             | 14                        | 22       |
| 20             | 18                        | 23       |
| 25             | 22                        | 24       |
| 30             | 25                        | 25       |
| 60             | 25                        | ?        |

- (a) Which beaker did Daniel pour the 50ml of water into? [½]
- 
- (b) What would be the most likely temperature of the water in Beaker Y at the 60<sup>th</sup> minute? [½]
- 
- (c) Based on the table, explain the change in temperature for the water in Beaker X for the duration of the experiment. [1]

(Go to the next page)

|       |   |
|-------|---|
| Score | 2 |
|-------|---|

Daniel

- (d) Suggest a way which ~~Joel~~ can cool the water in Beaker Y rapidly without removing it from the table? [1]

---

---

43 The classification table groups some animals according to their body coverings.

| Body coverings of animals |                  |            |          |
|---------------------------|------------------|------------|----------|
| Hair/Fur                  | Shells           | Z          | Scales   |
| rabbit                    | <del>crab</del>  | ostrich    | goldfish |
| <del>monkey</del>         | <del>prawn</del> | kingfisher | cobra    |

- (a) What is the sub-heading that represents Z? [1]

---

- (b) Under which sub-heading would you place a dolphin? [1]

---

- (c) In the table below, classify the animals based on another characteristic such that 3 animals are in one group and the rest are in another group. Give suitable headings for each group. [1]

| Animals |  |
|---------|--|
|         |  |
|         |  |
|         |  |
|         |  |
|         |  |
|         |  |
|         |  |
|         |  |

(Go to the next page)

|       |   |
|-------|---|
| Score | 4 |
|-------|---|

- 44 Roy wanted to find out how the height of the ramp affects the time taken for the toy car to reach the end point of the ramp. He set up the experiment as shown below.

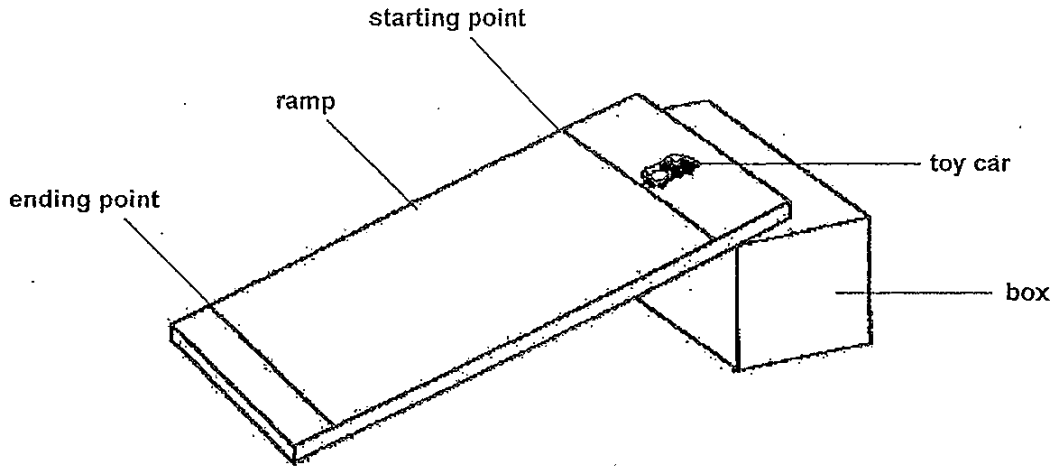

- (a) Tick (✓) the variables that must remain unchanged in the experiment. [1]

| Variables that remain unchanged | Tick (✓) |
|---------------------------------|----------|
| Surface of the ramp             |          |
| Mass of the toy car             |          |
| Height of the box               | ✓        |
| Distanced travelled by the car  | ✓        |

- (b) Roy observed that the higher the ramp was raised, the faster the toy car moved. Explain his observation. [1]

---



---



---

**END OF PAPER**

|       |   |
|-------|---|
| Score | 2 |
|-------|---|





# ExamSutra 考试圣经

## Answer Sheets

### ACS Pri 6 SA2/2010 SCIENCE

|     |   |     |   |     |   |
|-----|---|-----|---|-----|---|
| 1.  | 1 | 11. | 3 | 21. | 3 |
| 2.  | 1 | 12. | 2 | 22. | 4 |
| 3.  | 2 | 13. | 3 | 23. | 2 |
| 4.  | 1 | 14. | 1 | 24. | 2 |
| 5.  | 2 | 15. | 4 | 25. | 3 |
| 6.  | 3 | 16. | 2 | 26. | 2 |
| 7.  | 1 | 17. | 2 | 27. | 2 |
| 8.  | 1 | 18. | 4 | 28. | 2 |
| 9.  | 4 | 19. | 4 | 29. | 2 |
| 10. | 3 | 20. | 3 | 30. | 4 |

- 31.a) Pure water was collected in the cup.  
 31.b) Evaporation and condensation.  
 31.c) The metal sheet became warm as the hot water vapour rising from the beaker.  
 32.a) They are dispersed by wind.  
 32.b) They are light and small.  
 32.c) One is dispersed by water while the other is dispersed by animal.  
 33.a)

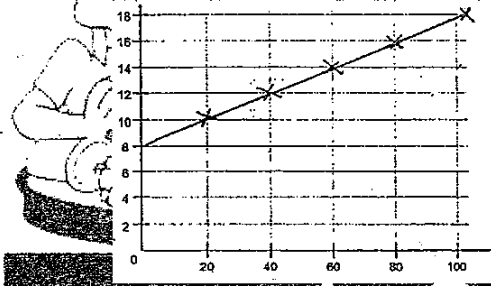

examsutra@yahoo.com.sg

33.b) length of spring/cm

34.a)

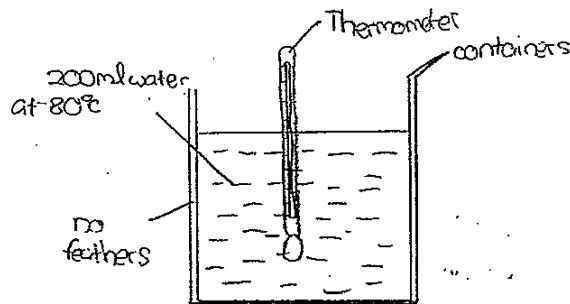

34.b) They also have strong muscles in their wings to help them fly through strong winds.

35.a)

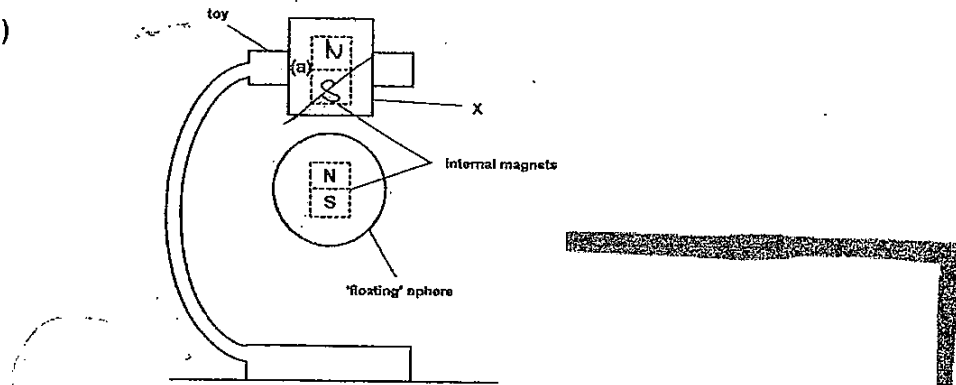

35.b) There is no attractive force to hold the magnet in the air and gravity would pull the sphere to the ground.

35.c) No magnetism will be able to pass through the steel.

36.a)

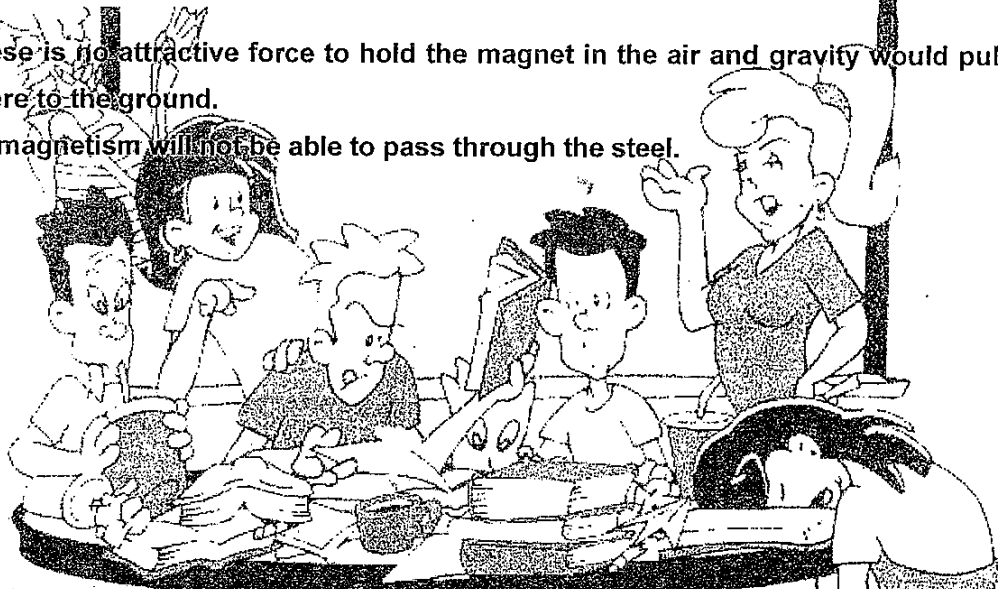

36.b)

[examsutra@yahoo.com.sg](mailto:examsutra@yahoo.com.sg)

36.c)

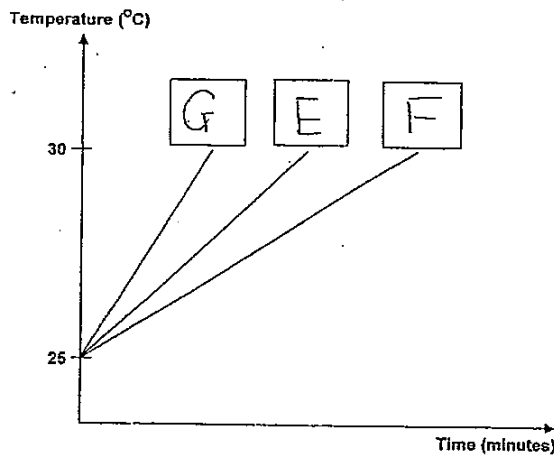

42.a) Beaker Y

42.b) It would be  $25^{\circ}$

42.c) Heat was gained from the surrounding until it became similar to the room temperature.

42.d) By pouring cold water into the beaker

43.a) Feathers

43.b) Under hair/Fur

43.c) Live on Land

Rabbit

Monkey

Ostrich

Kingfisher

Cobra

Live in ocean

Gold fish

Crab

Prawn

44.a) surface of the ramp / mass of the toy car and Distance travelled by the car

44.b) The higher it is raised, the more potential energy the car possesses. Thus there is greater kinetic energy and hence the car travelled a greater distance.

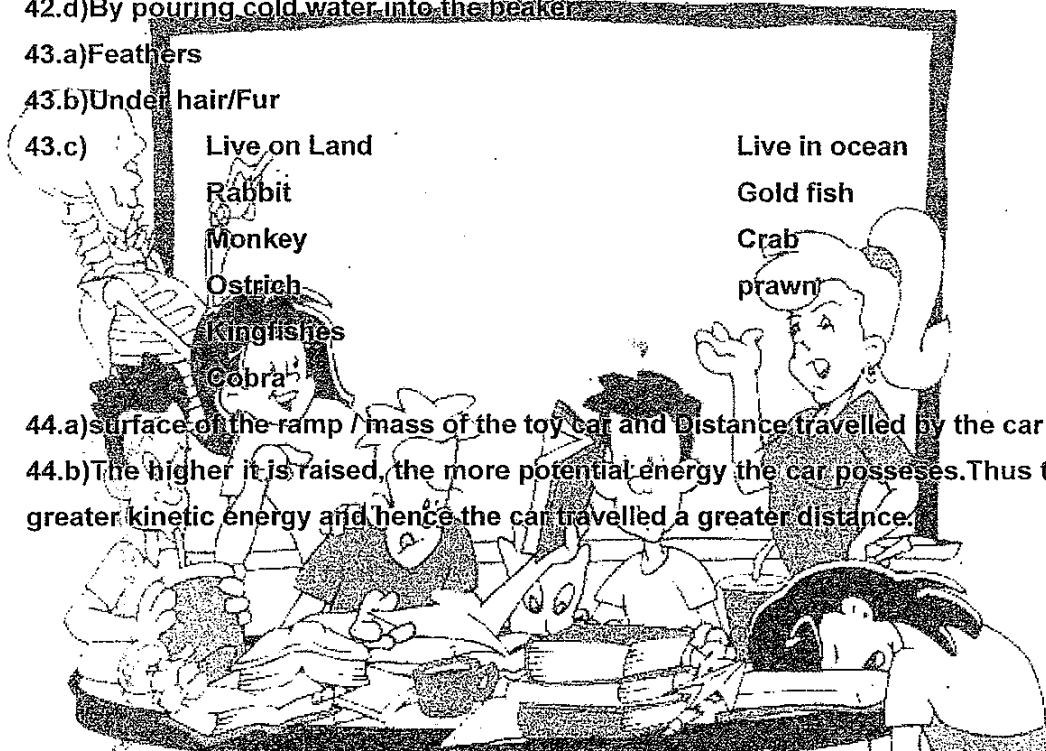

[examsutra@yahoo.com.sg](mailto:examsutra@yahoo.com.sg)

37.a) cell membrane

37.b) It allows iodine to pass through but not the starch solution.

37.c) X is used to allow gaseous exchange to take place between the plant and the surrounding and it also releases excess water.

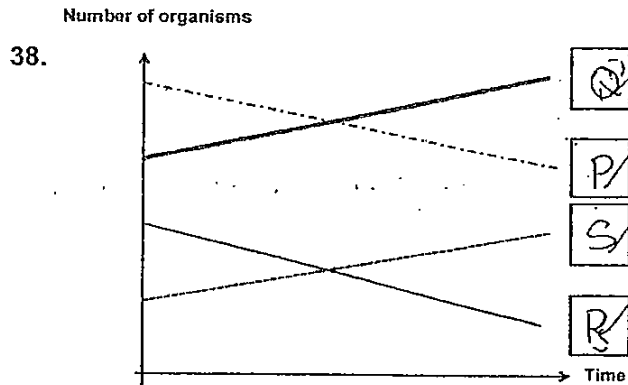

39.a) The amount of the meat cubes would be less than the numbers of cheese cubes.

39.b) The result of the experiment is only due to different types of food.

40.a)

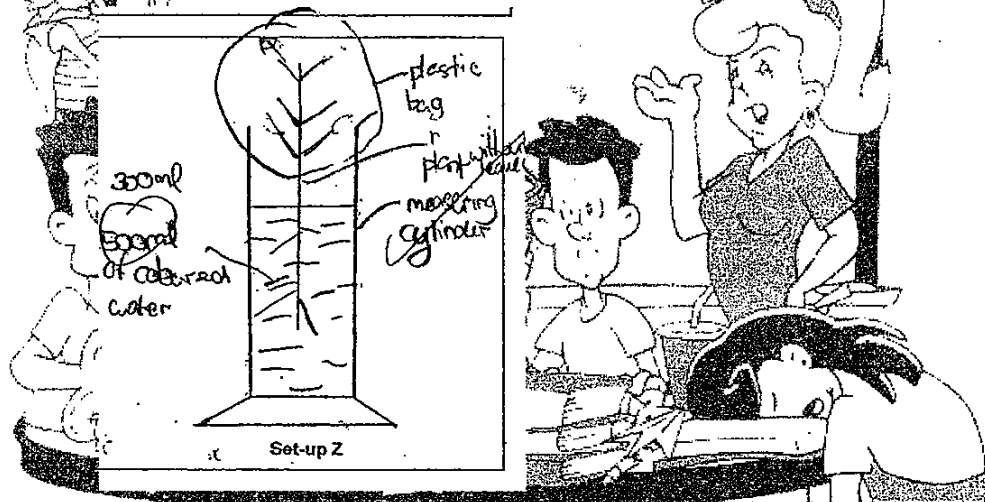

40.b) No. The body of the water would have evaporated by a similar amount in both set-ups.

41.a) The grape seeds are swallowed and passed out of the animal while the mango seed is being thrown away.

41.b) It has more seeds than a mango.

examsutra@yahoo.com.sg