



RED SWASTIKA SCHOOL

RED SWASTIKA SCHOOL

2011 CONTINUAL ASSESSMENT 1

MATHEMATICS PAPER 1

Name : _____ ()

Class : Primary 6 / _____

Date : 24 February 2011

BOOKLET A

15 Questions

20 Marks

Duration of Paper 1 (Booklets A & B): 50 minutes

Note:

1. Do not open this Booklet until you are told to do so.
2. Read carefully the instructions given at the beginning of each part of the Booklet.
3. Do not waste time. If a question is difficult for you, go on to the next one.
4. Check your answers thoroughly and make sure you attempt every question.
5. In this booklet, you should have the following:
 - (a) Page 1 to Page 5
 - (b) Questions 1 to 15
6. You are not allowed to use a calculator.

Questions 1 to 10 carry 1 mark each. Questions 11 to 15 carry 2 marks each. For each question, four options are given. One of them is the correct answer. Make your choice (1, 2, 3 or 4). Shade the correct oval (1, 2, 3 or 4) on the Optical Answer Sheet. (20 marks)

1 Simplify $p + 7 + 4p - 3$.

- (1) $3p - 4$
- (2) $3p + 10$
- (3) $5p + 4$
- (4) $5p - 10$

2 In the figure below, ABCD is a parallelogram. Which one of the following statements about the parallelogram is correct?

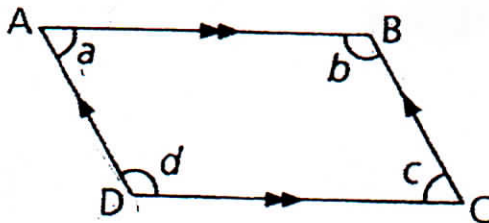

- (1) $\angle d = \angle c$
- (2) $AB \parallel DA$
- (3) $\angle a = \angle c = 180^\circ$
- (4) $\angle a + \angle d = 180^\circ$

3 In the figure below, ABCD is a rhombus. Find $\angle x$.

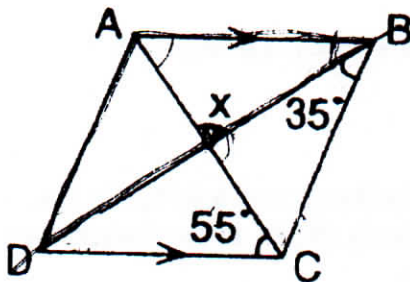

- (1) 35°
- (2) 45°
- (3) 55°
- (4) 90°

4 Mr Tan paid for 6 oranges that cost \$a each with a \$10-note. How much change would he receive?

- (1) $\$(10 - a)$
- (2) $\$(10 - 6a)$
- (3) $(100 - 60a)\text{¢}$
- (4) $(10 - 600a)\text{¢}$

5 Mr Ng spent $\frac{1}{4}$ of his money on transport and $\frac{2}{3}$ of the remainder on food. What fraction of his money was left?

- (1) $\frac{1}{2}$
- (2) $\frac{1}{3}$
- (3) $\frac{1}{4}$
- (4) $\frac{3}{4}$

6 In the figure below, PQRS is a square and QRT is an equilateral triangle. Find $\angle QPT$.

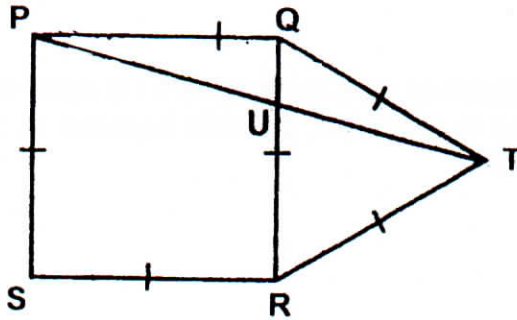

- (1) 15°
- (2) 60°
- (3) 90°
- (4) 105°

- 7 What fraction of the figure is not shaded?

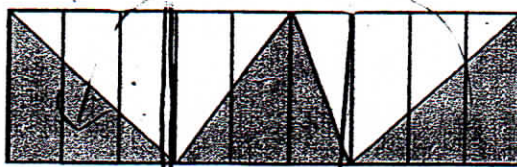

- (1) $\frac{1}{2}$
(2) $\frac{1}{3}$
(3) $\frac{2}{5}$
(4) $\frac{9}{20}$
- 8 $\frac{1}{9}$ of Ken's savings is equal to $\frac{2}{7}$ of Ron's savings. What is the ratio of Ron's savings to Ken's savings?
- (1) 1 : 2
(2) 7 : 9
(3) 9 : 7
(4) 7 : 18
- 9 James and Ali collected pictures of cars in the ratio 5 : 6. After James gave away 90 of his pictures to his sister, the ratio became 1 : 2. How many pictures did Ali collect?
- (1) 45
(2) 180
(3) 225
(4) 270
- 10 Amy, Beth and Claire shared some stamps in the ratio 6 : 2 : 5. Beth had 24 stamps fewer than Claire. Amy gave $\frac{1}{3}$ of her stamps to Beth, how many more stamps did Claire have than Beth in the end?
- (1) 8
(2) 32
(3) 40
(4) 72

- 11 The figure below consists of two squares of sides 10 m and 20 m. Find the total area of the shaded parts.

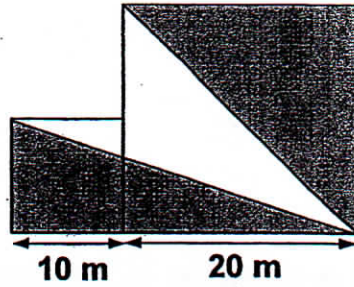

- (1) 50 m^2
 (2) 150 m^2
 (3) 350 m^2
 (4) 500 m^2
- 12 The total number of legs of chickens and cows in a farm is n . If there are 12 more chickens than cows in the farm, find the number of cows in the farm in terms of n .

- (1) $\frac{n - 24}{2}$
 (2) $\frac{n - 24}{6}$
 (3) $\frac{n - 24}{2} - 12$
 (4) $\frac{n - 24}{6} - 12$

- 13 PQRS is a rectangle. RTU and OPT are isosceles triangles. $SR \parallel TU$. Find $\angle SPT$.

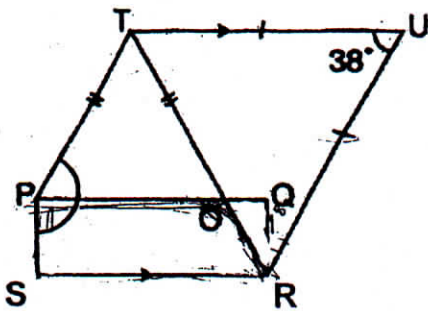

- (1) 71°
 (2) 109°
 (3) 128°
 (4) 161°

14 Andy is $1\frac{1}{2}$ times as tall as Ben. Ben is $\frac{1}{4}$ the total height of Andy and Carl. The total height of the 3 boys is 480 cm. How tall is Ben?

- (1) 96 cm
- (2) 120 cm
- (3) 160 cm
- (4) 200 cm

15 The ratio of the length of a rectangle to the breadth is 3 : 2. The perimeter of the rectangle is 150 m. What is the area of the rectangle?

- (1) 1 350 m²
- (2) 1 500 m²
- (3) 3 375 m²
- (4) 5 400 m²



RED SWASTIKA SCHOOL

RED SWASTIKA SCHOOL

2011 CONTINUAL ASSESSMENT 1

MATHEMATICS PAPER 1

Name : _____ ()

Class : Primary 6 / _____

Date : 24 February 2011

BOOKLET B

15 Questions
20 Marks

In this booklet, you should have the following:

- (a) Page 6 to Page 10
- (b) Questions 16 to 30

MARKS

	OBTAINED	POSSIBLE
BOOKLET A		20
BOOKLET B		20
TOTAL		40

Parent's Signature : _____

Questions 16 to 25 carry 1 mark each. Write your answers in the spaces provided. For questions which require units, give your answers in the units stated.

(10 marks)

-
- 16 Use the digits, 5, 7, 1, 8, to form the smallest possible odd number that is divisible by 3.

Ans: _____

- 17 Express 12% as a fraction in its simplest form.

Ans: _____

- 18 Find the sum of 30 tens, 15 ones, 6 tenths and 2 hundredths.

Ans: _____

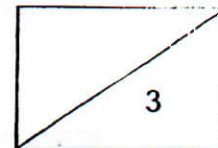

- 19 $87 \times 31 + 53 \times 31 = \underline{\hspace{2cm}} \times 31 - 62$
What is the missing number?

Ans: _____

- 20 Find the value of $98 - (32 - 6 \times 4) + 14 \div 2$.

Ans: _____

- 21 How many sixths are there in $4\frac{2}{3}$?

Ans: _____

- 22 If $a = 4$, find the value of $\frac{176 - 6a}{2a}$.

Ans: _____

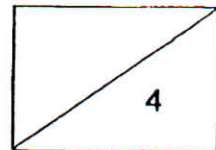

- 23 In the figure below, what is the value of x ?

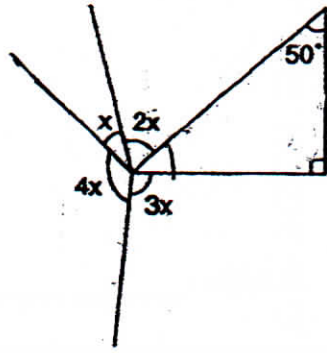

Ans: _____°

- 24 James is m years old. Ken is 3 years older than James. What will their total age be in 4 years time?

Ans: _____

- 25 In the figure below not drawn to scale, $\frac{2}{11}$ of X overlaps with $\frac{1}{4}$ of Y . Express the ratio of the unshaded area of X to the unshaded area of Y in its simplest form.

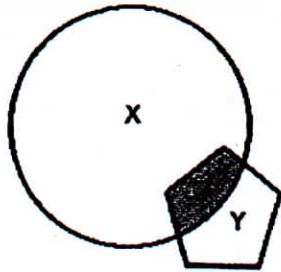

Ans: _____

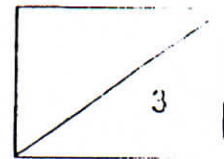

Questions 26 to 30 carry 2 marks each. Show your workings clearly in the space provided for each question and write your answers in the spaces provided. For questions which require units, give your answers in the units stated.

(10 marks)

- 26 Mrs Tan had $\$200x$. She gave $\$4x$ to her daughter and the remainder of the money was shared equally among her four sons. How much did each of her sons receive in terms of x ?

Ans: \$ _____

- 27 In the figure below not drawn to scale, ABCD is a parallelogram. Find $\angle ADG$.

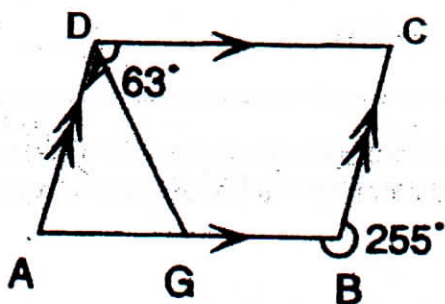

Ans: _____ °

- 28 Beth spent some of her money on a book and $\frac{1}{8}$ of the remainder plus $\$12$ on a dress. She was left with $\$44$. How much did she spend on her dress?

Ans: \$ _____

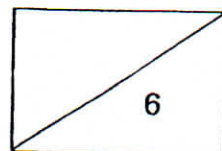

132

- 29 The ratio of the number of boys to the number of girls in a school is 5 : 4. The ratio of the number of pupils to the number of teachers is 36 : 3. If there are 600 boys, how many teachers are there?

Ans: _____

-
- 30 The ratio of the number of boys to the number of girls in the Art Club was 5 : 3. After 6 boys resigned, there were 12 more boys than girls. How many boys were there at first?

Ans: _____

END OF PAPER

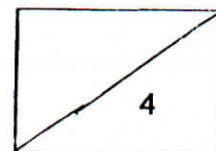



RED SWASTIKA SCHOOL

RED SWASTIKA SCHOOL

2011 CONTINUAL ASSESSMENT 1

MATHEMATICS PAPER 2

Name : _____ ()

Class : Primary 6 / _____

Date : 24 February 2011

18 Questions

60 Marks

Duration of Paper 2: 1 hour 40 minutes

Note:

1. Do not open this Booklet until you are told to do so.
2. Read carefully the instructions given at the beginning of each part of the Booklet.
3. Do not waste time. If a question is difficult for you, go on to the next one.
4. Check your answers thoroughly and make sure you attempt every question.
5. In this paper, you should have the following:
 - (a) Page 1 to Page 13
 - (b) Questions 1 to 18
6. You are allowed to use a calculator.

MARKS

	OBTAINED	POSSIBLE
PAPER 1		40
PAPER 2		60
TOTAL		100

Parent's Signature : _____

Questions 1 to 5 carry 2 marks each. Show your workings clearly in the space below each question and write your answers in the spaces provided. For questions which require units, give your answers in the units stated.

(10 marks)

- 1 Ryan had $\$(50 + 8x)$. Sam had $\$9x$ more than Ryan. Ryan was given another $\$x$ and Sam was given twice as much the amount given to Ryan. How much do they have now altogether? Give your answer in terms of x .

Ans: \$ _____

- 2 In the figure below, find the sum of the marked angles.

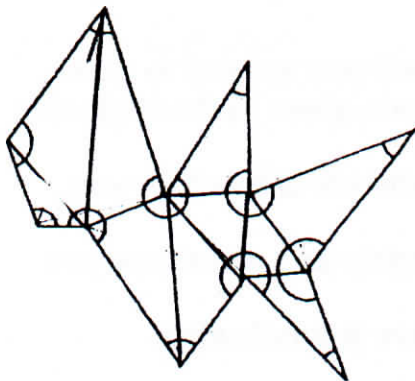

Ans: _____ °

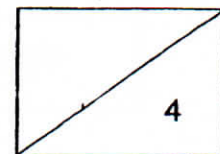

- 3 The ratio of the number of golf balls in Box A to the number of golf balls in Box B was 5 : 4. 10 golf balls were taken out from Box A and placed into Box B. The two boxes then had the same number of golf balls. How many golf balls were there in Box A at first?

Ans: _____

- 4 When a bottle was $\frac{1}{8}$ full, it had a mass of 300g. When it was $\frac{1}{4}$ full, it had a mass of 400g. What was its mass when it was $\frac{3}{4}$ full?

Ans: _____ g

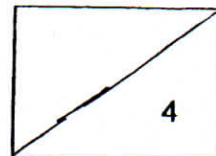

5 Find the area of the shaded figure.

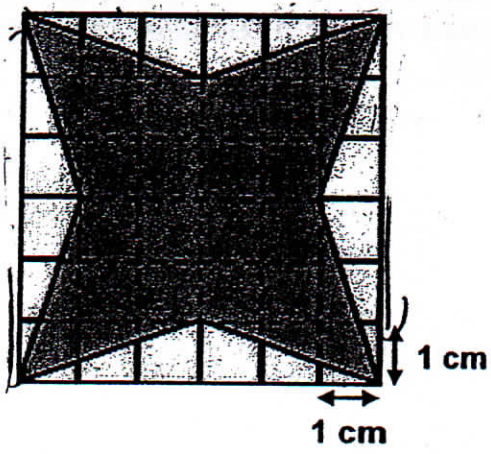

Ans: _____ cm²

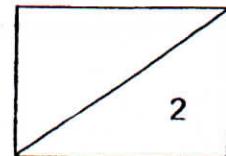

For Questions 6 to 18, show your workings clearly in the space below each question and write your answers in the spaces provided:

The number of marks available is shown in brackets [] at the end of each question or part-question. (50 marks)

- 6 Draw a rhombus ABCD in which $AB = 5 \text{ cm}$ and $\angle ABC = 50^\circ$. [2]
Measure the length of BD. [1]

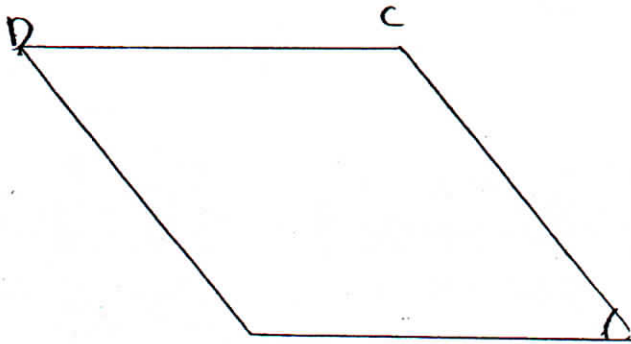

Ans: $BD =$ _____ [1]

- 7 In the figure below, not drawn to scale, a rectangular piece of paper is folded as shown. Find $\angle x$.

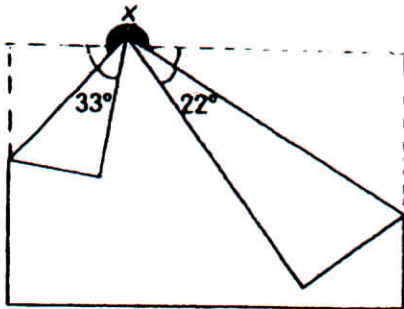

Ans: _____ [3]

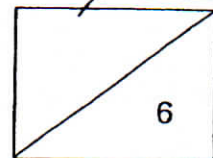

- 8 $\frac{2}{9}$ of Rani's balloons were red and the rest were green. She gave away 15 green balloons and bought another 25 red balloons. She then had the same number of red and green balloons. How many green balloons did she have at first?

Ans: _____ [3]

- 9 In the figure below, not drawn to scale, ABCD is a square. The area of the square is 100 m^2 . $AX = YD$. The ratio of AX to XY is 1 : 2. What is the area of WXYZ?

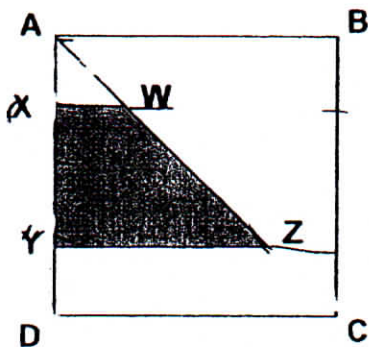

Ans: _____ [3]

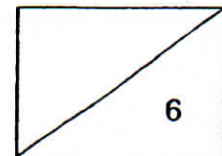

- 10 Mrs Lee and Mrs Tan went shopping. Mrs Lee spent $\frac{3}{8}$ of her money and had \$120 left. Mrs Tan had $\frac{1}{3}$ of her money left after spending twice as much as Mrs Lee. What was the total amount of money the women had before they went shopping?

Ans: _____ [3]

- 11 A cup of coffee cost \$5 and a cup of tea cost 20% less. Mr Lim collected \$925 from the sale of these two types of beverages. If 37.5% of the number of cups sold were tea, how many cups of coffee did Mr Lim sell?

Ans: _____ [3]

6

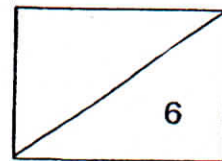

14°

- 12 The figure below, not drawn to scale, is made up of triangles and 3 identical squares. Find $\angle x$.

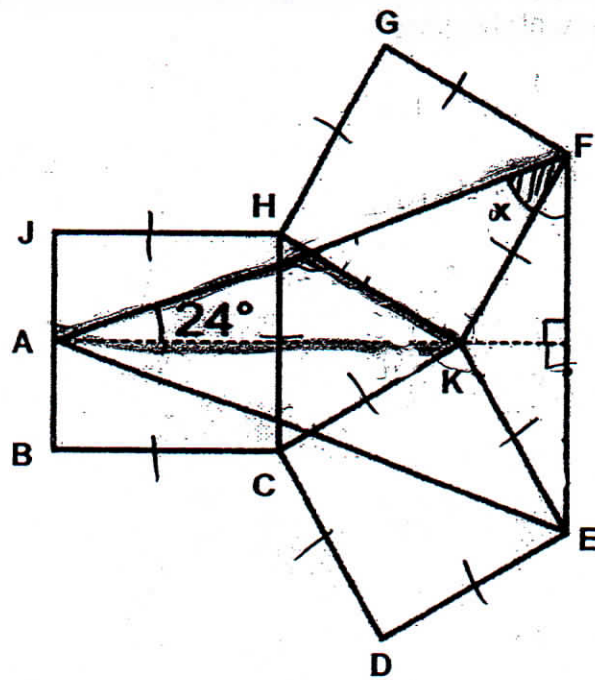

Ans: _____ [4]

7

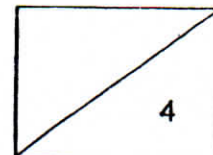

[4]

- 13 Five similar rectangles are used to form a big rectangle RSTU. If the area of RSTU is 240 cm^2 , what is its perimeter?

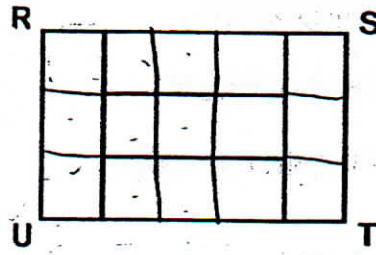

Ans: _____ [4]

8

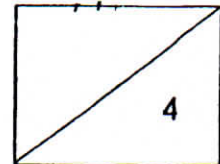

142

14 Tank B had 42 l more water than Tank A. When 9 l of water was added to each of the 2 tanks, the volume of water in Tank B became 4 times the volume of water in Tank A. The base area of Tank A was 1000 cm^2 and Tank B measured 94 cm by 40 cm.

- (a) Find the height of water in Tank A in the end.
- (b) What was the height of water in Tank B at first?

Ans: (a) _____ [2]

(b) _____ [1]

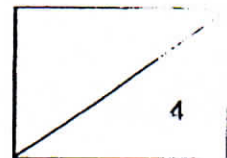

- 15 Ravi had a total of 80 pieces of \$10 notes and \$50 notes. He used $\frac{1}{2}$ of his \$10 notes and withdrew another four pieces of \$50 notes from the bank. After which, the number of \$50 notes he had was $\frac{2}{5}$ the number of \$10 notes. Find the total value of the 80 pieces of notes he had at first.

Ans: _____ [5]

10

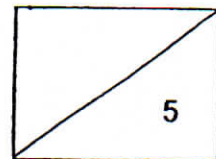

144

16 Joseph has some local and foreign stamps in 2 boxes. In Box A, the number of local and foreign stamps are in the ratio 3 : 4. In Box B, the number of local stamps is twice the number of foreign stamps. Joseph transfers half of the foreign stamps from Box A to Box B. The number of stamps in Box A becomes 105 and the ratio of the number of local stamps to the number of foreign stamps in Box B becomes 6 : 5.

- (a) How many foreign stamps have been transferred from Box A to Box B?
- (b) What is the number of stamps in Box B at first?

Ans: (a) _____ [3]

(b) _____ [2]

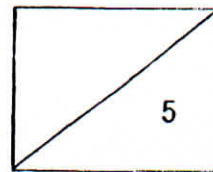

17 Jason spent \$36 on some rulers, pencils and erasers. The ratio of the amount of money he spent on the rulers, pencils and erasers was

3 : 2 : 4. Rulers were sold at 5 for \$2. The number of rulers he bought was $\frac{3}{4}$

the number of pencils. The number of pencils was $\frac{1}{4}$ the number of erasers.

How many more erasers than rulers did he buy?

Ans: _____ [5]



12

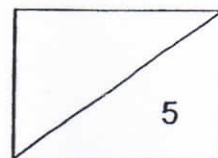

146

- 18 Tim and James had a sum of money each. Tim gave $\frac{1}{6}$ of his share to James. In return, James gave half of what he had to Tim. After that, Tim gave $\frac{1}{5}$ of the amount he had to James. Eventually, both Tim and James had an equal amount of \$2000 each. How much more money did James have than Tim at first?

Ans: _____ [5]

END OF PAPER

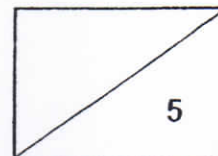



ANSWER SHEET

EXAM PAPER 2011

SCHOOL : RED SWASTIKA
SUBJECT : PRIMARY 6 MATHEMATICS

TERM : CA1

Q1	Q2	Q3	Q4	Q5	Q6	Q7	Q8	Q9	Q10	Q11	Q12	Q13	Q14	Q15
3	4	4	2	3	1	1	4	4	1	3	2	4	1	1

- 16)1587 17)3/25 18)315.62 19)142 20)97
- 21)28 22)19 23)32° 24)(2m+11) 25)3:2
- 26)\$(49x) 27)42° 28)\$20 29)90 teachers 30)45 boys

Paper 2

1)Amt.of money Sam had at first→ $$(50+8x)+$9x = $(50+17x)$
 Amt.of money Ryan had now→ $$(50+8x)+$x = ((50+9x)$
 Amt.of money Sam had now→ $(50+17x)+$x \times 2 = $(50+19x)$
 Total amt.of money they had altogether→ $$(50+9x)+$(50+19x) = $(100+28x)$

2)Sum of the marked angles → $180^\circ \times 10 = 1800^\circ$

3)1 unit→10

10 units→ $10 \times 10 = 100$

There were 100 golf balls in Box A at first.

4)4 units→ $400g - 300g = 100g$

1 unit→ $100g \div 4 = 25g$

4 units→ $25g \times 4 = 100g$

Mass of the empty bottle→ $300g - 100g = 200g$

Mass when is was $\frac{3}{4}$ full→ $(25g \times 24) + 200g = 80g$

5)Area of whole figure→ $6cm \times 6cm = 36cm^2$

Area of triangle A→ $\frac{1}{2} \times 6cm \times 1cm = 3cm^2$

Area of triangles A,B C and D→ $3cm^2 \times 4 = 12cm^2$

Area of the shaded figure→ $36cm^2 - 12cm^2 = 24cm^2$

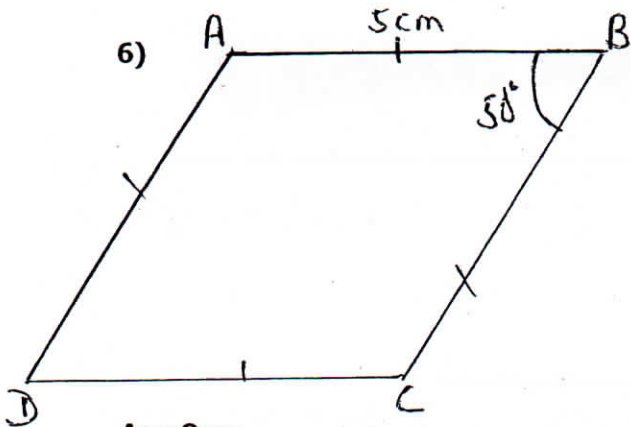

7) $\angle x \rightarrow 33^\circ + 22^\circ + 180^\circ = 235^\circ$

8) 5 units $\rightarrow 25 + 15 = 40$

1 unit $\rightarrow 40 \div 5 = 8$

7 units $\rightarrow 8 \times 7 = 56$

No. of green balloons she had at first $\rightarrow 56$

9) Length of the square $\rightarrow \sqrt{100\text{m}^2} = 10\text{m}$

Length of XY $\rightarrow (10\text{m} \div 4) \times 2 = 5\text{m}$

Area of rectangle shaded $\rightarrow 10\text{m} \times 5\text{m} = 50\text{m}^2$

Area of WXYZ $\rightarrow 50\text{m}^2 \div 2 = 25\text{m}^2$

10) 5 units $\rightarrow \$120$

1 unit $\rightarrow \$120 \div 5 = \24

Total amount of money the women had before they went shopping

$\rightarrow \$24 \times 17 = \408

11) 20% = $\frac{1}{5}$

37.5% = $\frac{3}{8}$

Cost of a cup of tea $\rightarrow \frac{4}{5} \times \$5 = \$4$

1 group TTTCCCC

Cost of 1 group $\rightarrow (3 \times \$4) + (5 \times \$5) = \$12 + \$25 = \$37$

No. of groups $\rightarrow \$925 / \$37 = 25$

No. of cups of coffee he sold $\rightarrow 25 \times 5 = 125$ cups of coffee.

12) $\angle HCK = \angle CHK = \angle CKh = 60^\circ$

$\angle FAE \rightarrow 24^\circ \times 2 = 48^\circ$

$\angle AEF + \angle AFE \rightarrow 180^\circ - 48^\circ = 132^\circ$

$\angle FKE \rightarrow 360^\circ - 60^\circ - 90^\circ - 90^\circ = 120^\circ$

$\angle KFE \rightarrow (180^\circ - 120^\circ) \div 2 = 30^\circ$

$\angle AFE \rightarrow 180^\circ - 24^\circ - 90^\circ = 66^\circ$

$\angle X \rightarrow 66^\circ - 30^\circ = 36^\circ$

13) Area of 1 small rectangle $\rightarrow 240 \div 5 = 48\text{cm}^2$
The ratio of the length of each small rectangle is
48 $\rightarrow 1 \times 48$
 $\rightarrow 2 \times 24$
 $\rightarrow 3 \times 16$
 $\rightarrow 4 \times 12$
Length of RS $\rightarrow 5 \times 4 = 20\text{cm}$
Length of RU $\rightarrow 3 \times 4 = 12\text{cm}$
Perimeter of RSTU $\rightarrow (20+12) \times 2 = 64\text{cm}$

14) a) 3 units $\rightarrow 42\text{L}$
1 unit $\rightarrow 42\text{L} \div 3 = 14\text{L}$
Height of the water in Tank A in the end $\rightarrow 14000/1000 = 14\text{cm}$
b) Volume of water in tank B at first $\rightarrow (14 \times 4) - 9 = 47\text{L} = 47000\text{cm}^3$
Height of water in Tank B at first $\rightarrow 47000/94 \times 40 = 25/2 = 12.5\text{cm}$

15) 12 units $\rightarrow 80 + 4 = 84$
1 unit $\rightarrow 84 \div 12 = 7$
10 units $\rightarrow 7 \times 10 = 70$
2 unit $\rightarrow 7 \times 2 = 14$
No. of \$10 notes at first $\rightarrow 70$
No. of \$50 notes at first $\rightarrow 14 - 4 = 10$
Total amt. of money at first $\rightarrow (70 \times \$10) + (10 \times \$50) = \$1200$

16) a) 5 units $\rightarrow 105$
1 unit $\rightarrow 105 \div 5 = 21$
2 units $\rightarrow 21 \times 2 = 42$
No. of stamps transferred $\rightarrow 42$
b) 9 units $\rightarrow 21 \times 9 = 189$
No. of stamps in Box B at first $\rightarrow 189$

17) 9 units $\rightarrow \$36$
1 unit $\rightarrow \$36 \div 9 = \4
Amt. of money spent on rulers $\rightarrow \$4 \times 3 = \12
Amt. of money spent on pencils $\rightarrow \$4 \times 2 = \8
Amt. of money spent on erasers $\rightarrow \$4 \times 4 = \16
No. of rulers he bought $\rightarrow (\$12 \div 2) \times 5 = 30$
No. of pencils he bought $\rightarrow (30 \div 3) \times 4 = 40$
No. of erasers he bought $\rightarrow 40 \times 4 = 160$
More erasers than rulers he bought $\rightarrow 160 - 30 = 130$

18) 4 units → \$2000

1 unit → $\$2000 \div 4 = \500

Tim → $\$500 \times 5 = \2500

James → $\$500 \times 3 = \1500

Tim → $\$2500 - \$1500 = \$1000$

James → $\$1500 \times 2 = \3000

5 units → \$1000

1 unit → $\$1000 \div 5 = \200

Tim → $\$1000 + \$200 = \$1200$

James → $\$3000 - \$200 = \$2800$

Amt. of money James had more than Tim at first

→ $\$2800 - \$1200 = \$1600$