

Name: _____ ()

Class: Primary 6 _____

CHIJ ST NICHOLAS GIRLS' SCHOOL

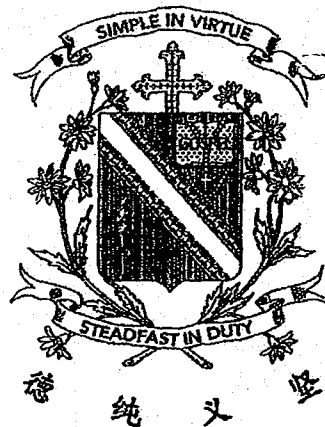

**Primary 6
Preliminary Examination
SCIENCE
BOOKLET A**

22 August 2019

Total Time for Booklet A and B: 1 hour 45 minutes

**28 questions
56 marks**

**Do not open this booklet until you are told to do so.
Follow all instructions carefully.
Answer all questions.**

This booklet consists of 21 printed pages.

Section A (28 x 2 marks = 56 marks)

For each question from 1 to 28, four options are given. One of them is the correct answer. Make your choice (1, 2, 3 or 4) and shade your answer on the Optical Answer Sheet provided.

1. The two graphs below show how the light intensity and the depth of the pond affect the rate of photosynthesis of the submerged water plants.

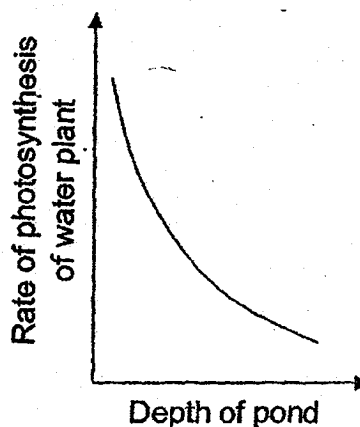
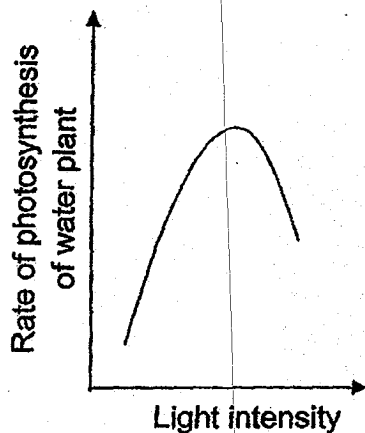

Based on the graphs above, which one of the following statements is correct?

- (1) The light intensity does not affect the rate of photosynthesis.
 - (2) The rate of photosynthesis increases as the light intensity increases.
 - (3) The rate of photosynthesis does not depend on the depth of the pond.
 - (4) The lower the depth of the pond, the higher the rate of photosynthesis.
2. Which one of the following is not a fossil fuel?
- (1) coal
 - (2) charcoal
 - (3) petroleum
 - (4) natural gas

3. The table below shows the stages of development of a fertilized human egg.

Period	Stages
End of 1 st week	Fertilized egg implants itself in the womb
End of 4 th week	Brain, spinal cord and nervous system are formed
End of 8 th week	Face and limbs are visible
Around 12 th week	Foetus starts to move
End of 16 th week	Entire body parts are formed
End of 28 th week	Head and body are proportionate
End of 38 th week	Foetus is ready to be born

From the table above, when is the earliest time the parents are able to find out the gender of their baby?

- (1) After 1st week
 - (2) After 8th week
 - (3) After 16th week
 - (4) After 38th week
4. Reforestation is a process of replanting an area with trees. Which of the following are the benefits of reforestation?
- A More soil would be eroded.
 - B More oxygen would be released into the air.
 - C More carbon dioxide would be released into the air.
 - D More food and shelter would be available for the animals.
- (1) A and B only
 - (2) C and D only
 - (3) B and D only
 - (4) A, B, C and D

5. F, G, H, J and K are five organisms living in a community. The food relationships between the five organisms are stated below:

- Organism K feeds on Organism J.
- Organism F and J feed on Organism H.
- Organism G feeds on Organisms F and H.

Which one of the following is correct?

	Producer(s)	Plant-eater(s)	Animal-eater(s)	Plant-and-animal eater(s)
(1)	G	F	K and J	H
(2)	F	J	G	H and K
(3)	H	J and F	K	G
(4)	G and K	H	F	J

6. The picture below shows the structural adaptations of two plants.

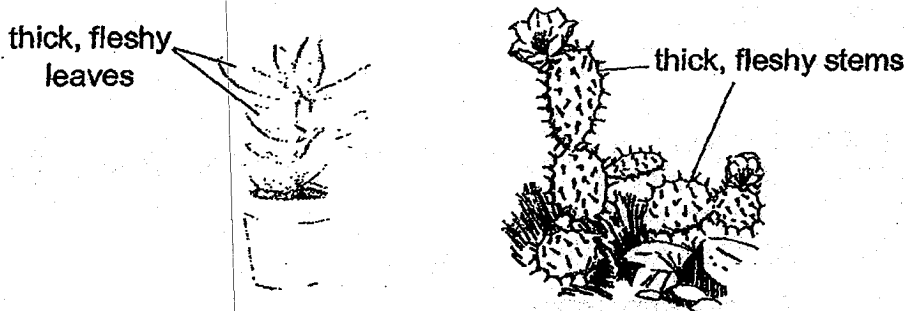

Which one of the following best explains the function of these adaptations?

- (1) Adaptation for pollination.
- (2) Adaptation for reproduction.
- (3) Adaptation for water retention.
- (4) Adaptation for getting sunlight.

7. The table below shows the characteristics of some flowers which attract specific animals.

Animal	The characteristics of flowers that mainly attract the animal		
	Size	Colour	Smell / Odour
moth	small	white	-
beetle	large	white	spicy or foul
bee	small	bright blue or yellow	-
bird	large	red or yellow	-
bat	large	white	fruity

The chart below classifies five flowers A, B, C, D and E.

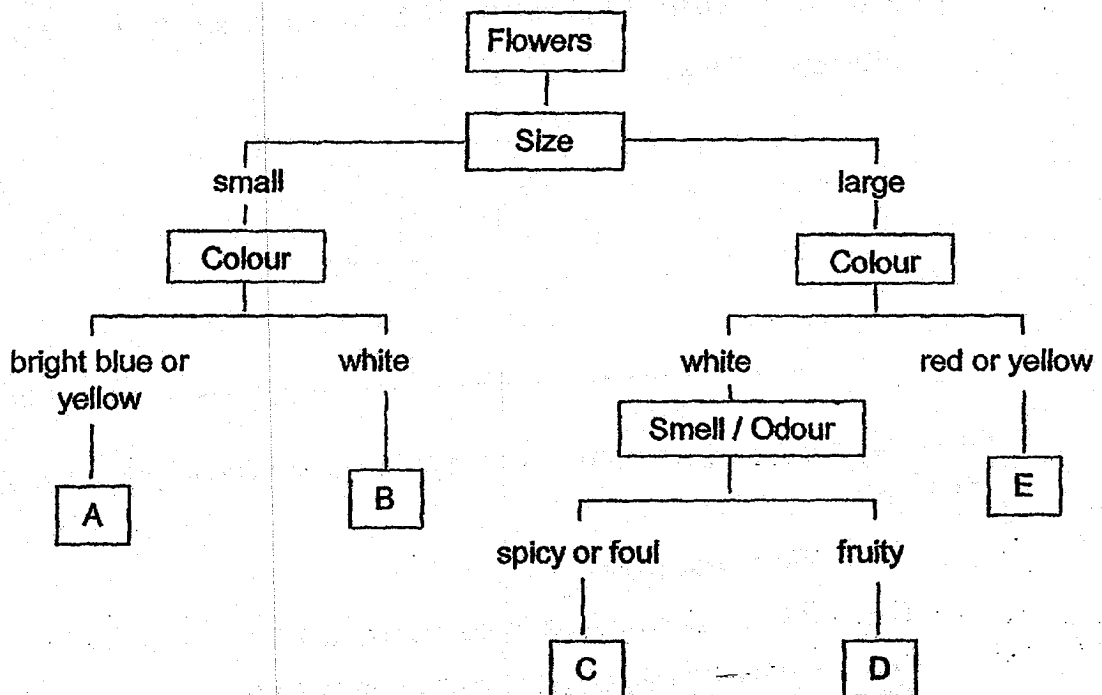

What animals would be attracted to flowers B and D respectively?

	Flower B	Flower D
(1)	bird	beetle
(2)	moth	bat
(3)	bat	bird
(4)	moth	beetle

8. Study the food chain shown below.

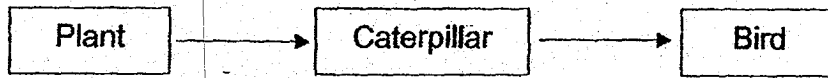

What is the main source of energy for the food chain?

- (1) Sun
 - (2) Plant
 - (3) Water
 - (4) Carbon dioxide
9. The graph below shows the population of bees in a community over a period of time.

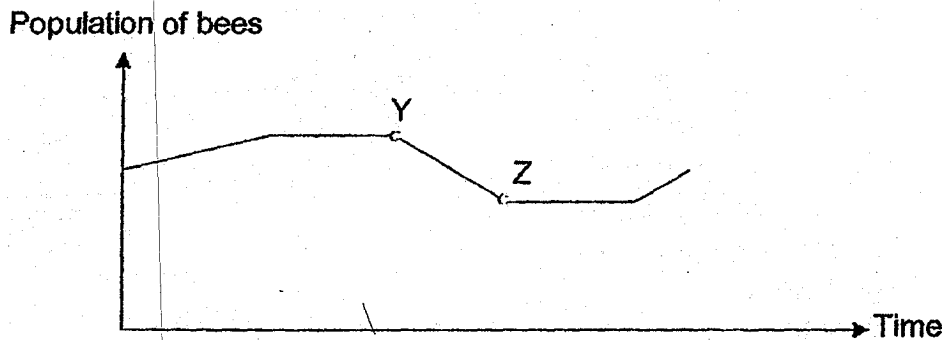

Which of the following explains the change in the population of bees shown by YZ in the graph?

- A There was a drought.
 - B Butterflies were introduced to the habitat.
 - C More land was used for building of houses.
 - D A disease had infected on some of the flowering plants.
- (1) A and B only
 - (2) C and D only
 - (3) B and D only
 - (4) A, B, C and D

10. Which one of the following adaptive features of the organisms is incorrectly matched to its function?

	Organism	Adaptive feature	Function of adaptive feature
(1)	Owl	night vision	to be able to hunt at night
(2)	Fish	streamlined body	to be able to swim fast in water
(3)	Penguin	huddle together	to keep its body warm
(4)	Frog	webbed feet	to grip onto its prey

11. The diagram below shows the cross-section of a deep pond.

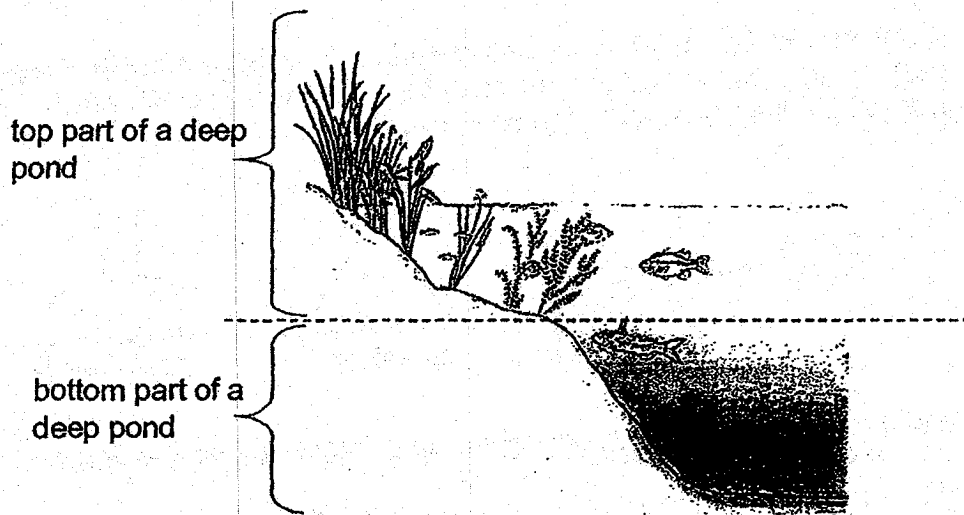

There are more aquatic plants found at the top part of the deep pond. What is the main reason for such an observation?

- (1) The aquatic plants can get sufficient nutrients to grow well.
- (2) The aquatic plants can absorb more sunlight for photosynthesis.
- (3) The aquatic plants can take in oxygen from the air above the water.
- (4) The aquatic plants can provide shade and shelter for the aquatic animals living in the pond.

12. Study the diagram below.



Which of the following substances will be returned to the environment and be recycled?

- (1) Mineral salts only.
- (2) Mineral salts and water only.
- (3) Carbon dioxide and mineral salts only.
- (4) Carbon dioxide, mineral salts and water.

13. Jody poured 200 ml of water into container P as shown in the diagram below. She then poured all the water from container P to container Q. All the water was then poured out from container Q to container R.

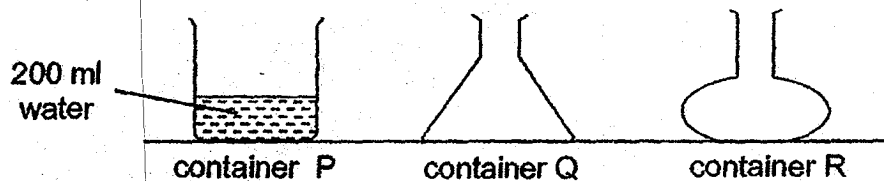

Which of the following best describes what Jody was trying to find out?

- (1) She was trying to find out if water has definite mass.
- (2) She was trying to find out if water has a definite shape.
- (3) She was trying to find out if water has a definite volume.
- (4) She was trying to find out if water has definite mass and shape.

14. The diagram below shows three identical beakers X, Y and Z. Three pieces of plasticine of different sizes were placed into the beakers. The beakers were then filled to the brim with water.

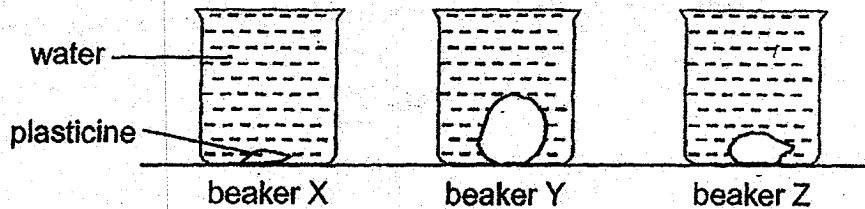

Which one of the following shows the most likely amount of water added into each beaker?

	Amount of water (ml)		
	X	Y	Z
(1)	260	480	390
(2)	480	390	260
(3)	480	260	390
(4)	390	480	260

15. Mei Ling wanted to investigate whether the size of a magnet affects the greatest distance it can attract a paper clip.

Which of the following variables should she keep constant?

- A Size of magnet
 - B Type of magnet
 - C Size of paper clip
 - D Type of paper clip
 - E Distance between magnet and paper clip
- (1) A only
- (2) B, C and D only
- (3) A, B, D and E only
- (4) B, C, D and E only

16. The diagram below shows a wooden rod with a magnet P and iron ball Q hanging from a rope.

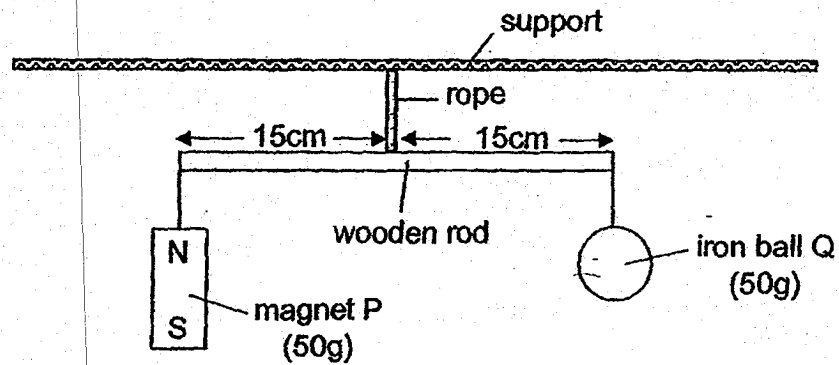

Which one of the following statements is **false**?

- (1) When the north pole of another magnet is placed under magnet P, the wooden rod will tilt towards magnet P.
- (2) When the north pole of another magnet is placed under iron ball Q, the wooden rod will tilt towards magnet P.
- (3) When the south pole of another magnet is placed under magnet P, the wooden rod will tilt towards iron ball Q.
- (4) When the south pole of another magnet is placed under iron ball Q, the wooden rod will tilt towards iron ball Q.

17. Jim placed a coin at the bottom of a beaker as shown in the diagram below. He then poured some water from river X into the beaker slowly and observed the coin from above the beaker. He stopped pouring when he could not see the coin clearly and recorded the amount of water in the beaker.

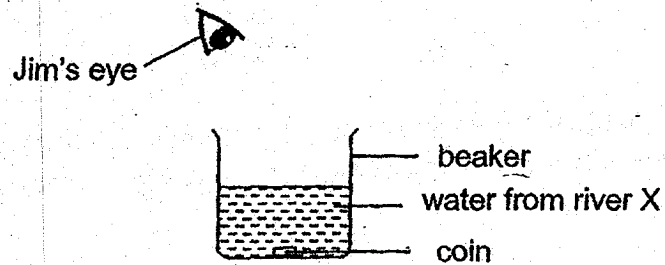

He repeated the same experiment with water from rivers Y and Z. The table below shows the results.

	Amount of water in the beaker (ml)
River X	250
River Y	160
River Z	370

Based on Jim's results, which of the following shows the clarity of water from rivers X, Y and Z in the correct order?

	Clearest	→	Least Clear
(1)	X		Y Z
(2)	Y		X Z
(3)	Z		X Y
(4)	Z		Y X

18. Study the set-up below.

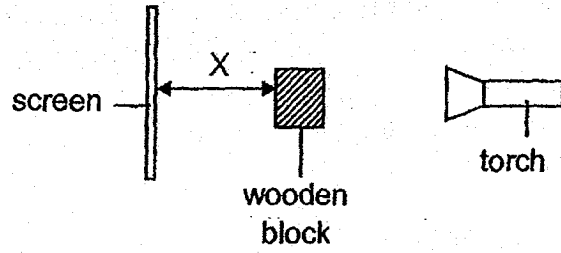

Based on the diagram above, which one of the following graphs shows the relationship between X and the length of the shadow observed on the screen?

(1)

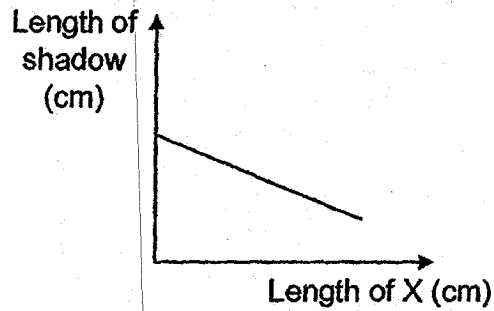

(2)

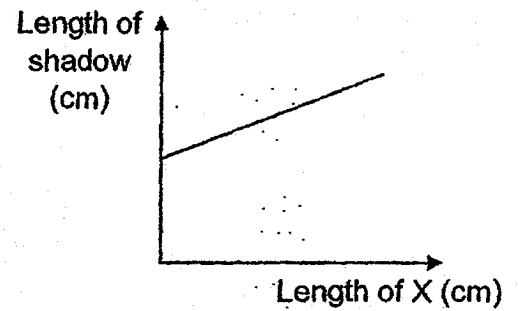

(3)

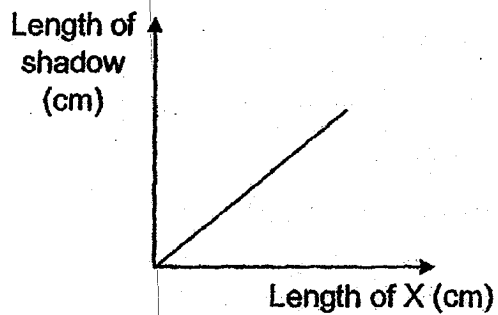

(4)

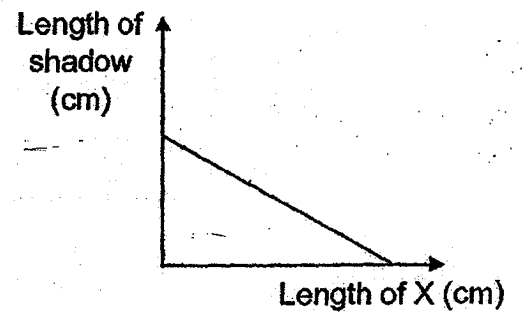

19. Study the flow chart below.

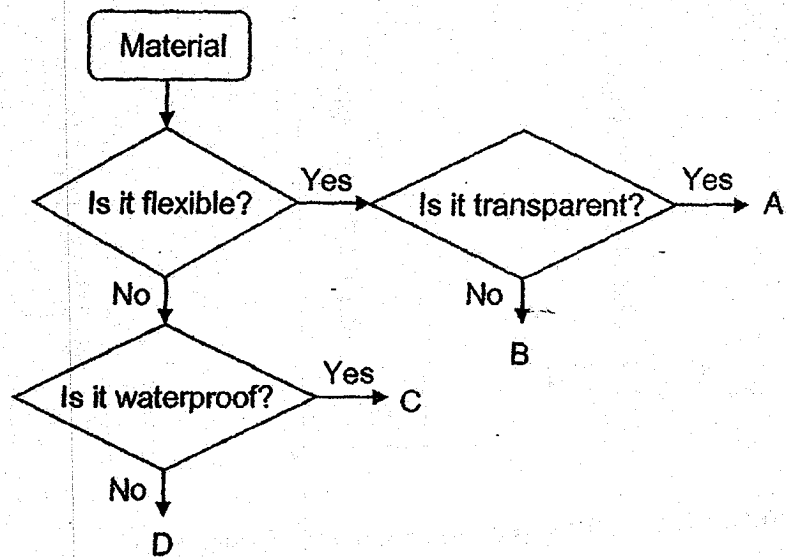

Which one of the following best represents A, B, C and D?

	A	B	C	D
(1)	styrofoam board	t-shirt	metal key	glass cup
(2)	wooden plank	metal bowl	rubber band	plastic folder
(3)	plastic folder	rubber band	metal bowl	wooden plank
(4)	cellophane paper	coloured paper	metal key	styrofoam board

20. Four masses were tied to four ropes made from different materials J, K, L and M as shown in the diagram below. The ropes were all of similar thickness. When the masses were lifted by the ropes, ropes K and L broke.

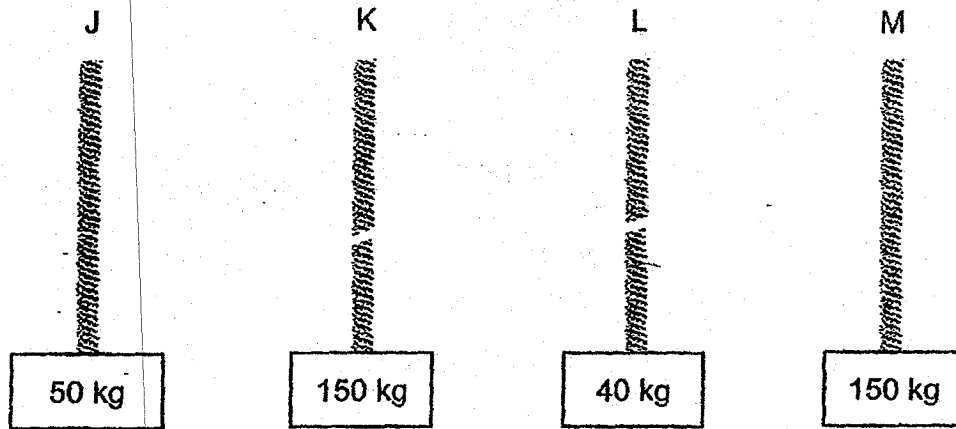

Which of the following statements is definitely true?

- A Material L is the weakest.
 - B Material M is the strongest.
 - C Material J is stronger than material L.
 - D Material K is weaker than material M.
- (1) A and B only
(2) C and D only
(3) A, C and D only
(4) A, B, C and D

21. A study was conducted to identify the factors that affect the evaporation rate of some liquids. The table below shows the results of the investigation.

Type of liquid	Exposed surface area (cm ²)	Initial amount (ml)	Amount evaporated after 1 week of exposure (ml)			
			Trial 1	Trial 2	Trial 3	Average
Water	12	40	9.3	9.2	8.8	9.1
Water	8	60	6.3	5.9	6.2	6.1
Water	4	80	2.8	3.1	2.9	2.9
Alcohol	4	80	9.1	8.8	8.9	8.9
Alcohol	8	80	18.6	18.1	17.8	18.2
Orange juice	4	80	2.7	3.2	3.2	3.0

Based on the data above, which of the following statements is not correct?

- (1) The evaporation rate for water is less than that for alcohol.
- (2) The larger the amounts of water the higher the evaporation rate.
- (3) Water has approximately the same evaporation rate as orange juice.
- (4) The larger exposed surface areas of water had greater evaporation rates.

22. When John put the flask of tap water into a container of boiling water, he observed that the water level in the glass tube fell first before it rose.

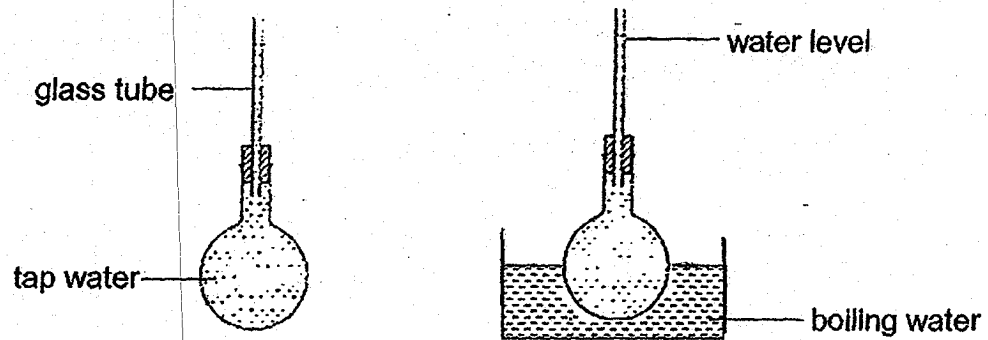

Which one of the following best explains his observation?

- (1) Tap water is a good conductor of heat.
- (2) Glass is a poorer conductor of heat than tap water.
- (3) The flask expands before the water in the flask expands.
- (4) The flask contracts causing the water level in the tube to fall.

23. An inflated balloon was attached to a wooden block and placed in a container of water at 26 °C as shown in the diagram below.

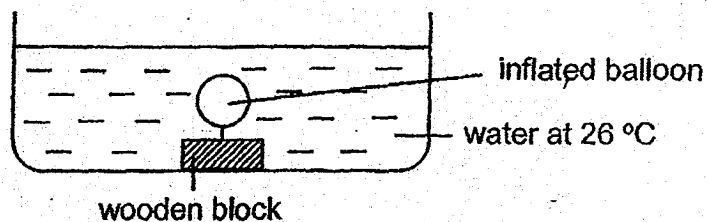

Which one of the following shows the most likely observation and corresponding explanation when the water in the container was heated to 65 °C?

	Observation(s)	Explanation
(1)	The balloon remained the same size.	Heat did not cause any visible change in the set-up.
(2)	The balloon became smaller.	Some air had escaped from the balloon causing it to reduce in size.
(3)	The balloon became bigger.	Some air from the water had entered the balloon causing it to expand.
(4)	The balloon became bigger and the water level in the container increased.	Both the air in the balloon and the water in the container gained heat and expanded.

24. Benjamin carried out an experiment using four set-ups A, B, C and D as shown below. The water in all the beakers were at room temperature at first.

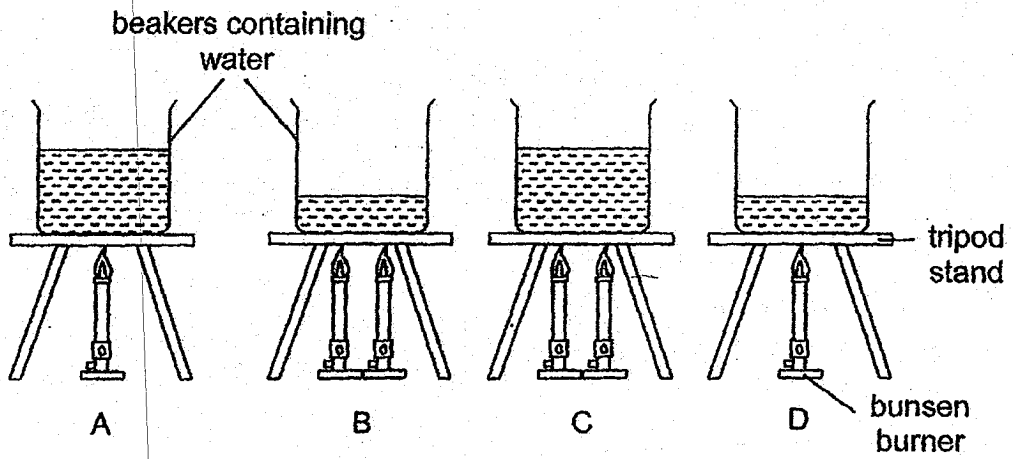

In which set-up would the temperature of water be the lowest after 10 minutes of heating?

- (1) A
- (2) B
- (3) C
- (4) D

25. The diagram below shows a circuit with three similar bulbs A, B and C.

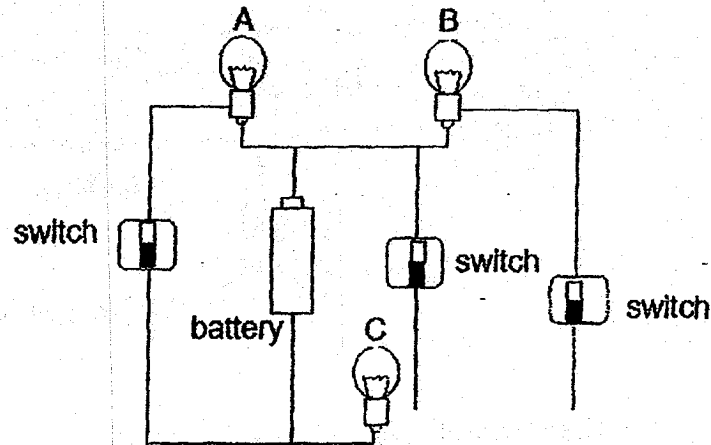

If only bulbs B and C are lit, which one of the following circuit diagrams correctly represents the circuit above?

(1)

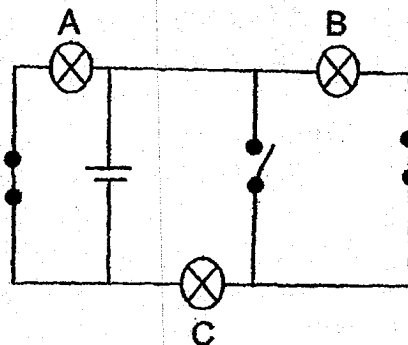

(2)

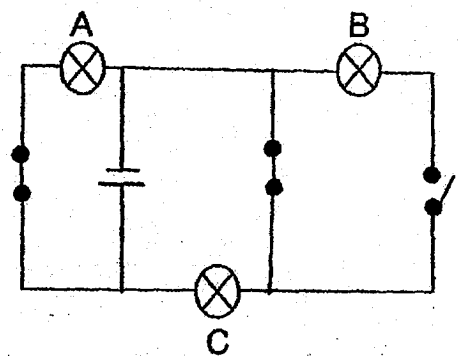

(3)

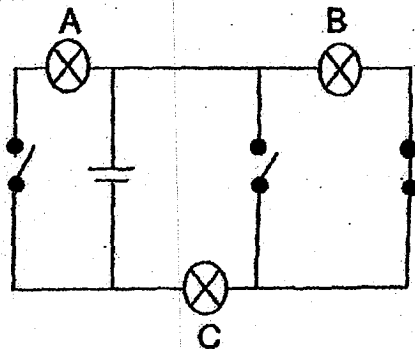

(4)

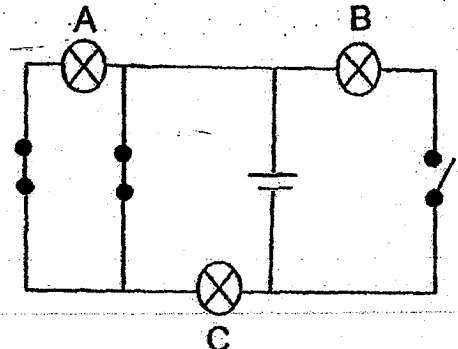

26. A fan and a container of water were connected to a circuit as shown below.

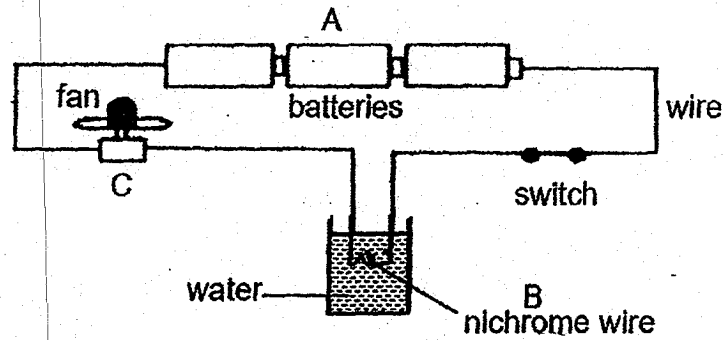

When the switch was closed, the fan started moving and the water in the container was slowly heated up.

What were the main energy changes that had taken place at each point labelled A to C?

	A	B	C
(1)	Chemical potential energy → electrical energy	Electrical energy → light energy	Kinetic energy → sound energy
(2)	Electrical energy → kinetic energy	Electrical energy → light energy	Electrical energy → sound energy
(3)	Chemical potential energy → electrical energy	Electrical energy → heat energy	Electrical energy → kinetic energy
(4)	Electrical energy → kinetic energy	Heat energy → light energy	Kinetic energy → heat + sound energy

27. The diagram below shows a man throwing a ball.

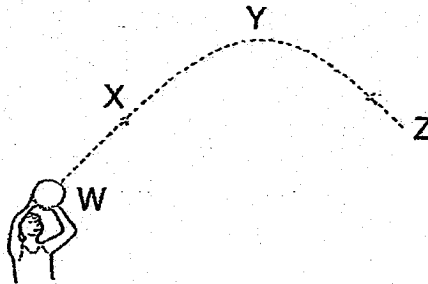

Which of the following statements is / are true?

- A At point W, there is no force acting on the ball.
- B At point X, ball slows down because of gravity.
- C At point Y, the ball starts to drop as no force is acting on it.
- D At point Z, the ball drops further as frictional force is acting on it.

- (1) B only
- (2) A and B only
- (3) C and D only
- (4) A, B and D only

28. The diagram below shows a helicopter during the different stages of its flight.

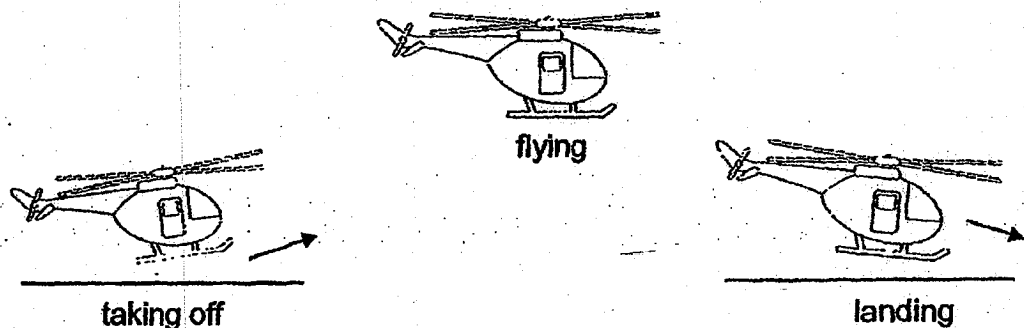

At which stage(s) does gravity act on the helicopter?

- (1) Landing only
- (2) Taking off and flying only
- (3) Taking off and landing only
- (4) Taking off, flying and landing

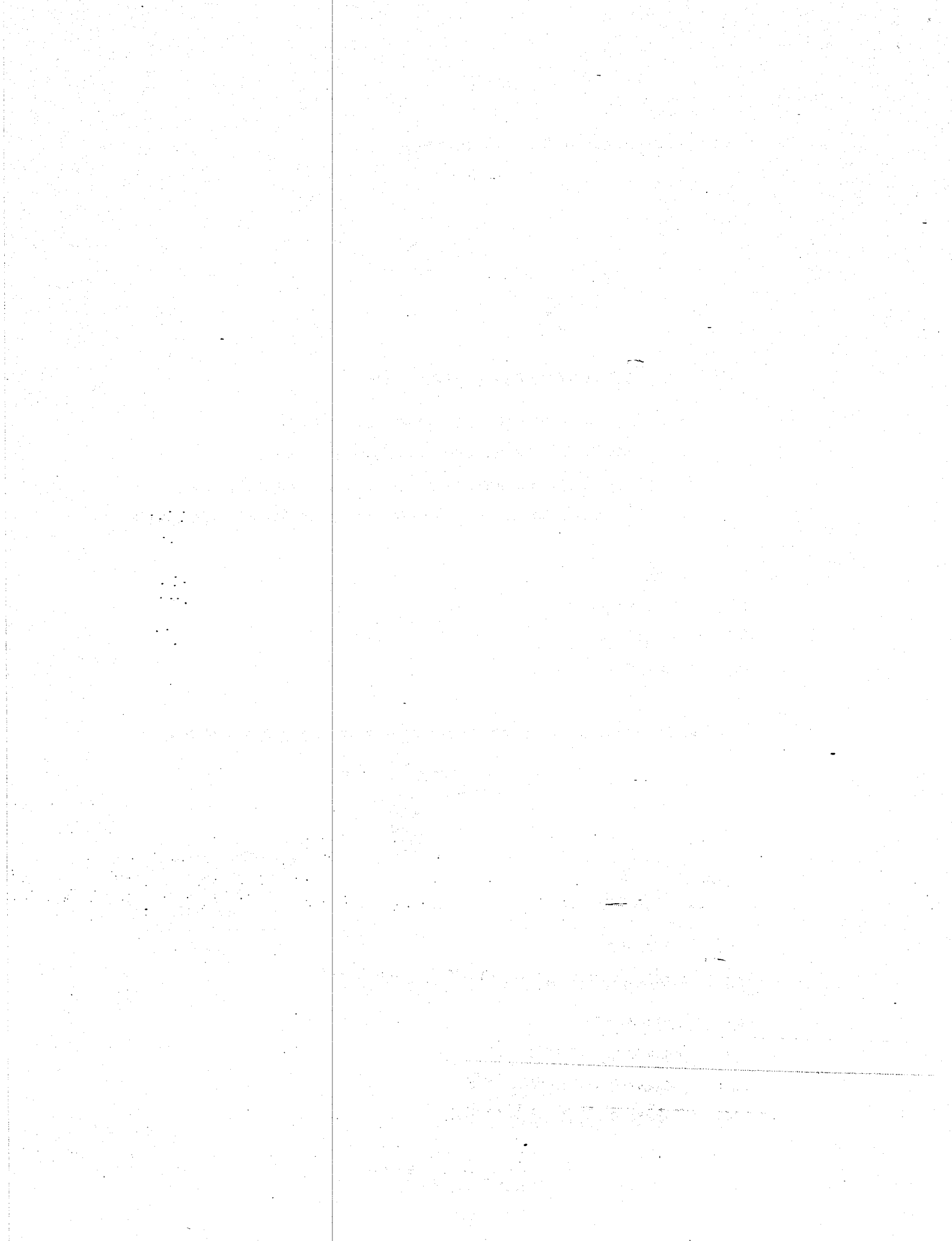

Name : _____ ()

Class : Primary 6 _____

CHIJ ST NICHOLAS GIRLS' SCHOOL

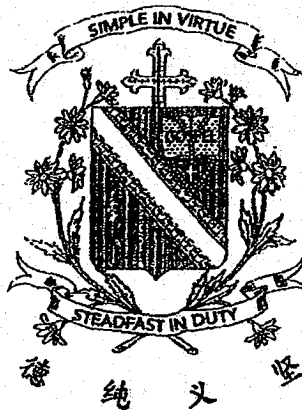

Primary 6

Preliminary Examination
SCIENCE

BOOKLET B

22 August 2019

Total Time for Booklet A and B: 1 hour 45 minutes

13 questions
44 marks

Do not open this booklet until you are told to do so.
Follow all instructions carefully.
Answer all questions.

This paper consists of 15 printed pages.

Booklet A	56
Booklet B	44
Total	100

Parent's Signature

For questions 29 to 41, write your answers in this booklet.

The number of marks available is shown in the brackets [] at the end of each question or part question. (44 marks)

29. Mary carried out an experiment to find out whether light is needed for photosynthesis.

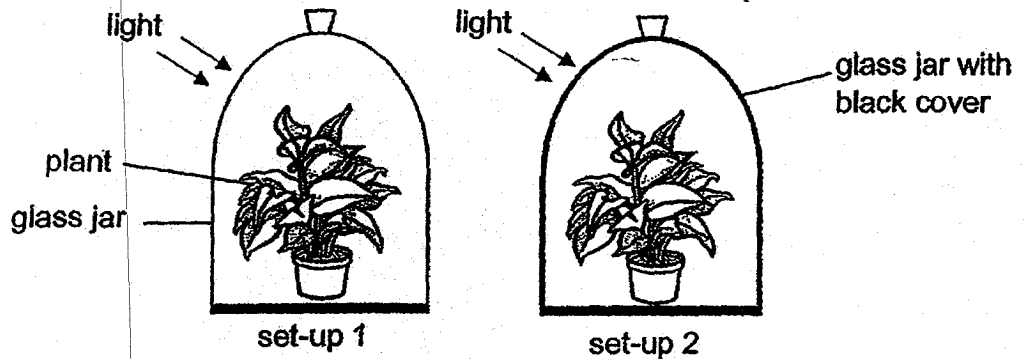

(a) What is the purpose of set-up 1? [1]

(b) Based on her experiment, how can Mary confirm that light is needed for photosynthesis? [2]

(c) What is produced during photosynthesis that is needed by the plant? [1]



30. A gardener observed a food relationship in his garden.

plant K \longrightarrow insect A

The gardener learnt that another insect, M, is a predator of insect A. Insect M also likes to feed on pollen. Using this information, he decided to grow plant H around plant K, as shown below.

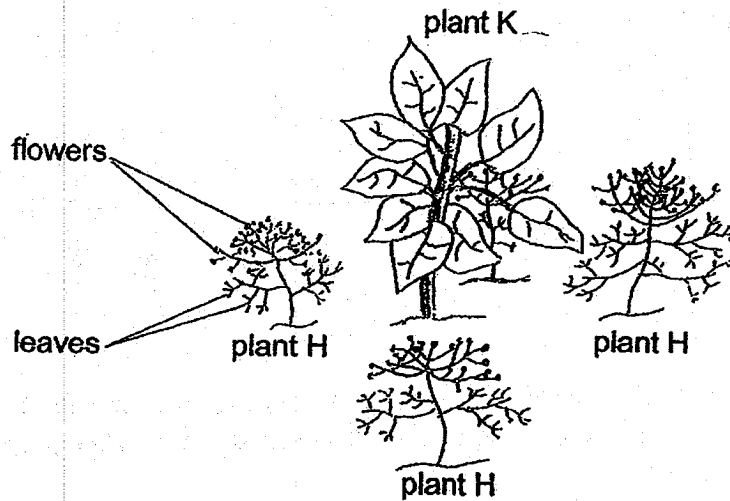

Based on the information above, explain how this planting method allows the gardener to grow plant K without the use of pesticides? [2]



31. The graph below shows the number of animal F and animal G in a community.

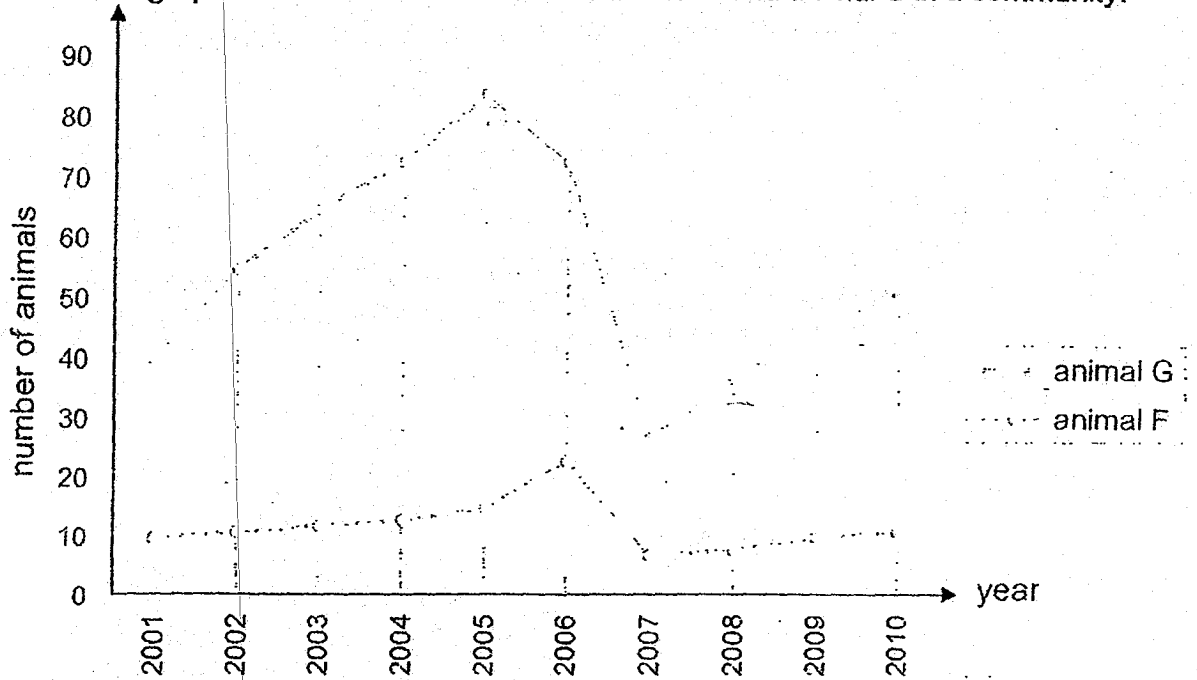

(a) Animal F and G have a prey-predator relationship. Based on the graph above, which animal is a prey and which is a predator? [1]

Prey: _____

Predator: _____

(b) Based on the graph given above, there was a period with very little rainfall.

This most likely happened from _____ to _____. [1]

(c) Other than lack of water for the predator, give another possible reason why with very little rainfall would cause a decrease in the population of the predator. [1]

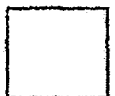

32. Halim wanted to conduct an experiment to find out if plastic is harmful to the environment. He buried a plastic box and a paper box for a month. Every week, Halim dug out the boxes to observe them.

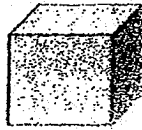

plastic box

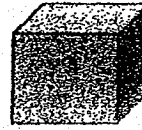

paper box

- (a) Besides the size of the boxes, state two other variables that he should keep the same in order for it to be a fair test. [1]

- (b) The results of Halim's experiment showed that the plastic box remained the same condition while the paper box had broken down into smaller pieces. Which of the following statements is supported by the results of Halim's experiment? Put a tick in the box next to the correct statement. [1]

Statement	Correct
Plastics can kill wildlife.	<input type="checkbox"/>
Plastics cause global warming.	<input type="checkbox"/>
Plastics remain as waste in our environment.	<input type="checkbox"/>
Plastics release harmful gases when they break down.	<input type="checkbox"/>

- (c) State one way that we can help to reduce plastic waste in our environment. [1]



33. The diagram below shows organism B using its long proboscis to obtain nectar from a flower. It will curl up its proboscis when it flies from flower to flower. Other than nectar, organism B also feeds on honey. It will mimic the scent of the bees in order to enter the beehives to consume the honey. It has clawed feet that help it to climb around the beehives easily. When met with predators, organism B will flash its brightly coloured abdomen to frighten them away.

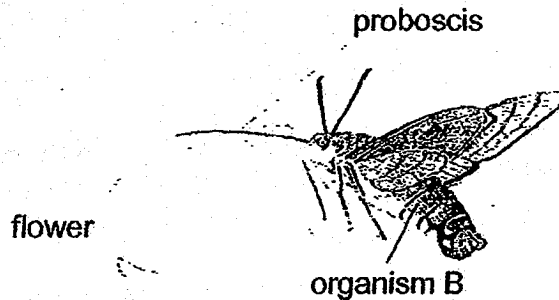

- (a) Based on the information above, state one structural and one behavioural adaptation of organism B that allow it to obtain food. [1]

Structural adaptation: _____

Behavioural adaptation: _____

- (b) Organism B usually feeds at night. How will feeding at night benefit organism B? [1]

- (c) State one reason why organism B mimics the scent of the bees when entering the beehives. [1]



- (d) The forest where organism B lives in is being cleared for building of new houses. How will this affect the population of Organism B? Explain your answer. [1]

- (e) Deforestation can also lead to global warming. Explain why. [1]

34. The diagram below shows a table fan.

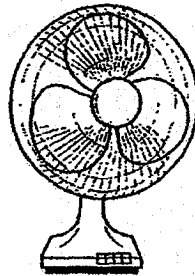

- (a) Complete the conversion of energy when the switch is turned on. [1]

Electrical energy → + +
energy energy energy

- (b) Explain why the fan continued to spin for a while even after the switch was turned off. [1]

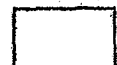

35. Nathan made paper flyer A with a paper clip as shown in the diagram below.

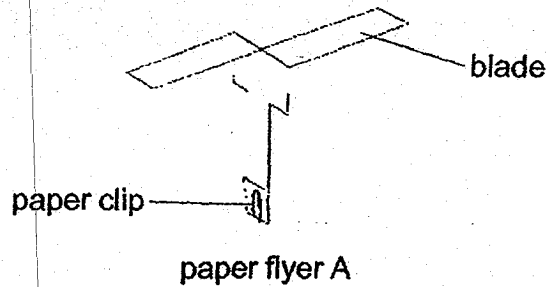

He wanted to find out if the number of paper clips on paper flyer A would affect the time it took to fall to the ground.

- (a) What must Nathan measure to help him draw a conclusion? [1]

Nathan threw paper flyer A with one paper clip and measured the distance it travelled. He then trimmed off 1 cm from each of the two blades of paper flyer A and measured the distance it travelled when it was thrown from the same height.

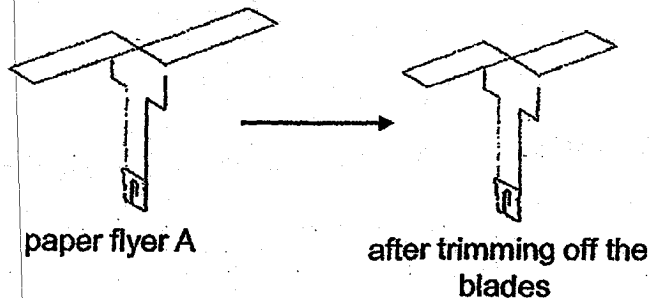

- (b) Would the distance travelled by paper flyer A be affected after the blades were trimmed? Explain your answer. [2]

- (c) Name one fruit or seed with a similar structure like paper flyer A. [1]

8

36. Lennard used an open-top cardboard box and a balloon to make a toy as shown below. He then used it to investigate if the size of the balloon would affect the distance moved by the toy.

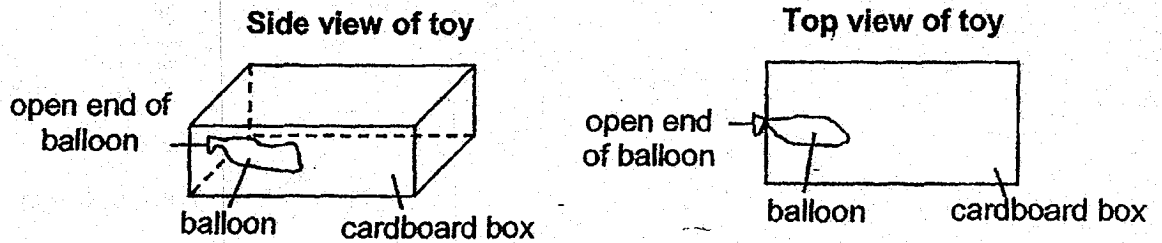

He inflated the balloon with some air before twisting the open end of the balloon and holding it between his fingers. He then placed the toy on the floor and released his grip on the balloon. Immediately, the toy moved a distance away from him. He then measured the distance moved by the toy.

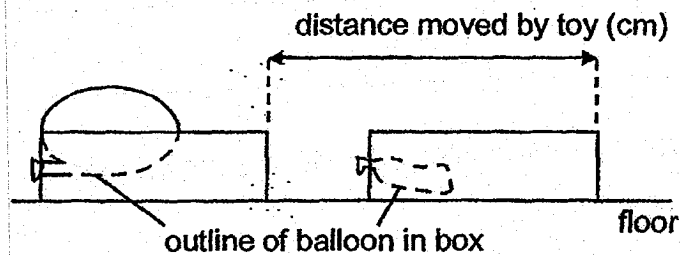

Lennard then inflated the balloon with more air and repeated the experiment. He noted that the toy moved a greater distance.

- (a) What can Lennard do to make his experimental results more reliable? [1]

Lennard made some modifications to his experiment as shown in the diagram below.

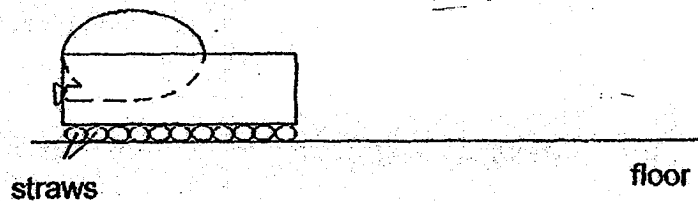

- (b) Would the toy move a shorter or longer distance than before? Explain why. [2]

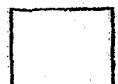

37. Study the set-up below.

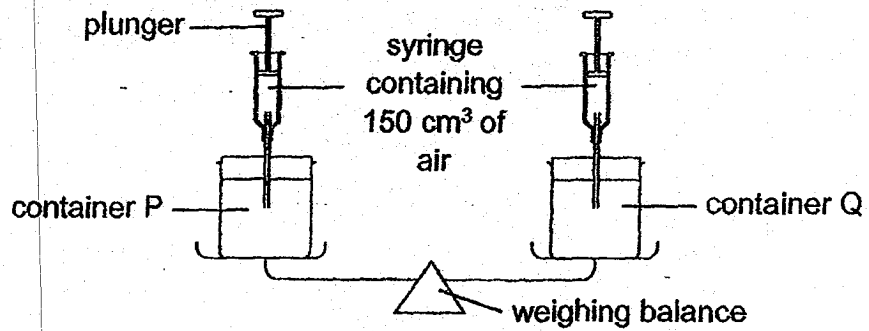

(a) What would be observed when 150 cm³ of air was pumped into container Q? [1]

(b) State one property of air demonstrated by the experiment above. [1]

Thomas set up an experiment as shown below.

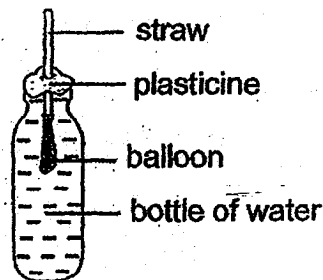

(c) Thomas tried to inflate the balloon by blowing through the straw. Would the balloon inflate? Give a reason for your answer. [1]



38. Alisha placed a square piece of red filter in front of a torch as shown in diagram 1.

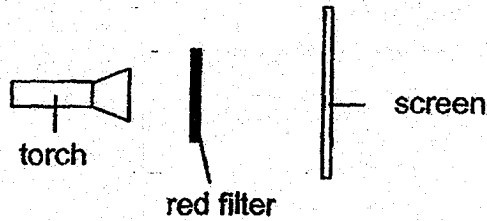

diagram 1

When the torch was switched on, she noted a square patch of light on the screen. She then repeated the same experiment with blue and green filters.

Colour of filter used	Colour of square patch of light
red	red
blue	blue
green	green

(a) What was the aim of Alisha's experiment?

[1]

Alisha then placed a can of drink behind a red filter as shown in diagram 2.

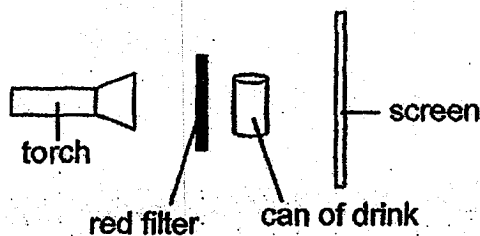

diagram 2

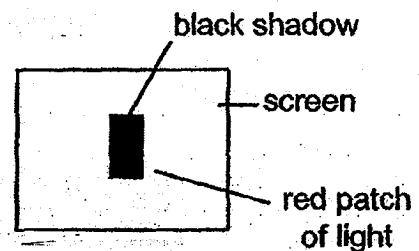
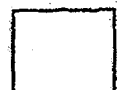

diagram 3

(b) Diagram 3 shows what she saw on the screen when the torch was switched on. Give an explanation for Alisha's observations in diagram 3.

[2]



39. Wen Xiong wanted to set up a circuit to light up a hall using two special switches. Switch 1 can be turned to positions A or B and switch 2 can be turned to positions C or D. He set up the circuit so that the bulb will be lit as described in the table below.

Position of switch		Bulb X is lit
Switch 1	Switch 2	
A	C	Yes
A	D	Yes
B	D	No
B	C	No

- (a) The diagram below shows part of the circuit. Complete the circuit so that it will work as described. [2]

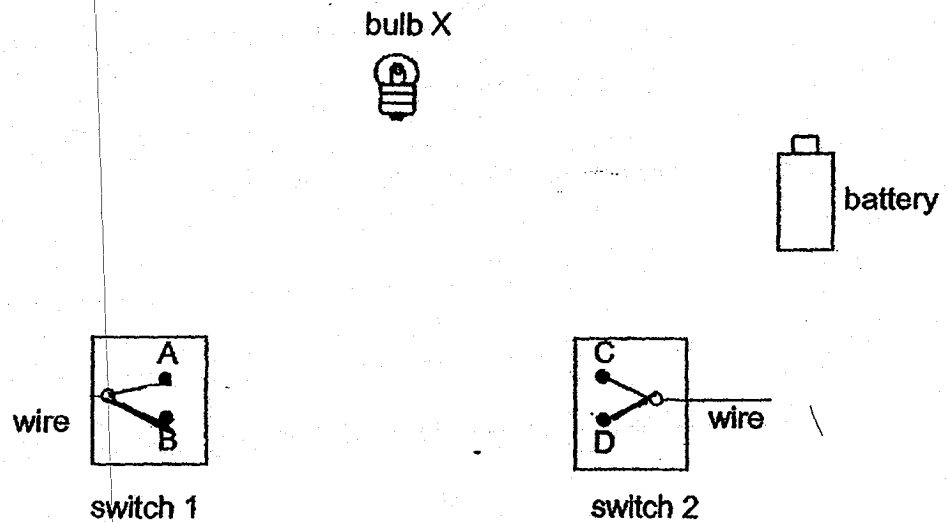

- (b) If one more bulb is added to the circuit in series, how would it affect the brightness of bulb X? [1]



40. Hussein used a water collector to collect some water while on a trip to a desert. He placed the water collector in an open area in the evening and collected the water in the morning.

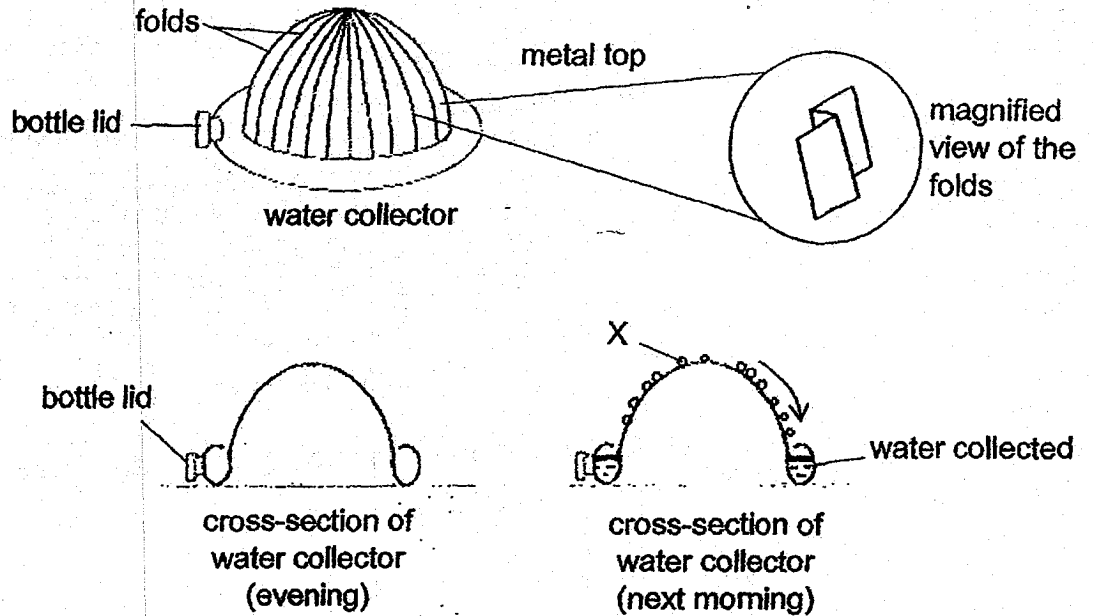

- (a) What is X? [1]

- (b) Explain why metal is used to make the top part of the water collector. [2]

- (c) Explain why there are folds in the metal top. [2]

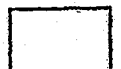

41. The diagram below shows water heater A. The heating coil inside the tank is able to heat the water up to a temperature of $49\text{ }^{\circ}\text{C}$ when the heater is turned on. The temperature of the water is then maintained at $49\text{ }^{\circ}\text{C}$ until the heater is switched off. When the hot water tap is turned on, cold water enters the tank to replace the water used.

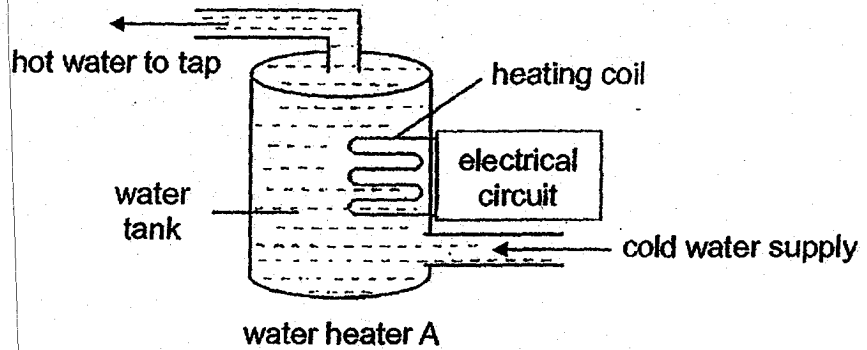

The graph below shows the temperature of the water in the tank over a period of time.

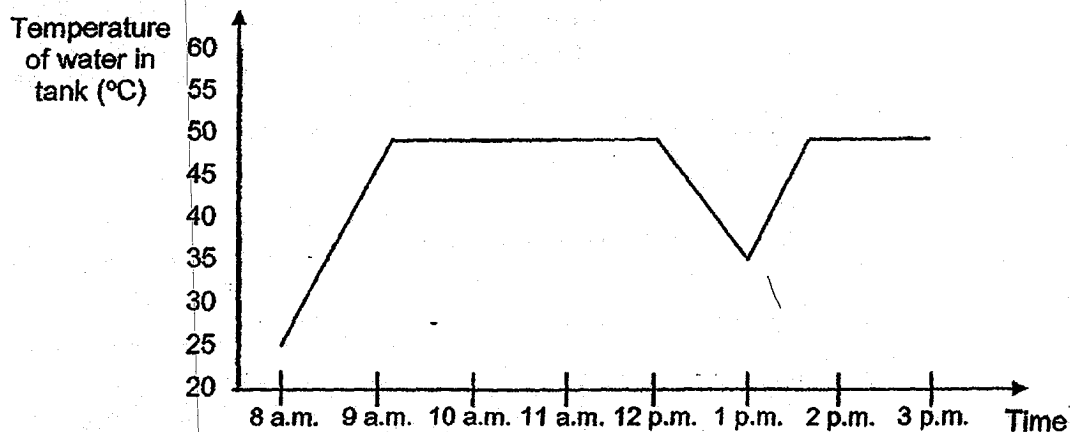

- (a) How long does it take for the water in the tank to heat up to $49\text{ }^{\circ}\text{C}$? [1]

- (b) Jia Ming took a bath during the period shown in the graph. Based on the graph above, what time did he probably take his bath? [1]



- (c) While bathing, Jia Ming noticed that the temperature of the water was not as hot as when he started bathing. Give a reason why this is so. [1]

The diagram below shows water heater B. This type of water heater does not store water in a tank. When hot water is needed, the heater is switched on and cold water passes through the heater to be warmed up before leaving the heater. The water heater takes about 5 minutes to heat up the water to a temperature of 49 °C.

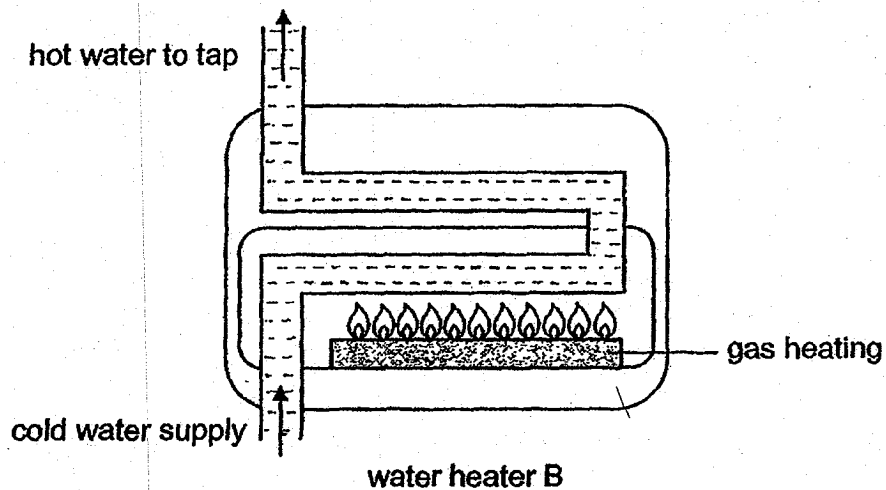

- (d) Which water heater A or B is more energy saving? Explain your choice. [1]



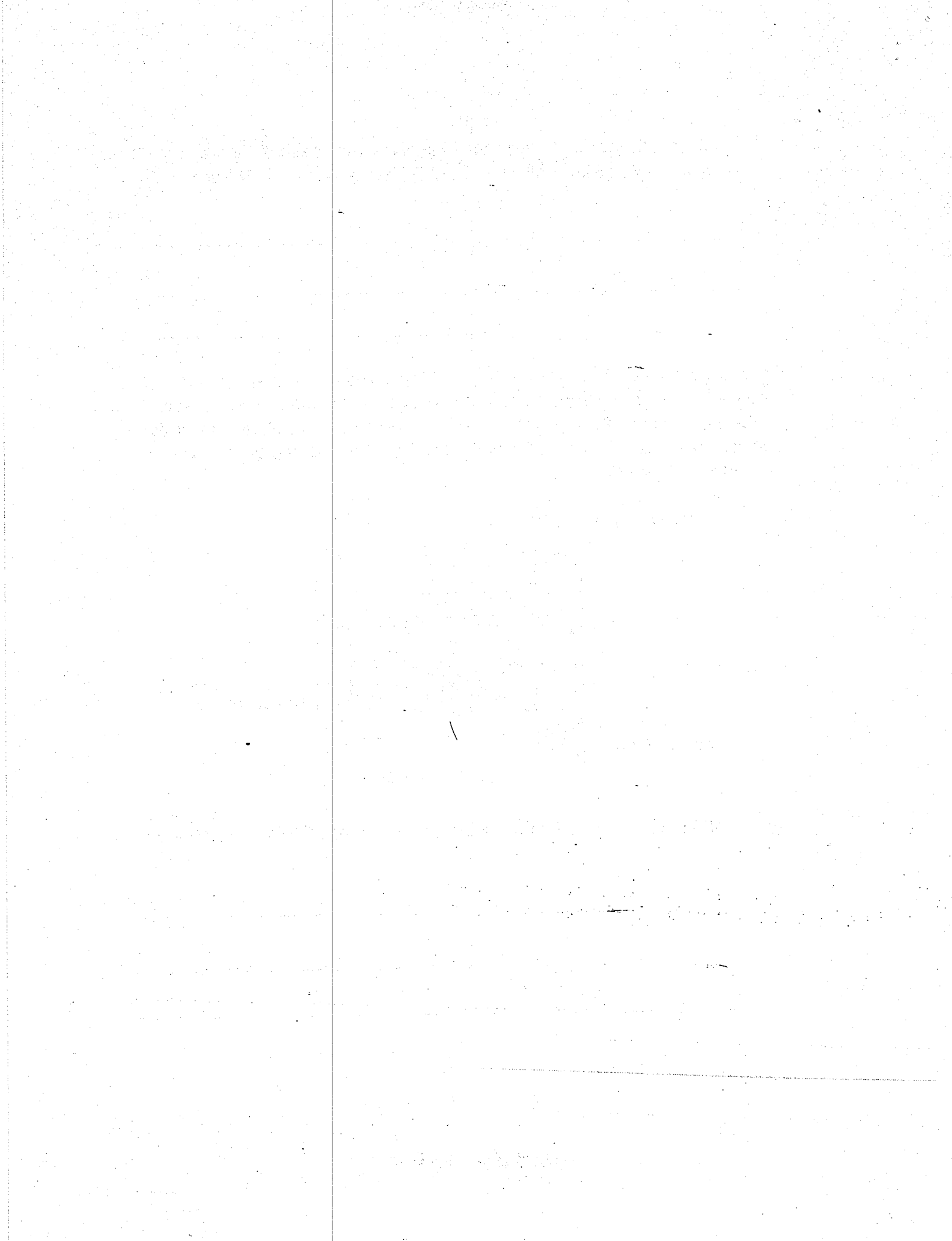

SCHOOL : CHIJ PRIMARY SCHOOL
LEVEL : PRIMARY 6
SUBJECT : SCIENCE
TERM : 2019 PERLIM

SECTION A

Q 1	Q2	Q3	Q4	Q5	Q6	Q7	Q8	Q9	Q10
4	2	3	3	3	3	2	1	4	4
Q 11	Q12	Q13	Q14	Q15	Q16	Q17	Q18	Q19	Q20
2	4	2	3	2	2	3	2	3	2
Q 21	Q22	Q23	Q24	Q25	Q26	Q27	Q28		
2	3	4	1	3	3	1	4		

SECTION B

Q29)	<p>a)To act as a control set-up to show that light is needed for photosynthesis to take place.</p> <p>b)Take a leaf from each set-up and when photosynthesis takes place, starch will be present in the leaf. Test the presence of starch by Iodine test. The leaf in set-up 1 will turn blue-black which shows the presence of starch while the leaf in set-up 2 turn yellowish-brown which means there is no starch in set-up 2. Therefore, light is needed for photosynthesis to take place.</p> <p>c)Glucose and oxygen.</p>
Q30)	<p>Insect M will feed on Insect A. The population of insect A will decrease and population of K will increase. Insect M will also help to pollinate plant K, causing plant K to grow without the use of pesticides.</p>
Q31)	<p>a)Prey : G Predator : F</p> <p>b)2006 to 2007</p>

	<p>c)G also needs water to respire and carry out life processes so without water, G dies. As the population size of G decreases, lesser food is available for F, so the population size of F also decreases.</p>
Q32)	<p>a)i)The type of soil they are buried in. ii)The depth of the hole, the boxes are buried.</p> <p>b)Plastic remain as waste in our environment.</p> <p>c)Use lesser things made from plastic. Instead, use recyclable materials such as cloth bags instead of plastic bags.</p>
Q33)	<p>a)Structural adaptation : B has clawed feet that help it climb around the beehives easily. Behavioural adaptation : B mimics the scent of bees in order to enter the beehives to consume the honey.</p> <p>b)During feeding at night, organism B will flash its brightly coloured abdomen to frighten its predator away. The colours can be seen easily at night. Thus, it will be safe to feed at night.</p> <p>c)The bees would attack any intruder like B but the bees are fooled by B's mimicry of their scent so the bees think B is another bee and will not attack.</p> <p>d)The population size of B would decrease. When the forest is cleared, bees cannot build their beehives and not as many flowers can grow. B will have lesser food and no shelter.</p> <p>e)When deforestation happen, trees are cut down and lesser trees to photosynthesize. When the rate of photosynthesis slows down, more carbon dioxide is present in the air, More heat is trapped when there is more carbon dioxide. Thus, causes global warming.</p>
Q34)	<p>a)Electrical energy → Kinetic energy + sound energy + heat energy</p> <p>b)The kinetic energy of the blades was still converting into sound and heat energy.</p>
Q35)	<p>a)The time taken for the paper flyer A to reach the ground.</p> <p>b)The distance travelled by A after the blades were trimmed would be shorter. There will be lesser air resistance between the shorter blades and the air so gravitational force will overcome frictional force more easily, thus A with shorter blades cannot travel as far.</p>

	c)African tulip.
Q36)	<p>a)Repeat the experiment a few more times and take the average results.</p> <p>b)A longer distance. The straws have air spaces between them, so the new set-up has lesser friction between the floor and the toy, hence lesser frictional force needs to be overcome.</p>
Q37)	<p>a)The scale will still be balanced.</p> <p>b)Air can be compressed.</p> <p>c)No, the balloon will not inflate. The water in the bottle has a definite volume and cannot be compressed or displaced by and air blown into the balloon.</p>
Q38)	<p>a)To find out different colour filters would affect the colour of light produced.</p> <p>b)The can is opaque and blocks more light than the translucent filter. As light travels in a straight line, the can will block the light in its path and form a shadow. The filter only partially blocks light so its shadow is faint.</p>
Q39	<p>a)</p> <p>The diagram shows a series circuit. On the right, a battery is connected to a wire that goes to terminal C of switch 2. From terminal C, a wire goes to terminal A of switch 1. From terminal A, a wire goes to the top terminal of bulb X. From the bottom terminal of bulb X, a wire goes to terminal B of switch 1. From terminal B, a wire goes to terminal D of switch 2. From terminal D, a wire goes back to the bottom terminal of the battery. The switches are shown in an open position.</p>

	b)The brightness of X would decrease.
Q40)	<p>a)Water droplets.</p> <p>b)Metal is a good conductor of heat contact , so it would gain heat from the surrounding water vapour faster to allow more water vapour to process condense into more water droplets so more water is produced.</p> <p>c)This is so the metal top has more surface area in contact with more water vapour in the air so there will be a higher rate of condensation and more water will be produced.</p>
Q41)	<p>a)1 hour</p> <p>b)At 12p.m.</p> <p>c)As hot water leaves the water tank when Jia Ming is bathing, the cold water will enter the water tank to fill up the space. It takes time for the cold water to gain heat from the heating coil but cold water keeps entering the tank when tap is on. So it will not reach 49° C instantly so not so hot as when he started bathing.</p> <p>d)B. B only takes 5 minutes to heat water up to 49°C whereas A takes 1 hour and the amount of heated water is finite.The water is heated up only when needed.</p>