



YUYING SECONDARY SCHOOL
PRELIMINARY EXAMINATION
 Secondary 4 Express / 5 Normal (Academic)

NAME

CLASS

REG. NO

SCIENCE**5076/1, 5077/1**

Physics

29 August 2017

30 minutes

Candidates answer on the Multiple Choice Answer Sheet.
 Additional Materials: Multiple Choice Answer Sheet

Setter: Mr Jameson Kang**READ THESE INSTRUCTIONS FIRST**

Write your name, class and register number on this question booklet and the separate Answer Sheet.

There are **twenty** questions in this section. Answer **all** questions.

For each question there are four possible answers **A, B, C** and **D**.

Choose the one you consider correct and record your choice in **soft pencil** on the separate Answer Sheet.

Each correct answer will score one mark. A mark will not be deducted for a wrong answer.

Read the instructions on the Answer Sheet very carefully.

Each correct answer will score one mark. A mark will not be deducted for a wrong answer.

Any rough working should be done in this booklet.

The use of an approved calculator is expected, where appropriate.

For Examiner's Use	
Total	20

Answer **all** the questions in this section on the separate Answer Sheet.
The total mark for this section is 20.

1. Which of the following is a vector quantity?
- A. speed
B. mass
C. acceleration
D. heat
2. The following shows the displacement-time graph of a cyclist who cycled towards the end of the park and returned to the start point.

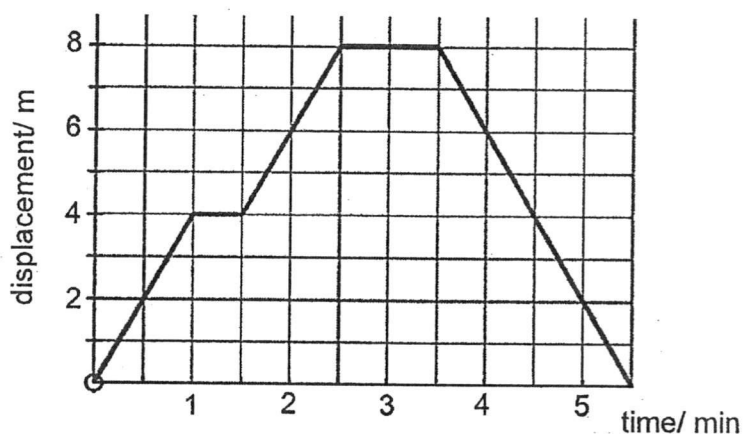

Which statement describes correctly the motion of the cyclist in the stated time interval?

- A. 0 to 1 min \rightarrow constant acceleration
B. 1 to 1.5 min \rightarrow at rest
C. 2.5 to 3.5 min \rightarrow constant speed
D. 3.5 to 5.5 min \rightarrow constant deceleration
3. Two forces act at right angles at a point O as shown below.

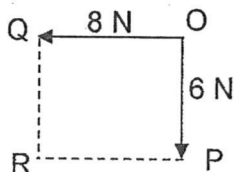

What is the magnitude of the resultant force and its direction?

	magnitude/ N	direction
A.	10	PQ
B.	10	OR
C.	14	PQ
D.	14	OR

4. A fully suited astronaut is able to jump 12 cm above ground on Earth. When he is on the Moon, he realised he can jump higher above ground. Which of the following best explains why?
- his weight is smaller on the Moon
 - his weight is the same on the Moon
 - his mass is smaller on the Moon
 - his mass is the same on the Moon
5. A mechanical digger is used to remove soil from the ground, as shown below.

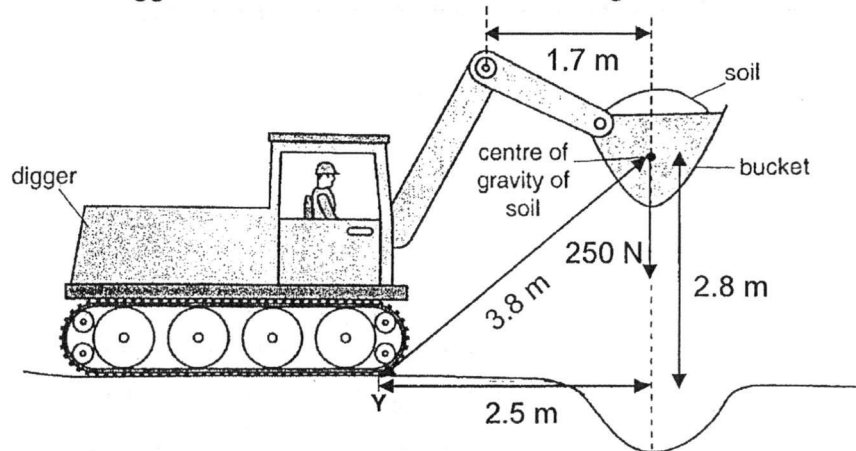

The bucket of soil weighs 250 N.

What is the moment about the pivot Y due to the weight of the bucket of soil?

- 425 Nm
 - 625 Nm
 - 700 Nm
 - 950 Nm
6. A 500 N block is placed on the table in the position shown.

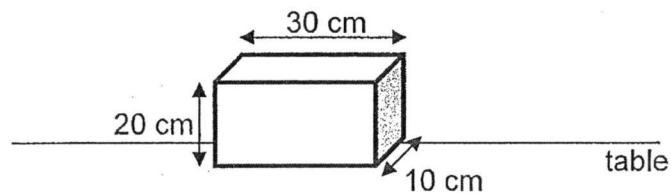

What is the pressure which the block exerts on the table?

- 0.08 N/cm^2
- 0.83 N/cm^2
- 1.67 N/cm^2
- 2.50 N/cm^2

7. A car brakes to a stop in front of a traffic light along a level road. What is the correct change in energy involved during the braking?
- A. Kinetic energy is changed to heat and sound energy.
 - B. Gravitational potential energy is changed to kinetic energy.
 - C. Heat is changed to kinetic energy.
 - D. Kinetic energy is changed to gravitational potential energy.
8. An electric kettle has a power rating of 1600 W. What is the amount of electrical energy over a period of 1.5 minutes?
- A. 1.1 kJ
 - B. 2.4 kJ
 - C. 144 kJ
 - D. 177 kJ
9. Some thermal flasks are designed with a layer of vacuum between the exterior and interior walls. What is the purpose of the vacuum layer?
- A. to reduce heat transfer via conduction and convection
 - B. to increase heat transfer via radiation
 - C. to reduce heat transfer via radiation
 - D. to increase heat transfer via conduction and convection
10. Which of the following statements is true about evaporation?
- A. It occurs at any temperature.
 - B. It takes place throughout the whole liquid body.
 - C. It occurs only at the boiling point of the liquid.
 - D. It warms up the liquid.

11. The diagram shows a ray of light changing its direction when it hits on the plane mirror.

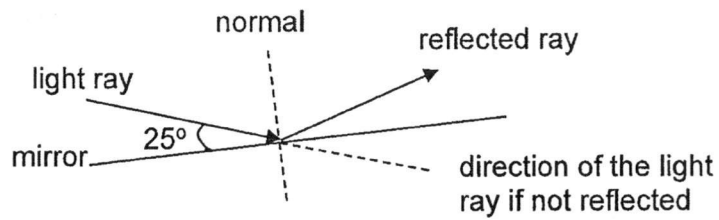

What is the change in the direction of the ray?

- A. 25° .
 B. 50° .
 C. 65° .
 D. 130°
12. A ray of light changes direction when it passes from air into the water

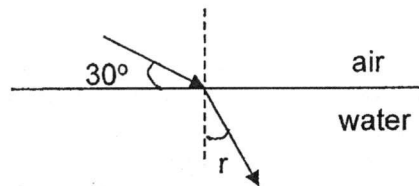

If the refractive index of the water is known to be 1.32, what is the angle of refraction, r ?

- A. 15° .
 B. 30° .
 C. 41° .
 D. 60°
13. An object is placed in front of a converging lens with a focal length of 6 cm. If the image produced has the same size as the object, how far is the object away from the lens?
- A. 12 cm
 B. 10 cm
 C. 6 cm
 D. 4 cm

14. A wave moving at 2.5 m/s covers a distance of 4.8 m with 5 wavefronts.

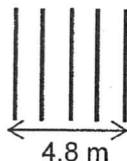

What is the wavelength?

- A. 0.50 m
 B. 0.96 m
 C. 1.20 m
 D. 1.92 m
15. The diagram shows a sound wave for a note emitted by the piano.

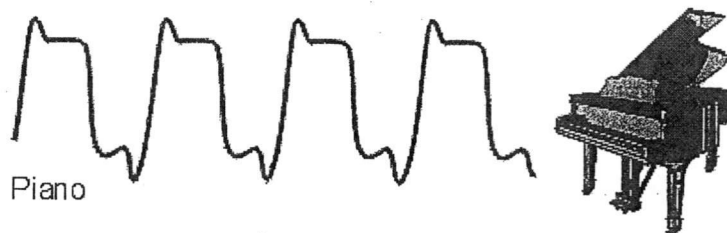

Another note of a higher pitch is played.
 How will the sound wave change over the same period of time?

- A. There will be more waves formed.
 B. The peaks of the waves will be higher.
 C. There will be less waves formed.
 D. The peaks of the waves will be lower.
16. Which of the following diagrams show the electric field pattern between two charged spheres?

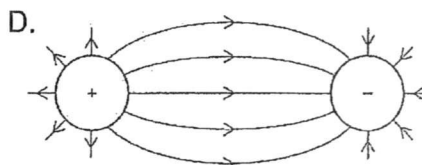
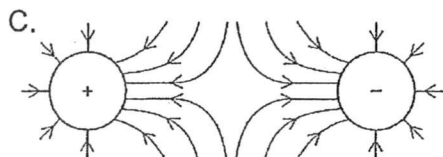
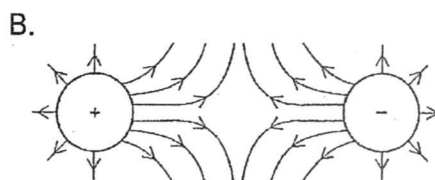
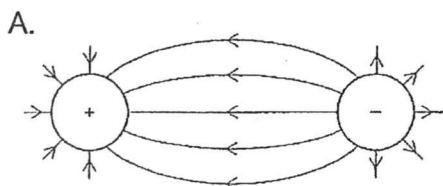

17. A wire of length 1.0 m and a cross-sectional area of $1.0 \times 10^{-6} \text{ m}^2$ has a resistance of $2.0 \ \Omega$. Another wire of the same material has a length of 2.0 m and a cross-sectional area of $1.5 \times 10^{-6} \text{ m}^2$. What is the resistance of the longer wire?
- A. $1.50 \ \Omega$
 B. $2.00 \ \Omega$
 C. $2.67 \ \Omega$
 D. $3.00 \ \Omega$
18. The diagram shows a 6.0 V battery connected to two resistors in parallel.

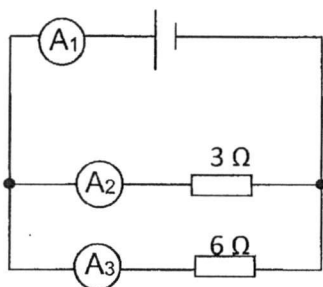

Which row shows the correct readings in the three ammeters?

	A_1 / A	A_2 / A	A_3 / A
A.	1.0	1.0	2.0
B.	1.0	2.0	1.0
C.	3.0	2.0	1.0
D.	3.0	1.0	2.0

19. The diagram shows the magnetic field pattern between two magnets. At which point is the magnetic field strength the weakest?

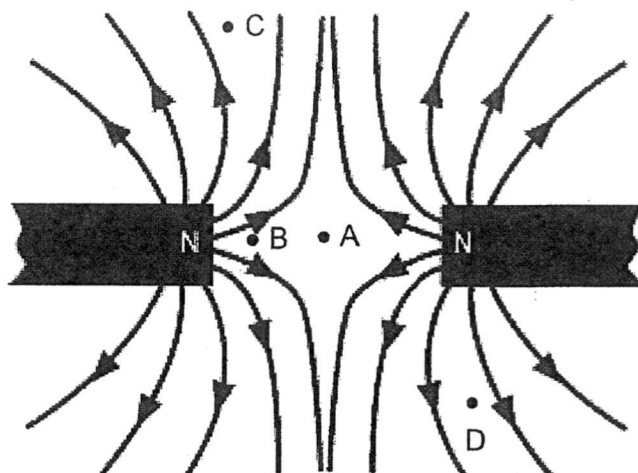

20. The diagram shows a current-carrying wire placed vertically between two magnets.

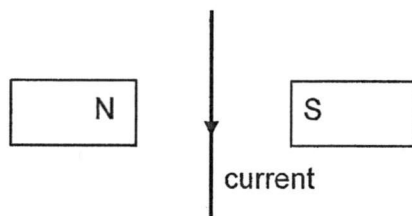

What is the direction of the force on the wire caused by the magnets?

- A. out of the page
- B. into the page
- C. to the left
- D. to the right



YUYING SECONDARY SCHOOL
PRELIMINARY EXAMINATION
 Secondary 4 Express & 5 Normal(Academic)

NAME

CLASS

REG. NO

SCIENCE**5076/2, 5077/2**

Physics

23 August 2017**1 hour 15 minutes****Setter: Mr Jameson Kang**

Candidates answer on the Question Paper.
 No Additional Materials are required.

READ THESE INSTRUCTIONS FIRST

Write your name, class and register number on all the work you hand in.
 Write in dark blue or black pen on both sides of the paper.
 You may use a soft pencil for any diagrams, graphs, tables or rough working.
 Do not use staples, paper clips, highlighters, glue or correction fluid.

Section A

Answer **all** questions in the spaces provided on the Question Paper.

Section B

Answer any **two** questions.

Write your answers in the spaces provided on the Question Paper.

The use of an approved calculator is expected, where appropriate.

The number of marks is given in brackets [] at the end of each question or part question.

For Examiner's Use	
Total	65

Section A

Answer **all** the questions in this section in the spaces provided.
The total mark for this section is 45.

1. Write down the measurements for the following instruments:

a) vernier caliper

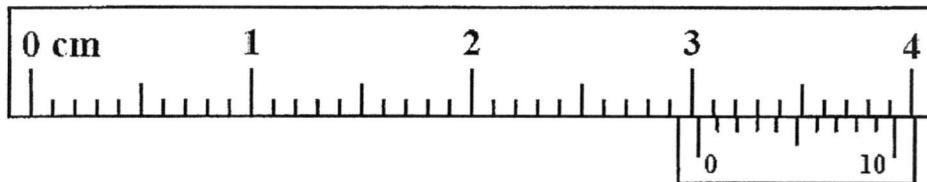

Reading: _____ cm [1]

b) micrometer screw gauge

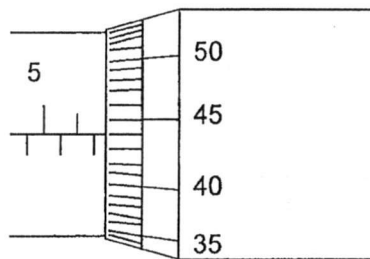

Reading: _____ mm [1]

2. Fig 2.1 shows two horizontal forces acting on an object. The mass of the object is 1.5 kg.

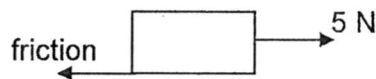

Fig 2.1

- a) If the object is accelerating at 0.5 ms^{-2} , what is the magnitude of the friction?

friction =N [2]

- b) After some time, the applied force is reduced to the same magnitude as the friction.
Describe the motion of the object.

.....
 [1]

3. A vertical uniform cylinder contains a volume of liquid, as shown in Fig 3.1.

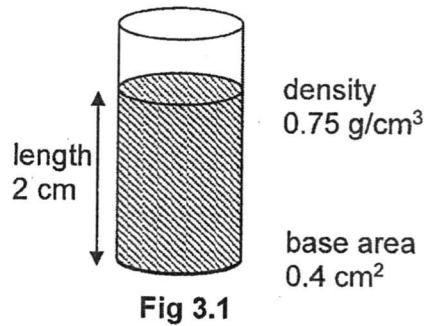

The cross-sectional area of the cylinder is 0.4 cm^2 .
 The vertical length of the liquid is 2 cm .
 The density of the liquid is 0.75 g/cm^3 .

- a) What is the mass of the liquid in the cylinder?

mass = g [2]

- b) What is the weight of the liquid in the cylinder? (Assume $g = 10 \text{ N/kg}$)

weight = N [2]

- c) What is the pressure which the liquid exerts on the base of the cylinder?

pressure = N/cm² [2]

4. A toy car rolls down a smooth slope as shown in Fig 4.1.

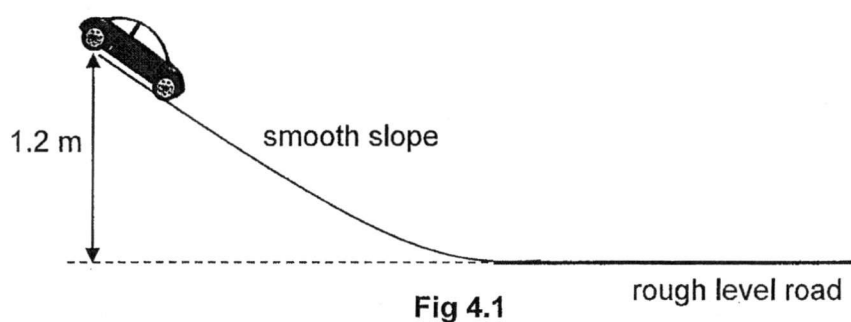

The initial height of the slope is 1.2 m.
 The mass of the toy car is 600 g.
 The gravitational field strength is 10 N/kg.

- a) What is the initial gravitational potential energy of the toy car?

gravitational potential energy = J [2]

- b) What is the speed of the toy car when it hits the bottom of the slope?

speed = m/s [2]

- c) If the friction along the level road is 3 N, what is the distance moved by the toy car before it stops?

distance = m [2]

5. The following figure shows the variations of a sound wave over time.

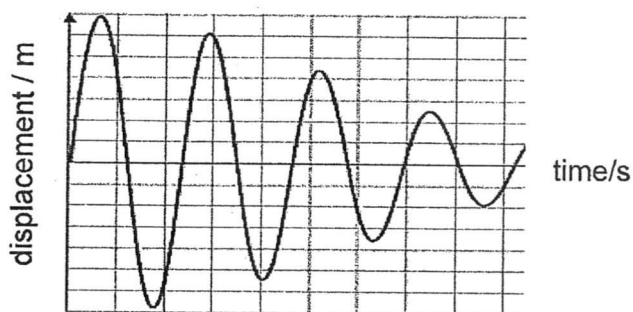

Fig 5.1

- a) Comment on the volume of the sound and explain your answer.

.....

 [2]

- b) The frequency of the sound is 60 Hz.
 What is the wavelength of the sound if its speed is 330 m/s?

wavelength = m [2]

6. A light ray is travelling from a glass into air as shown in Fig. 6.1.

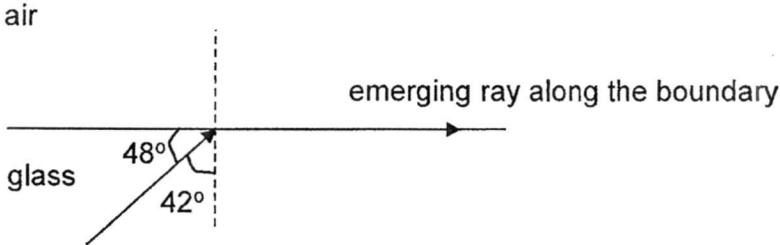

Fig. 6.1

a) Explain what is *critical angle*.

.....

 [2]

b) State the critical angle of the glass.

Critical angle =° [1]

c) What is the refractive index of the glass?

refractive index = [2]

d) State the conditions required for total internal reflection to occur.

.....

 [2]

7. An object is placed 5.0 cm in front of a thin converging lens as shown in Fig. 7.1. The image formed is real, inverted and the same size as the object.

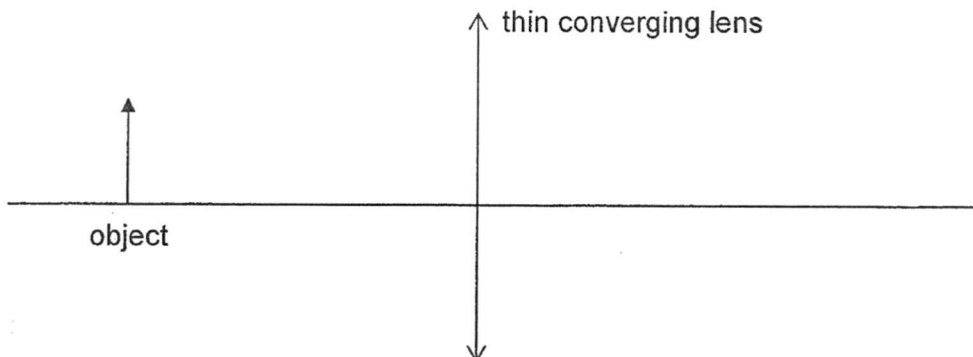

Fig 7.1 (drawn to scale)

- a) On Fig 7.1, draw a ray diagram to determine the focal length of the lens.

focal length = cm [3]

- b) Describe the change in the focused image as the object is moved closer to the lens by 1 cm.

..... [1]

- c) Describe fully the characteristics of the image produced when the object is placed at 2 cm away from the lens.

..... [1]

8. Electromagnetic waves has many applications in daily lives.

- a) State an application for each of the waves listed below.

EM waves	Application
ultraviolet ray	
gamma ray	
infrared radiation	
radiowave	

[2]

- b) Arrange the waves listed in (a) in order of increasing frequency.

.....

..... [1]

9. A girl stood in front of a tall building and fired a pistol. A boy standing 350 m away from the girl heard two bangs 1 s apart.

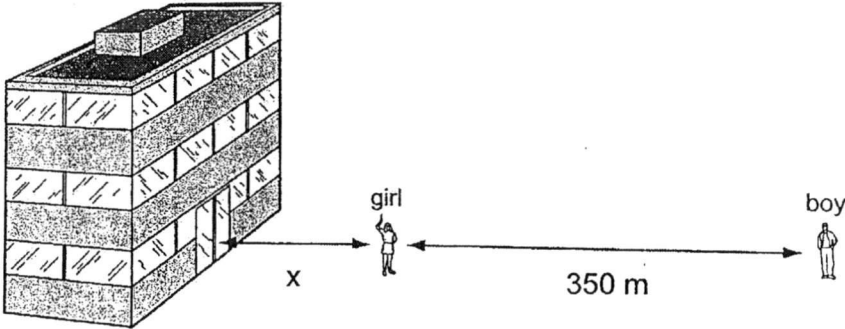

Fig 9.1

- a) State two ways in which sound waves are different from light waves.

.....
.....
.....
..... [2]

- b) If the speed of sound in air is 330 m/s, how far is the girl away from the building?

distance = m [2]

10. Three resistors are arranged in parallel as shown in the circuit in Fig. 10.1.

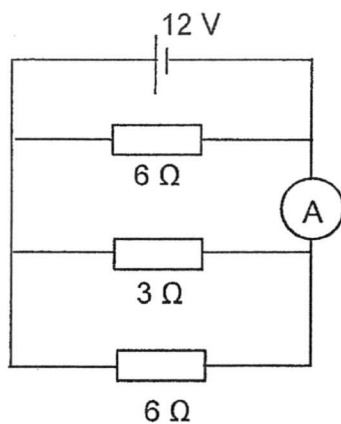

Fig 10.1

- a) What is the total resistance of the circuit?

total resistance = Ω [2]

- b) What is the total circuit current?

total current = A [2]

- c) What is the reading in the ammeter?

ammeter reading = A [1]

Section B

Answer **any two** questions in this section in the spaces provided.

The total mark for this section is 20.

11. Fig. 11.1 shows the speed-time graph of an object falling through the air from rest until it hits the ground. The mass of the object is 0.8 kg.

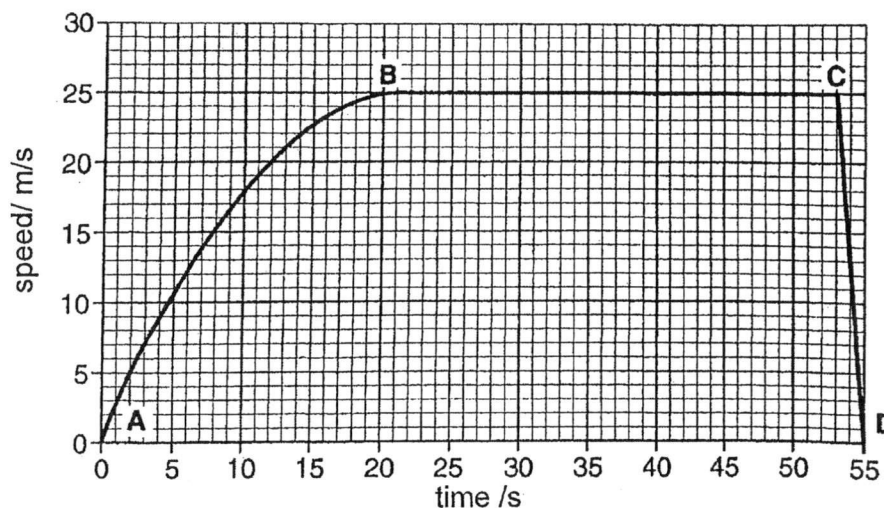

Fig. 11.1

- a) State the magnitude of the acceleration of the object between points B & C.

acceleration = ms^{-2} [1]

- b) Describe the motion of the object between points A and B.

.....
 [1]

- c) Use the weight of the object and the air resistance to explain the motion of the object between points A and B.

.....

 [3]

- d) State the magnitude of the air resistance experienced by the object between points B and C. (Assume $g = 10 \text{ N/kg}$)

air resistance = N [1]

- e) What is the distance moved by the object from 20 s to 55 s?

distance = m [2]

- f) What is the acceleration of the object between points C and D?

acceleration = ms^{-2} [2]

12. Fig. 12.1 shows an electric kettle connected to the 230 V mains supply.

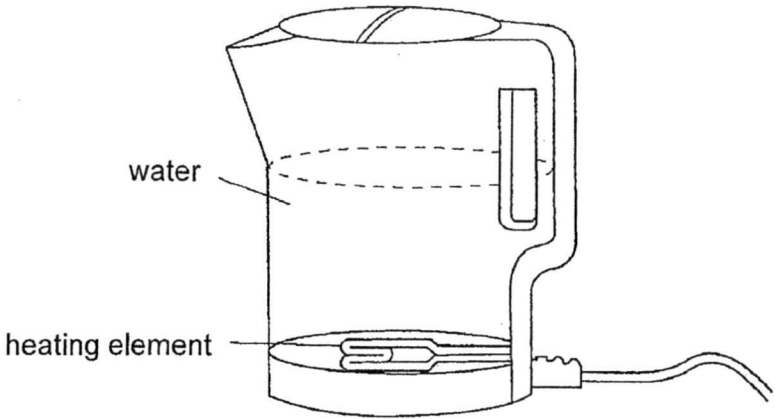

Fig 12.1

a) The water is heated up via convection in the kettle.
Explain how the convection current is formed within the water.

.....

.....

.....

.....

.....

..... [2]

b) The kettle body is made of white coloured plastic.
Explain how this design helps to reduce heat loss to the surroundings.

.....

.....

.....

.....

..... [2]

- c) The power rating of the kettle is 1500 W.
What is the current drawn by the kettle during normal operating conditions?

current =A [2]

- d) The kettle is designed with a fuse as a safety device.
Explain how a fuse works and suggest if a fuse rating of 6 A or 8 A is more suitable for the kettle.

.....
.....
.....
.....
..... [2]

- e) The cost of electrical energy is 25 cents per kWh.
What is the cost of operating the kettle per day if it is being used for 20 minutes on average in one day?

cost =cents [2]

- e) If the permanent magnet is replaced by an iron rod, explain if a sound wave can be generated using a similar set-up in (d).

.....

.....

.....

.....

.....

.....

..... [3]

END OF PAPER

Marking Scheme for 4E5N Prelim 2017

Paper 1

1	C	6	C	11	B	16	D
2	B	7	A	12	C	17	C
3	B	8	C	13	A	18	C
4	A	9	A	14	C	19	A
5	B	10	A	15	A	20	A

Paper 2

Section A

Qn	Answer	Remarks
1 a	3.03 cm	A1
1 b	6.94 mm	A1
2a	Applied force – friction = ma 5 – friction = 1.5 x 0.5 Friction = 4.25 N	M1 A1
2b	The object continues to move with constant speed.	A1
3a	Mass = density x volume = 0.75 x 0.4 x 2 = 0.6 g	M1 A1
3b	Weight = mass x g = 0.6/1000 x 10 = 0.006 N	Allows ecf M1 A1
3c	Pressure = force/ area = 0.006 / 0.4 = 0.015 N/ cm ²	Allows ecf M1 A1
4a	GPE = mgh = 600/1000 x 10 x 1.2 = 7.2 J	M1 A1
4b	KE = 7.2 0.5 x 0.6 x v ² = 7.2 v = 4.90 m/s	Allows ecf M1 A1
4c	Work done = KE Friction x distance = 7.2 3d = 7.2 d = 2.4 m	Allows ecf M1 A1
5a	The volume is getting softer over time. The amplitude of the wave is decreasing over time.	A1 A1
5b	v = f λ λ = 330 / 60 λ = 5.5 m	M1 A1
6a	The angle of incidence which produces an angle of refraction of 90 degree [1] when the light passes from a denser medium to a less dense medium [1].	A1 A1
6b	42 deg	A1

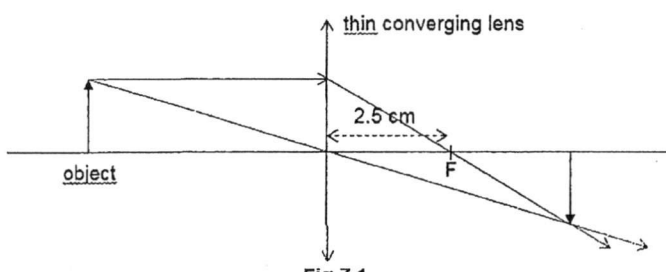
6c	$n = 1 / \sin c$ $= 1.49$	M1 A1
6d	Light must be travelling from a denser medium to a less dense medium. Angle of incidence must be greater than the critical angle.	A1 A1
7a	 <p style="text-align: center;">Fig 7.1</p> <p>Image is at 5 cm away from lens. Two light rays to complete the ray diagram. (1m awarded to each light ray drawn correctly. -0.5m overall if no arrows for light rays)</p> <p>$f = 2.5 \text{ cm}$ (allows for 2.6 cm)</p>	M2 (awarded regardless of focal length accuracy) -0.5m if no arrows for the light rays A1
7b	The focused image becomes larger.	A1
7c	Virtual, upright, magnified	A1
8a	Ultraviolet ray – sunbed, sterilisation Gamma ray – medical treatment Infrared – remote controller, intruder alarm Radiowave – television/ radio communication	Each correct application is 0.5 m
8b	Radiowave, infrared radiation, ultraviolet ray, gamma ray	A1
9a	Sound cannot travel through vacuum while light can. Sound is a longitudinal wave while light is transverse wave.	A1 A1
9b	1 st bang, distance = 350 m 2 nd bang, distance = 350 m + 2x time difference = 1s, speed = 330 m/s difference in distance = 330 m $2x = 330$ $x = 165 \text{ m}$	M1 A1
10a	Total $R = (1/3 + 1/6 + 1/6)^{-1}$ $= 1.5 \Omega$	M1 A1
10b	Total current = V / R $= 12/1.5$ $= 8 \text{ A}$ Can also use ohm's law to find individual branch current and sum up.	M1 A1
10c	Reading = $4 \text{ A} + 2 \text{ A} = 6 \text{ A}$	A1

P2 Section B

11a	0 ms^{-2}	A1
11b	The object is falling with decreasing acceleration.	A1
11c	As speed increases, air resistance also increases but weight remains unchanged.	A1
	The resultant force decreases.	A1
	Using $F = ma$, the acceleration also decreases.	A1
11d	8 N	A1
11e	Distance = area under the graph	M1
	= $0.5 \times (35+33) \times 25$	A1
	= 850 m	
11f	$a = (v-u) / t$	
	= $(0 - 25) / (55 - 53)$	M1
	= -12.5 ms^{-2}	A1
12a	Water at the bottom is heated up by the heating element. The less dense hot water [0.5] rises up [0.5] while the denser cool water [0.5] at the top moves down [0.5]. The process continues and form a convection current.	
12b	White colour is a poor emitter of heat so it reduces heat loss via radiation.	A1
	Plastic is a poor conductor of heat so it reduces heat loss via conduction.	A1
12c	$P = VI$	
	$1500 = 230 I$	M1
	$I = 6.5 \text{ A}$	A1
12d	When the current drawn is larger than the fuse rating, the fuse will melt and break the circuit.	A1
	8 A fuse is more suitable.	A1
12e	Cost = kWh x rate	
	= $1.5 \text{ kW} \times 20/60 \times 25 \text{ cents}$	M1
	= 12.5 cents	A1
13a	The iron core will be magnetised	A1
13b	P: North, Q: South	A1
13c	The magnet will be repelled/ move away from the iron core	A1
13d	As the current changes direction, the polarities of the iron core also change.	A1
	It will attract and repel the permanent magnet continuously.	A1
	The cardboard will vibrate left and right continuously.	A1
	This generates a series of compression and rarefaction to produce sound.	A1
13e	The iron rod will be induced to have an opposite pole from the iron core.	A1
	It will always be attracted to the iron core.	A1
	No vibration of the cardboard to produce sound.	A1

