



Geylang Methodist School (Secondary) Preliminary Examination 2018

SCIENCE (CHEMISTRY/BIOLOGY)
Paper 1

5078/1
Sec 4E/5N

Additional materials : Optical Answer sheet (OAS)

1 hour

Setter : Iskandar
Ms Lam Yuit Kwai

18 Aug 2018

READ THESE INSTRUCTIONS FIRST

Write in soft pencil.

Do not use staples, paper clips, highlighters, glue or correction fluid on the Optical Answer Sheet.

Write your name, class and index number on the Optical Answer Sheet provided.

There are **forty** questions in this paper. Answer all the questions. For each question, there are four possible answers, **A, B, C** and **D**.

Choose the **one** you consider correct and record your choice in **soft pencil** on the separate answer sheet.

Read the instructions on the answer sheet very carefully.

Each correct answer will score one mark. No mark will be deducted for a wrong answer.

Any rough work should be done in this booklet.

A copy of the periodic table is printed on page 24.

Section A

21 The diagram shows a section through a leaf.

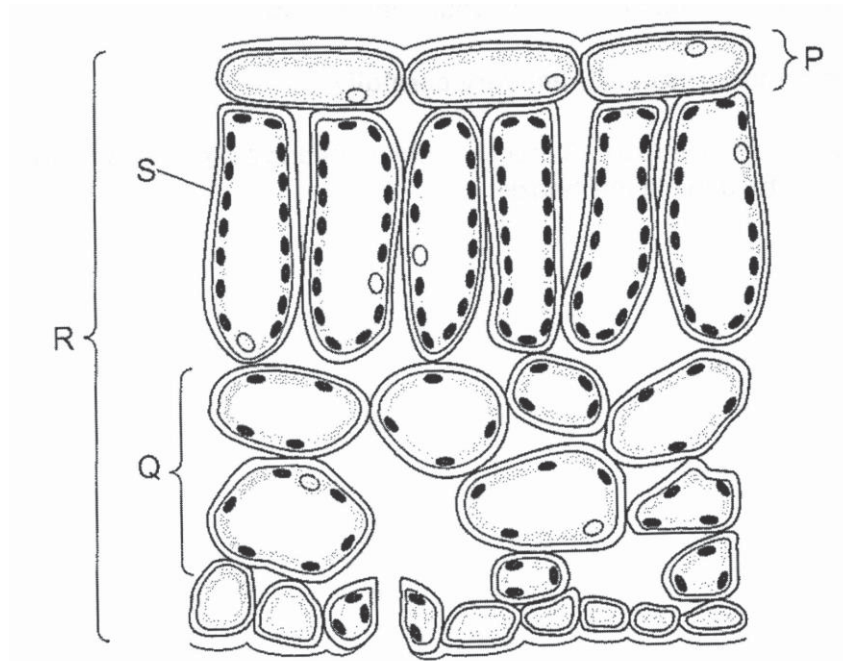

Which of the following correctly identifies an organ and a tissue?

	organ	tissue
A	P	R
B	Q	S
C	R	P
D	S	Q

- 22 The diagram shows some chemical molecules found in the human body and how they join to form larger molecules.

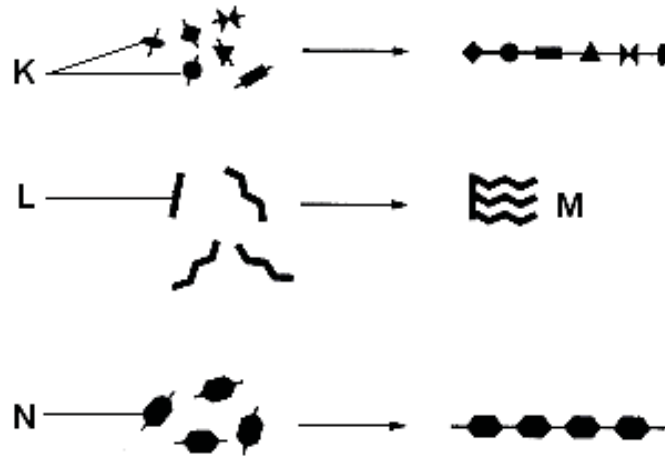

Which of the following correctly identifies molecules **K**, **L**, **M** and **N**?

	K	L	M	N
A	amino acid	glycerol	fat	glucose
B	protein	glycerol	fatty acid	starch
C	maltose	fat	glycerol	cellulose
D	fatty acid	amino acid	starch	glucose

- 23 The diagram illustrates the 'lock and key' hypothesis of enzyme action.

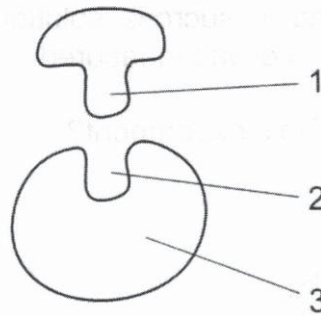

Which of the following correctly identifies the enzyme, the active site and the substrate?

	enzyme	active site	substrate
A	1	2	3
B	1	3	2
C	3	1	2
D	3	2	1

- 24 Pepsin is an enzyme that is active in the human stomach.

Which graph shows how the rate of reaction of pepsin is affected by pH?

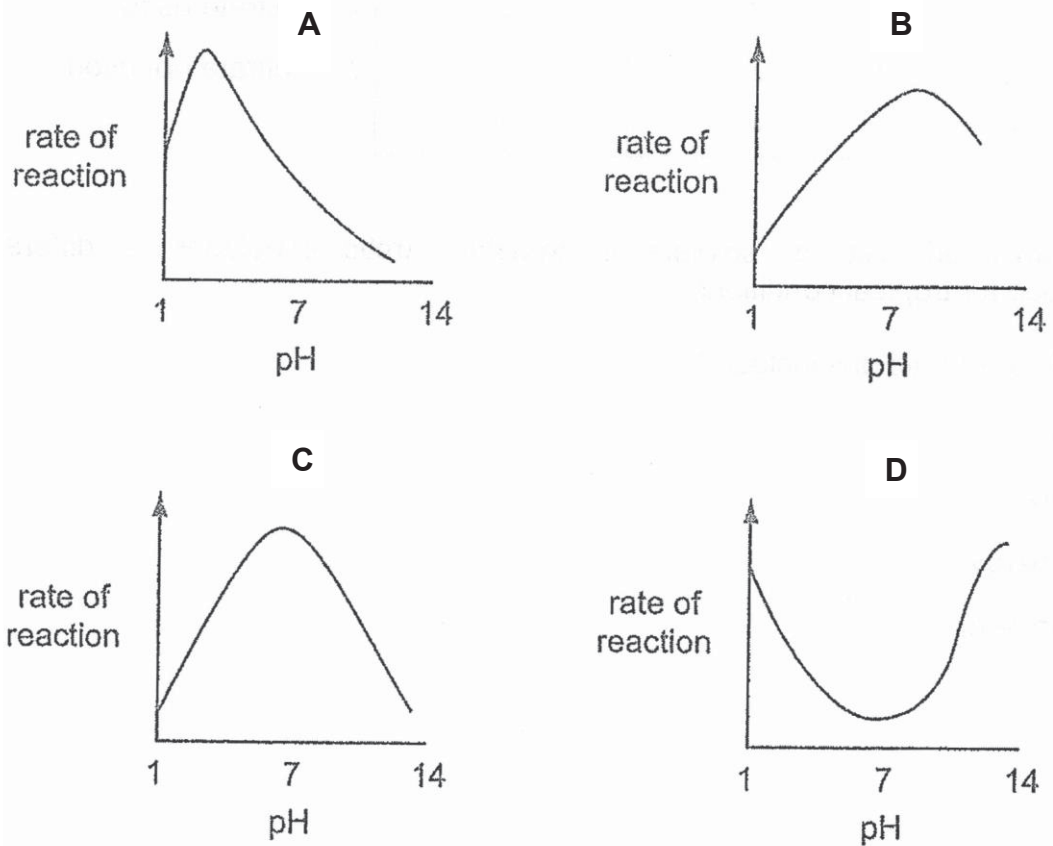

- 25 Which bar chart represents the amount of starch digested in the mouth, stomach and ileum of a human?

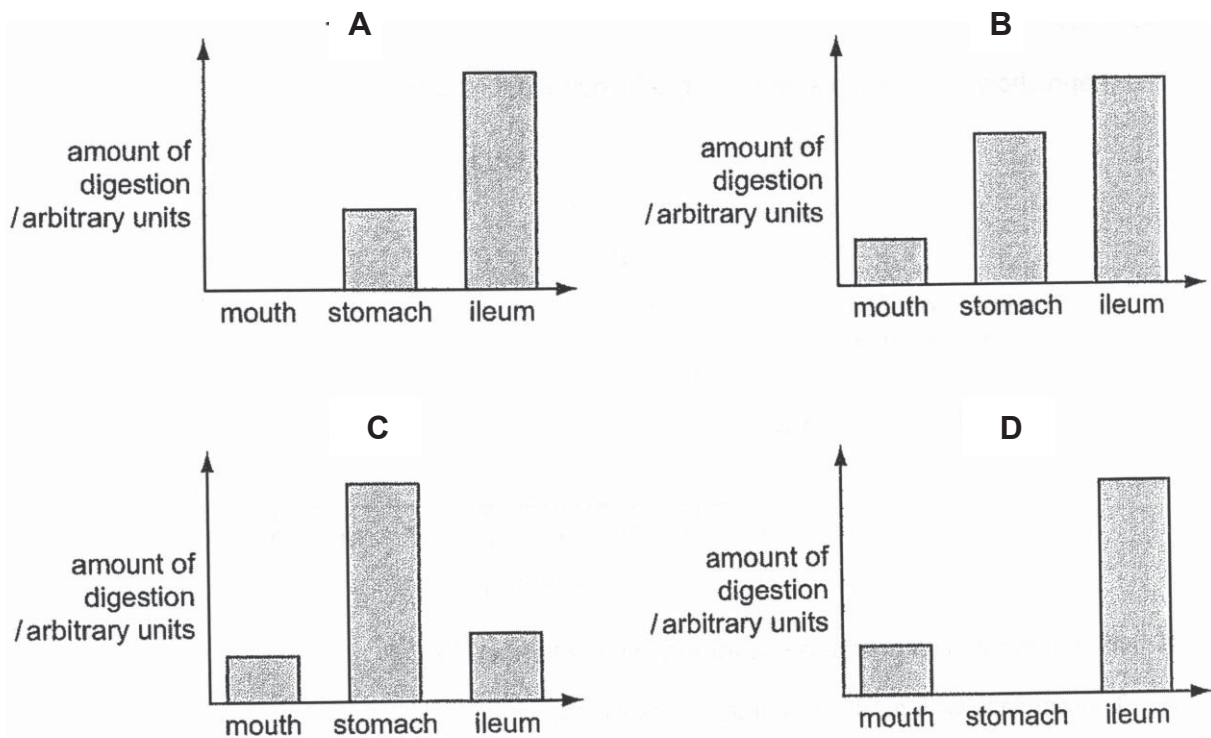

- 26 The diagram shows part of the human alimentary canal.

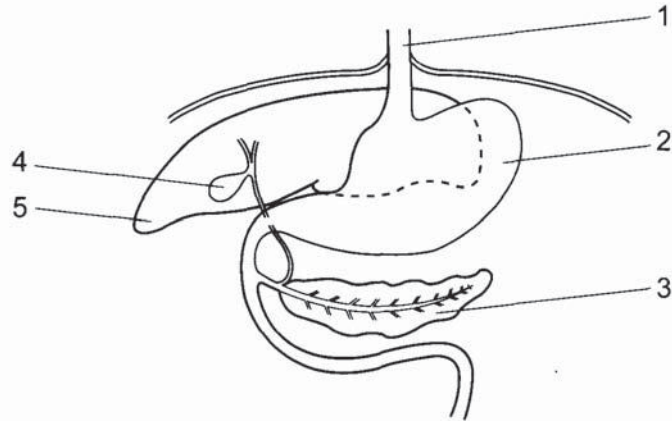

Which two structures produce substances involved in the digestion of fat?

- A** 1 and 4
B 3 and 5
C 2 and 3
D 4 and 5
- 27 A plant is kept in the dark for two days.

A leaf is used in an experiment to investigate the effect of two factors on photosynthesis, as shown in the diagram.

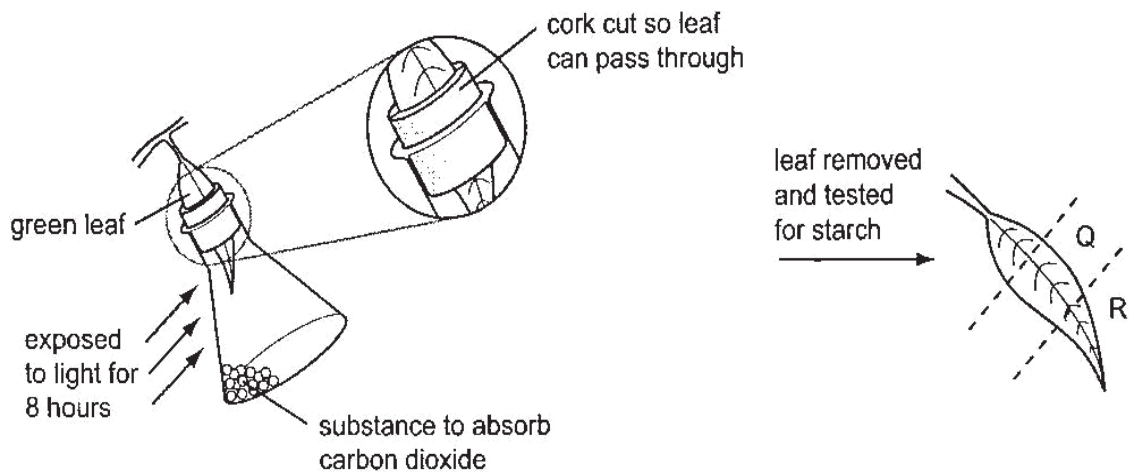

What are the colours of **Q** and **R**, when the leaf is tested for starch?

	Q	R
A	brown	brown
B	brown	blue-black
C	blue-black	brown
D	blue-black	blue-black

- 28 The diagram shows the right-hand side of the human heart when the ventricle is relaxed.

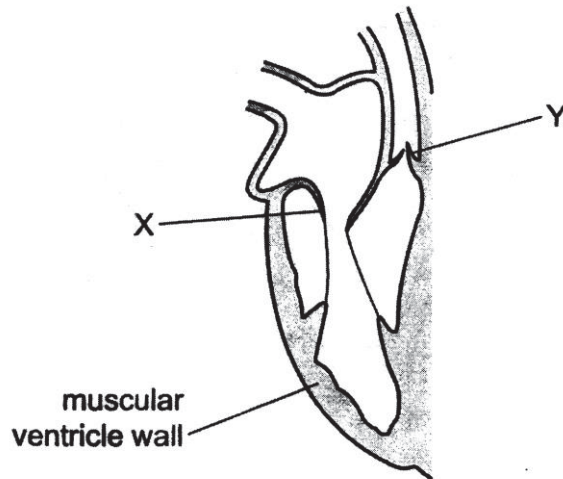

Which row correctly describes the position of the valves X and Y when the ventricle contracts?

	valve at X	valve at Y
A	closed	closed
B	closed	open
C	open	closed
D	open	open

- 29 A shoot is placed in a beaker of red coloured water for 3 hours.
The diagrams show transverse sections of a leaf and stem of the shoot.

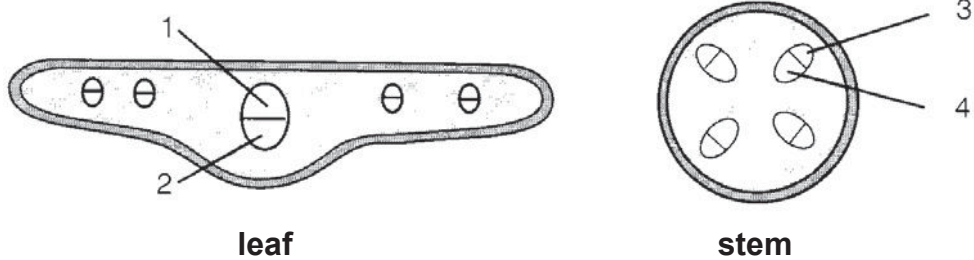

Which regions, 1 – 4, will be stained red after three hours?

- A** 1 and 2
B 2 and 4
C 1 and 4
D 2 and 3

30 An experiment is set up as shown.

Test-tubes 1 and 2 contain limewater. Limewater is a clear solution that turns cloudy in the presence of carbon dioxide. Air is pumped through the apparatus.

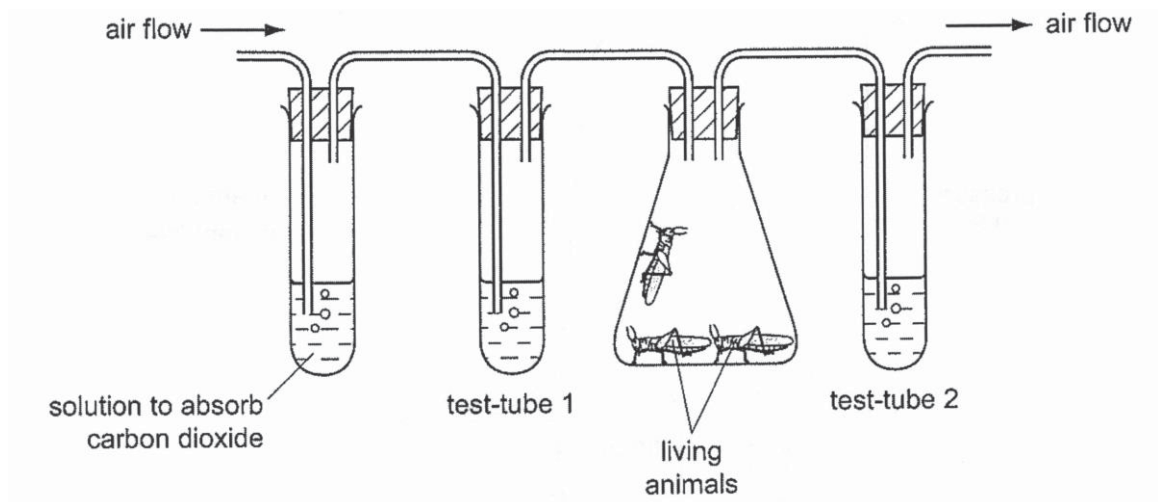

What is the appearance of the limewater in test-tubes 1 and 2 after a period of ten minutes?

	test-tube 1	test-tube 2
A	clear	clear
B	clear	cloudy
C	cloudy	clear
D	cloudy	cloudy

31 The diagram shows a section through part of the eye.

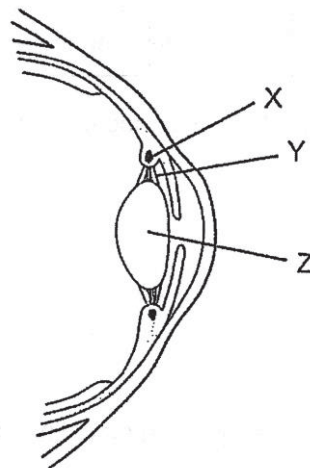

What happens to parts X, Y and Z when the eye focuses on a near object?

	X	Y	Z
A	contracts	tight	less convex
B	contracts	slack	more convex
C	relaxes	tight	less convex
D	relaxes	slack	more convex

32 The diagram shows a simple knee-jerk reflex.

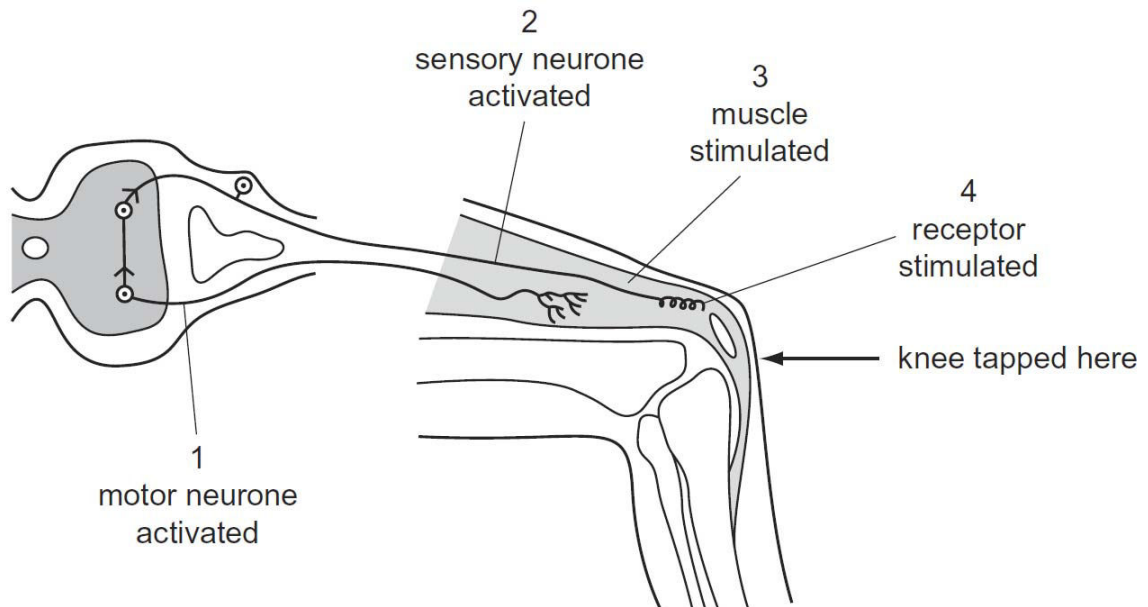

What is the correct order of events after the knee is tapped?

- A 1 → 2 → 3 → 4
- B 1 → 4 → 2 → 3
- C 4 → 2 → 1 → 3
- D 4 → 3 → 2 → 1

- 33 The graph shows changes in the glucose concentration in the blood of a person during two hours.

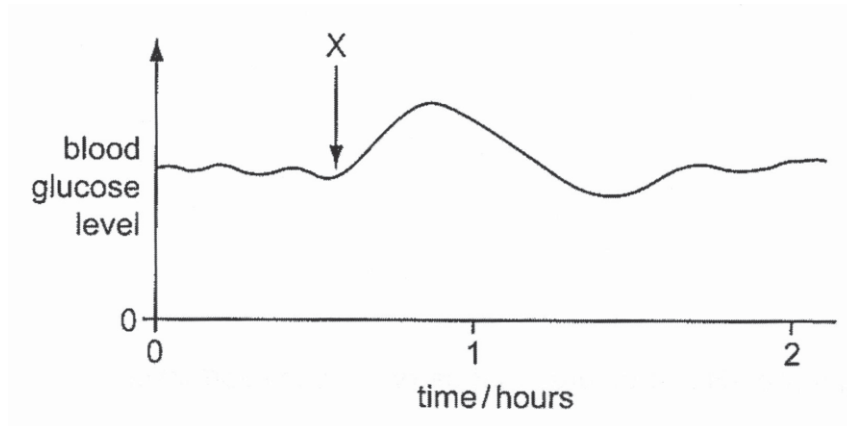

What explains the shape of the graph after X?

- A The person has eaten a jam sandwich.
 - B The person has had an insulin injection.
 - C The person is running a marathon.
 - D The person is suffering from a condition in which insulin is lacking.
- 34 The diagram shows the stigma, style and ovary of a flower.

Where does fertilisation take place?

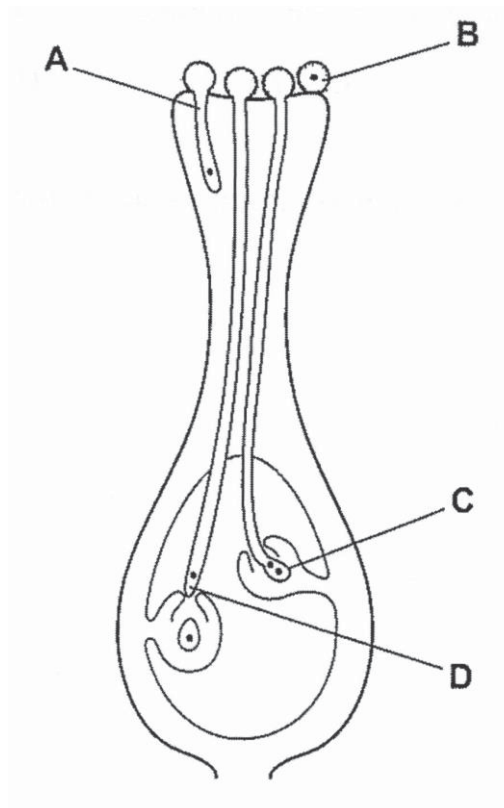

- 35 The diagram shows a plant that is producing small plantlets.

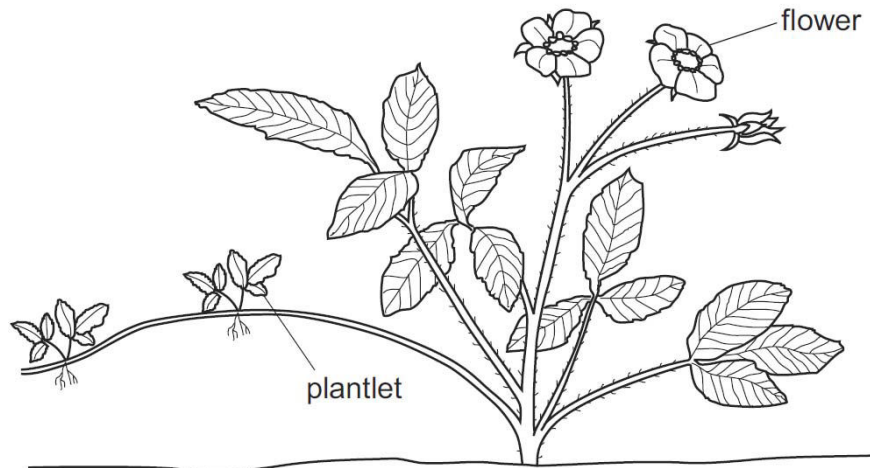

Which statement about the plantlets is correct?

- A They are genetically identical to the parent plant.
 - B They are genetically different from the parent plant.
 - C They are produced by seeds formed in the fruit while attached to the plant.
 - D They are produced as a result of the fusion of nuclei.
- 36 The diagram shows part of the human male reproductive system.

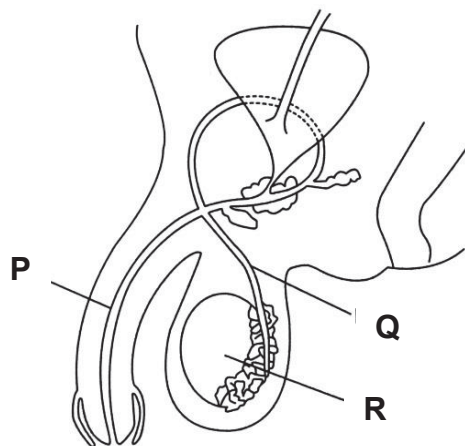

What are the structures **P**, **Q** and **R**?

	P	Q	R
A	sperm duct	urethra	testis
B	sperm duct	testis	urethra
C	urethra	testis	sperm duct
D	urethra	sperm duct	testis

37 A Down's Syndrome child is born.

Which diagram shows the correct number of chromosomes in the cells of the parents, in their gametes and in the cells of their child with Down's Syndrome?

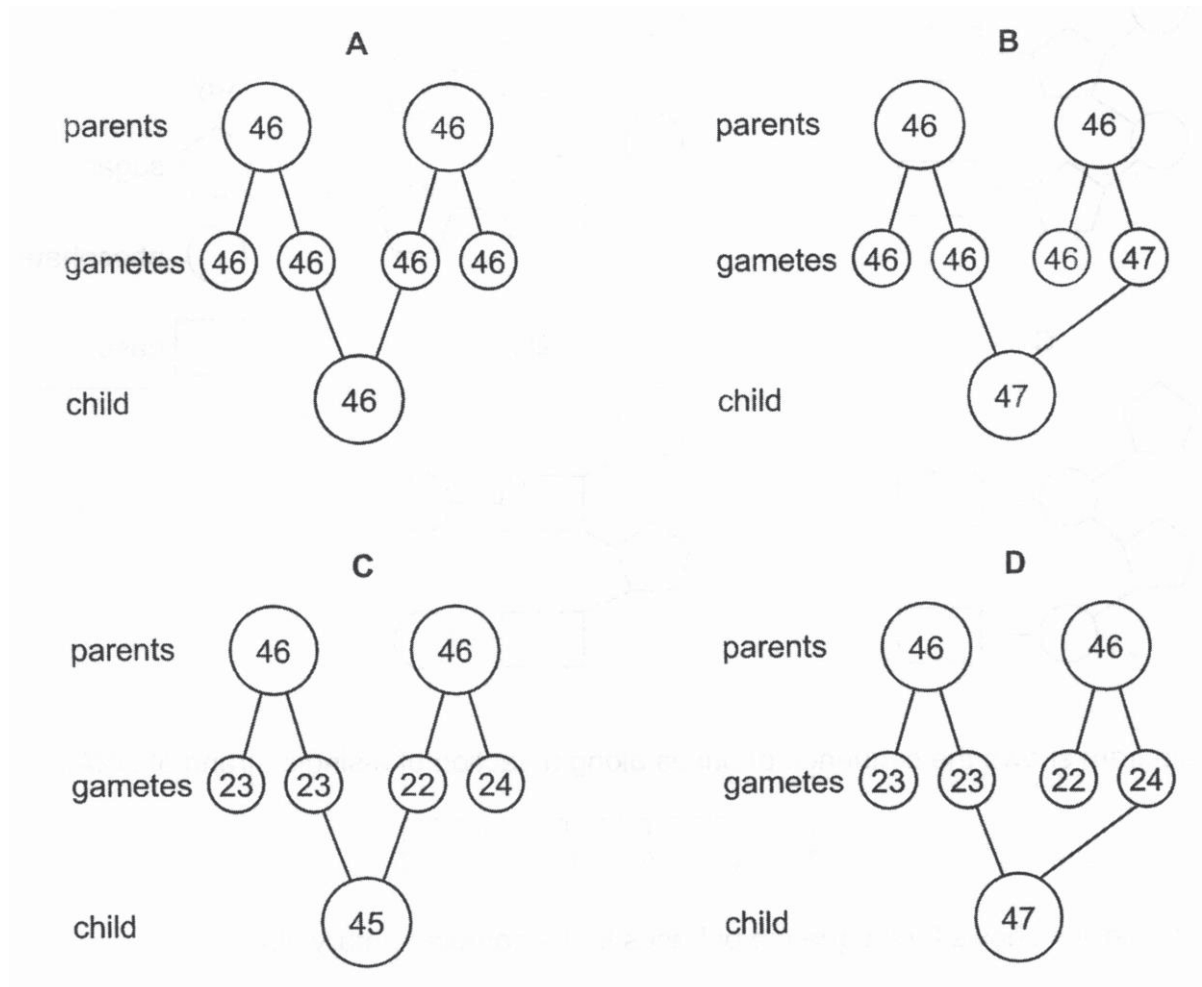

38 In mice, the allele for long fur is dominant and the allele for short fur is recessive.

Several heterozygous mice with long fur were mated with several mice with short fur. For every 100 offspring, how many should be predicted to have short fur?

- A 25
- B 50
- C 75
- D 100



Geylang Methodist School (Secondary) Preliminary Examination 2018

Candidate Name

Class Index Number

SCIENCE

5078/04

Paper 4 Biology

Sec 4 Express
Sec 5 Normal (A)

Additional materials : Writing paper

1 hour 15 minutes

Setter : Ms Lam Yuit Kwai

20 Aug 2018

READ THESE INSTRUCTIONS FIRST

Write your name, index number and class on all the work you hand in.
Write in dark blue or black pen on both sides of the paper.
Do not use staples, paper clips, highlighters, glue or correction fluid.

Section A (45 marks)

Answer **all** the questions.

Write your answers in the spaces provided on the question paper.

Section B (20 marks)

Answer any **two** questions.

Write your answers in the spaces provided on the question paper and the question no. you have attempted in the box on the right side of this page.

The number of marks is given in brackets [] at the end of each question or part question.

For Markers' Use	
Section A	45
Section B	
	10
	10
TOTAL	65

This question paper consists of **16** printed pages.

[Turn over

Section A

Answer **all** the questions in the spaces provided.

- 1 A student cut six pieces of potato and weighed each one. He placed each piece of potato in a different concentration of sugar solution for 60 minutes. He then re-weighed each piece of potato. He worked out the change in mass for each piece as a percentage of the original mass. His results are shown in Table 1.1.

Table 1.1

concentration of sugar solution / mol per dm ³	mass of potato / g		percentage change in mass / %
	start	finish	
0.20	8.42	9.18	+9.0
0.30	8.15	8.68	+6.5
0.40	8.30	8.48	+2.2
0.50	8.62	8.31	-3.6
0.60	8.38	7.83	-6.6
0.70	8.22	7.53	

- (a) Calculate the percentage change in mass for the sugar concentration of 0.70 mol per dm³.

percentage change in mass = _____ % [2]

- (b) On the grid provided on the next page, plot the graph of percentage change in mass against concentration of sugar solution. Use the results in **Table 1.1** and your answer to (a).

On your graph, use appropriate scales, label the axes and draw a line of best-fit. [4]

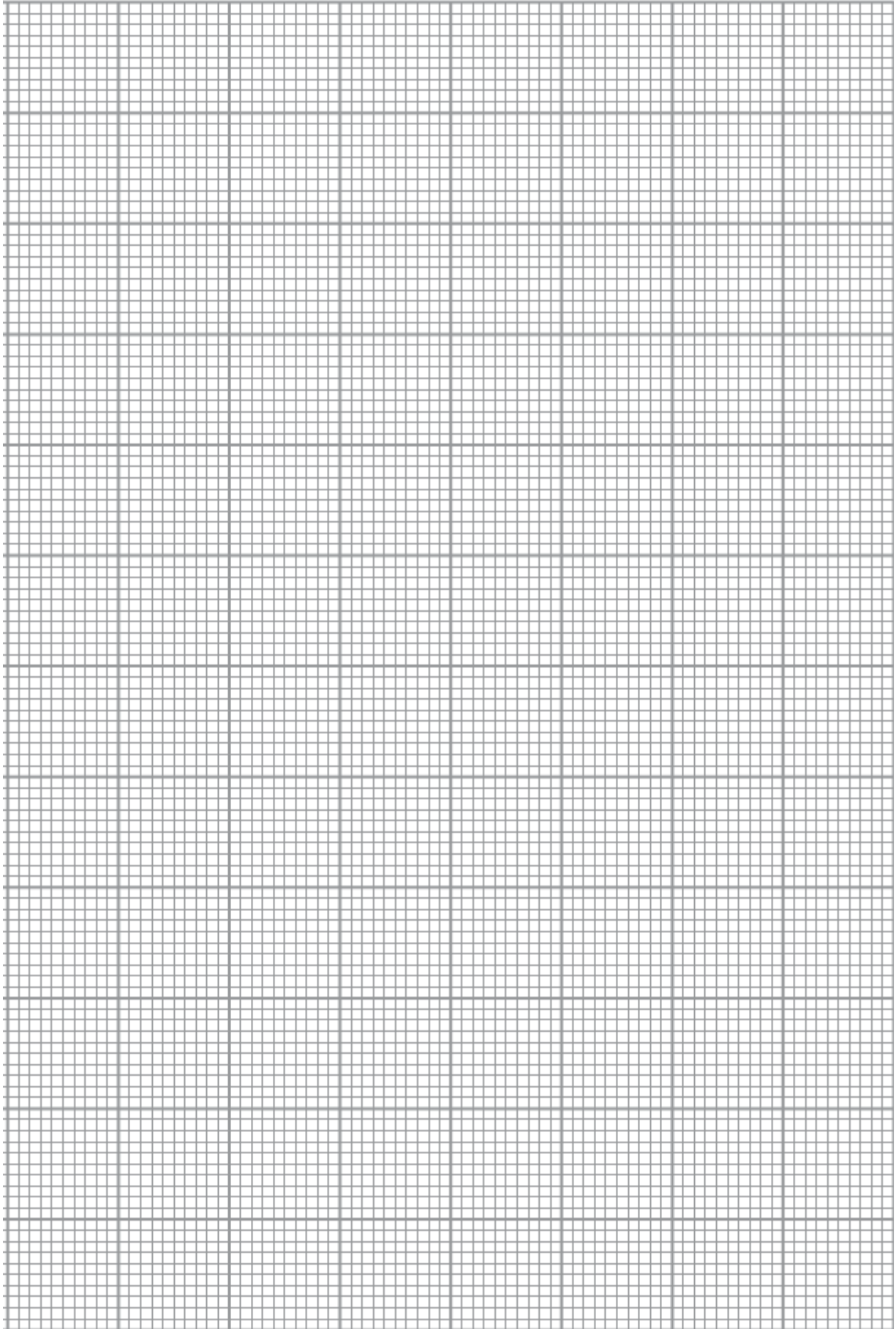

(c) (i) Use your graph to suggest a concentration for the cell sap in the potato.
_____ mol per dm³ [1]

(ii) Explain your answer to (c)(i).

_____ [2]

2 Fig. 2.1 shows the human respiratory system.

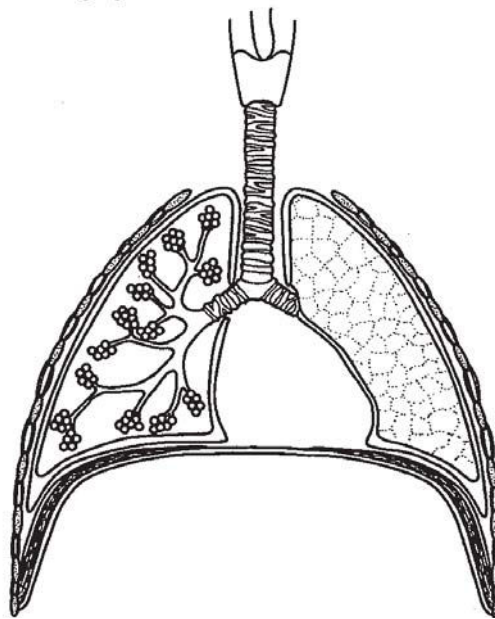

Fig. 2.1

(a) Add labels to the diagram to show the trachea, a bronchiole and some alveoli. [3]

- (b) At the exchange surface of the alveoli, oxygen travels from the air to the blood.

Explain how the structure of the alveoli aids the rapid transfer of oxygen at this surface.

[3]

- (c) Smoking cigarettes can have serious effects on health.

(i) Name **three** major toxic compounds of tobacco smoke.

1. _____
2. _____
3. _____

[3]

(ii) Suggest **two** ways that smoking cigarettes may affect the health of the lungs.

[2]

- 3 Fig. 3.1 and F3.2 show two frontal views of an eye under different lighting conditions.



Fig. 3.1

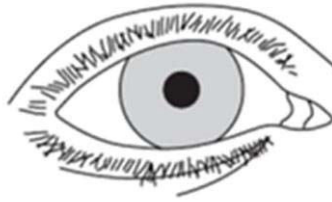

Fig. 3.2

- (a) On Fig. 3.1, use label lines to identify the following structures

- (i) iris [1]
- (ii) pupil [1]

- (b) Suggest how the change in the eye from Fig. 3.1 to Fig. 3.2 is brought about.

[3]

- 4 Haemochromatosis is an inherited disorder that results in an accumulation (build up) of iron in the liver. It is inherited as a recessive allele.

Fig. 4.1 shows how haemochromatosis was inherited in one family.

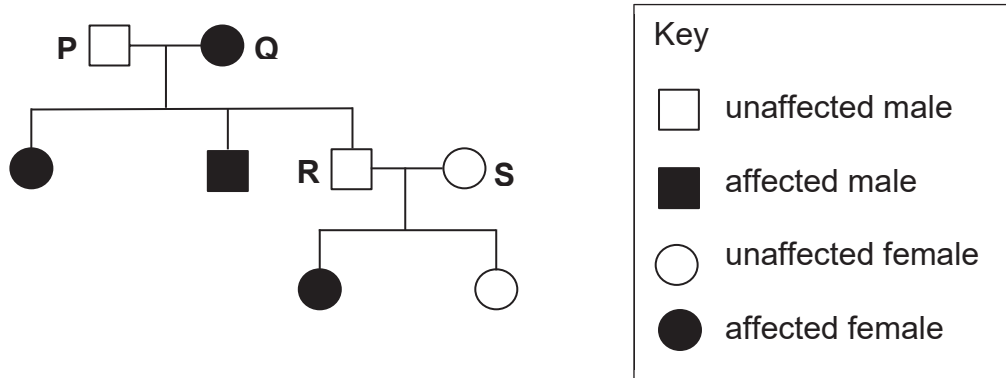

Fig. 4.1

In answers to this question, use **H** to represent the normal allele and **h** to represent the recessive allele.

- (a) (i) What is the genotype of parent **P**? _____ [1]
- (ii) What is the genotype of parent **Q**? _____ [1]
- (b) Parents **R** and **S** have a third child. What is the chance that this child has haemochromatosis?

Use the Punnett square to work out your answer.

	father R	
mother S		

Chance of the child having the disorder = _____ [3]

5 Fig. 5.1 below shows a section of a DNA molecule.

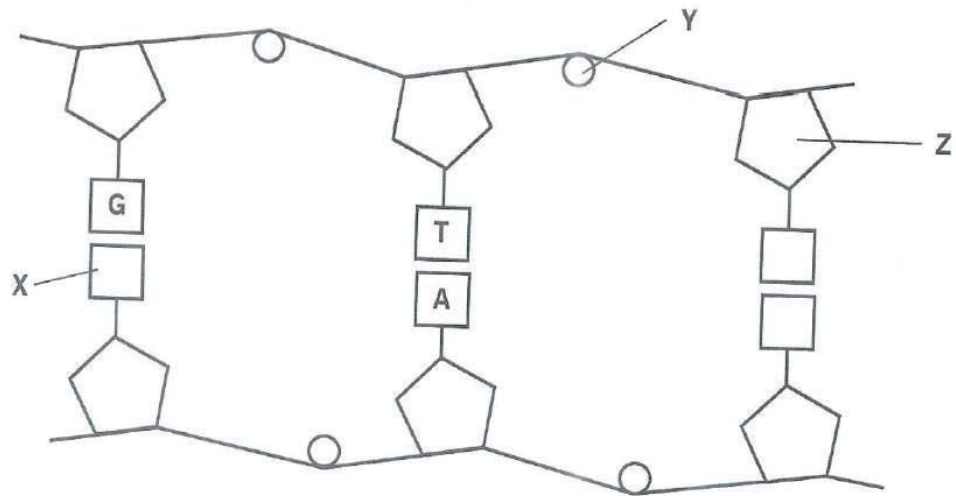

Fig. 5.1

(a) (i) Name the parts labelled X, Y and Z.

X : _____

Y : _____

Z : _____

[3]

(ii) Draw a circle around the components which make up **one** nucleotide on Fig. 5.1.

[1]

(b) Table 5.1 shows the percentage composition of bases in the DNA of rat. Complete the table.

Table 5.1

organism	% A	% C	% G	% T
rat	28			

[2]

6 Fig 6.1 shows a food web in a habitat.

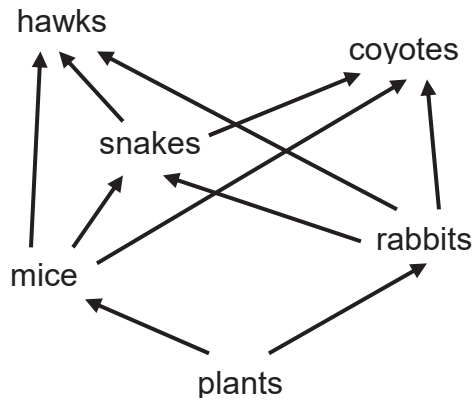

Fig. 6.1

(a) From this food web, name

(i) a herbivore,

_____ [1]

(ii) a carnivore

_____ [1]

(b) The disease myxomatosis kills most of the rabbits in this habitat. Predict and explain **one** significant impact this has on the food web.

 _____ [2]

(c) (i) From the food web in Fig. 6.1, construct a food chain with four trophic levels.

[1]

- (ii) Sketch a fully labelled pyramid of number for the food chain you have constructed in (i)

[2]

- (d) Suggest why food chains generally do not have more than four trophic levels.

[2]

Section B

Answer **two** questions from this section.
Write your answers in the spaces provided.

7 Fig. 7.1 shows the carbon cycle.

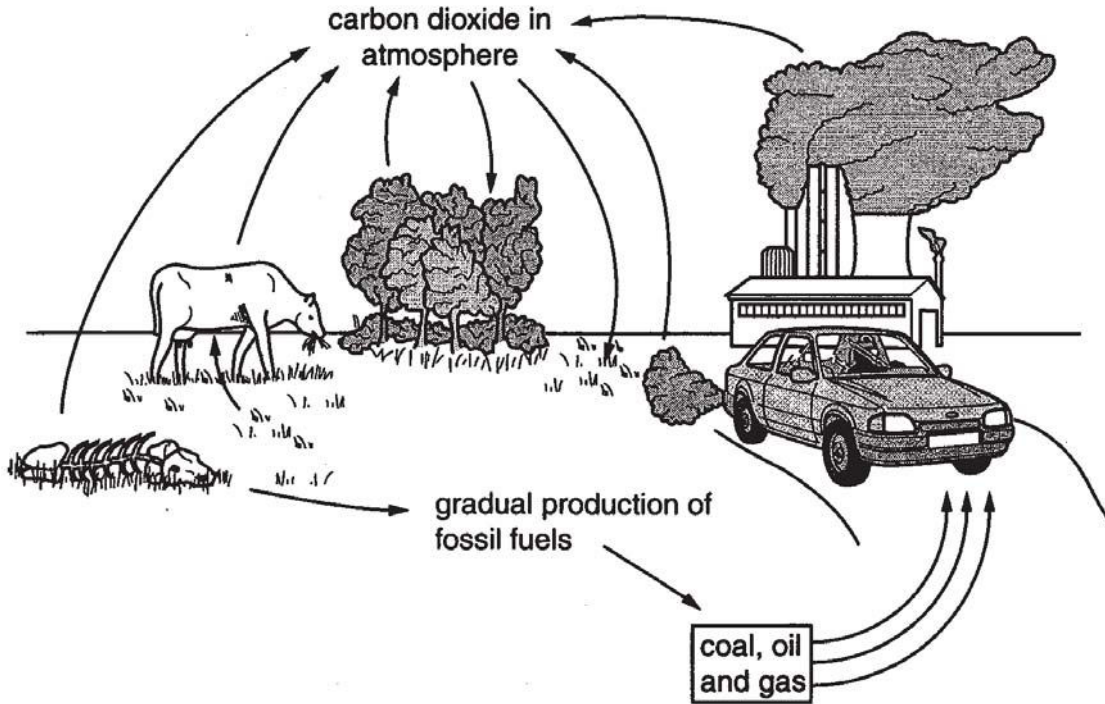

Fig. 7.1

(a) With reference to Fig. 7.1, explain how photosynthesis, respiration and animal nutrition are involved in the carbon cycle.

- 8 Fig. 8.1 shows the thickness of the uterus lining changes during a woman's menstrual cycle. Fig. 8.2 shows how concentrations of the hormones oestrogen and progesterone change during the same cycle.

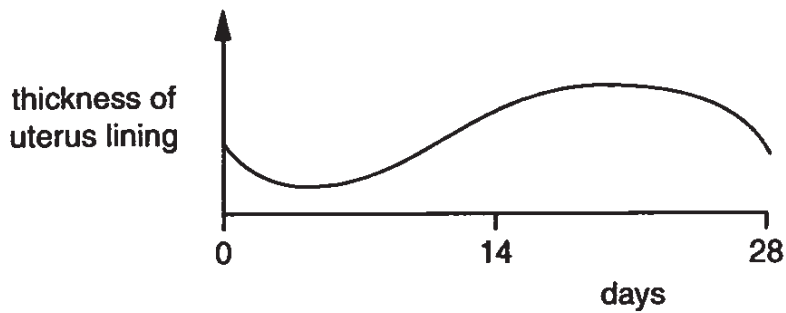

Fig. 8.1

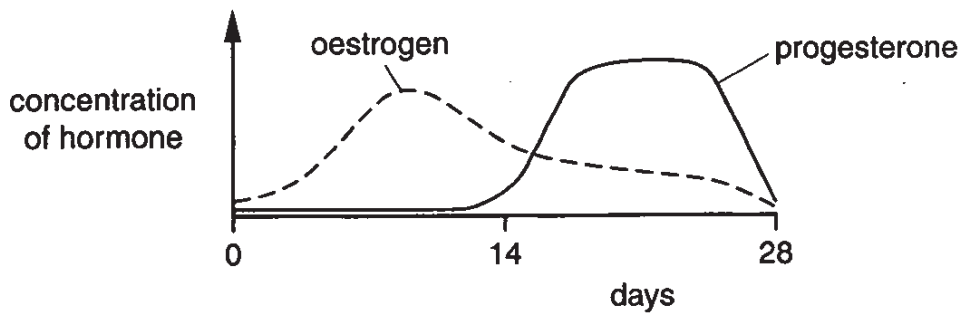

Fig. 8.2

- (a) Describe how the lining of the uterus changes from day 0 to day 28 of the menstrual cycle. Include in your description how the hormones oestrogen and progesterone affect the uterus lining during the menstrual cycle.

[6]

[6]

(b) (i) Suggest and explain what differences you would expect in Fig. 8.1 and Fig. 8.2 if an egg is fertilised during the cycle.

[2]

(ii) Explain why the woman's whole menstrual cycle is made up of fertile and non-fertile phases. Include which days are the fertile phase for this woman's cycle in your answer.

[2]

Geylang Methodist School Secondary
Preliminary Exam 2018
Science (Biology) Papers 1 and 4
Sec 4E/5NA

MARKING SCHEME

Paper 1 (Biology Section – Q21 to Q40))

Qn No.	21	22	23	24	25	26	27	28	29	30
<u>Ans</u>	C	A	D	A	D	B	A	B	C	B

Qn No.	31	32	33	34	35	36	37	38	39	40
Ans	B	C	A	C	A	D	D	B	A	A

Paper 4 (Biology)

<u>Section A</u>		
Qn. No	Answers	Marks
1 (a)	$\frac{(7.53 - 8.22)}{8.22} \times 100\%$ <p>% change in mass = - 8.4%</p>	1m 1m
1 (b)	<p>See graph on next page.</p> <p>Correctly labelled X-axis and scale Correctly labelled Y-axis and scale At least 4 out of 6 correctly marked plots Best fit line</p>	1m each Total 4m
1 (c)(i)	From the graph, concentration of cell sap is 4.4 mol per dm ³	1m
1 (c)(ii)	The sugar solution which results in no % change in mass of the potato indicates that there is no net movement of water. This can only happen if the water potential of the sugar solution is the same as that of the cell sap of the potato cells.	1m 1m

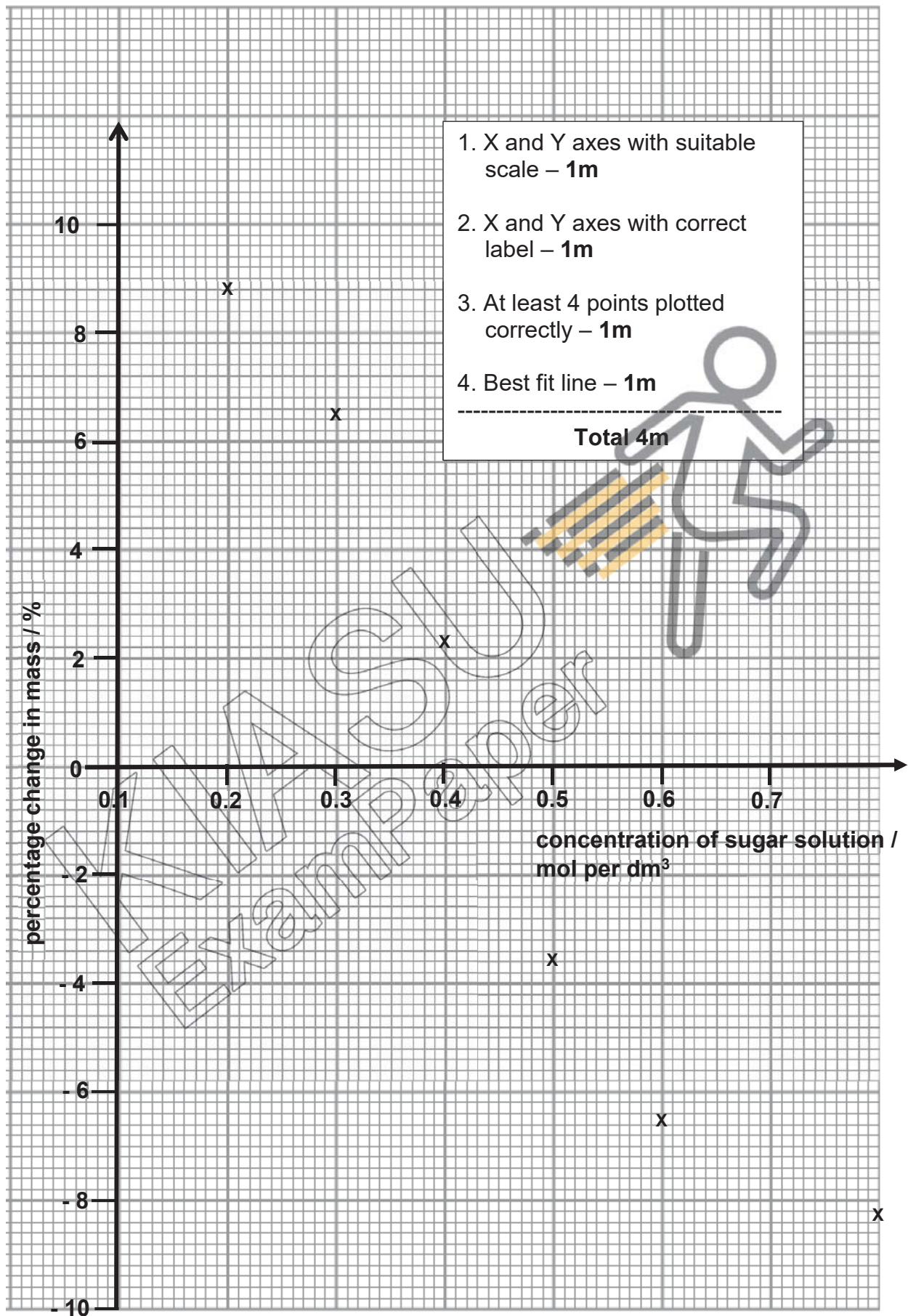

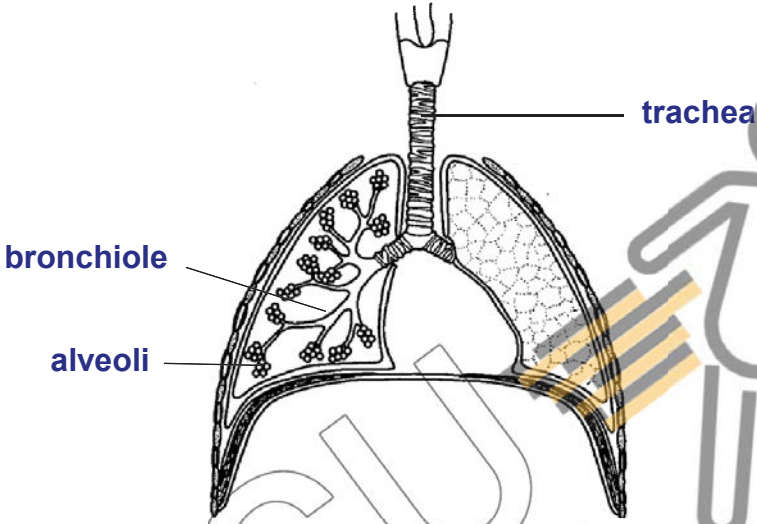
2 (a)	<p>Correctly labelled trachea, bronchiole and alveoli</p>  <p style="text-align: center;">Fig. 2.1</p>	<p>1m each correctly identified and labelled part ----- Total 3m</p>
2 (b)	<ol style="list-style-type: none"> 1. <u>Spherical shape of the alveoli</u> provides a large surface area to volume ratio which increases the rate of oxygen transfer. 2. <u>Thin / one-cell thick alveolar wall</u> which reduces the distance oxygen has to diffuse through to get to the capillaries. 3. <u>Presence of a thin film of moisture</u> in the inner surface of the alveolus enables oxygen to dissolve in which facilitates the diffusion of the oxygen across the alveolus. <p>Note: question is about “structure of alveoli”, hence any reference to features other than this is not accepted, e.g. proximity of blood capillaries</p>	<p>1m 1m 1m ----- Total 3m</p>
2 (c)(i)	<ol style="list-style-type: none"> 1. Nicotine 2. Tar 3. Carbon monoxide 	<p>1m each ----- Total 3m</p>
2 (c)(ii)	<p>Any TWO of the 3 ways:</p> <ol style="list-style-type: none"> 1. Irritants and tar in the cigarette smoke causes <u>inflammation of the bronchioles (bronchitis)</u>, a condition in which the passage of air in the bronchial tubes is blocked due to the secretion of large amounts of mucus. 2. Prolonged smoking causes <u>emphysema</u> where the <u>alveolar walls breakdown</u> resulting in a reduced surface area for oxygen absorption. 3. Carcinogens in cigarette smoke cause the cells in the lungs to grow uncontrollably leading to <u>cancer</u>. 	<p>1m for each correct answer. ----- Total 2m</p>

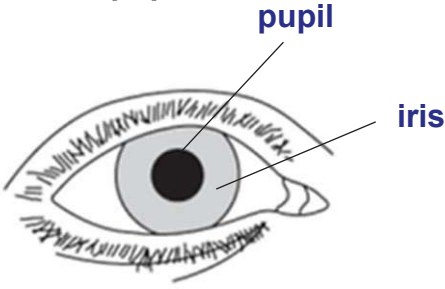
3 (a)	<p>Correctly labelled iris and pupil</p>  <p style="text-align: center;">Fig. 3.1</p>	<p>1m each correctly identified and labelled part ----- Total 2m</p>
3 (b)	<p>When the eye is exposed to bright light, the pupil automatically becomes smaller / constricts.</p> <p>This is due to the circular muscles of the iris which contract while radial muscles (of the iris) relax (max 1m if 'iris' is omitted)</p>	<p>1m 1m 1m ----- Total 3m</p>

4 (a)(i)	Hh	1m													
4 (a)(ii)	hh	1m													
4 (b)	<table border="1" style="margin-left: auto; margin-right: auto;"> <tr> <td colspan="2" rowspan="2"></td> <td colspan="2" style="text-align: center;">father R</td> </tr> <tr> <td style="text-align: center;">H</td> <td style="text-align: center;">h</td> </tr> <tr> <td rowspan="2" style="text-align: center;">mother S</td> <td style="text-align: center;">H</td> <td style="text-align: center;">HH unaffected</td> <td style="text-align: center;">Hh unaffected</td> </tr> <tr> <td style="text-align: center;">h</td> <td style="text-align: center;">Hh unaffected</td> <td style="text-align: center;">hh affected</td> </tr> </table>			father R		H	h	mother S	H	HH unaffected	Hh unaffected	h	Hh unaffected	hh affected	<p>1m for correct parental gametes</p> <p>1m for correct offspring genotype and phenotype</p>
				father R											
		H	h												
mother S	H	HH unaffected	Hh unaffected												
	h	Hh unaffected	hh affected												
	Chance of the child having the disorder = 25% or 1/4	1m													

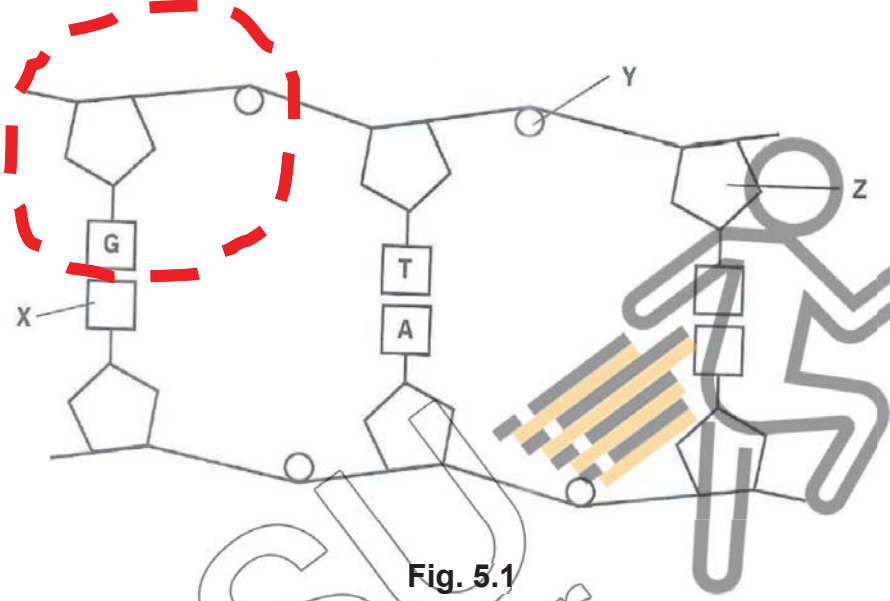
5 (a)(i)	 <p style="text-align: center;">Fig. 5.1</p>											
	X: cytosine	1m										
	Y: phosphate	1m										
	Z: deoxyribose sugar Reject 'sugar'	1m										
5 (a)(ii)	ANY correctly circled nucleotide consisting of a pentose sugar, phosphate and nitrogenous base.	1m										
5 (b)	<p style="text-align: center;">Table 5.1</p> <table border="1" data-bbox="327 1182 1216 1335"> <thead> <tr> <th>organism</th> <th>% A</th> <th>% C</th> <th>% G</th> <th>% T</th> </tr> </thead> <tbody> <tr> <td>rat</td> <td>28</td> <td>22</td> <td>22</td> <td>28</td> </tr> </tbody> </table>	organism	% A	% C	% G	% T	rat	28	22	22	28	1m for correct %T 1m for correct %C or %G <hr style="width: 10%; margin: 0 auto;"/> Total 2m
organism	% A	% C	% G	% T								
rat	28	22	22	28								

6 (a)(i)	mouse / rabbit	1m
6 (a)(ii)	snake / hawk / coyote	1m
6 (b)	Population of mice will increase.	1m
	More plants available for mice to feed on.	1m
6 (c)(i)	ANY ONE of the following food chains: plants → mice → snakes → hawks plants → mice → snakes → coyotes plants → rabbits → snakes → hawks plants → rabbits → snakes → coyotes	1m

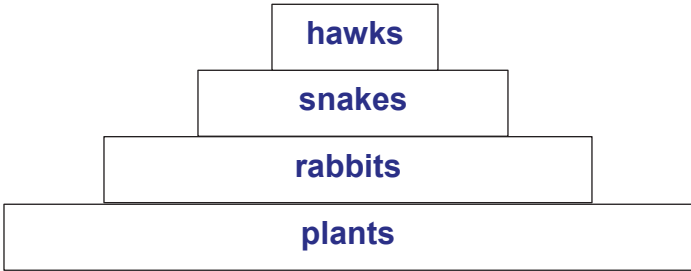
6 (c)(ii)	Pyramid of number 	1m for correct relative size of trophic levels 1m for regular height
6 (d)	About 90% of energy is lost to the environment during energy transfer from one trophic level to the next in the food chain. Hence an organism beyond the 4 th trophic level would not be able to obtain sufficient energy to sustain life.	1m 1m <hr/> Total 2m

Section B

7 (a)	<p><u>CO₂ in the atmosphere is constantly removed by all green plants for the process of photosynthesis.</u></p> <p>During this process, carbon is used to make <u>carbohydrate/ glucose molecules</u> which the plants use for <u>tissue respiration</u> to release energy for their cellular activities.</p> <p><u>Excess glucose made is either stored up in the plant as starch / converted to other organic compounds within the plant body</u></p> <p>When herbivorous <u>animals feed on the green plants</u> (animal nutrition), the carbon locked in the plant body is <u>transferred into and becomes part of the animal.</u></p> <p>When the animal uses the carbon compound glucose for tissue respiration, CO₂ is produced which is returned back into the atmosphere.</p>	1m 1m 1m 1m 1m <hr/> Total 6m
7 (b)	<p>The burning of fossil fuels (such as coal, oil and gas) releases the locked-up carbon in the fossil fuels as CO₂ into the atmosphere.</p> <p>An increase in the burning of fossil fuels therefore will result in <u>more CO₂ being released into the atmosphere.</u></p> <p>Forests comprise green plants/trees which play a major role in removing CO₂ from the atmosphere for the process of photosynthesis.</p>	1m 1m 1m

	Increasing destruction of the world's forests will mean that less CO ₂ in the atmosphere will be removed, causing CO ₂ levels to remain high.	1m
		Total 4m

8 (a)	From <u>day 0 to day 5</u> , <u>menstruation occurs</u> during which the <u>uterine lining breaks down</u> and its thickness decreases.	1m
	From day <u>6 to day 10</u> , increasing oestrogen level promotes the repair and growth of the uterine lining.	1m
	As the concentration of oestrogen increases further, the uterine starts to thicken from day 11 to day 17.	1m
	From day 18 onwards, under the influence of increasing progesterone level, the uterine lining <u>continues to thicken further</u> and is <u>maintained</u> .	1m 1m
	At day 28 when the level of progesterone has decreased sharply, the uterine lining can no longer be maintained and it starts to break down, marking the end of the menstrual cycle (and the beginning of the next cycle).	1m ----- Total 6m
8 (b)(i)	If an egg is fertilised during the cycle, <u>The level of progesterone in Fig. 8.2 will continue to remain high in order to maintain the uterine lining / prevents the uterine lining from breaking down</u>	1m
	<u>The thickness of the uterine lining in Fig. 8.1 will remain high to enable the fertilised egg/zygote to be implanted so that it can continue to grow and develop into a foetus</u>	1m Total 2m
8 (b)(ii)	A ripe/mature egg is released from the ovary between day 11 and day 17 of the menstrual cycle which represents the fertile phase of the cycle as the chance of egg being fertilised by a sperm is very high.	1m
	Hence outside of day 11 to day 17, the chance of fertilisation is very low or non-existent, representing the non-fertile period of the menstrual cycle.	1m Total 2m

9 (a)	1. A typical plant cell has <u>chloroplasts containing chlorophyll</u> while a typical animal cell does not have. Chlorophyll in the chloroplasts of plant cells enables the plant to <u>absorb sunlight</u> for the process of <u>photosynthesis to make food</u> which is essential for the survival of the plant.	1m
		1m
	2. A typical plant cell has a <u>cell wall</u> which is absent in a typical animal cell. Cell wall provides <u>protection against mechanical damage</u> and gives shape to the cell, both essential for the survival of the plant.	1m
		1m
	3. A typical plant cell has a <u>large central vacuole</u> whereas a typical animal cell has <u>numerous small vacuoles</u> . A large central vacuole allows the cell to store water and nutrients and keep the cell turgid, which enables soft tissues in the plant to stay erect.	1m
		1m
		Total 6m
9 (b)	Any TWO of the following:	
	1. A red blood cell (RBC) has <u>haemoglobin</u> which is absent in a typical animal cell. Haemoglobin <u>binds reversibly to oxygen</u> which enables the RBC to transport oxygen <u>from the lungs to all parts of the body</u> .	1m
		1m
	2. <u>Nucleus</u> is present in a typical animal cell but absent in a RBC. Absence of a nucleus enables the RBC to <u>pack in more haemoglobin</u> and thus it can <u>carry more oxygen</u> .	1m
		1m
	3. A RBC has a <u>biconcave disc shape</u> , unlike the irregular shape of a typical animal cell. The biconcave shape of the RBC <u>increases its surface area to volume ratio</u> , allowing oxygen to <u>diffuse</u> into and out of the RBC at a <u>faster rate</u> .	1m
		1m
		Total 4m

End of Paper

