



RAFFLES GIRLS' PRIMARY SCHOOL

SEMESTRAL ASSESSMENT (1)

2012

Name : _____ Index No: _____ Class: P4 _____

2 May 2012

SCIENCE

Att: 1 h 45 min

Section A	60	
Section B	40	
Your score out of 100 marks		
Highest score	Class	Level
Average score		
Parent's signature		

SECTION A (30 x 2 marks)

For each question from 1 to 30, four options are given.

One of them is the correct answer. Make your choice (1, 2, 3 or 4).

Shade the correct oval (1, 2, 3 or 4) on the Optical Answer Sheet (OAS) provided.

1. Ahmad prepared 4 set-ups as shown below to find out if living things need air to survive.

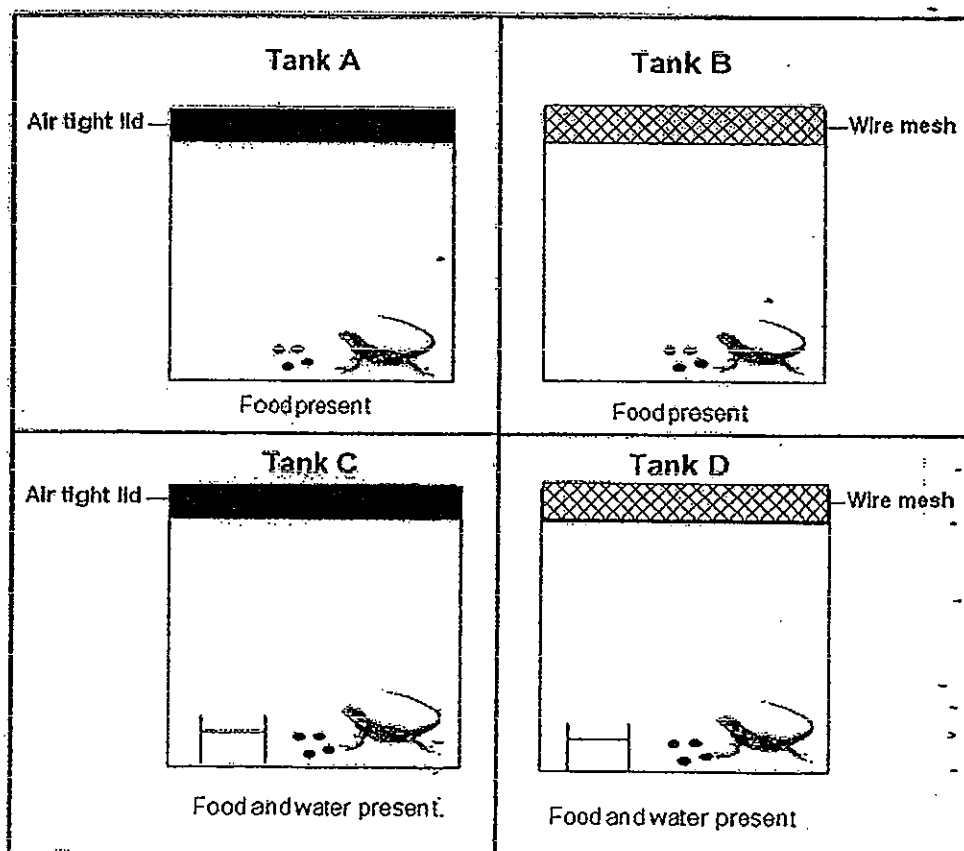

Which pair of set-ups should Ahmad choose to conduct a fair test?

- (1) Tank A and C
- (2) Tank B and C
- (3) Tank C and D
- (4) Tank B and D

2. The chart below shows how some animals are classified.

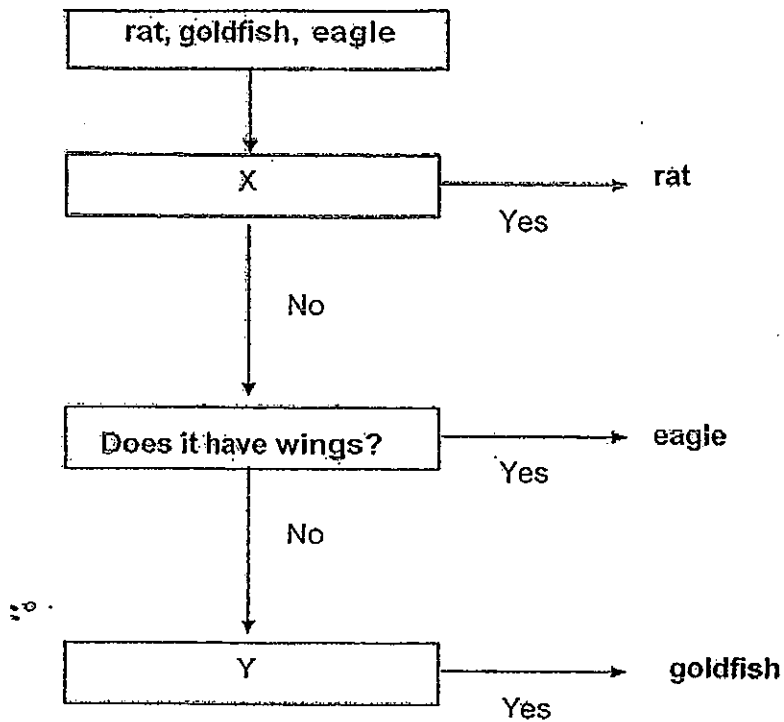

Which one of the following are suitable questions in boxes X and Y respectively?

	X	Y
(1)	Does it lay eggs?	Does it have fur?
(2)	Does it give birth to its young?	Does it have gills?
(3)	Does it lay eggs?	Does it swim?
(4)	Does it give birth to its young?	Does it have feelers?

3. Study the information of 4 different animals, P, Q, R and S, in the table below.

Characteristics	Animal P	Animal Q	Animal R	Animal S
Body parts	3	3	2	3
Pairs of legs	3	3	4	3
Pairs of wings	1	2	0	0
Antennae	Yes	Yes	No	No

The picture below shows one of the animals mentioned above.

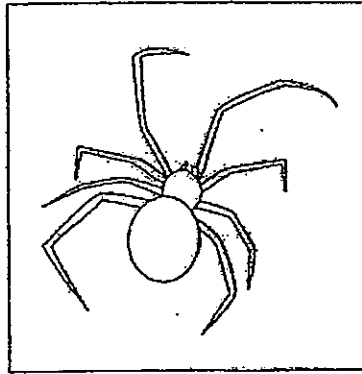

Which of the following animals correctly represents the animal shown in the diagram above?

- (1) Animal P
- (2) Animal Q
- (3) Animal R
- (4) Animal S



4. The chart below shows how some organisms are classified.

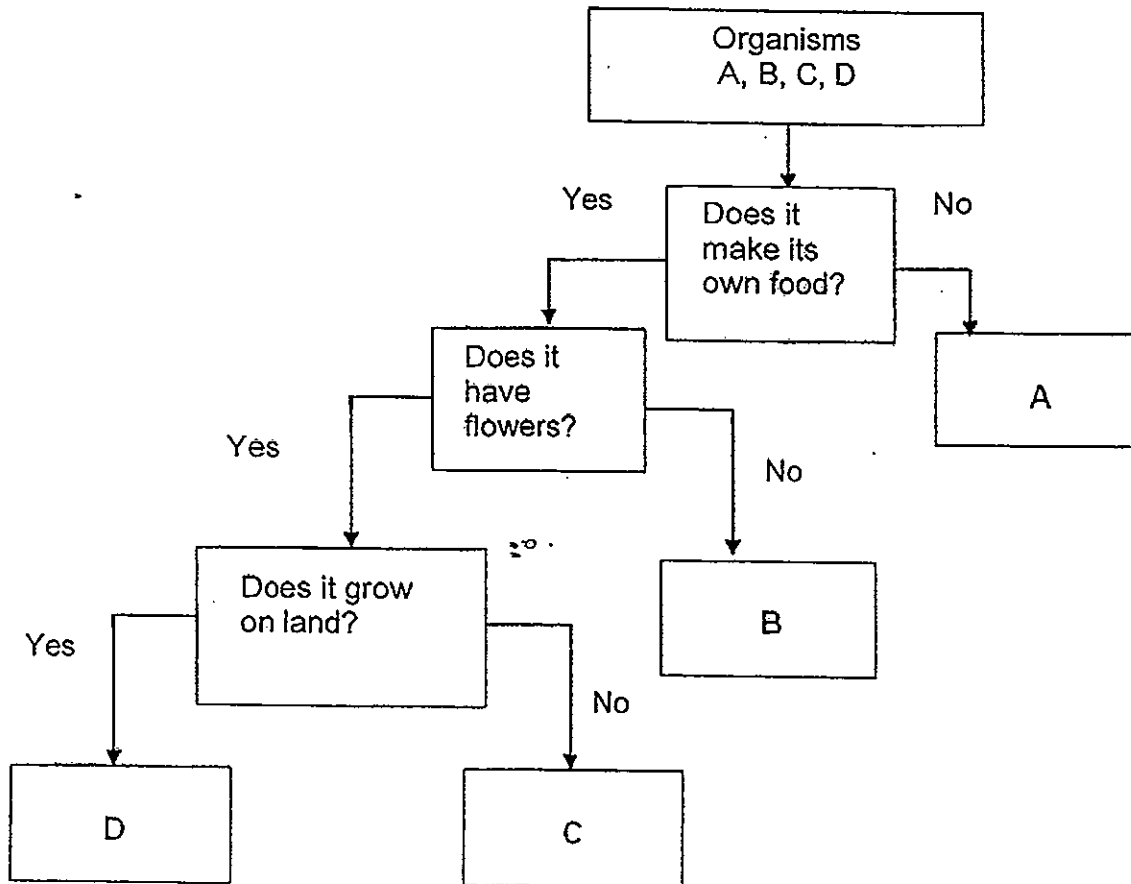

Which of the following best represent A, B, C and D as shown in the chart above?

	A	B	C	D
(1)	papaya plant	ladder fern	mushroom	sunflower
(2)	mushroom	mango	water lily	balsam
(3)	bracket fungus	moss	lotus	hibiscus
(4)	mould	pine	balsam	water lily

5. The diagrams below show two organisms, X and Y.

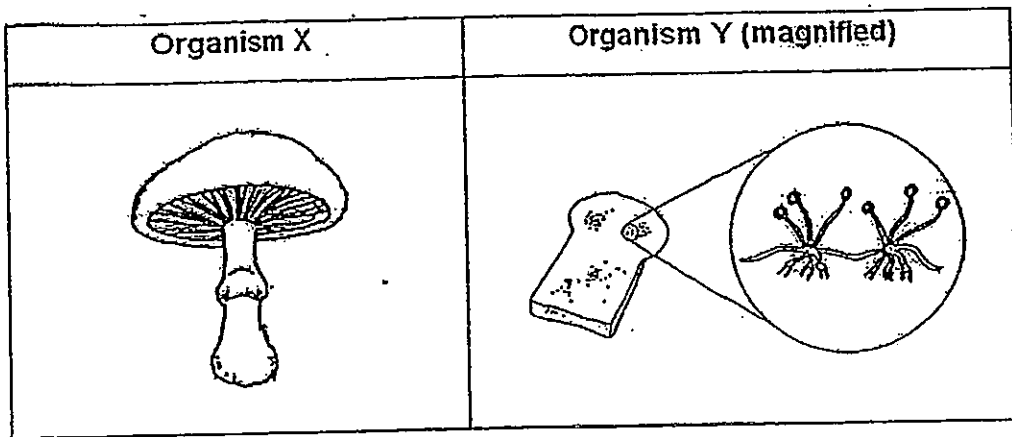

Some pupils made the following statements on the organisms X and Y above.

- Pupil A: X and Y are plants.
 Pupil B: X and Y make their own food.
 Pupil C: X and Y feed on dead and living organisms.

Which of the following pupil(s) gave the correct statement(s)?

- (1) B only
- (2) C only
- (3) A and B only
- (4) A and C only

6. Mei Li observed two animals, X and Y, over a period of time and recorded her observations in the table below.

Observations	Animal X	Animal Y
Eggs are laid in water.	✓	
There are 4 stages in its life cycle.	✓	✓
It is a pest when in its larval stage.		✓
The adult has three pairs of legs.	✓	✓

Based on the information above, which of the following best represent animals, X and Y respectively?

	Animal X	Animal Y
(1)	dragonfly	housefly
(2)	housefly	mosquito
(3)	mosquito	cockroach
(4)	mosquito	butterfly

7. The stages in the life cycle of a mosquito are shown below.
 [Stages A, B, C and D are NOT arranged in order.]

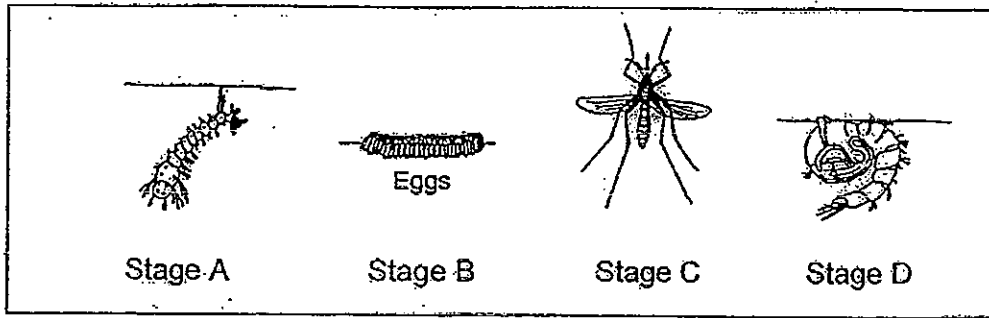

Which one of the following shows the stages of the life cycle of the mosquito in the correct order?

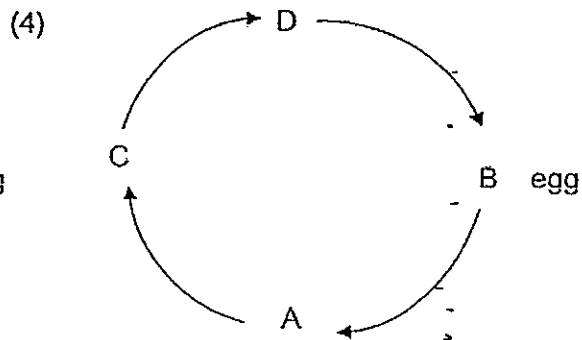
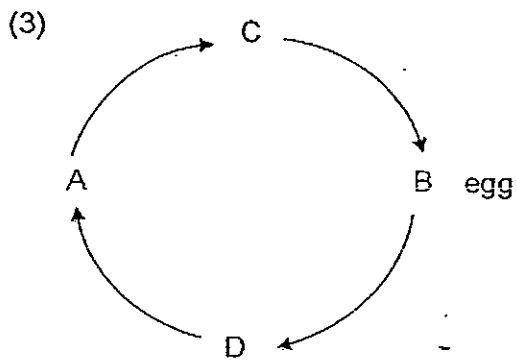
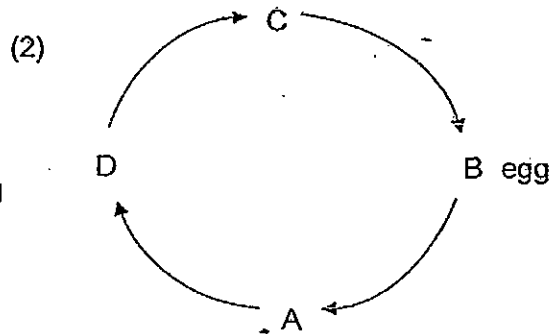
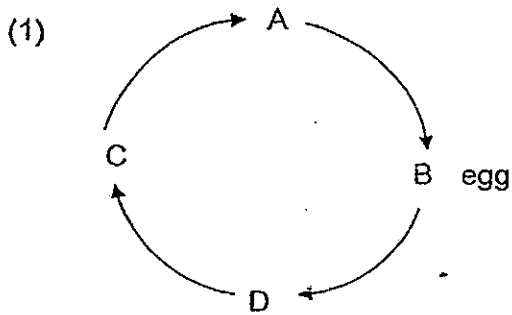

8. The diagram below shows part of the different stages, P, Q and R, of a plant.

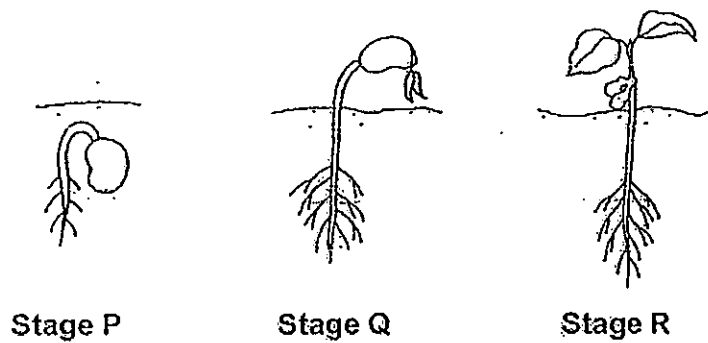

At which stage(s) shown above does/ do the seed leaves provide food for the plant?

- (1) P only
- (2) P and Q only
- (3) Q and R only
- (4) P, Q and R

9. Nicole put the seeds of the lady's finger plant in four glass containers, P, Q, R and S, under the conditions laid out in the diagrams below.

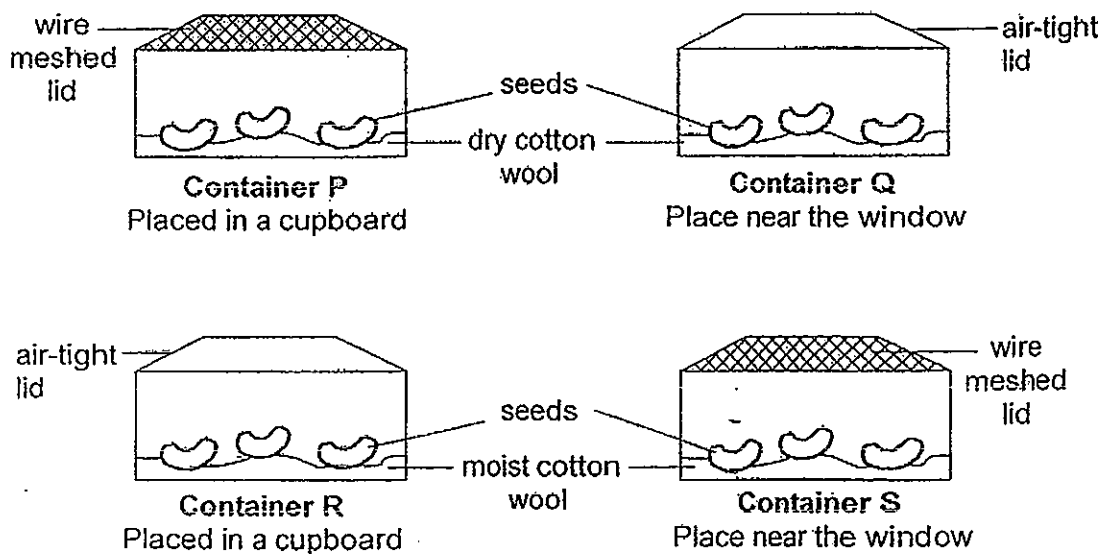

Which container(s) will the seeds most likely to germinate?

- (1) P only
- (2) S only
- (3) P and S only
- (4) Q and R only

10. The diagram below shows part of the digestive system.

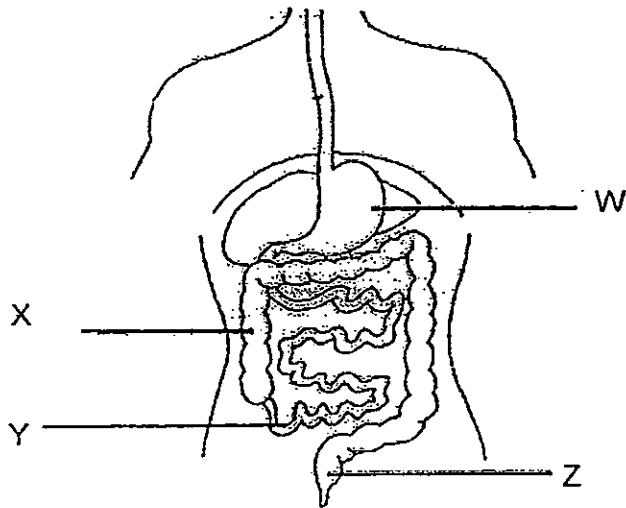

In which part of the human digestive system is digested food absorbed into the blood stream?

- (1) W
- (2) X
- (3) Y
- (4) Z

11. Four different human body systems are shown in the diagrams below.

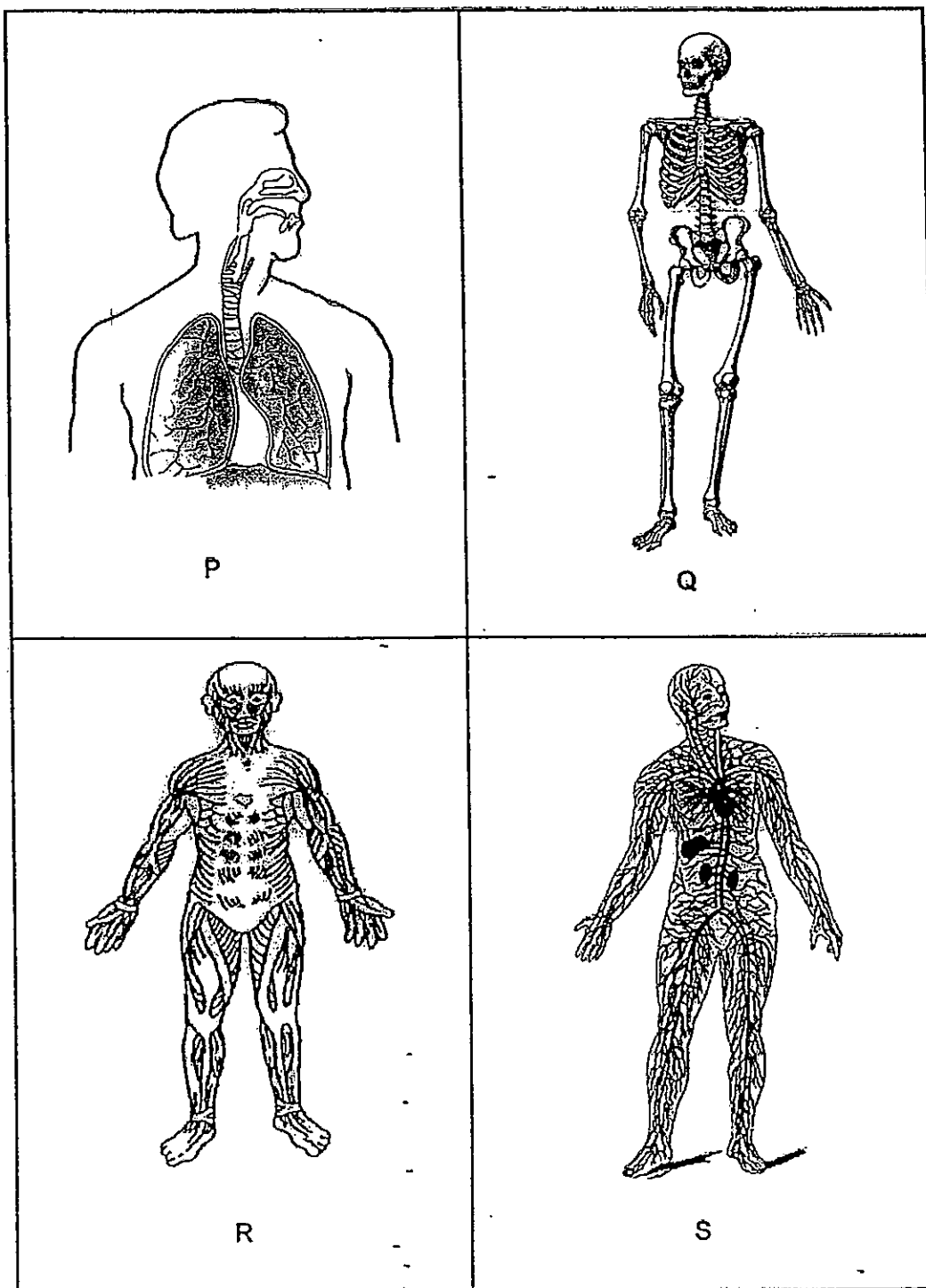

Which pair of systems work together to enable the body to move?

- (1) P and Q
- (2) Q and R
- (3) R and S
- (4) P and S

12. Study the classification table below.

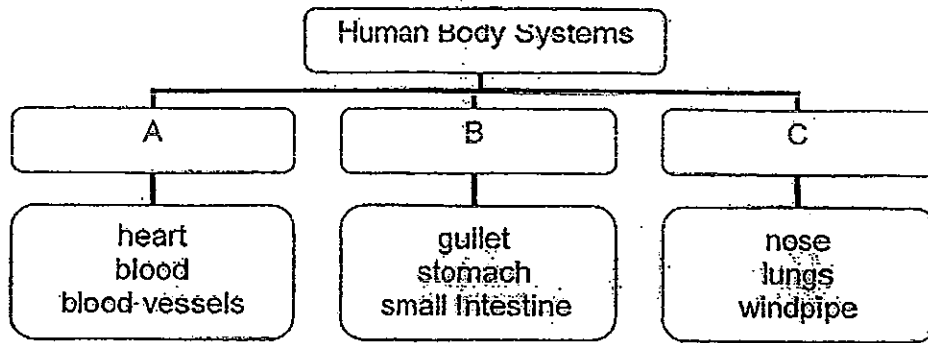

Which one of the following sets of systems matches the headings, A, B and C?

	A	B	C
(1)	muscular system	digestive system	circulatory system
(2)	circulatory system	respiratory system	digestive system
(3)	skeletal system	circulatory system	muscular system
(4)	circulatory system	digestive system	respiratory system

13. Cassandra had a few slices of bread for breakfast. The chart below shows the amount of food digested in various parts of the human digestive system after her meal:

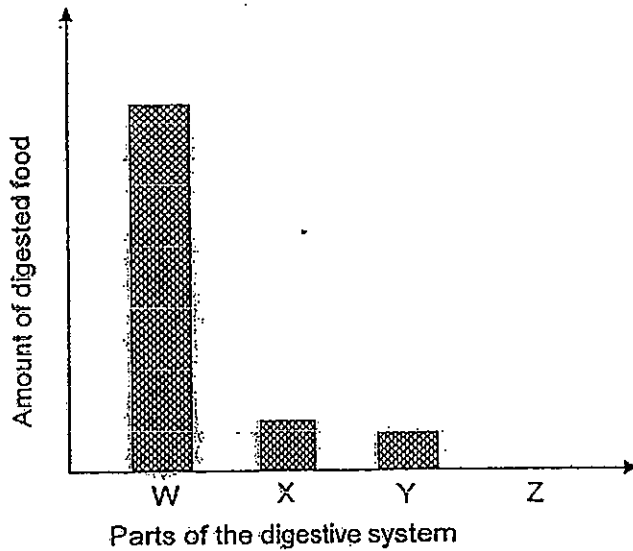

Based on the graph above, which one of the following best represents W, X, Y and Z respectively?

	W	X	Y	Z
(1)	small intestine	large intestine	stomach	mouth
(2)	stomach	mouth	small intestine	large intestine
(3)	stomach	small intestine	large intestine	mouth
(4)	small intestine	stomach	mouth	large intestine

14. Mary studied the stem of a balsam plant and made the following statements.

- A It holds the plant upright.
- B It helps the plants absorb water.
- C It contains tubes that help to transport food from the roots to the leaves.
- D It contains tubes that help to transports water from the roots to the leaves.

Which of the above statements made about the stem are correct?

- (1) A and D only
- (2) B and C only
- (3) A, C and D only
- (4) A, B, C and D

15. Alvin set up the following experiment using similar plants as shown in the diagram below. The roots of the plant in Set-up B were removed. He left both set-ups near the window for 3 days.

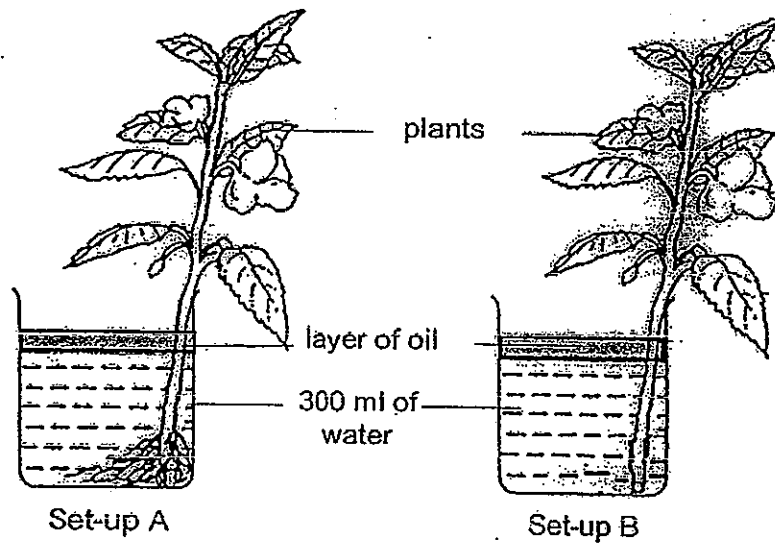

Which of the following graphs below shows the correct change in the amount of water observed in both set-ups after 3 days?

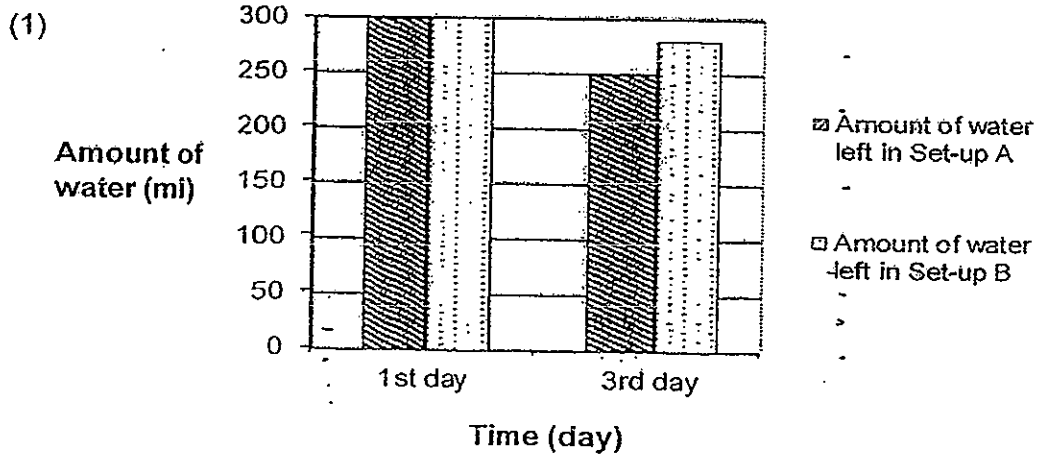

(2)

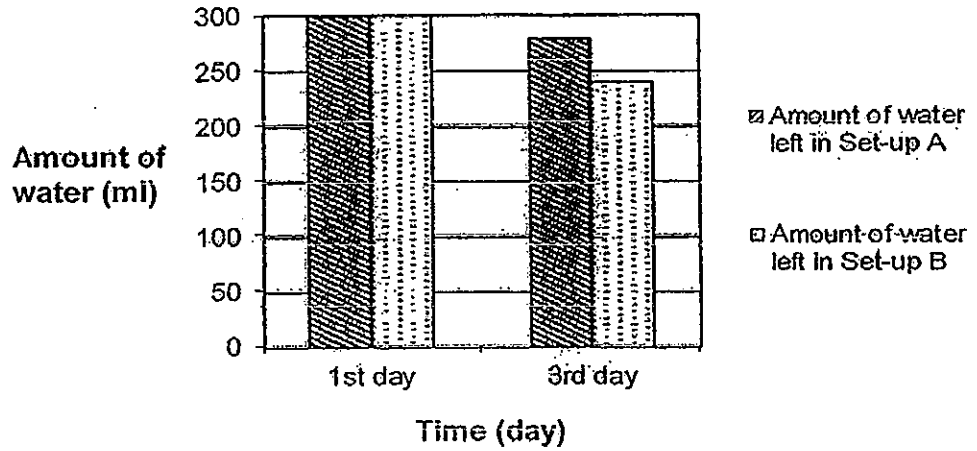

(3)

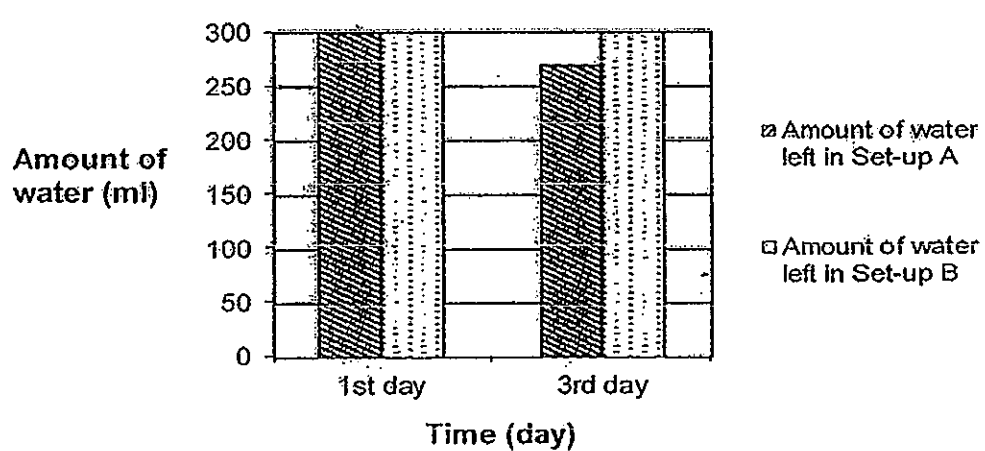

(4)

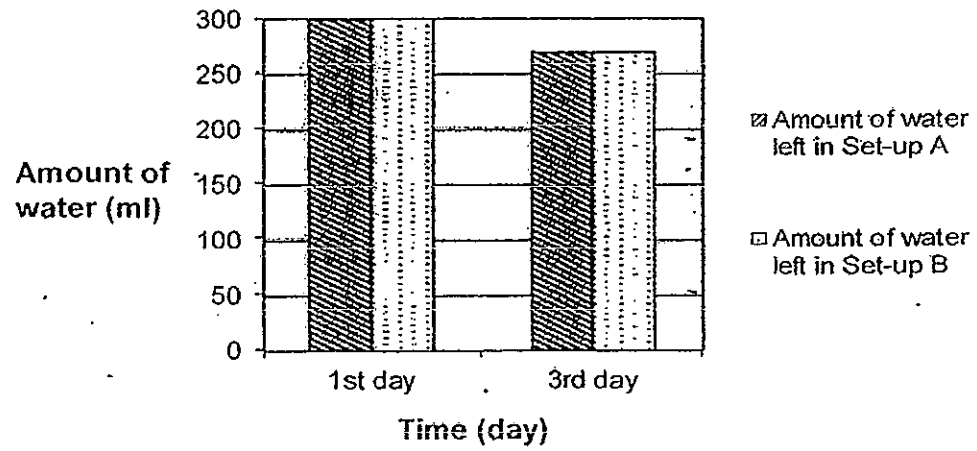

16. Peter took part of a blade from a fern and dipped it in a beaker of red-coloured water for a day as shown below.

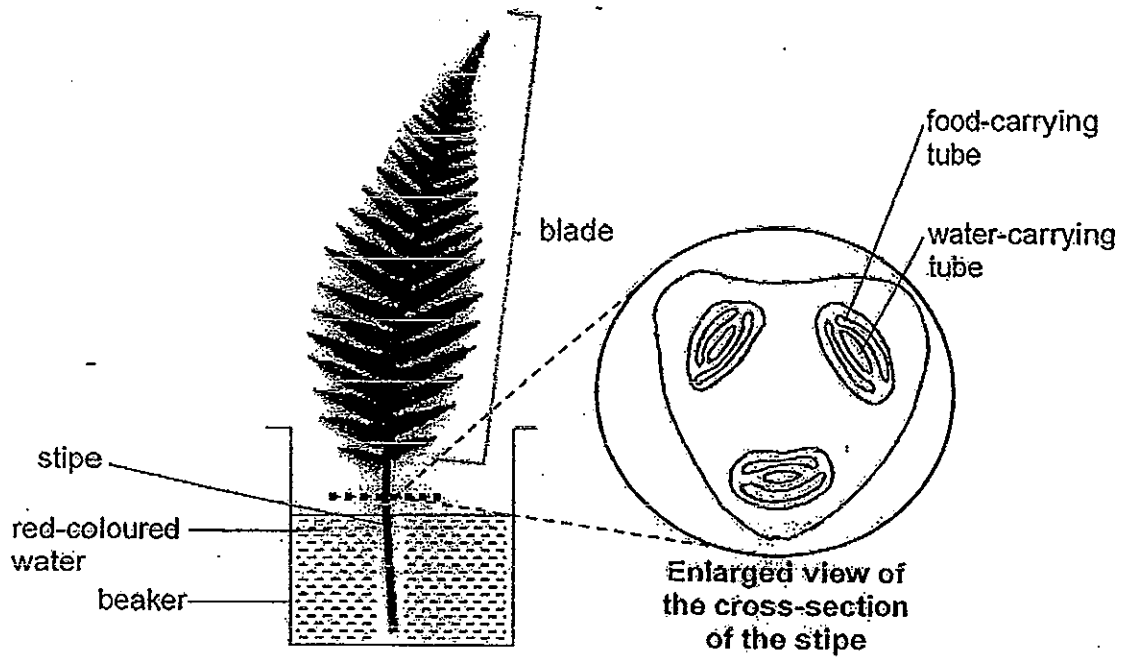

The next day, he cut out a cross-section of the stipe and observed that some parts within it had turned red.

Which one of the following diagrams show the parts of the stem which had turned red?

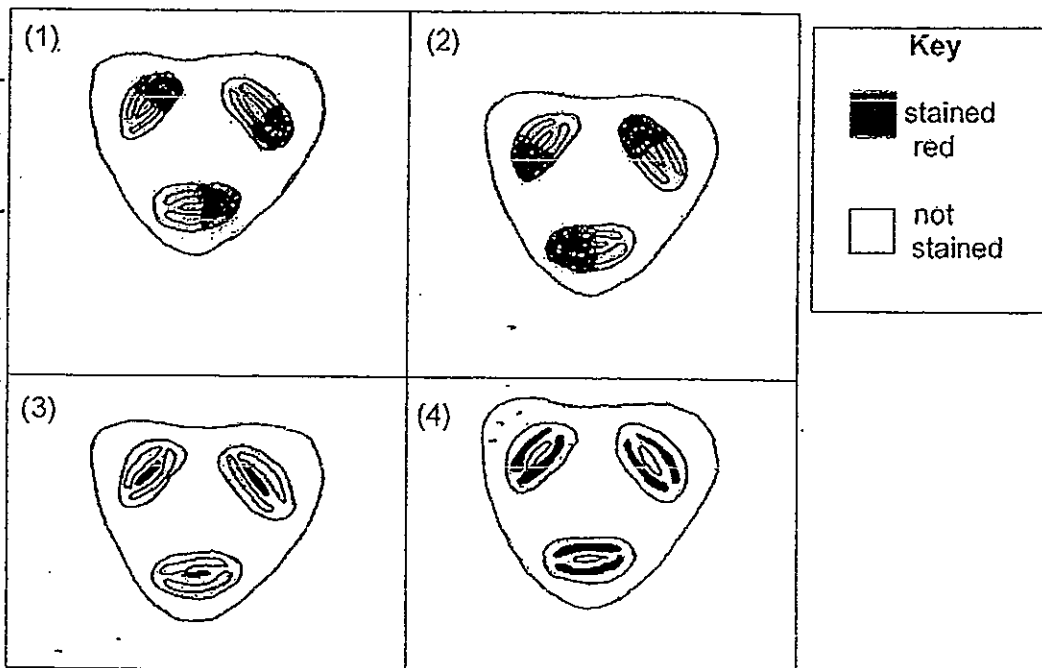

17. Sue wants to find out if the stem of a flower absorbs water. She placed a white flower in a beaker containing 250 ml of blue coloured water as shown below.

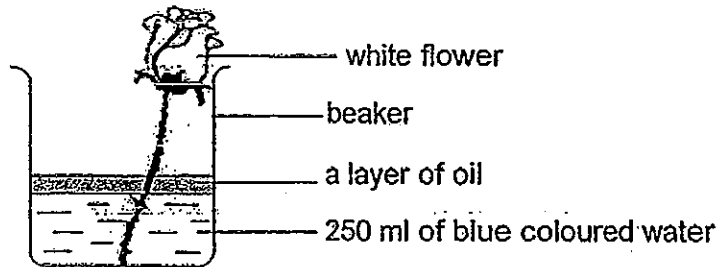

Which one of the following should she use as a control set-up?

(1)

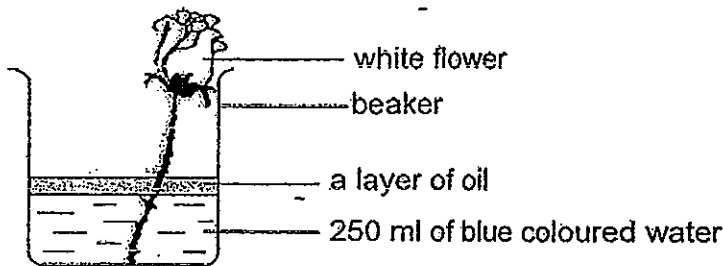

(2)

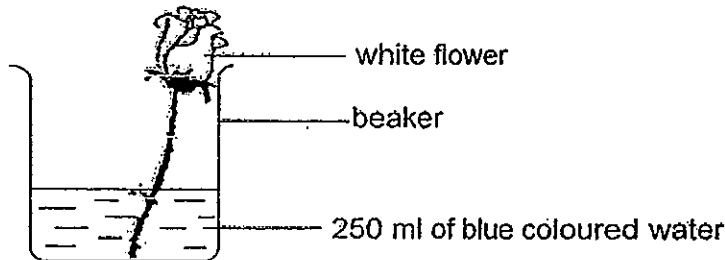

(3)

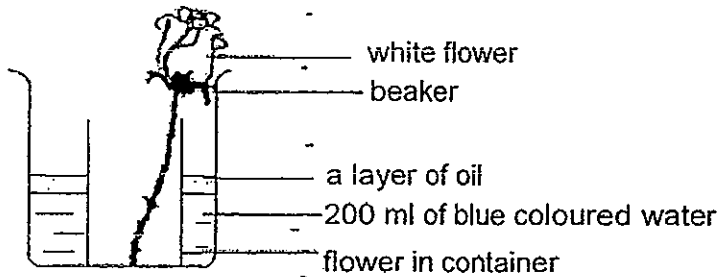

(4)

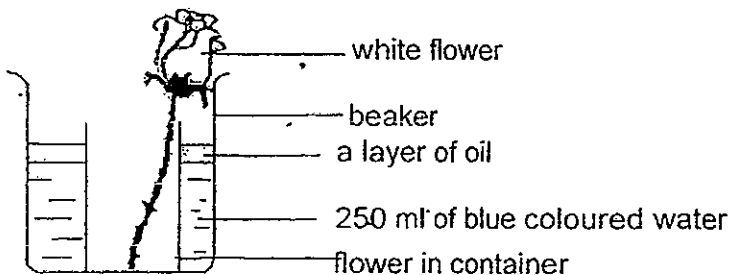

18. Objects X and Y are made of materials that have the characteristics recorded in the table below.

Characteristics	X	Y
Hard	✓	
Strong	✓	
Flexible		✓
Waterproof	✓	✓

What of the following most likely to represent objects X and Y respectively?

	X	Y
(1)	aluminium can	wooden plank
(2)	ceramic mug	cotton blouse
(3)	steel rod	rubber band
(4)	rubber hose	raincoat

19. Mui Ling wanted to find out the hardness of 4 materials, A, B, C and D, and performed scratch tests on each of them. The result of her investigation is shown in the table below.

Properties Materials	Can be scratched by iron nail	Can be scratched by wooden stick	Can be scratched by fingernail
A	✓		
B	✓	✓	✓
C	✓	✓	
D			

Which one of the following arrangement of the materials A, B, C and D is in the order from the hardest to the softest?

- (1) ACBD
- (2) BCAD
- (3) CABD
- (4) DACB

20. Which of the following items are matter?

- A Wind
- B Sunlight
- C Electricity
- D Rainwater

- (1) A and B only
- (2) B and C only
- (3) A and D only
- (4) B, C and D only

21. A balloon attached to a hollow glass tube was pushed into a container of water as shown below.

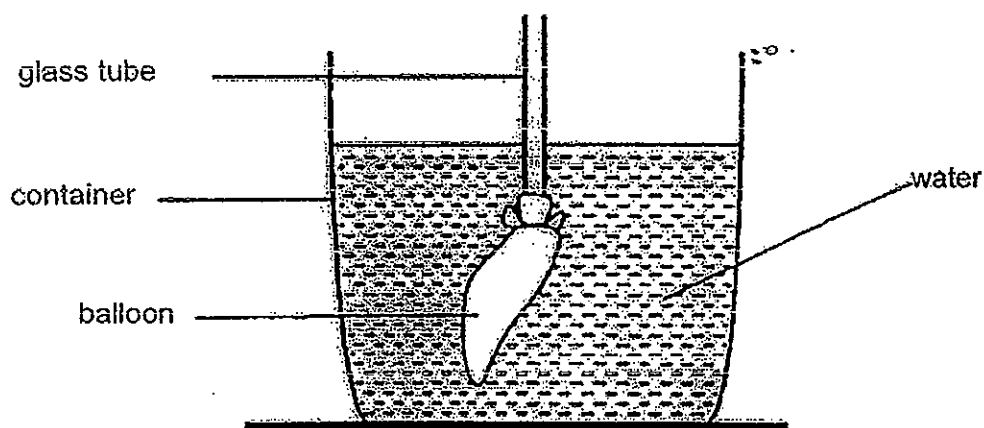

Megan placed her mouth over the open end of the glass tube and blew air into it to inflate the balloon slightly. When Megan blew air into the tube, she observed that the water level in the container rose.

This experiment showed that air _____.

- A has mass
- B occupies space
- C cannot be compressed

- (1) B only
- (2) C only
- (3) A and B only
- (4) A, B and C

22. Muthu filled an empty measuring cylinder up to the 100 ml mark with marbles as shown in the diagram below.

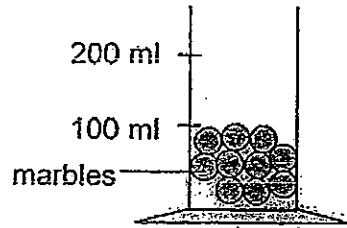

He then poured 100 ml of water into the measuring cylinder containing the marbles.

Which of the following most likely shows the water level in the measuring cylinder correctly?

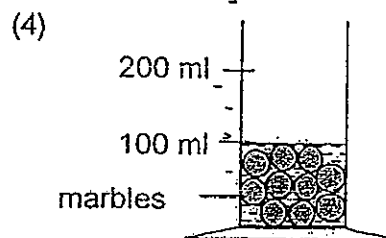
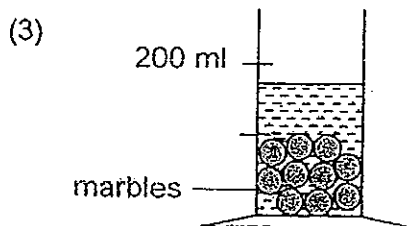
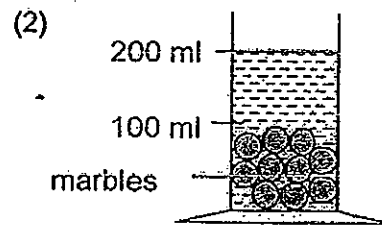
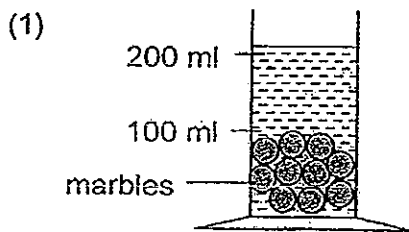

23. Polly carried out an experiment as shown in the diagram below. She connected a pump to a glass jar with a capacity of 300 cm^3 . The jar contains 100 cm^3 of water.

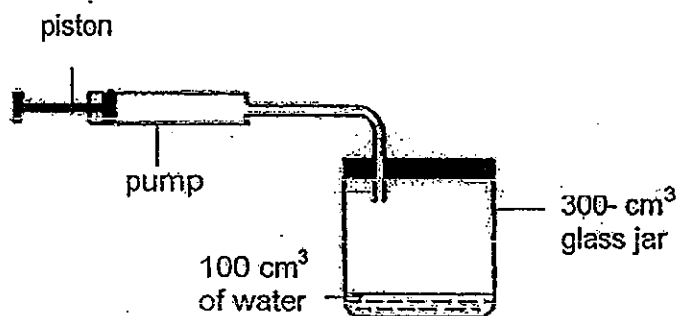

Polly pushed the piston completely and pumped 100 cm^3 of air into the jar. What would be the volume of air in the jar?

- (1) 100 cm^3
 - (2) 200 cm^3
 - (3) 300 cm^3
 - (4) 500 cm^3
24. Mr Sim had 8 bricks and he wished to put all of them neatly in a metal box as shown below.

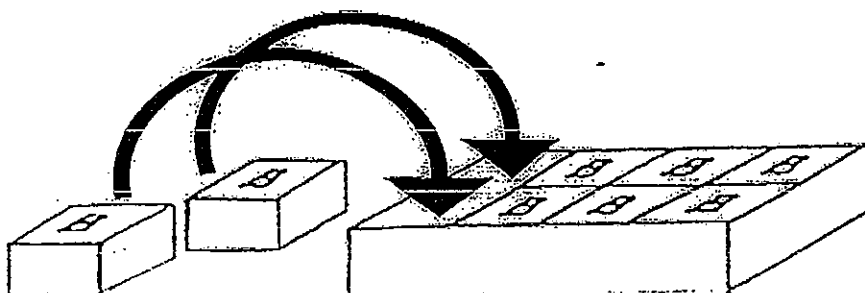

He tried to squeeze 2 more bricks in the space left in the box above. However, he was unable to do so. He came up with several reasons as shown below.

- A The bricks have a fixed shape.
- B The metal box has a fixed volume.
- C The bricks cannot be compressed.
- D The bricks do not have a definite mass.

Which of the following most likely to explain why he was unsuccessful in his attempt to fit the 2 additional bricks into the box?

- (1) A and C only
- (2) A, B and C only
- (3) B, C and D only
- (4) A, B, C and D

25. Which one of the following statements about magnets is true?

- (1) All magnets are made of iron.
- (2) Magnets can attract and repel all metals.
- (3) Magnetic force of attraction is the strongest at the poles.
- (4) The bigger the magnet, the greater its magnetic strength.

26. Zhiyong was given 3 rods, P, Q and R, as shown below.

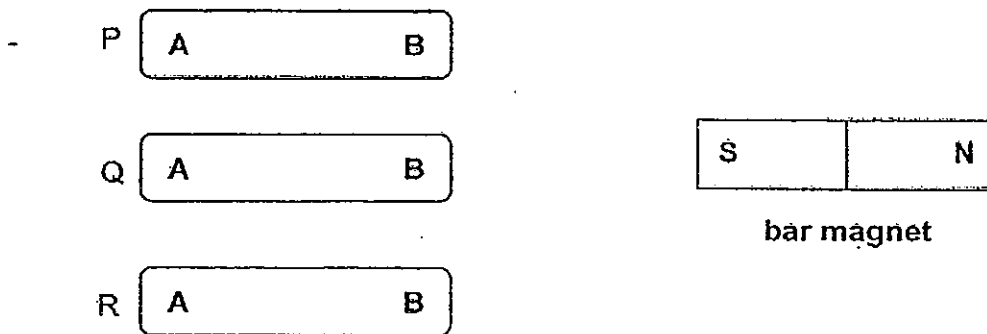

He brought the bar magnet closer to each rod and recorded his observations in the table as shown below.

Rod	Observations
P	A and B are attracted by the south pole of the magnet.
Q	B is repelled by the south pole of the magnet.
R	Remained stationary.

Based on his observations above, which of the following statements is definitely true?

- (1) Rod P is made of gold.
- (2) Rod Q is likely to be a magnet.
- (3) Rods Q and R are magnetic materials.
- (4) Rod R can be made into a temporary magnet.

27. Jeffrey hung 4 bar magnets, A, B, C and D, of different sizes at a fixed distance above trays containing identical number of iron pins as shown in the diagram below.

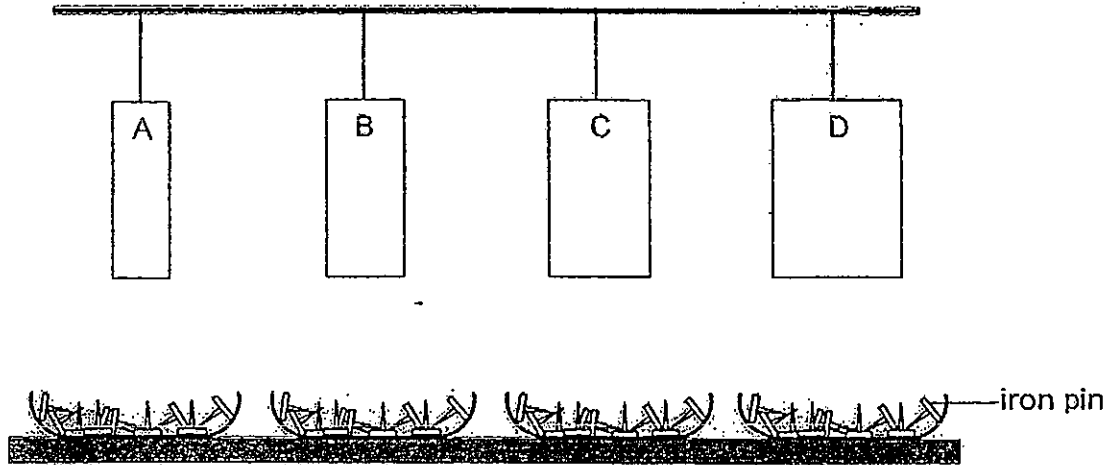

Jeffrey recorded the number of iron pins in each tray before and after the magnets were hung above the iron pins.

Magnet	Number of iron pins in the container at first	Number of iron pins in the container after magnet was hung above the iron pins
A	25	21
B	25	11
C	25	19
D	25	16

Based on the data shown above, which one of the following statement, W, X, Y and/or Z, is/are correct?

- W Magnet A has the greatest magnetic strength.
- X Magnet B has the greatest magnetic strength.
- Y Magnet D has greater magnetic strength than C but weaker magnetic strength than B.
- Z The greater the size of the magnet, the greater its magnetic strength.

- (1) W only
- (2) Z only
- (3) X and Y only
- (4) Y and Z only

28. Kelly wanted to conduct an experiment on electromagnets. She set up an experiment as shown in the diagram below. She hung a nail from an equal distance between 2 rods, A and B, which are of equal sizes.

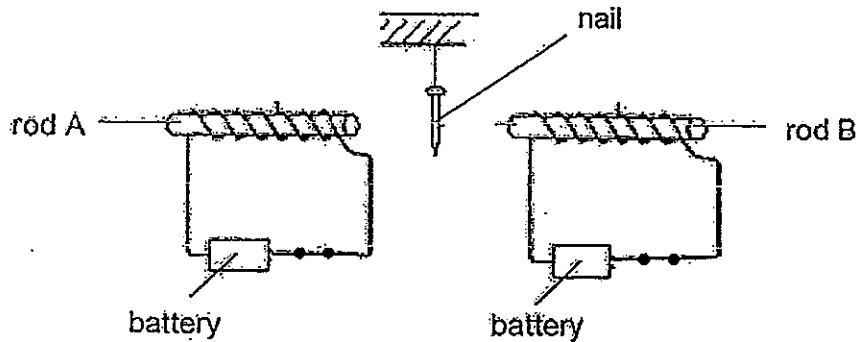

When she closed the switches, she observed that the nail moved towards rod B. All the circuits are working.

Which of the following most likely are the materials that the nail, rod A and rod B made of respectively?

	nail	rod A	rod B
(1)	iron	nickel	copper
(2)	iron	glass	nickel
(3)	steel	iron	plastic
(4)	steel	aluminium	copper

29. Ali suspended a magnet above object S and observed that object S was lifted up as shown in diagram 1. Later, he inserted object T between the magnet and object S. Diagram 2 below shows the result of the experiment.

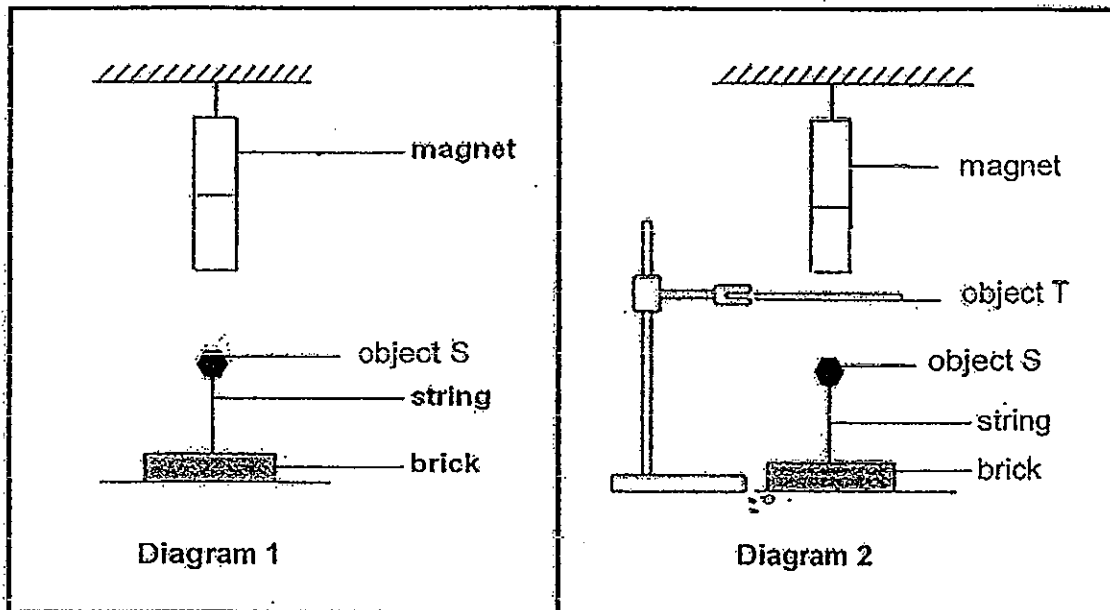

What could objects S and T most likely be made of?

	Object S	Object T
(1)	iron	plastic
(2)	plastic	steel
(3)	copper	nickel
(4)	aluminium	copper

30. The diagram below shows a two-piece device designed for cleaning both sides of a window pane at the same time.

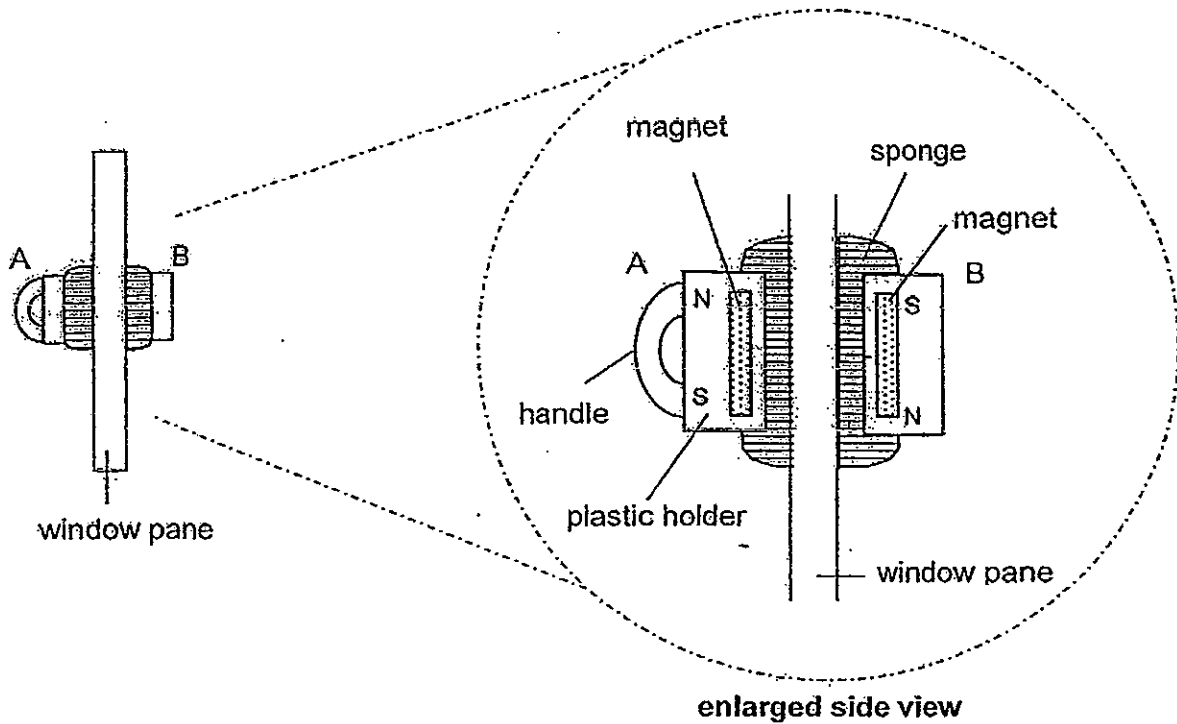

When part A moves over the inner surface of the window pane, part B follows it and moves over the outer surface. In this way, the window pane is being cleaned on both sides at the same time.

How was the device able to do this?

- A The magnets are attracted to the window pane. -
- B Magnetic force can pass through the window pane.
- C The like poles of magnets repel each other and hold the device together.
- D The unlike poles of magnets attract each other and hold the device together.

- (1) A and B only
- (2) B and D only
- (3) B, C and D only
- (4) A, B, C and D

Name : _____ Index No: _____ Class: P4 _____



SECTION B (40 marks)

For questions 31 to 44, write your answers clearly in the spaces provided.

The number of marks available is shown in brackets [] at the end of each question or part question.

31. Peter sprinkled some water on a piece of fresh bread and placed it in a sealed plastic bag. Then, he placed a piece of toasted bread in another sealed bag. He labelled them set-up A and set-up B as shown below.

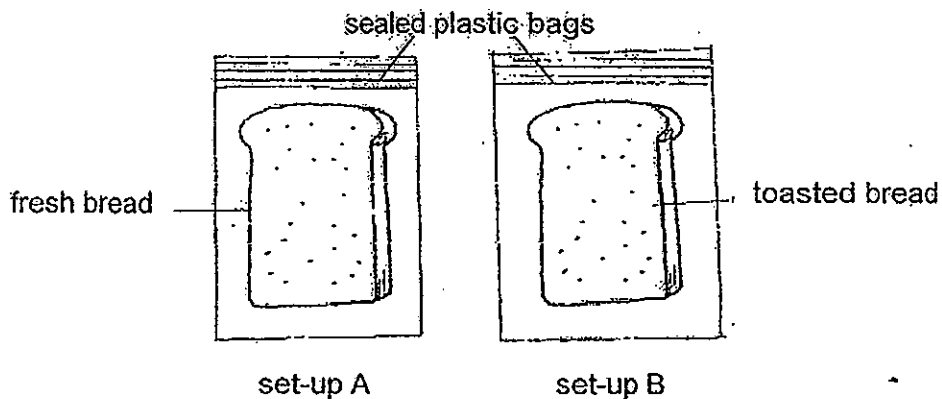

- (a) After a few days, Peter spotted some organisms on one of the slices of bread.
Which set-up, A or B, did he find the organisms growing on the bread?
Name the organisms. [1]

- (b) Peter found that the bread in the other set-up looked the same as before.
What could be a possible reason for it? [1]

- (c) Identify the variable that was changed in the above experiment. [1]

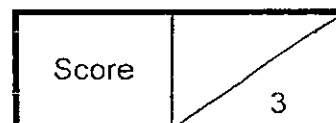

32. A classification chart of animals is shown below.

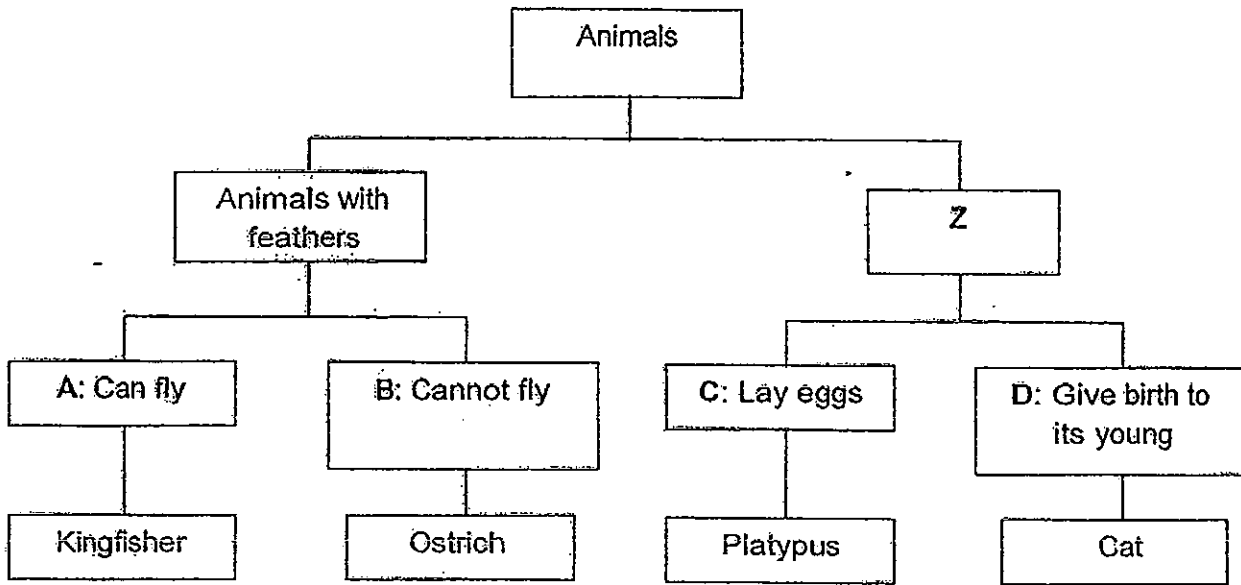

(a) Suggest an appropriate heading for Z. [1]

Z: _____

(b) Based on the chart above, what are the characteristics of the ostrich? [1]

Score	2
-------	---

33. (a) Draw the life cycle of a frog in the box provided below.

[1]

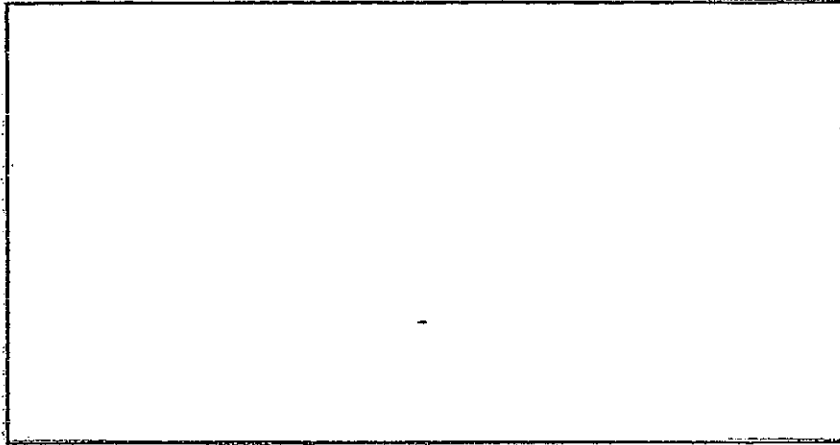

The diagram below shows the life cycle of two different insects, P and Q.

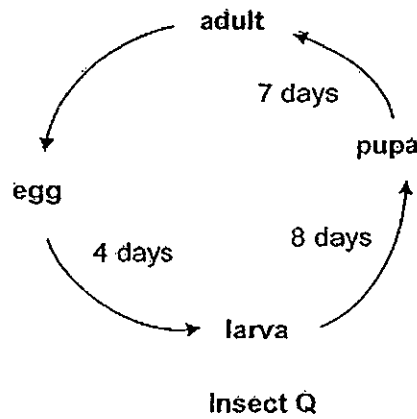
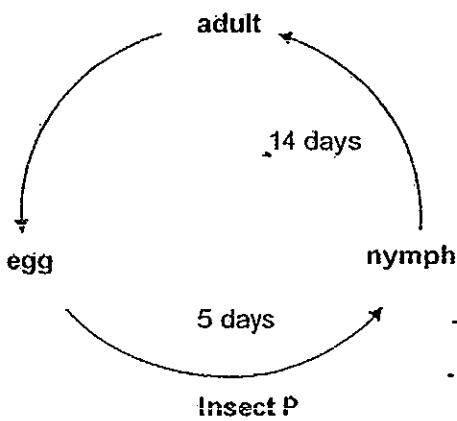

(b) Besides the egg and adult stages, state one similarity between the life cycle of Insect P and Q. [1]

(c) Name an animal that has a similar life cycle to insect P. [1]

Score	3
-------	---

34. Khalid wanted to find out which type of beans will grow the fastest. He put identical number of beans of different types into 3 containers, P, Q and R, as shown in the diagram below:

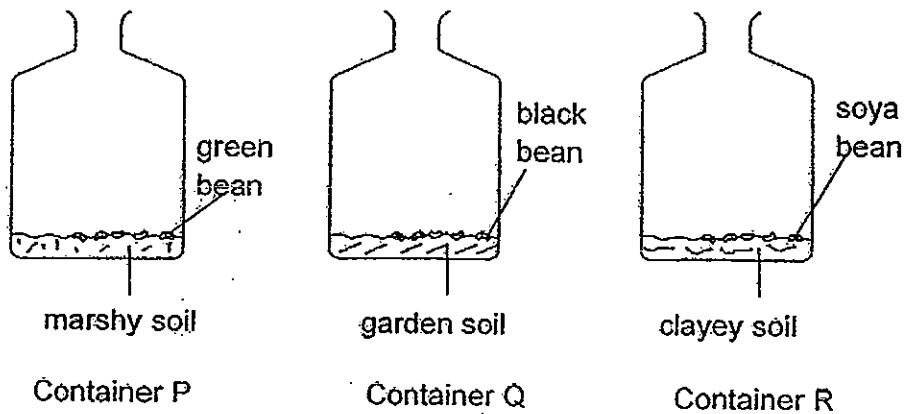

He placed all the containers near a window in a science laboratory. After 1 week, he observed that all the beans have started to grow. He then recorded the height of the seedlings.

(a) Did Khalid conduct a fair test? Explain your answer. [2]

(b) During the first week of his experiment, Susan, his classmate, commented that Khalid could place the 3 containers in a cupboard in the science laboratory and need not place the containers near the window.

Do you agree with her? State a reason for your answer. [1]

Score	3
-------	---

35. Siow Ling ate a bun. When the digestion of the bun is completed, the digested food is transported to every part of her body.

(a) Name the body system that is responsible for transporting the digested food to all parts of Siow Ling's body. [1]

(b) Name the part of the digestive system that absorbs most of the water from the undigested food? [1]

Score	2
-------	---

36. Each time the heart contracts and relaxes to pump the blood around the body, it is known as a heartbeat.

Aishah conducted an investigation to find out more about heartbeats of organisms. She tabulated her findings in the table below.

Organisms	Average Mass	Number of heartbeats per min
Live Hamster	60 g	450
Live Dog	5 kg	90
Live Elephant	5000 kg	30

- (a) Based on the results above, what is the relationship between the mass of an organism to the number of heartbeats per minute? [1]

Aishah measured her number of heartbeats for 1 minute when she was at rest. She repeated the measuring activity and recorded the readings in the table below.

Number of heartbeats in 1 minute					
Reading 1	Reading 2	Reading 3	Reading 4	Reading 5	Reading 6
78	76	45	81	77	80

- (b) Aishah made a counting error while carrying out the investigation. Identify the reading (1, 2, 3, 4 or 5) that contains the counting error. [1]
or 6

Reading: _____

- (c) Suggest the importance of repeating her investigation. [1]

Score	3
-------	---

37. Sarah carried out an experiment on two balsam plants as shown below. She poured 200 ml of water in each bottle and covered the roots of the plant in bottle Y with a plastic bag.

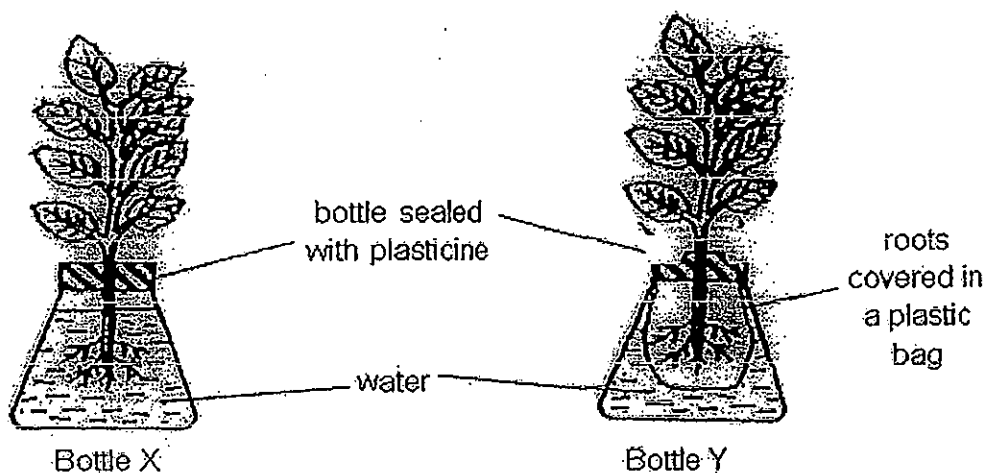

Sarah then recorded the amount of water left in both bottles X and Y after 3 days as shown in the table below.

Day	Amount of water left in Bottle X /ml	Amount of water left in Bottle Y /ml
1	195	200
2	192	200
3	188	200

- (a) What can she conclude from the results above? [1]

- (b) Explain your answer in (a). [2]

(Continue Q37 in the next page)

Score	3
-------	---

Sarah's friend, John, wants to find out if the number of leaves on the plant affect the amount of water absorbed by the plant. He used a balsam plant with eight leaves for bottle X and another balsam plant with six leaves for bottle Y as shown below.

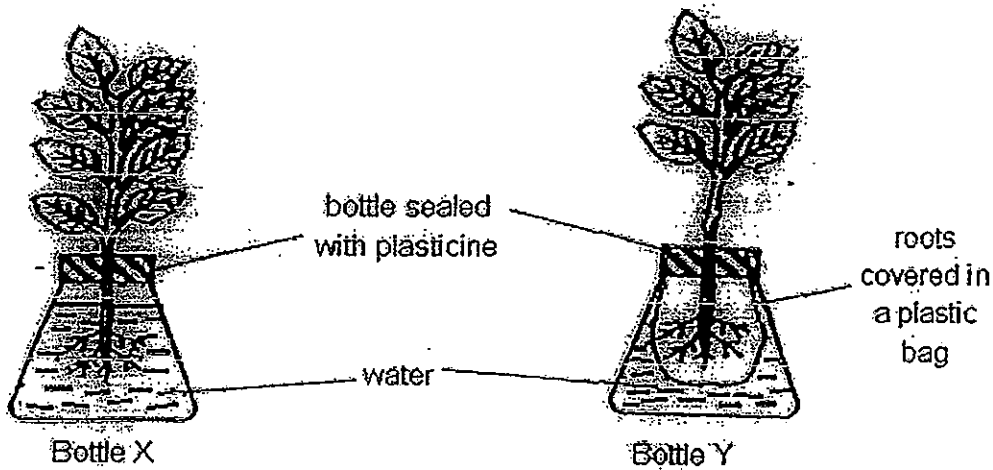

John then recorded the amount of water left in both bottle X and Y after 3 days and found out that his results are similar to Sarah's. However, Sarah said that John did not conduct a fair test.

(c) Do you agree with Sarah? Give a reason for your answer. [1]

Score	1
-------	---

38. Ahmad carried out an experiment to find out if the type of wood used would affect the strength of the plank as shown in the diagram below.

He carried out the experiment on 4 different wooden planks, A, B, C and D, respectively. He placed identical blocks on the wooden planks.

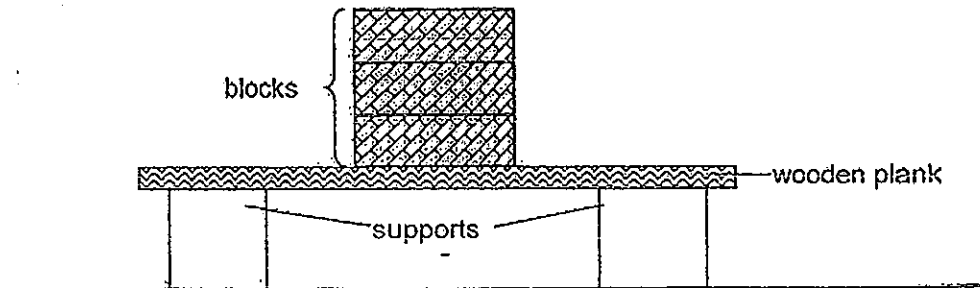

He recorded the minimum number of blocks which each wooden plank was able to withstand before it started to break.

He plotted his result on a graph as shown below.

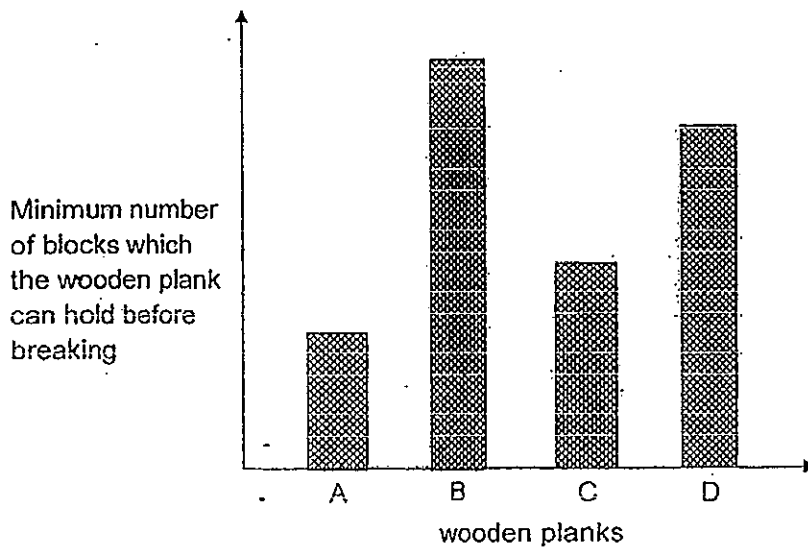

(a) Using the graph above, arrange the wooden planks, A, B, C and D, in order according to their strength. [1]

Weakest \longrightarrow Strongest

(Continue Q38 in the next page)

Score	1
-------	---

(b) Put a tick (✓) in the box(es) the variable(s) that Ahmad must keep constant in order to conduct a fair test.

[1]

Variables	To keep constant
Type of wood used	
Thickness of each plank	
Material of each block used	

(c) Ahmad's classmate, Linda, mentioned that Ahmad could use the information from the graph above to find out which one of the 4 types of wood tested is the hardest.

Do you agree with Linda? Give a reason for your answer.

[1]

Score	2
-------	---

- 39: Kim Seng hangs 2 balloons of the same size on the two ends of a lever balance as shown below. He then pierces balloon Q with a needle and deflates it completely.

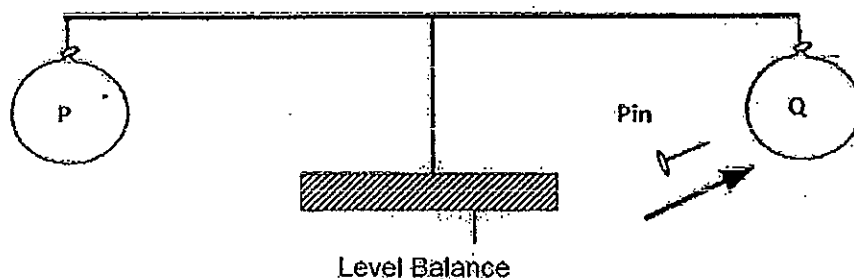

- (a) Complete the diagram below and draw how the lever balance would look like after balloon Q has been deflated completely. Label the balloons, P and Q. [1]

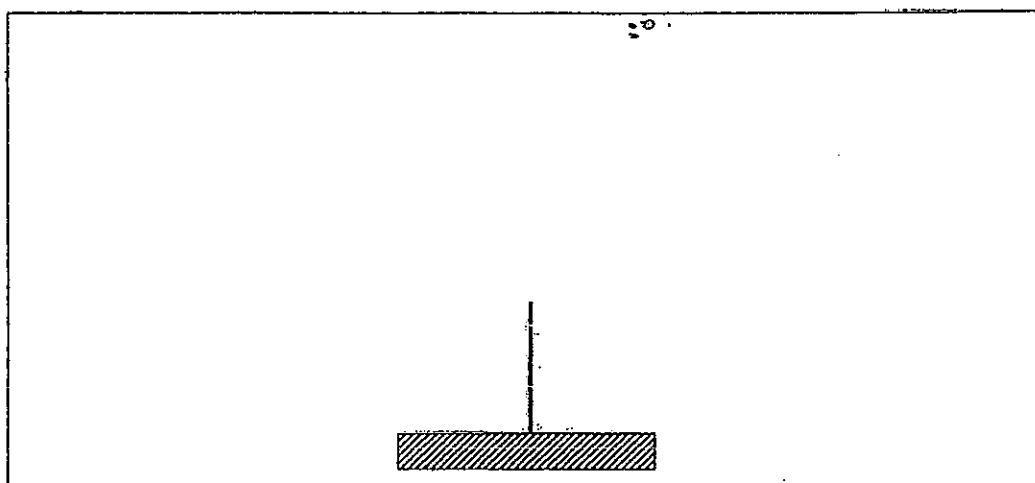

- (b) What does this experiment tell you about the property of air? [1]

Score	2
-------	---

40. Two syringes, P and Q, contain water and substance X respectively. One end of each syringe is sealed.

Plunger in syringe P could **NOT** be pushed in while plunger in syringe Q could be pushed in as shown in the diagram below.

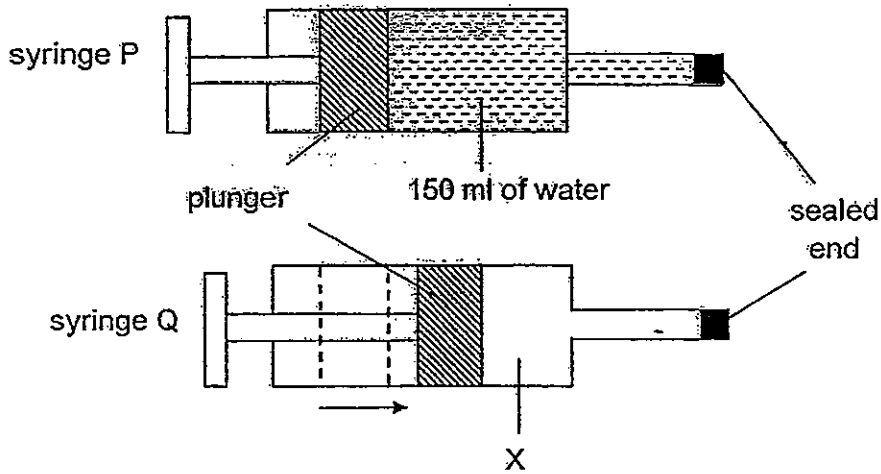

- (a) What is most likely to be the state of matter of substance X? [1]

Substance X : _____ state

- (b) Give a reason for your answer in (a). [1]

- (d) The water in syringe P is poured into a container as shown below. DRAW a line to show the water level in part A and B of the container respectively. The water level in part C of the container has been drawn for you. [1]

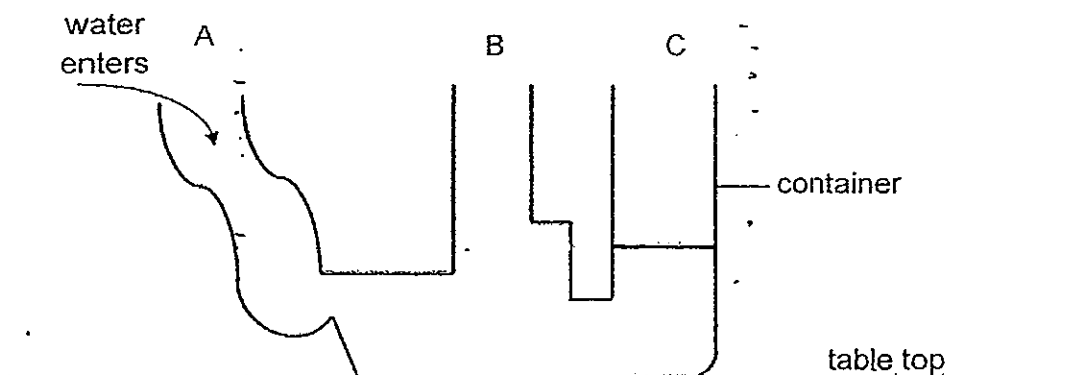

Score	3
-------	---

41. Aini placed a funnel on a beaker and poured some water in the funnel as shown below.

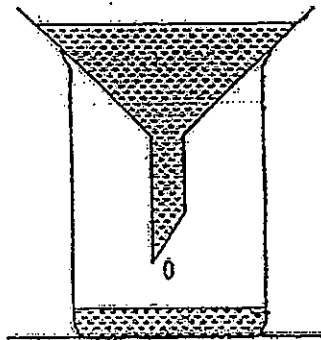

She realised that the water flowed very slowly into the beaker as shown above.

- (a) What can Aini do to allow the water in the funnel to flow into the beaker faster, without changing the apparatus or having any new addition to the set-up? [1]

- (b) Explain your answer in (a). [2]

Score	3
-------	---

42. Sam filled a measuring cylinder with 15 cm^3 of water. He then dropped a metal cube into the measuring cylinder as shown below.

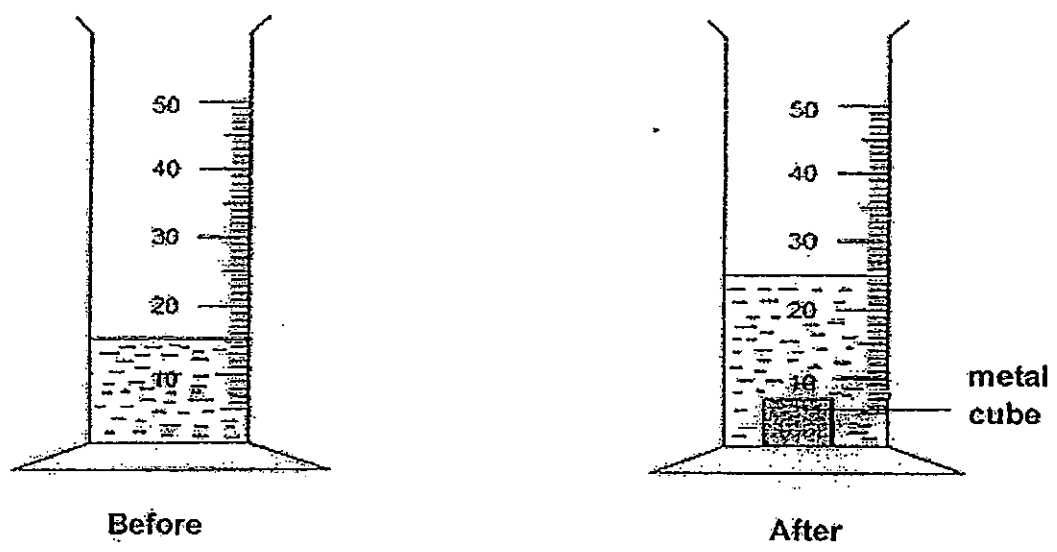

- (a) Give a reason why the water level rose up when the metal cube was put in the measuring cylinder. [1]

(Continue Q42 in the next page)

Score	1
-------	---

Sam needed to fill a fish tank with water up to point A in order to keep his fish. He decided to use some pebbles to reduce the amount of water needed to fill the tank to point A. He bought some pebbles and a fish tank as shown below.

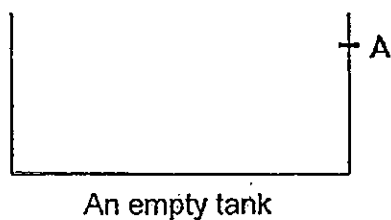

(b) Describe how Sam can use the pebbles to achieve his aim. [1]

(c) Give a reason for your answer above. [1]

Score	2
-------	---

43. Gopal placed metal rings A, B, C and D on top of each other in three different arrangements, as shown in the diagrams below.

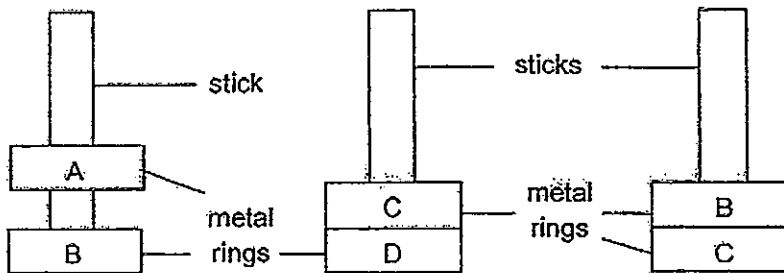

- (a) Based on the diagrams above, which ring(s) can Gopal confidently conclude is/are a magnet? [1]

- (b) Explain your answer in (a). [1]

- (c) Name a material that can be used to make the metal ring(s) you have stated in (a). [1]

Score	3
-------	---

44. The diagram below shows three bar magnets, 1, 2 and 3. Magnets 2 and 3 are held in place and magnet 1 is brought near to them.

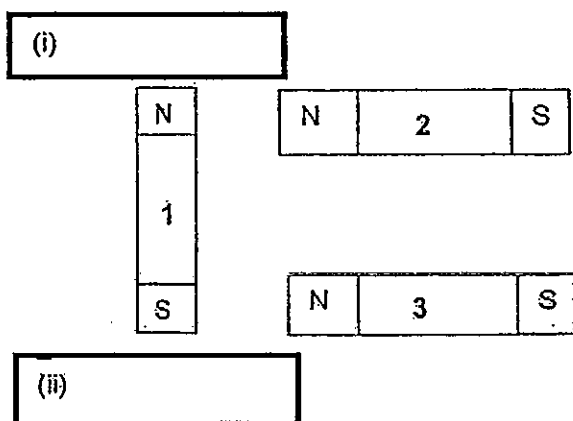

- (a) How will magnet 1 move? **DRAW** arrows in the boxes, in the diagram above, to show how it will move. [1]

The diagram below shows a steel object placed in between two set-ups, A and B. Identical batteries, wires and iron nails were used.

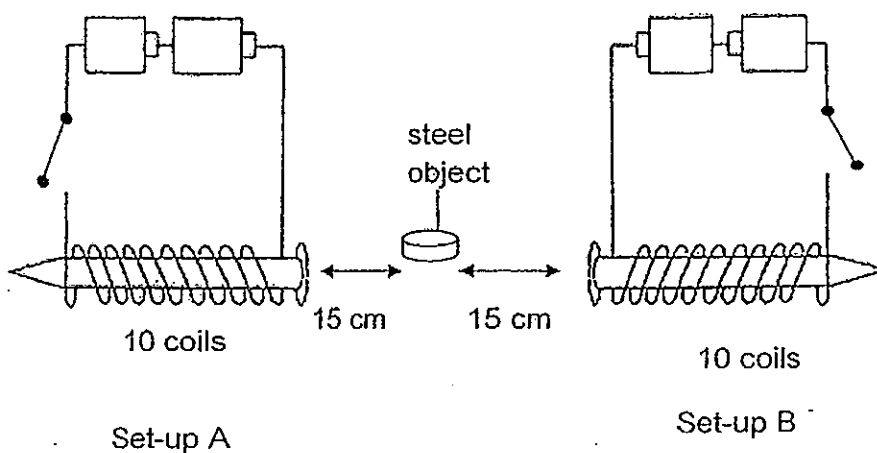

When both switches were closed, the steel object remained in the same position.

(Continue Q44 in the next page)

Score	1
-------	---

The experiment was repeated with different number of coils round the nails in set-ups A and B. The results were recorded in the table below.

Number of coils in set-up A	Number of coils in set-up B	Observations on steel object
10	20	move towards iron nail in set-up B
20	10	move towards iron nail in set-up A
10	10	remain in the same position

- (b) Predict the direction in which the steel object will move towards when the number of coils in set-up A is 40 and the number of coils in set-up B is 60. Explain your prediction. [2]

The steel object will move towards iron nail in set-up _____

Explanation:

End-of-paper

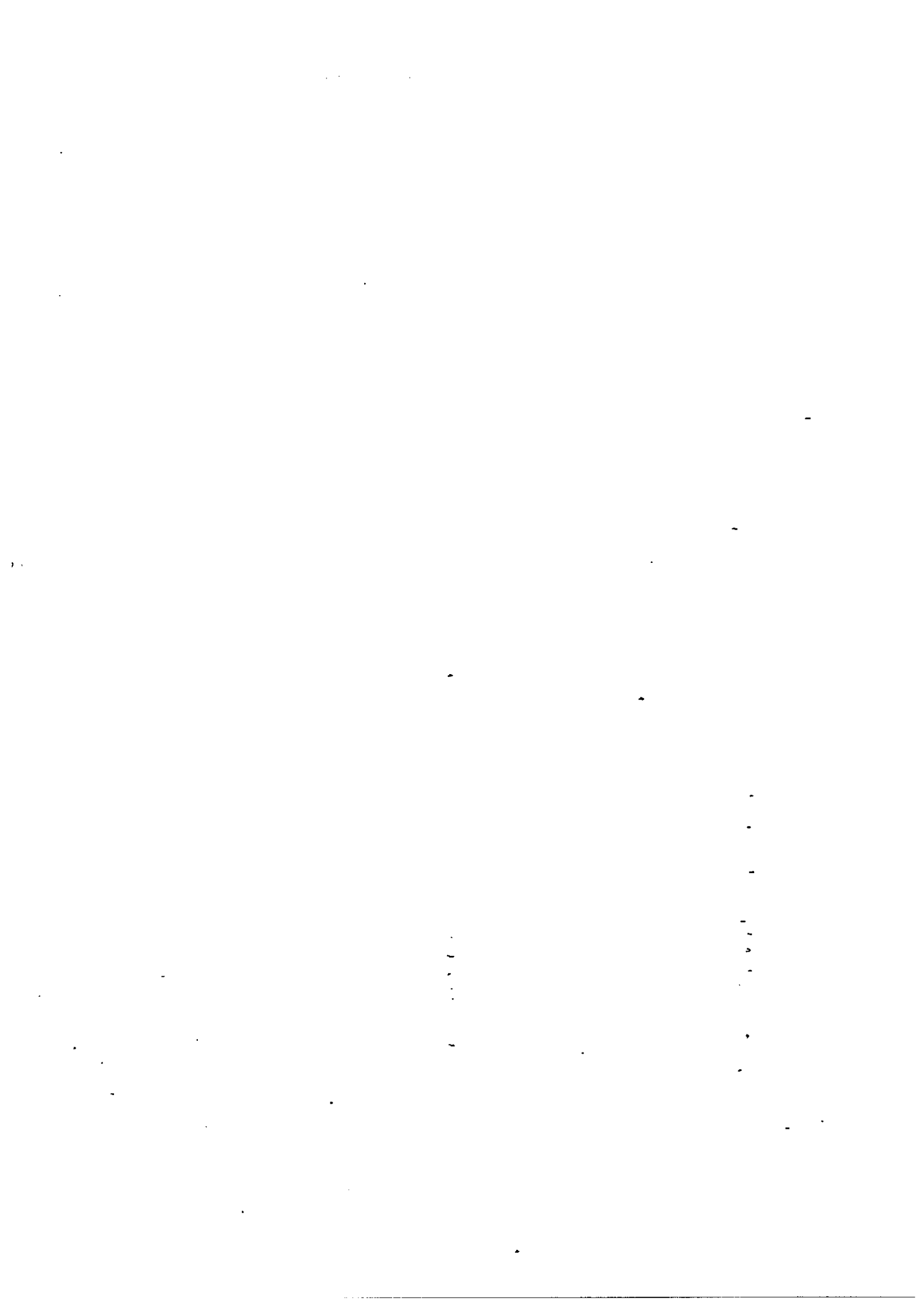

ANSWER SHEET

EXAM PAPER 201

SCHOOL : RAFFLES GIRLS'
SUBJECT : PRIMARY 4 SCIENCE

TERM : SA1

Q1	Q2	Q3	Q4	Q5	Q6	Q7	Q8	Q9	Q10	Q11	Q12	Q13	Q14	Q15	Q16	Q17
3	2	3	3	2	4	2	2	2	3	2	4	4	4	1	3	4

Q18	Q19	Q20	Q21	Q22	Q23	Q24	Q25	Q26	Q27	Q28	Q29	Q30
3	4	3	1	5	2	2	3	2	3	2	1	2

31)a) He will find mould on the fresh bread in Set-up A.

b) The bread was toasted and wasn't damp anymore, whereas for fresh bread, it is damp and mould grows on cool and damp places, so the bread in set-up B remained the same.

c) The type of bread was different, the bread in Set-up A was fresh and some water on it while the bread in Set-up B was toasted.

32)a) Z : Animals with Hairs.

b) It has feathers and can fly.

33)a)

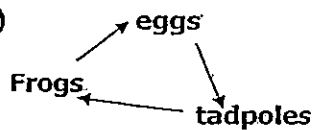

b) It takes 19 days for the egg to hatch to an adult.

c) Cockroach.

34)a) No. The type of soil was different. In order to see which bean grows faster he should just change the type of bean and the rest of the things must be the same.

b) Yes. During germination the seed does not need sunlight for food, it gets its own food from the seed leaf, so it need not be placed at the window.

- 35) a) Circulatory system.
 b) Large intestine.

- 36) a) The heavier the Organism is, the lesser the number of heart beats per min is.
 b) 3
 c) To ensure the test is reliable.

- 37) a) Roots absorb water.
 b) The amount of the water in Bottle X decreased; this show that the roots take in water. However, in Bottle Y, the roots were wrapped up in a plastic bag, it is not able to take in any water, Thus, the amount of water remains the same.
 c) Yes. The roots of the plant in Bottle Y was covered with a plastic bag and it can't absorb water.

- 38) a) A C D B
 b) Thickness of each plank. / Material of each block used.
 c) No. The test above is to test the strength but Ahmad wants to tested which is hardest.

39) a)

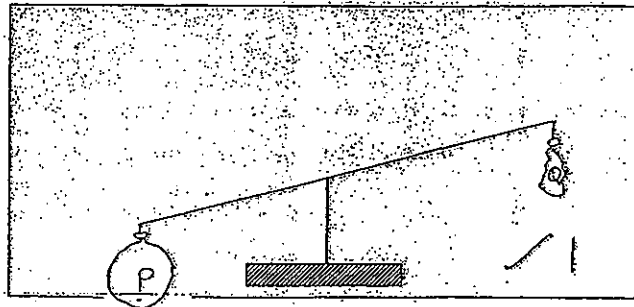

- b) Air have mass.

40) a) gaseous

- b) Air can be compress and x can be also compress, there for, X is air.
 d)

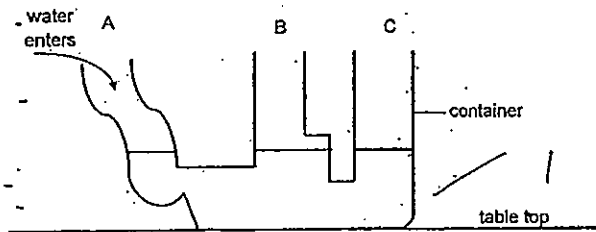

41)a)She can hold the funnel up.

b)Lifting up the funnel allow air in the beaker to escape, thus allowing the water to occupy, the space previously occupied by the air.

42)a)The metal cube occupy space in the water so the water level rose up.

b)He can put the pebbles in the tank than filled the water up to point A.

c)The pebbles occupied space so he would not need to used so much water.

43)a)A and B.

b)Only like poles of magnet can repel each other. A is floating above B, they are repelling each other, thus A and B are magnet.

c)Steel.

44)a)i) ←

ii) →

b)B.

The more number of coil there are, the steel object will move towards it, so if B has 60 soil and A has 40, the steel object will move towards B.

0.