



**RAFFLES GIRLS' PRIMARY SCHOOL  
SEMESTRAL ASSESSMENT 1  
MATHEMATICS (PAPER 1)  
PRIMARY 5**

Name: \_\_\_\_\_ ( )

Form Class: P5 \_\_\_\_\_

Banded Math Class: P5 \_\_\_\_\_

Date: 9 May 2013

Duration: 50 min

<b>Your Score (Out of 100 marks)</b>	
<b>Your Score (Out of 40 marks)</b>	
<b>Parent's Signature</b>	

**INSTRUCTIONS TO CANDIDATES**

1. Do not turn over this page until you are told to do so.
2. Follow all instructions carefully.
3. Answer **ALL** questions and show all working clearly.
4. **NO** calculator is allowed for this paper.

**SECTION A (20 marks)**

Questions 1 to 10 carry 1 mark each. Question 11 to 15 carry 2 marks each. For each question, four options are given. One of them is the correct answer. Make your choice (1, 2, 3 or 4). Shade your answer (1, 2, 3 or 4) on the OAS provided. All diagrams are not drawn to scale.

---

1. In 803 762, the digit 8 is in the \_\_\_\_\_ place.

- (1) hundreds
- (2) thousands
- (3) ten thousands
- (4) hundred thousands

2.  $288 \times 5 = 188 \times 5 + 200 \times 5 - \underline{\hspace{2cm}} \times 5$

- (1) 10
- (2) 50
- (3) 100
- (4) 500

3. What is the volume of the cuboid shown?

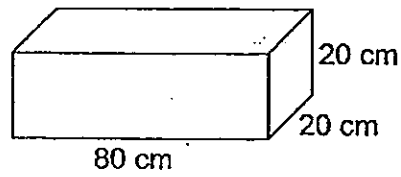

- (1)  $120 \text{ cm}^3$
- (2)  $320 \text{ cm}^3$
- (3)  $16\,00 \text{ cm}^3$
- (4)  $32\,000 \text{ cm}^3$

4.  $\frac{6}{9} = \frac{\square}{12}$  What is the missing number in the box?

- (1) 8
- (2) 2
- (3) 3
- (4) 9

5. Express  $\frac{38}{7}$  as a mixed number. The answer is \_\_\_\_\_.

- (1)  $3\frac{5}{7}$
- (2)  $4\frac{1}{7}$
- (3)  $5\frac{3}{7}$
- (4)  $7\frac{3}{5}$

6. Which unit shape is used for the tessellation below?

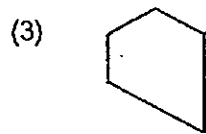
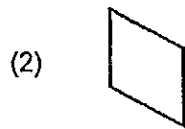
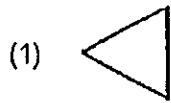
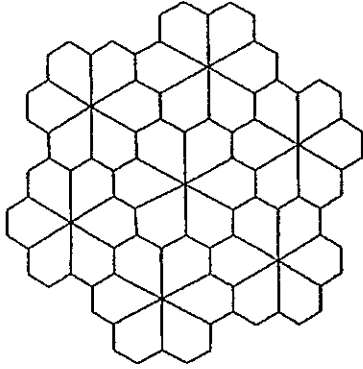

7. Find the product of 42 thousandths and 9 ones.

(1) 0.378

(2) 3.78

(3) 37.8

(4) 378

8. Express 3.25 as a mixed number in its simplest form.

(1)  $3\frac{1}{4}$

(2)  $3\frac{25}{100}$

(3)  $3\frac{2}{5}$

(4)  $3\frac{1}{25}$

9. 30 ml of mango syrup is mixed with 150 ml of water to make a glass of mango drink. Using this ratio, how much water is needed when 200 ml of mango syrup is used?

(1) 50 ml

(2) 60 ml

(3) 1000 ml

(4) 1200 ml

10. The length of a pole when rounded off to the nearest metre is 2 m.  
Which of the following could be the actual length of the pole?

- (1) 1m 12 cm
- (2) 1m 18 cm
- (3) 2m 15 cm
- (4) 2m 99 cm

11. What is the total shaded area in the figure below?

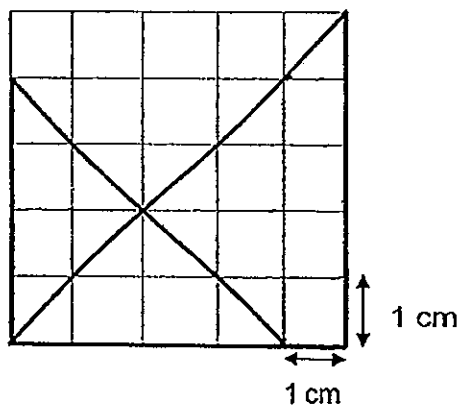

- (1)  $8.5 \text{ cm}^2$
- (2)  $12.5 \text{ cm}^2$
- (3)  $16.5 \text{ cm}^2$
- (4)  $20.5 \text{ cm}^2$

12. Which one of the following shape has no line of symmetry?

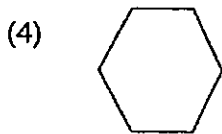
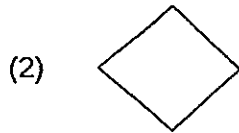

13. The diagram below shows a piece of torn paper.  
In which column is the number 37 written?

A	B	C	D
2	3	4	5
6	7	8	9
10	11	12	13
14	15		

(1) A

(2) B

(3) C

(4) D

14. The solid below is made up of some identical 1-cm cubes.  
What is the volume of the solid?

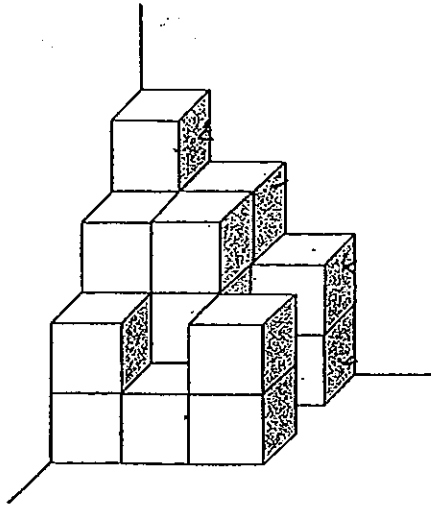

- (1)  $12 \text{ cm}^3$   
(2)  $13 \text{ cm}^3$   
(3)  $20 \text{ cm}^3$   
(4)  $21 \text{ cm}^3$
15. Tom gave  $\frac{2}{5}$  of his money to his mother. He then used \$120 to buy some books and had  $\frac{1}{2}$  of his money left. How much money did he have at first?
- (1) \$300  
(2) \$600  
(3) \$1080  
(4) \$1200



**SECTION B (20 marks)**

Questions 16 to 25 carry 1 mark each. Write your answers in the spaces provided. For questions which require units, give your answers in the units stated. All diagrams are not drawn to scale. Answers in fractions or ratio must be expressed in the simplest form.

---

16. Form the smallest 5-digit even number with the following digits.

6, 9, 8, 5, 1

Ans: \_\_\_\_\_

17.  + 5 hundredths = 1.73

Express your answer in decimals.

Ans: \_\_\_\_\_

18. The tank below has a square base of side 10cm.  
The shaded area is  $120 \text{ cm}^2$ .  
What is the volume of the tank?

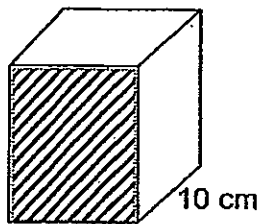

Ans: \_\_\_\_\_  $\text{cm}^3$

19. Draw the line of symmetry for the diagram shown below.

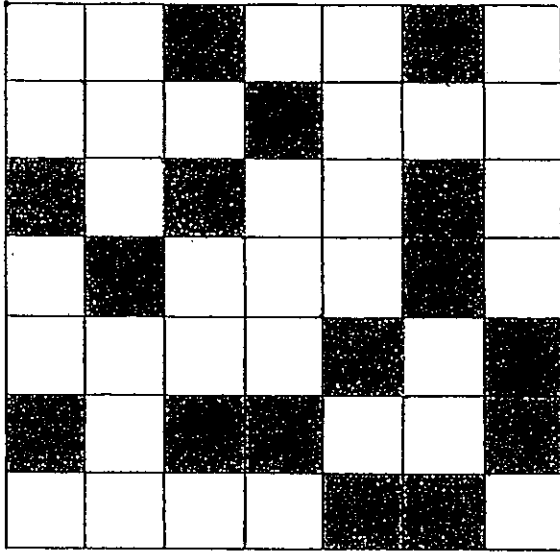

20. The pattern in the box below shows a part of a tessellation.  
Extend the tessellation by drawing 2 more unit shapes within the box.

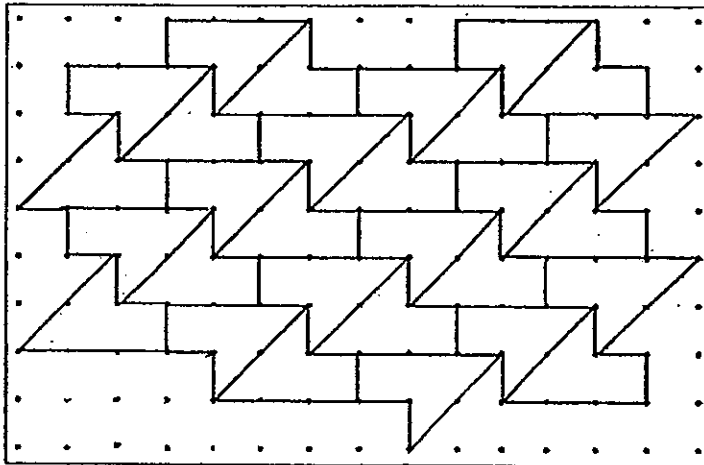

21. Sally had  $8\frac{2}{5}$  kg of flour. She used  $3\frac{3}{4}$  kg of the flour to make a cake.

How much flour had she left?

Ans: \_\_\_\_\_ kg

22. Express  $1\frac{1}{7}$  as a decimal, correct to 2 decimal places.

Ans: \_\_\_\_\_

23. Gina bought 5 cupcakes at \$2.85 each.  
She gave the cashier \$50.  
How much change did she receive?

Ans:\$ \_\_\_\_\_

24. Jenna jogged a total distance of 19.25 km in a week.  
She jogged the same distance every day.  
How far did she jog each day?

Ans: \_\_\_\_\_ km

25. Shade the 2 unit shapes that are wrongly tessellated in the diagram below.

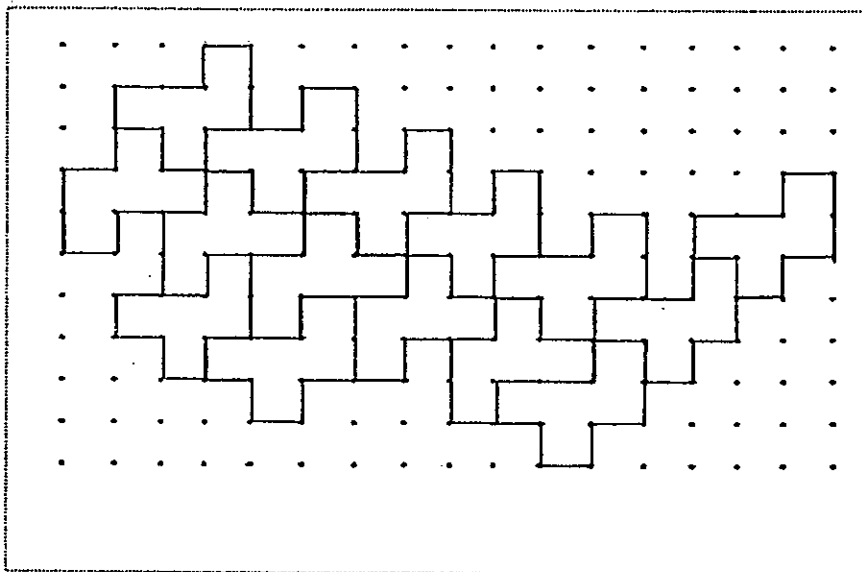

Questions 26 to 30 carry 2 marks each. Show your working clearly in the space provided for each question and write your answers in the space provided. For questions which require units, give your answers in the units stated. All diagrams are not drawn to scale. Answers in fractions or ratio must be expressed in the simplest form.

---

26. Arrange the following fractions in descending order:

$$\frac{1}{2}, \frac{7}{8}, \frac{1}{4}, \frac{5}{12}$$

Ans: \_\_\_\_\_

27. Find the value of

$$210 - 400 \div 5 + 120 \div 4$$

Ans: \_\_\_\_\_

28. Tank A is  $\frac{2}{3}$  filled with water.  
 What is the amount of water in Tank A?

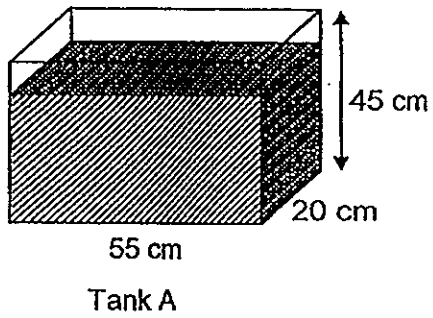

Ans: \_\_\_\_\_ cm<sup>3</sup>

29. How many more squares should be shaded such that the ratio of the number of shaded squares to the number of unshaded squares is 1 : 4?

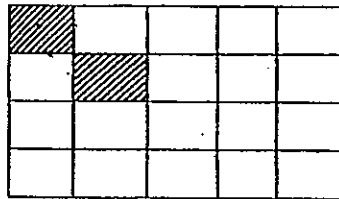

Ans: \_\_\_\_\_

30. A tank is filled with  $3200 \text{ cm}^3$  of water.  
The area of rectangular surfaces X, Y and Z is  $100 \text{ cm}^2$  each.  
What is the height of the water in the tank?

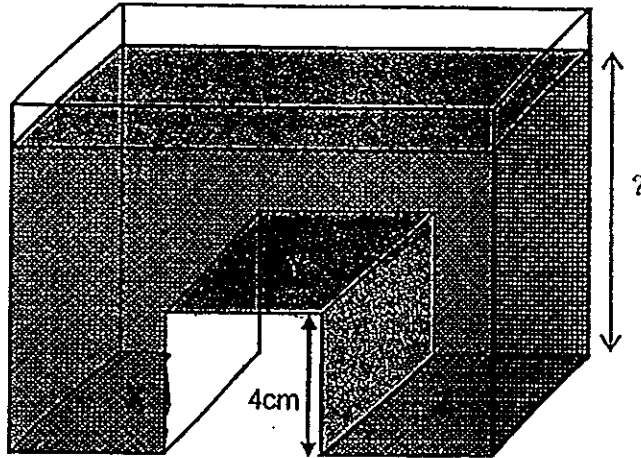

Ans: \_\_\_\_\_ cm

End of Paper-  
☺ Please check your work carefully ☺

Setters: Ms Lee S. K.  
Ms Lim L. S.  
Ms Luo Z. Q.



**RAFFLES GIRLS' PRIMARY SCHOOL  
SEMESTRAL ASSESSMENT 1  
MATHEMATICS (PAPER 2)  
PRIMARY 5**

Name: \_\_\_\_\_ ( )

Form class: P5 \_\_\_\_\_

Banded Math Class: P5 \_\_\_\_\_

Date: 9 May 2013

Duration: 1 h 40 min

<b>Your Score (Out of 60 marks)</b>	
---	--

**INSTRUCTIONS TO CANDIDATES**

1. Do not turn over this page until you are told to do so.
2. Follow all instructions carefully.
3. Answer **ALL** questions and show all working clearly.
4. The use of calculator is allowed for this paper.



Questions 1 to 5 carry 2 marks each. Show your working clearly in the space provided for each question and write your answers in the spaces provided.

Figures are not drawn to scale.

For questions which require units, give your answers in the units stated. (10 marks)

---

1. A box weighs 99 kg when it is completely filled with sand.  
It weighs 84 kg if  $\frac{2}{9}$  of the sand is removed.  
Find the mass of the sand.

Ans: \_\_\_\_\_ kg [2]

2. When a number is divided by 3, the remainder is 1.  
When the same number is divided by 4, the remainder is 3.  
What is the smallest possible number?

Ans: \_\_\_\_\_ [2]

3. Jallene has 3 boxes of sweets. Box A contains thrice as many sweets as Box B.  
Box A contains twice as many sweets as Box C. Box C contains 58 more sweets than Box B. How many sweets are there in Box A?

Ans: \_\_\_\_\_ [2]

4. Grace and Andy shared some money in the ratio 7 : 11.  
 After each of them spent \$22, the ratio of Grace's money to Andy's  
 money is 5 : 9. Find the amount of money Grace had at first.

Ans: \$ \_\_\_\_\_ [2]

5. The area of the shaded part ABCD is  $62\text{cm}^2$ .  
 Find the area of triangle ABC, given that DX is  $\frac{1}{3}$  of BY.

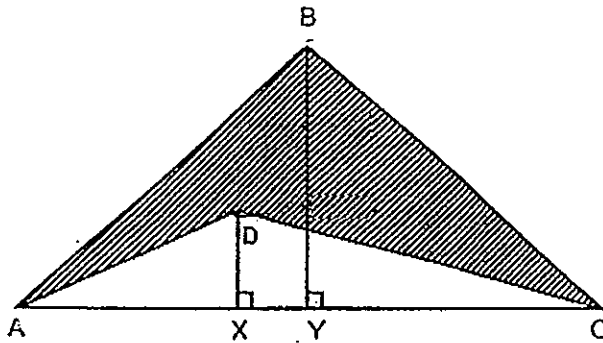

Ans: \_\_\_\_\_  $\text{cm}^2$  [2]

For questions 6 to 18, show your working clearly in the space provided for each question and write your answers in the spaces provided. Figures are not drawn to scale. The number of marks available is shown in the brackets [ ] at the end of each question or part-question. (50 marks)

---

6. A tank contains three 2-cm cubes.  
3.6 litres of water is needed to fill the tank to its brim.  
What is the base area of the tank?

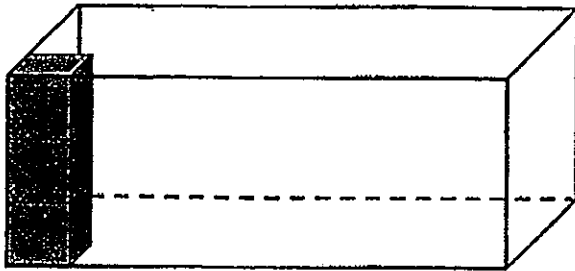

Ans: \_\_\_\_\_ [3]

7. There were some apples in basket A, B and C.  
The ratio of the number of apples in basket A to the number of apples in basket B and C was 3 : 4.  
The ratio of the number of apples in basket B to the number of apples in basket A and C was 1 : 4.  
There were 22 less apples in basket C than in basket A.  
Find the total number of apples in all the three baskets.

Ans: \_\_\_\_\_ [3]

8. Study the figure shown below. Find the area of the shaded part.

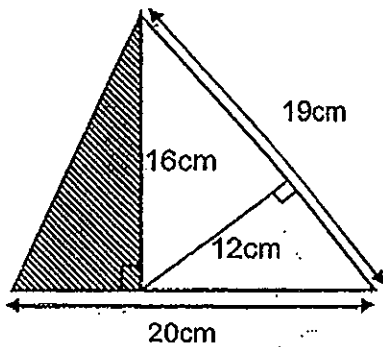

Ans: \_\_\_\_\_ [3]

9. Mr Ong could buy 80 shirts with all his money. If the price of each shirt was reduced by \$12, he would be able to buy 30 more shirts.  
How much money did Mr Ong have?

Ans: \_\_\_\_\_ [4]

10. The tables and chairs in a restaurant are arranged as shown below.

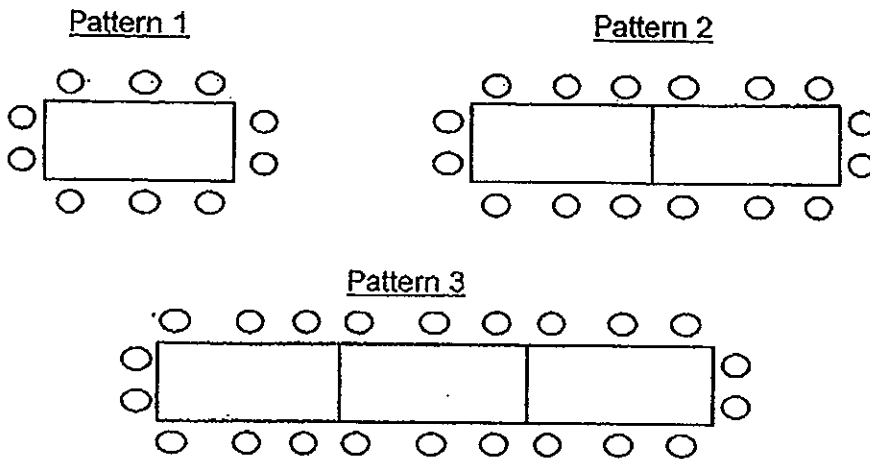

- (a) How many chairs will there be in Pattern 5?
- (b) Which pattern will have 100 chairs?

Ans : (a) \_\_\_\_\_ [2]

(b) \_\_\_\_\_ [2]

11. A carpenter removed a section of the wooden block such that it has a hollow centre going through from one end to the other as shown below.

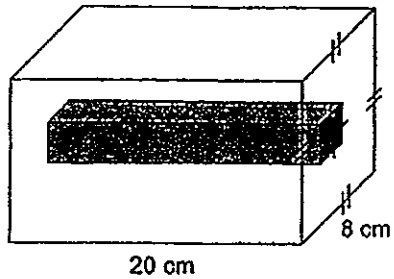

Wooden block with hollow centre

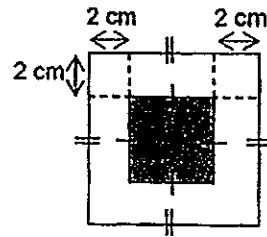

Side view of wooden block

What is the volume of the remaining wooden block?

Ans: \_\_\_\_\_ [4]

12. James and Nick had a total of \$4862.  
James spent  $\frac{1}{7}$  of his money while Nick spent  $\frac{2}{5}$  of his money.  
They had an equal amount of money left.  
How much money did Nick spend?

Ans: \_\_\_\_\_ [3]



13. The figure below is made up of 2 squares, PQUV and RSTU. VU is 16 cm and UT is 12 cm. Find the area of the shaded part.

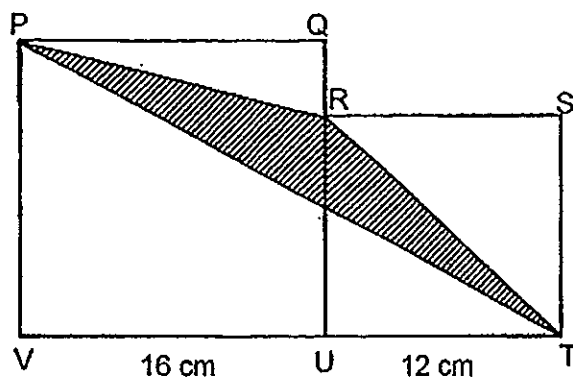

Ans: \_\_\_\_\_ [4]

14. Joseph brought some money for travelling. He spent  $\frac{2}{5}$  of his money on T-shirts and  $\frac{1}{3}$  of his money on shoes. He then gave \$180 to his brother to pay for the food. He had \$948 left. How much money did he bring for travelling?

Ans: \_\_\_\_\_ [4]

15. At a confectionary, Mr Ong sold half of his buns and another 300 more buns in the first hour. In the second hour, he sold  $\frac{1}{4}$  of the remaining buns.

If 864 buns were left in the end, how many buns were there at first?

Ans : \_\_\_\_\_ [4]

16. The cost of a blouse was  $\frac{3}{4}$  of a dress. June bought 3 blouses and 2 dresses and paid a total of \$280.50.

(a) What was the cost of 1 dress?

(b) How much did she spend if she bought 9 blouses and 6 dresses?

Ans: (a) \_\_\_\_\_ [2]

(b) \_\_\_\_\_ [2]

17. Four children shared a sum of money equally.

Greg gave  $\frac{1}{3}$  of his money to Tom.

Tom then gave  $\frac{1}{7}$  of his money to Carl.

Carl then gave  $\frac{3}{5}$  of his money and \$50 to Mary.

Mary had \$770 in the end.

(a) How much money did each child have at first?

(b) How much money did Tom have in the end?

Ans: (a) \_\_\_\_\_ [3]

(b) \_\_\_\_\_ [2]

18. June bought 5 similar pencil cases and 8 similar key chains.  
Each pencil case cost \$1.35 more than a key chain.

If the total cost of the key chains was \$14.85 more than the total cost of the pencil cases,

- (a) how much did 1 pencil case cost?  
(b) how much did June spend altogether?

Ans: (a) \_\_\_\_\_ [3]

(b) \_\_\_\_\_ [2]

**-End of Paper-**  
**Please check your work carefully ©**

Setters: Ms Lee S. K.  
Ms Lim L. S.  
Ms Luo Z. Q.

# ANSWER SHEET

EXAM PAPER 2013

SCHOOL : RAFFLES GIRLS'

SUBJECT : PRIMARY 5 MATHEMATICS

TERM : SA1

Q1	Q2	Q3	Q4	Q5	Q6	Q7	Q8	Q9	Q10	Q11	Q12	Q13	Q14	Q15
4	3	4	1	3	3	1	1	3	3	2	1	4	3	4

16) 15698

17) 1.68

18) 1200cm<sup>3</sup>

19)

20)

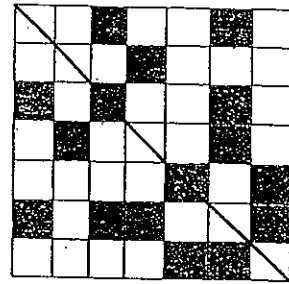
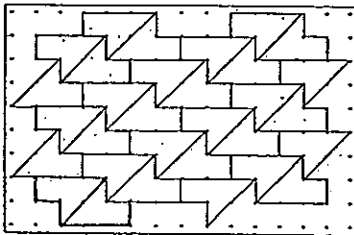

21) 4 13/20kg

22) 1.14

23) \$35.75

24) 2.75

25)

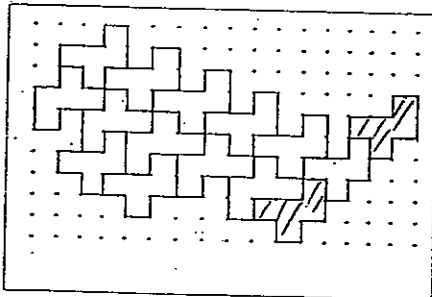

$26) 7/8, 1/2, 5/12, 1/4$

$27) 160$

$28) 33000\text{cm}^3$

$29) 2$

$30) 12\text{cm}$

Paper 2

$1) 99 - 84 = 15$

$15 \div 2 = 7.5$

$7.5 \times 9 = 67.5\text{kg}$

$2) 7$

$3) 3 - 2 = 1$

$1u \rightarrow 58$

$6u \rightarrow 58 \times 6 = 348$

$4) 11 - 9 = 2$

$7 - 5 = 2$

$2u \rightarrow 22$

$1u \rightarrow 11$

$7u \rightarrow \$77$

$5) 3 - 1 = 2$

$62 \div 2 = 31$

$31 + 62 = 93\text{cm}^2$

$6) 3.6\text{L} = 3600\text{cm}^3$

$2 \times 2 \times 2 = 8$

$3 \times 8 = 24$

$3600 + 24 = 3624$

$3624 \div 6 = 604\text{cm}^2$

$7) 15 - 13 = 2$

$2u \rightarrow 22$

$1u \rightarrow 11$

$15 + 7 + 13 = 35$

$35u \rightarrow 11 \times 35 = 385$

$8) 1/2 \times 19 \times 12 = 114$

$1/2 \times 16 \times 20 = 160$

$160 - 114 = 46\text{cm}^2$

$9) 80 \times 12 = 960$

$30 \text{ shirts} \rightarrow 960$

$1 \text{ shirt} \rightarrow 960 \div 30 = 32$

$32 \times (80 + 30) = \$3520$



10)a)  $5 - 3 = 2$

$2 \times 6 = 12$

$22 + 12 = 34$

b)  $100 - 22 = 78$

$78 \div 6 = 13$

$13 + 3 = 16$

11)  $8 \times 8 \times 20 = 1280$

$4 \times 4 \times 20 = 320$

$1280 - 320 = 960\text{cm}^3$

12) J left  $\rightarrow 6/7$

N left  $\rightarrow 3/5 = 6/10$

J  $\rightarrow 7u$

N  $\rightarrow 10u$

$17u \rightarrow 4862$

$1u \rightarrow 4862 \div 17 = 286$

$4u \rightarrow 286 \times 4 = \$1144$

13) A  $\rightarrow 16 + 12 = 28$

$\frac{1}{2} \times 28 \times 16 = 224$

B  $\rightarrow \frac{1}{2} \times 4 \times 16 = 32$

D  $\rightarrow \frac{1}{2} \times 12 \times 12 = 72$

$224 + 32 + 72 = 328$

$16 \times 16 = 256$

$12 \times 12 = 144$

$144 + 256 = 400$

$400 - 328 = 72\text{cm}^2$

14)  $180 + 948 = 1128$

$4u \rightarrow 1128$

$1u \rightarrow 282$

$15u \rightarrow 282 \times 15 = \$4230$

15)  $3u \rightarrow 864$

$1u \rightarrow 288$

$4u \rightarrow 288 \times 4 = 1152$

$1152 + 300 = 1452$

$1452 \times 2 = 2904$

16)a)  $3 \times 3 = 9$

$2 \times 4 = 8$

$9 + 8 = 17$

$280.50 \div 17 = 16.50$

$16.50 \times 4 = \$66$

b) 1B  $\rightarrow 3 \times 16.50 = 49.50$

1D  $\rightarrow 4 \times 16.50 = 66$

9B  $\rightarrow 49.50 \times 9 = 445.50$

6D  $\rightarrow 66 \times 6 = 396$

$445.50 + 396 = \$841.50$

17)a) \$420

b) \$480

18)a)  $8k \rightarrow 14.85 + 5p$

$P = k + 1.35 \times 5$

$5p = 5k + 6.75$

$8k = (5k + 6.75) + 14.85$

$8k = 5k + 21.6$

$8k - 5k = 21.60$

$3k = 21.60$

$1k \rightarrow 21.60 \div 3 = 7.20$

$1p = 7.20 + 1.35 = \$8.55$

b)  $5p + 8k = (8.55 \times 5) + (7.2 \times 8) = \$100.35$