



Rosyth School
First Semestral Examination for 2015
SCIENCE
Primary 5

Name: _____

Class: Pr 5 - _____ Register No. _____ Duration: 1 h 45 min

Date: 14th May 2015 Parent's Signature: _____

Booklet A

Instructions to Pupils:

1. Do not open the booklets until you are told to do so.
2. Follow all instructions carefully.
3. This paper consists of 2 booklets, Booklet A and Booklet B.
4. For questions 1 to 30 in Booklet A, shade the correct ovals on the Optical Answer Sheet (OAS) provided using a 2B pencil.

* This booklet consists of 18 pages.

Part I

For each question from 1 to 30, four options are given. One of them is the correct answer. Make your choice (1, 2, 3 or 4). **Shade the correct oval (1, 2, 3 or 4) on the Optical Answer Sheet.** (60 marks)

1. Which one of the following organisms does not reproduce by spores?

(1)

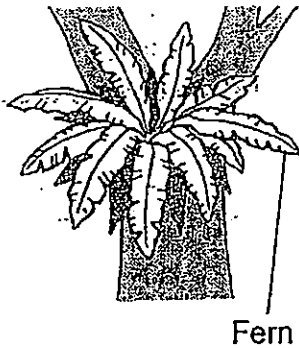

(2)

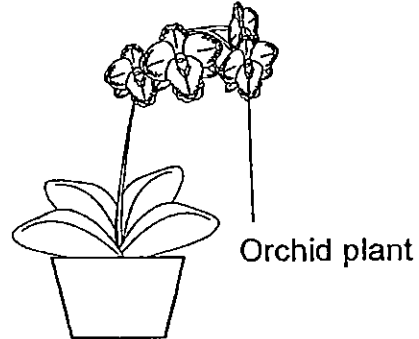

(3)

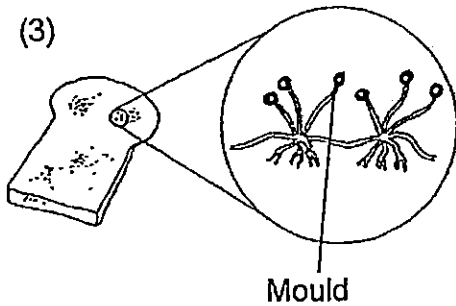

(4)

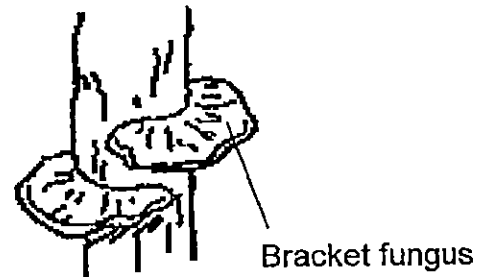

2. Which of the following statements about plants are correct?

A	They make food in their leaves.
B	They are made up of only cells that have chloroplasts.
C	They cannot move from place to place.
D	They absorb water through their roots

(1) A and C only

(2) B and D only

(3) A, C and D only

(4) A, B, C and D

3. Robbie made a few observations of an animal over some time. He recorded his observations as shown below.

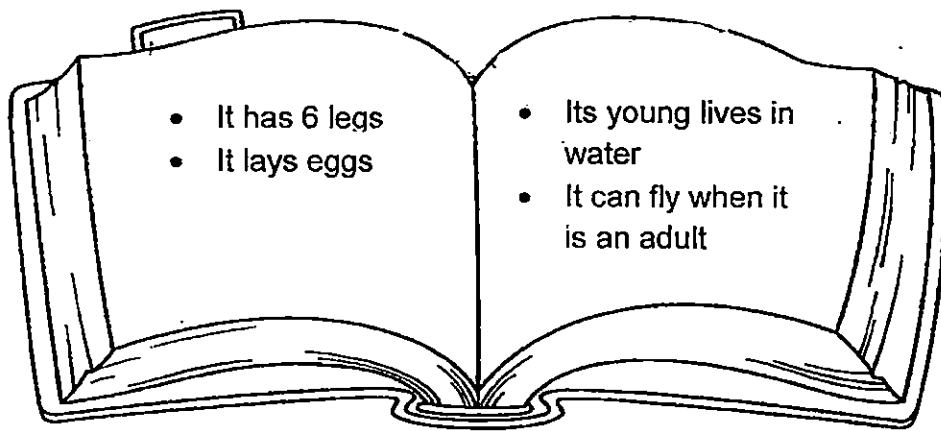

Which group does this animal belong to?

- | | |
|-------------|-------------|
| (1) Fish | (2) Birds |
| (3) Insects | (4) Mammals |
4. Jane used the set-ups below to find out if plants need carbon dioxide to make food in the presence of sunlight.

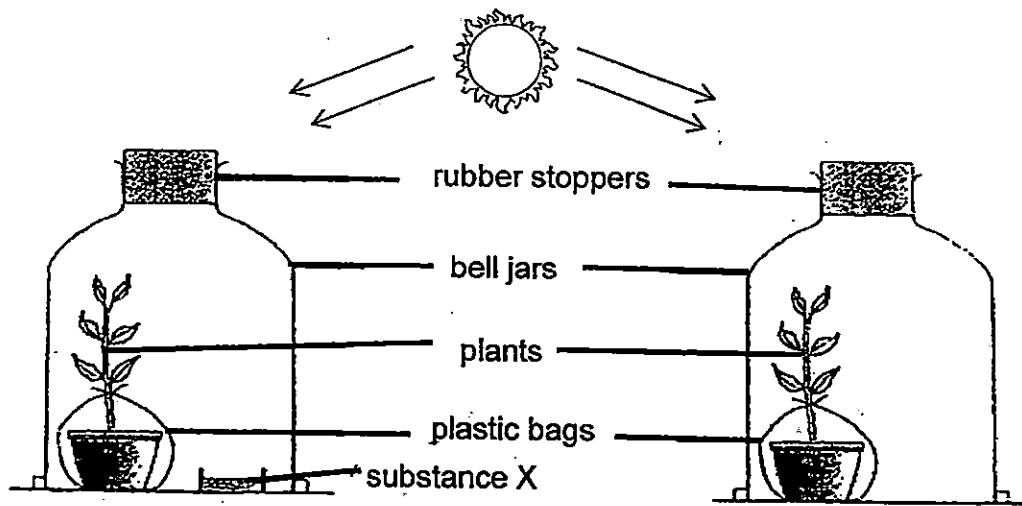

What was the purpose of placing substance X in one of the set-ups?

- 1) To remove all gases in the jar
- 2) To remove carbon dioxide in the jar
- 3) To increase the amount of gases in the jar
- 4) To increase the amount of carbon dioxide in the jar

5. Min Er conducted several tests on materials A, B, C and D and recorded her results in the table below.

Description	A	B	C	D
Is it strong?	Yes	No	No	Yes
Does it break easily?	No	Yes	Yes	No
Does it allow light to pass through?	No	Yes	No	Yes

Which material is the most suitable for making a bathroom door?

- (1) A (2) B
 (3) C (4) D
6. An experiment was conducted to test the strength of four different materials P, Q, R and S. Weights of same mass were hung on the different materials until they snapped.

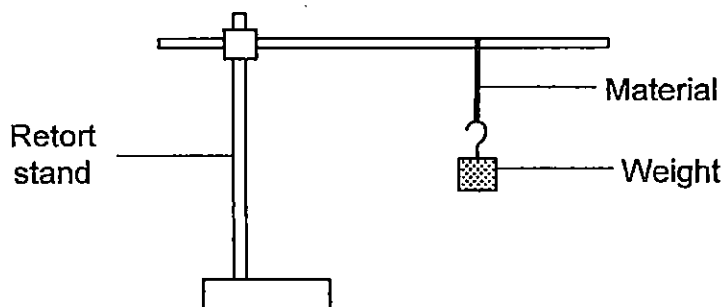

Results of the experiment were recorded in the table below.

Material	P	Q	R	S
Number of weights before material snapped	12	20	10	5

Which one of the following shows the correct order of increasing strength for materials P, Q, R and S?

	Weakest	→			Strongest
1)	S	R	P	Q	
2)	S	P	R	Q	
3)	Q	R	P	S	
4)	Q	P	R	S	

7. Why is it important for a unicellular organism to carry out cell division?

- A: To increase in size
- B: To replace old cells
- C: To repair damaged cells
- D: To ensure continuity of its own kind

Which of the above statement(s) is/are correct?

- 1) D only
- 2) B and C only
- 3) A, B and C only
- 4) A, B, C and D

8. Jack was given cells C, D, E and F from different parts of a plant and an animal. He observed the cells under the microscope and recorded his observations in the table below.

	Cell C	Cell D	Cell E	Cell F
Nucleus	x	✓	✓	✓
Cell wall	x	✓	x	✓
Cytoplasm	✓	✓	✓	✓
Chloroplast	x	x	x	✓
Cell membrane	✓	✓	✓	✓

Key
✓ : present
x : absent

Which of the cell(s) above is/are plant cell(s)?

- 1) F only
- 2) C and E only
- 3) D and F only
- 4) D, E and F only

9. Study the pictures below.

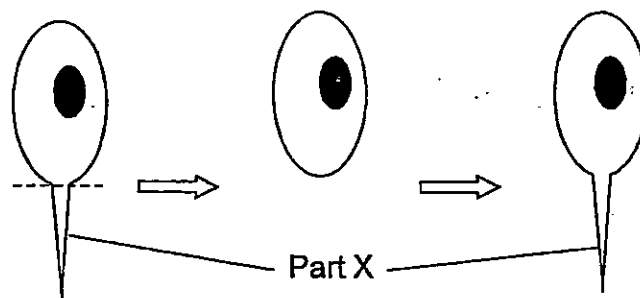

The animal cell shown above was used in an experiment. Part X was cut off. After some time, it was observed that part X that was cut off grew back.

Which of the following cell parts is needed for part X to grow back?

- 1) Nucleus
- 2) Cytoplasm
- 3) Cell wall
- 4) Cell membrane

10. Paul placed 40 bacteria cells into each of the two set-ups containing the same amount of water. Salt was added to one of the set-ups only. He then counted the number of bacteria cells in each set-up after 30 minutes.

What was the aim of his experiment?

- 1) To find out if the presence of salt would affect the reproduction of bacteria cells.
 - 2) To find out if the amount of salt would affect the size of bacteria cells.
 - 3) To find out if the presence of salt would affect the time taken for bacteria cells to reproduce.
 - 4) To find out if the amount of water would affect the number of bacteria cells reproduced.
11. Alvin set up an experiment to find out how different colours of light would affect the amount of water absorbed by plants.

The table below showed the information of the experimental set-ups.

Plants	P	Q	R	S
Amount of water absorbed by plant (ml)	40	20	20	40
Number of leaves on the plant	20	15	20	20
Amount of light that shines on plant (lux)	1000	800	1000	800
Colour of the light	Blue	Green	Green	Blue

Which pair of plants should Alvin compare for his experiment?

- | | |
|-------------|-------------|
| (1) P and Q | (2) P and R |
| (3) Q and S | (4) R and S |

12. Weihan classified three types of cells as shown below. Using the flowchart below, he was able to classify the three cells as cells X, Y and Z.

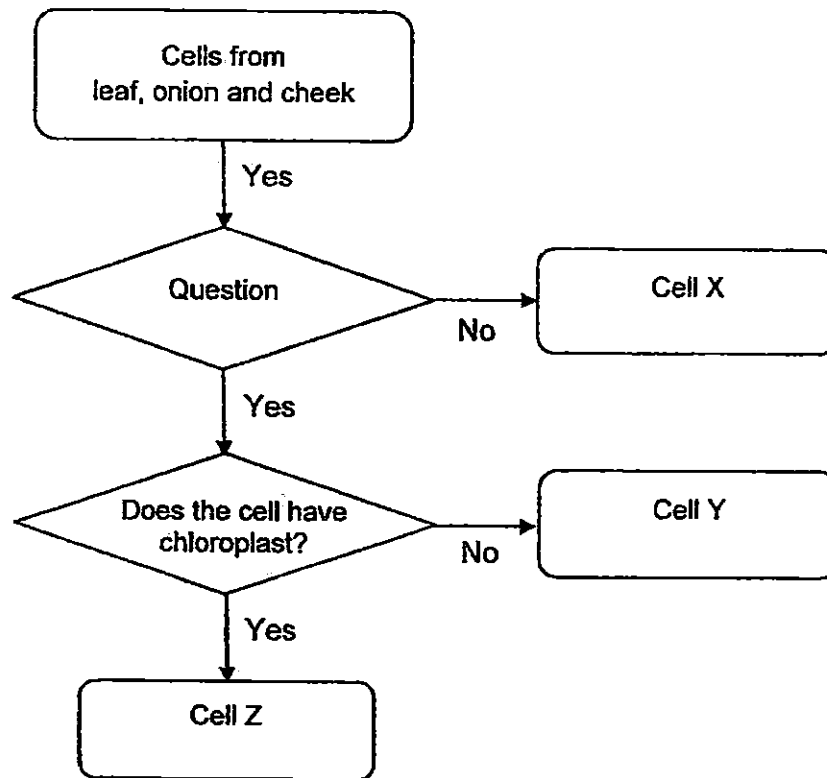

What is the question and Cell Y?

	Question	Cell Y
1)	Does the cell have a nucleus?	leaf
2)	Does the cell have cell membrane?	cheek
3)	Does the cell have a cytoplasm?	leaf
4)	Does the cell have a cell wall?	onion

13. Joyce placed the set-up below in a bright place.

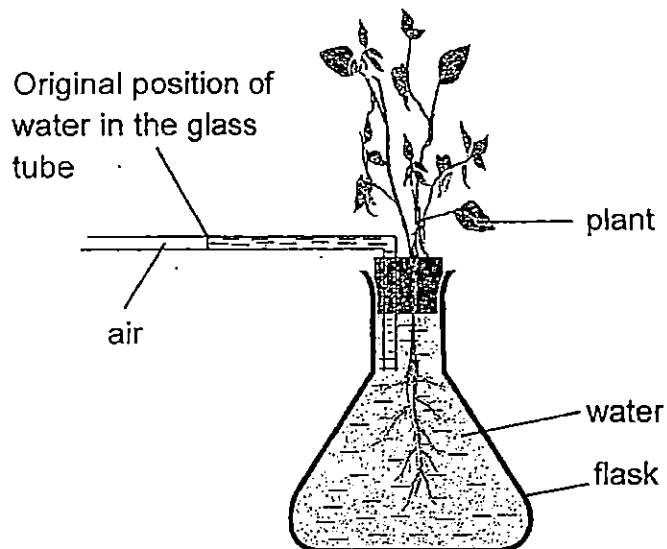

After some time, the water in the glass tube moved. Which direction did the water move and what was the reason for the movement?

	Direction in which the water in the glass tube moved	Reason
(1)	→	Carbon dioxide is given out by the plant
(2)	→	Water is taken in by the plant
(3)	←	Oxygen is given out by the plant
(4)	←	Water is given out by the plant

14. Four students carried out a class experiment by removing an outer ring of the stem between positions X and Y of a plant as shown below.

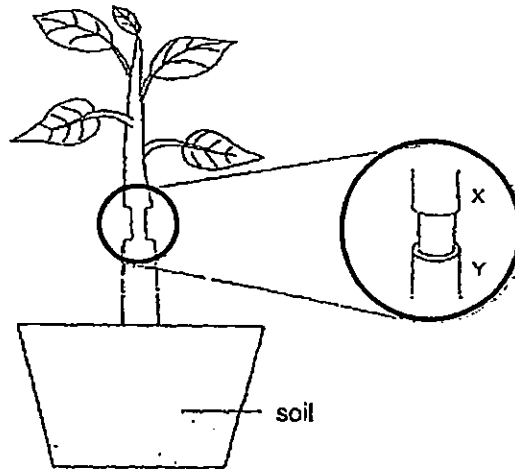

They left the plant under the sun and watered it regularly.

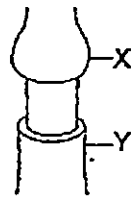

After a few days, they noticed the plant was alive and the part of the stem at X was swollen.

The four students, Paul, Quentin, Raine and Siti, explained the observation they had made.

- Paul : Food is being stored at position X.
Quentin : Only the water carrying tubes between positions X and Y are removed.
Raine : The water-carrying tubes are still present between positions X and Y.
Siti : Both water-carrying and food-carrying tubes are removed.

Which of these pupils' explanation were most likely correct?

- 1) Paul and Quentin
- 2) Raine and Siti only
- 3) Paul and Raine only
- 4) Quentin, Raine and Siti only

15. Wendy placed a plant with three white flowers X, Y and Z in a beaker containing blue-coloured water. After 40 minutes, flower Z turned blue while flowers X and Y remained white.

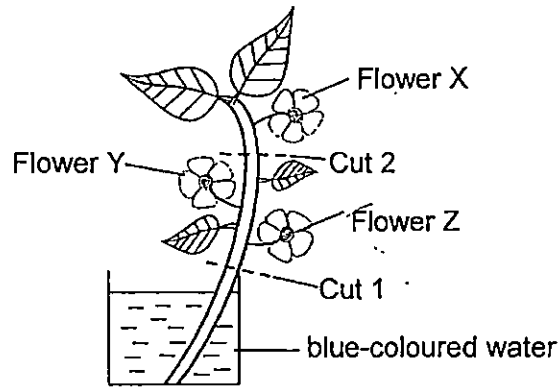

She made 2 cuts as shown in the diagram above.

This is the cross-sectional view of the stem she had cut.

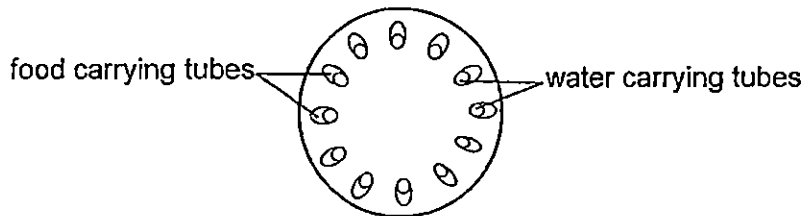

Which one of the following shows the cross sections of the stems at cuts 1 and 2 respectively?

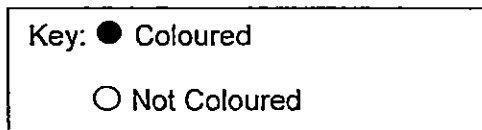

1)

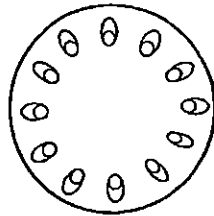

Cut 1

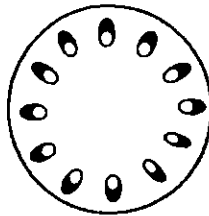

Cut 2

2)

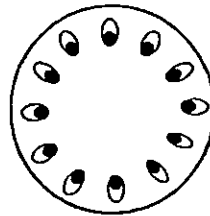

Cut 1

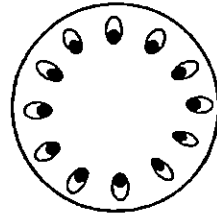

Cut 2

3)

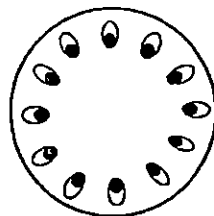

Cut 1

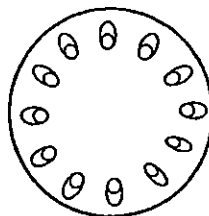

Cut 2

4)

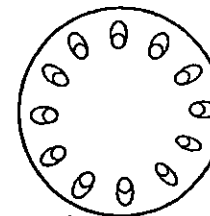

Cut 1

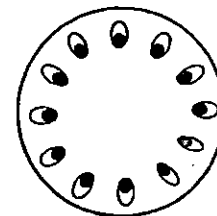

Cut 2

16. Dennis wanted to find out if plants take in water through their roots. He has prepared the set-up below.

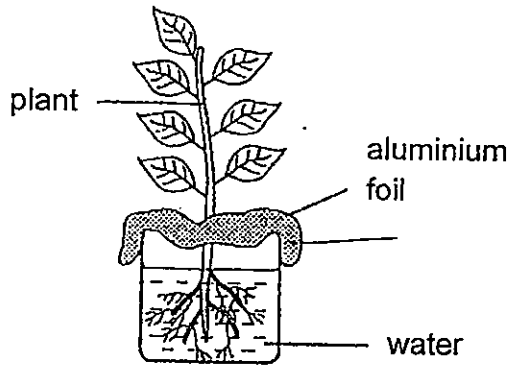

Which one of the following should Dennis use as a control for his experiment?

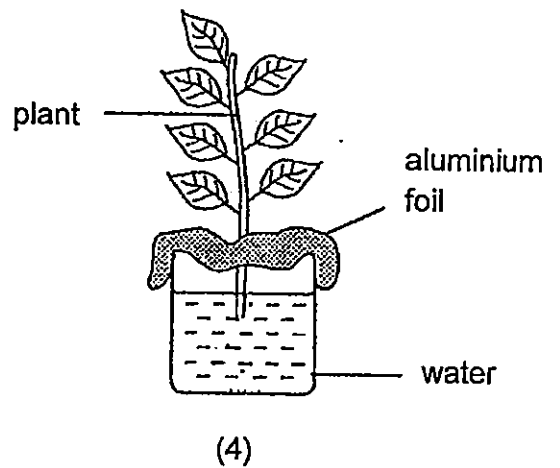
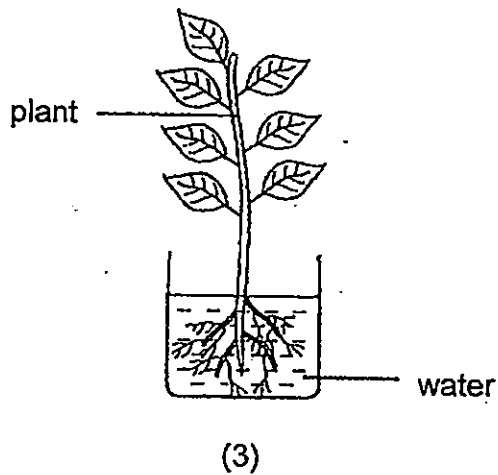
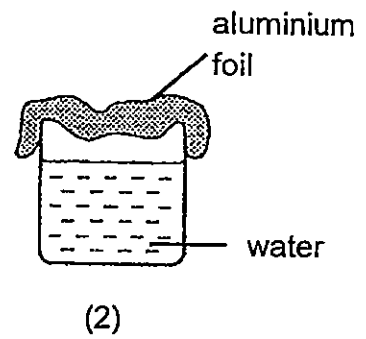
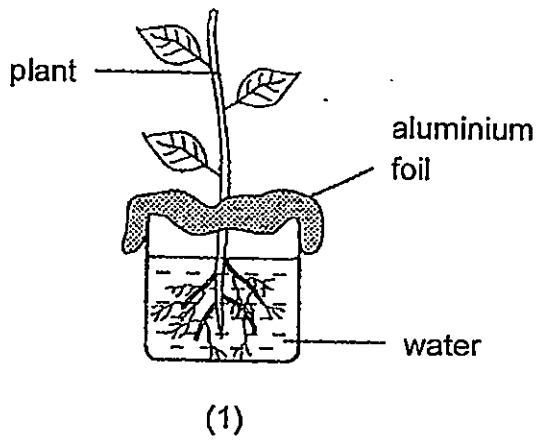

17. Which one of the following describes the function of each part in the digestive system correctly?

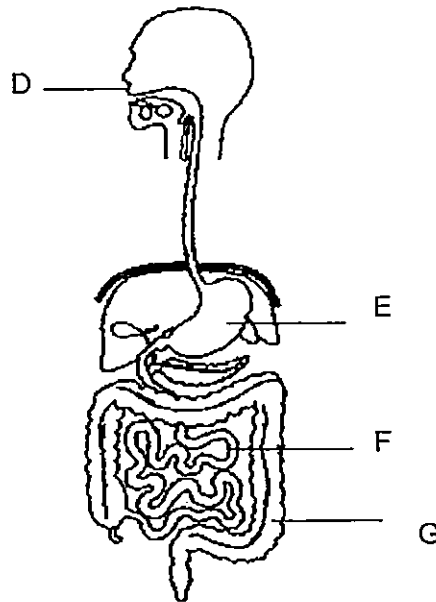

	Digestion takes place here	Most water is absorbed into the bloodstream	Food is absorbed into the bloodstream
1)	D, E, F	G	F
2)	E, F	D	F
3)	D, F, G	G	E
4)	F, G	E	D

18. Which of the following statements about our body systems are true?

A : The digestive system breaks down food into simple substances.

B : The circulatory system transports nutrients around our body.

C : The rib, gullet and lungs are part of the respiratory system.

D : The respiratory system transports oxygen from the lungs to all parts of the body.

- 1) A and B only
3) A, B and C only

- 2) C and D only
4) A, B and D only

19. A boy was running for his 1.6km test . Which of the following body systems interacted together to enable him to run?

- A: Skeletal System ✓
- B: Muscular System ✓
- C: Digestive System ✓
- D: Circulatory System ✓
- E: Respiratory System ✓

- (1) A and B only
- (2) C, D and E only
- (3) B, C, D and E only
- (4) A, B, C, D and E

20. Which of the following substances are transported by the blood?

- A : water ✓
- B : oxygen ✓
- C : digested food ✓
- D : carbon dioxide ✓
- E : waste materials ✓

- (1) B and C only
- (2) B, C and D only
- (3) A, B, C and D only
- (4) A, B, C, D and E

21. Susan went for a run. The table below shows the activity that took place in a period of time.

Time (minutes)	Activity
0 - 10	Running
11 - 20	Running
21 - 30	Running
31 - 40	Coming to a stop
41 - 50	Resting

Which one of the following best represents what is happening in her body between the 11th to 30th minute?

	Rate of carbon dioxide released	Rate of blood flow	Rate of energy released from digested food
(1)	Increase	Decrease	Increase
(2)	Decrease	Increase	Decrease
(3)	Increase	Increase	Increase
(4)	Decrease	Decrease	Decrease

22. The following graph shows the effect of the same intensity of exercise on the heart rate of a trained athlete and an untrained one. They stopped exercising after 30 minutes. A graph showing their rate of heartbeat is plotted below.

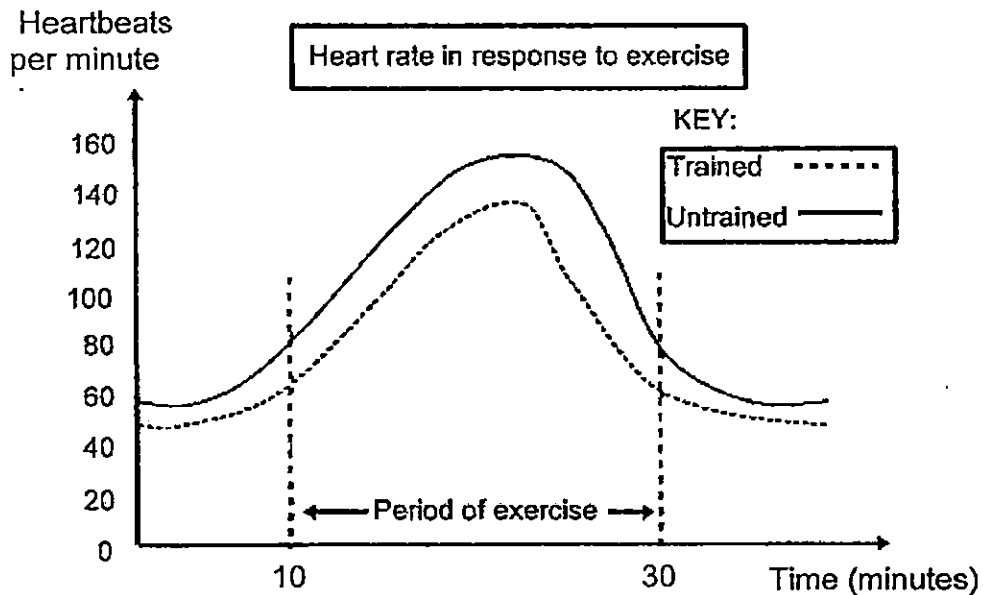

Based on the graph above, which one of the following statements is true?

- 1) Both athletes are using the same amount of oxygen.
- 2) The trained athlete is using more oxygen to complete the exercise.
- 3) The resting heart rate of an untrained athlete is lower than that of a trained athlete.
- 4) The resting heart rate of a trained athlete is lower than that of an untrained athlete.

23. Benny did a cross-section of the Leaf P and observed it under a microscope. He observed structure Q as shown below.

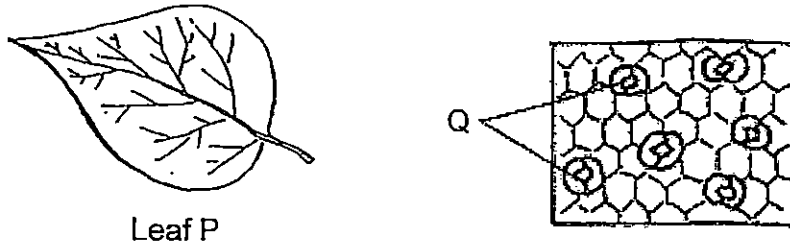

Which of the following statements are true about structure Q?

- A: They allow the exchange of gases to take place. T
- B: They trap sunlight needed to make food for the plant. F
- C: They are usually found on the underside of leaves away from sunlight. T
- D: They can take in water found on the leaf to be transported to all parts of the plant. F

- 1) A and B only
- 2) A and C only
- 3) A, B and C only
- 4) A, B, C and D

24. Martin was making comparisons between how a man and a fish breathe.

	Man	Fish
A	Air containing oxygen enters through the nose and gets into the lungs.	Water containing dissolved oxygen enters through the mouth and passes over the gills.
B	Oxygen from the air gets into the lungs.	Oxygen from the air gets into the gills.
C	Carbon dioxide passes into the lungs and is removed when breathe out.	Carbon dioxide is carried away as water flows out from under the gill covers.

Which of the above comparisons are true?

- 1) A and B only
- 2) A and C only
- 3) B and C only
- 4) A, B and C

25. All the batteries, wires and bulbs used in each of the four electrical circuits below are new and identical.

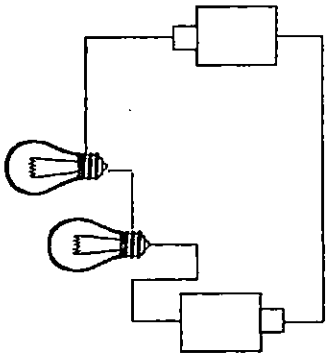

Circuit A

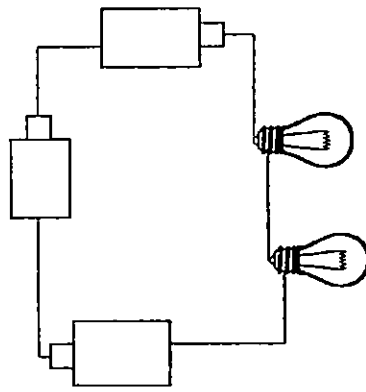

Circuit B

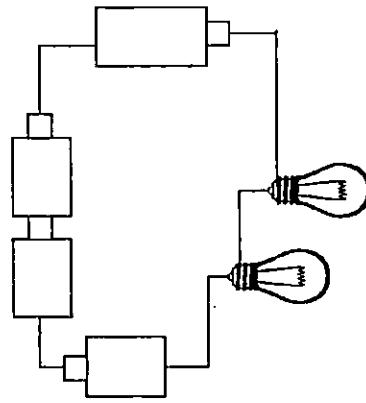

Circuit C

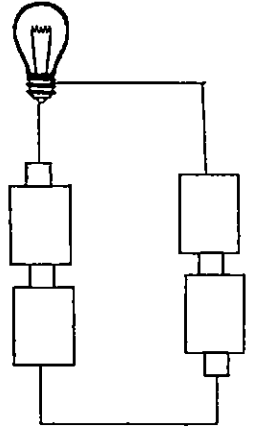

Circuit D

Arrange the circuits from the brightest to the least bright.

- (1) C, B, A, D
(2) D, A, B, C
(3) C, D, B, A
(4) D, C, B, A
26. Lily wanted to find out how the arrangement of bulbs in a circuit affects the brightness of the bulbs. Which variables should she keep the same for a fair experiment?

A: The length of wire
B: The number of bulbs
C: Brightness of the bulbs
D: The number of batteries

- (1) A and B only
(2) B and D only
(3) A, C and D only
(4) A, B and D only

27. Study the electric circuit below.

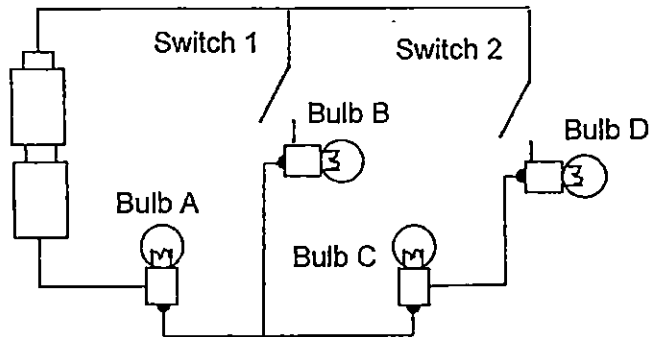

Which one of the following correctly shows the bulbs that will light up when the switches are closed one at a time?

	Only when Switch 1 is closed	Only when Switch 2 is closed
(1)	Bulbs A and B	Bulbs C and D
(2)	Bulbs A and B	Bulbs A, C and D
(3)	Bulbs A and C	Bulbs A, C and D
(4)	Bulbs B, C and D	Bulbs B, C and D

28. The diagram below shows a closed electric circuit connecting four identical Bulbs P, Q, R and S. All the bulbs light up.

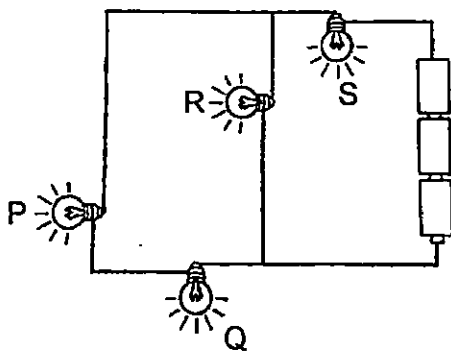

Which of the following statement(s) about the circuit is/are true?

- A: Bulbs R and S are connected in series.
- B: Bulbs P and R have the same brightness.
- C: If Bulb P fuses, Bulbs R and S will still light up.

- 1) A only
- 2) A and C only
- 3) B and C only
- 4) A, B and C

29. Victor wanted to find out how the number of batteries will affect the brightness of the bulb(s) in a circuit.

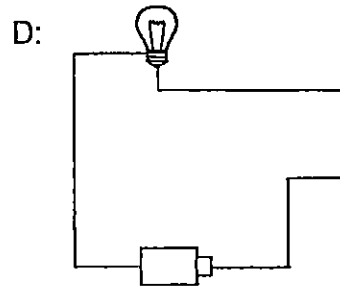
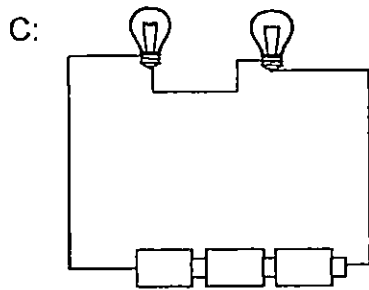
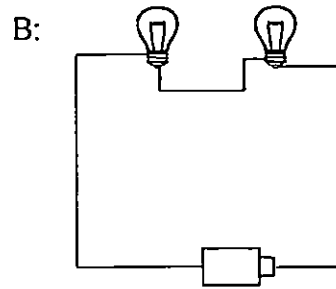
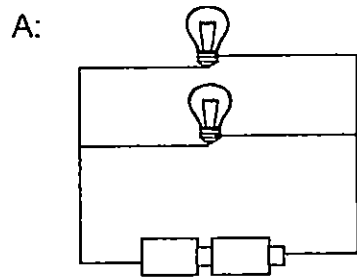

Which set-ups should he use for a fair experiment?

- 1) A and D only
- 3) B and C only

- 2) A, B and C only
- 4) A, B, C and D

30. The diagram below shows 4 bulbs C, D, E and F in a circuit that are connected correctly.

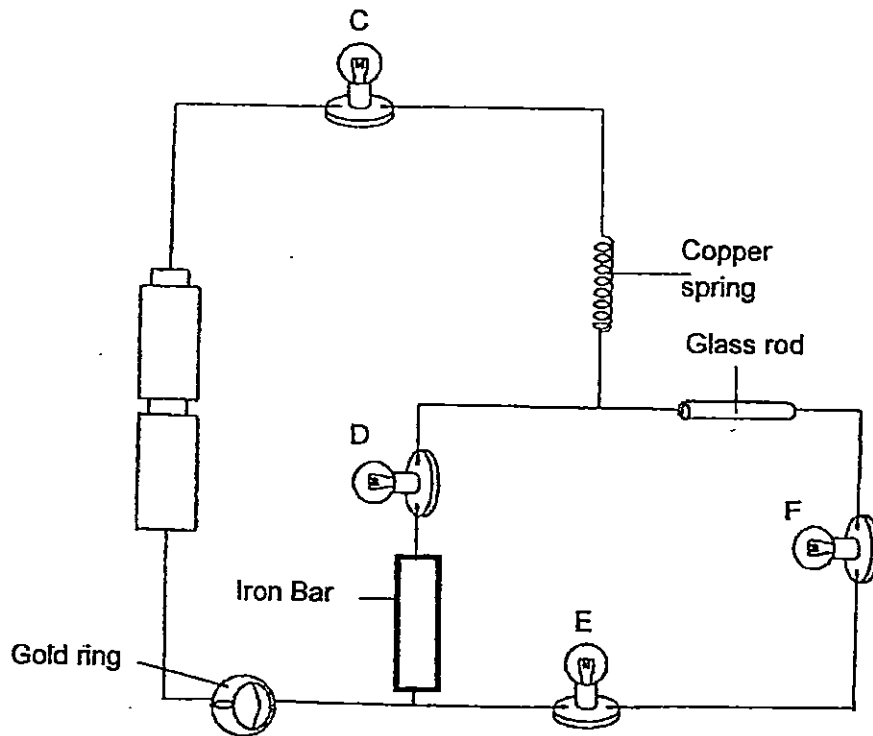

Which of these bulbs will not light up?

- | | |
|--------------------|------------------|
| 1) C and D only | 2) E and F only |
| 3) C, E and F only | 4) C, D, E and F |



Rosyth School
First Semestral Examination for 2015
SCIENCE
Primary 5

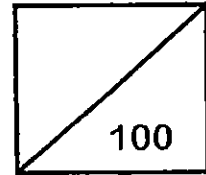

Name: _____

Total
Marks:

Class: Pr 5 - _____ Register No. _____ Duration: 1 h 45 min

Date: 14th May 2015 Parent's Signature: _____

Booklet B

Instructions to Pupils:

1. For questions 31 to 44, write your answers in the spaces given in this booklet.

	Maximum	Marks Obtained
Booklet A	60 marks	
Booklet B	40 marks	
Total	100 marks	

* This booklet consists of 14 pages.

PART II

For questions 31 to 44, write your answers in this booklet.

(40 marks)

31. Nathan conducted an experiment using five different materials A, B, C, D and E, a torch and a light sensor. He conducted the experiment in a dark room and set up the experiment as shown below.

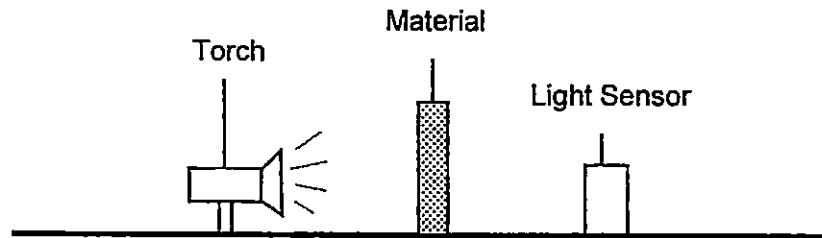

He recorded his findings in the graph below.

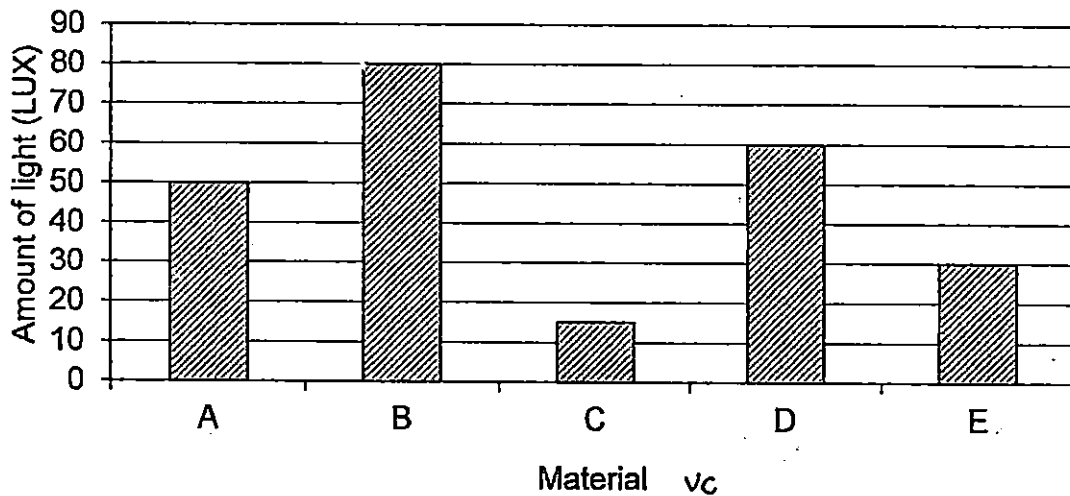

- (a) What was the aim of his experiment? (1m)

- (b) Out of the five materials A, B, C, D and E, which material would be the most suitable to make the windscreen of a car? Explain your answer. (1m)

32. Tim wanted to find out how the amount of water present would affect the growth of mould on bread. He set up an experiment with three similar pieces of bread A, B and C. He sprinkled different amount of water onto the pieces of bread and packed them into the sealed bag.

He measured the area of mould that grew on the different pieces of bread every two days and recorded the results in the table below.

Bread	Amount of water sprinkled on bread (ml)	Area of mould observed (cm ²)			
		Day 0	Day 2	Day 4	Day 6
A	5	0	0	2	3
B	10	0	3	5	8
C	20	0	5	7	12

(a) Based on the above results, state the relationship between the amount of water sprinkled on the bread and the growth of mould on bread. (1m)

(b) Put a tick (✓) on the variable(s) that Tim would need to keep constant to ensure his experiment is a fair test. (1m)

	size of sealed bag
	amount of water sprinkled on bread
	temperature of surrounding

(c) Tim repeated his experiment under a lighted lamp. He noticed that there was more mould growing on all the pieces of bread. How has the presence of the lighted lamp increase the growth of mould? (1m)

33. Daphne took a cell from a plant for an experiment. She immersed the cell in a dish containing same amount of substances X, Y and Z.

The diagram below showed what happened an hour after the cell was placed in the dish containing the three substances.

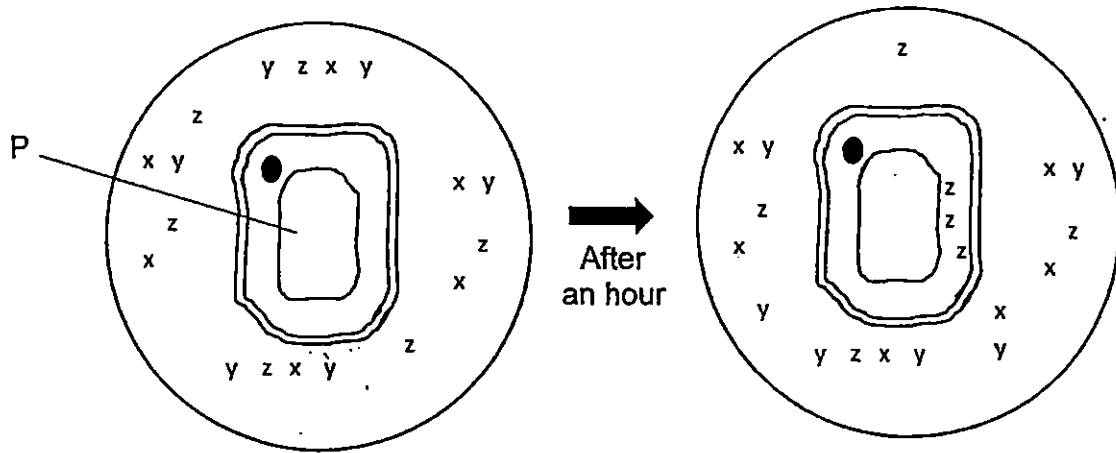

- (a) What observations did Daphne make with regard to the 3 substances X, Y and Z after an hour? (1m)

- (b) Which part of the cell was responsible for the observations made in (a)? (1m)

- (c) It is observed that part P of the cell becomes bigger when the plant takes in water. Will the cell burst if the plant takes in more water? Explain your answer. (1m)

34. Study the three different cells A, B and C as shown below.

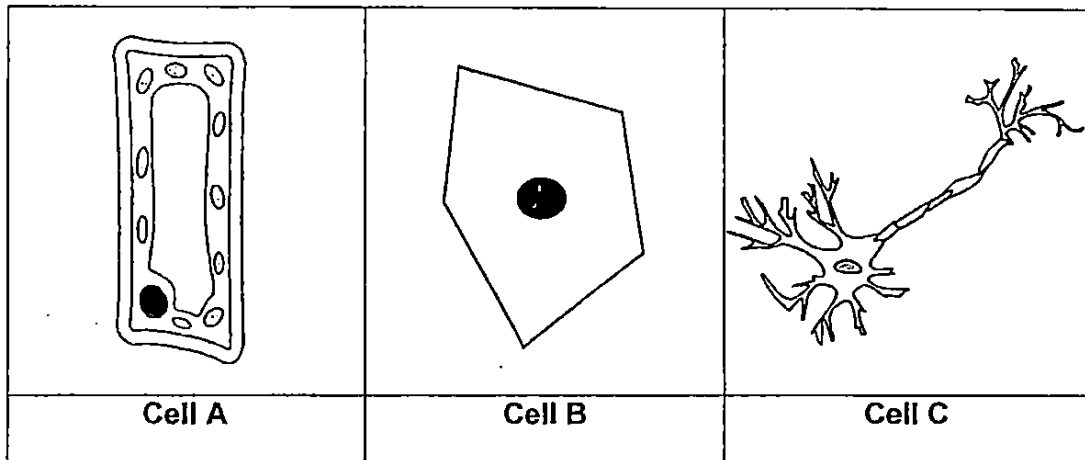

(a) Name a part of the cell that can be found in Cell A but not in Cell B and C. (1m)

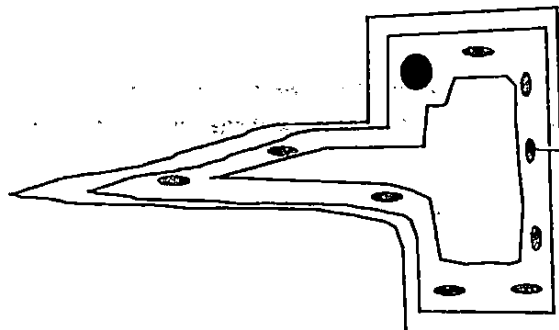

(b) Why do these cells have different shapes? (1m)

Study the root cell drawn by Kendrick as shown below.



(c) In the drawing above, draw a line and label the part of the cell that should not be present. Explain why this part should not be found in a root cell. (2m)

35. Mr Lim wanted to find out how the amount of sugar dissolved in water would affect the freshness of the flower. He carried out an experiment by placing a flower stalk into each of the containers A, B and C with different amount of sugar solutions. After some time, he then measured the number of days that the flowers remained fresh.

Container	Number of teaspoons of sugar dissolved in water	Amount of water (ml)
A	1	250
B	2	250
C	3	250
control set-up	(a) 	(a) 

- (a) Mr Lim needed to have a control set-up. Complete the information in the table above. (1m)

- (b) What is the purpose of the control set-up? (1m)

- (c) Besides the flower stalk, name 2 other variables that need to remain unchanged for this experiment. (2m)

Variable 1: _____

Variable 2: _____

36. Xiao Ping conducted an experiment in a classroom using set-ups A and B as shown. She removed most of the leaves from set-up B. She then recorded the water level, H, at regular time intervals.

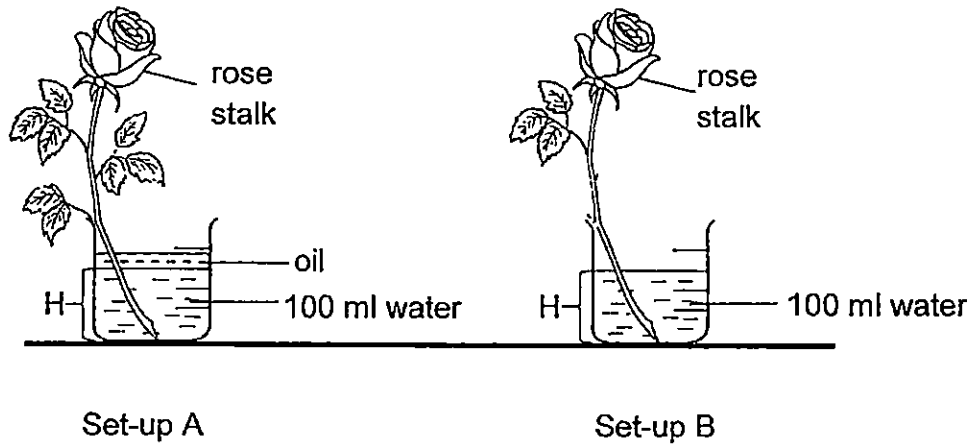

- (a) Explain why her experiment is not a fair one. (1m)

After ensuring that her experiment is fair, she obtained the results as shown in the graph below:

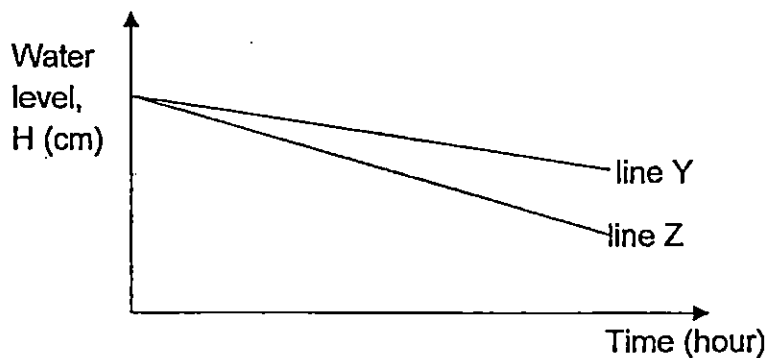

- (b) Which line, Y or Z, represents the results obtained for the flower stalk with more leaves. Explain your answer. (1m)

37. The diagram below shows part of the human respiratory system.

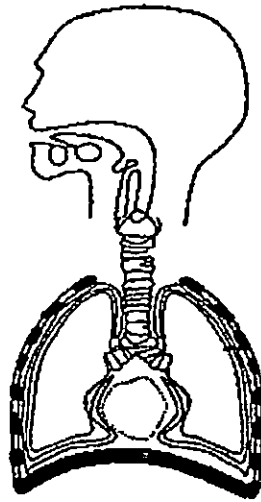

(a) In the diagram, draw a line and name the part that allows air to flow from the nose to the lungs. (1m)

(b) The diagram below shows a filter paper placed in a funnel. It is used to filter the sand from the water.

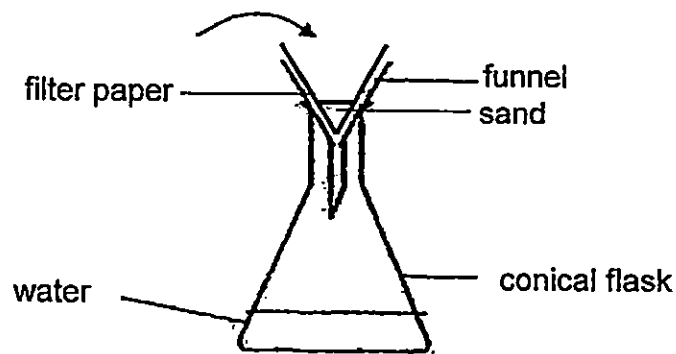

How is the function of the filter paper similar to that of the fine hairs in the nose? (2m)

38. Ali conducted an experiment to find out how the amount of light affects the size of stomata found on a leaf. He recorded his observation and sketched two graphs as shown below to provide information about the size of stomata found on a leaf.

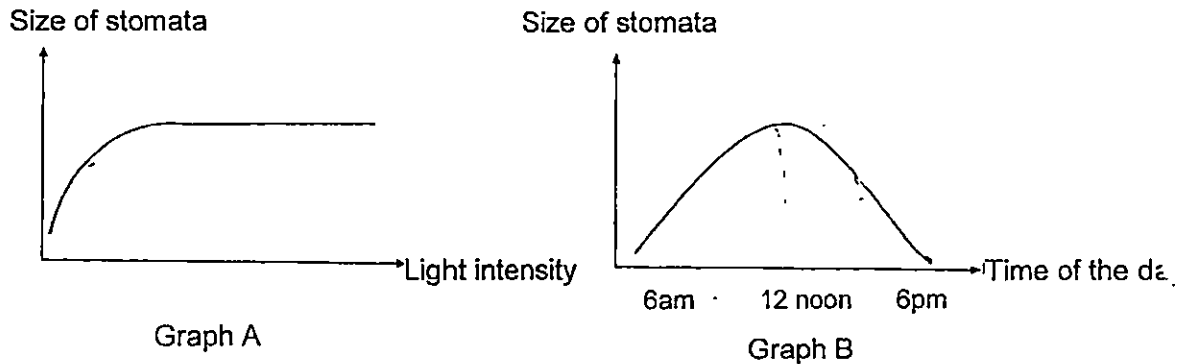

Graph A shows how light intensity affects the size of stomata while graph B shows how the size of stomata changes with the time of the day.

- (a) Ali concluded that as light intensity increases, the size of stomata increases. Is his conclusion accurate? (1m)

- (b) Based on the graphs A and B above, explain why the size of stomata is the greatest at 12 noon? (1m)

39. Study the diagram below.

Plant Transport System

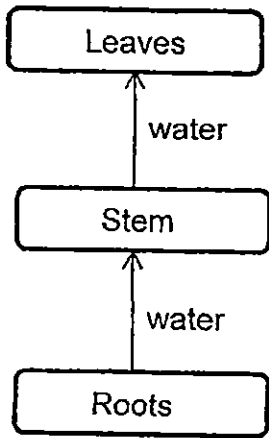

Human Transport System

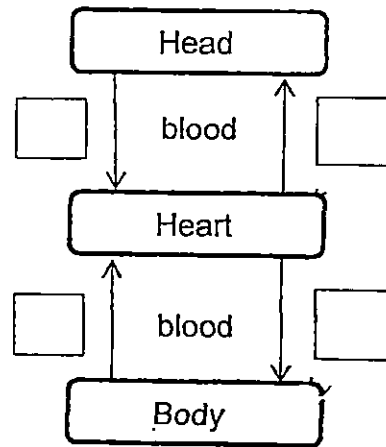

- (a) In the human transport system above, tick the box(es) which represent(s) blood rich in oxygen. (1m)
- (b) Based on the diagram above, how is the directional flow of water in the plant transport system different from the directional flow of blood in the human transport system? (1m)

40. The diagram below shows the different systems in the human body working together.

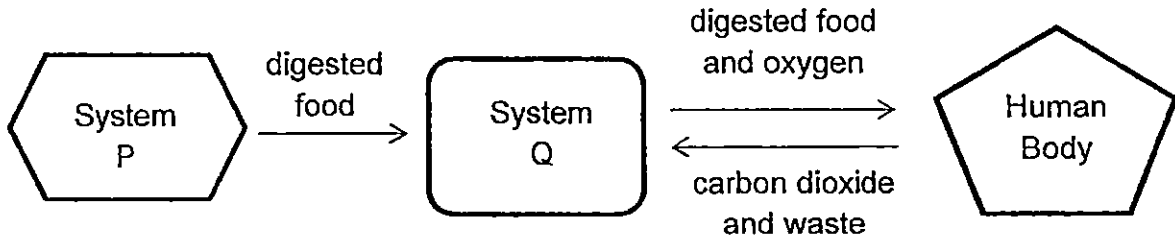

(a) Name Systems P and Q as shown in the diagram above. (1m)

i) System P: _____

ii) System Q: _____

(b) Describe how these two systems work together in the human body. (2m)

41. Casper and Don recorded their heart rate immediately after carrying out 10 minutes of jogging. After two minutes of resting, they measured their heart rate and recorded them. ~~He~~ ^{They} also measured ~~his~~ ^{their} heart ~~rate~~ ^{rates} after fifteen minutes of rest

	Heart rate			
	2 minutes before jogging	Just after jogging	2 minutes after activity	15 minutes after jogging
Casper	72	120	105	71
Don	72	140	110	72

(a) Explain why their heart rate was higher when they were jogging. (2m)

(b) State what happened to their heart rate 15 minutes after jogging. (1m)

(c) Give a possible reason why Don's heart rate is higher than Casper's heart rate just after jogging. (1m)

42. The diagram below shows a game which requires one to move a metal loop through a length of curved wire. The game tests the steadiness of the player's hand. If the player's hand is not steady and the loop touches the curved wire, the bulb will light up.

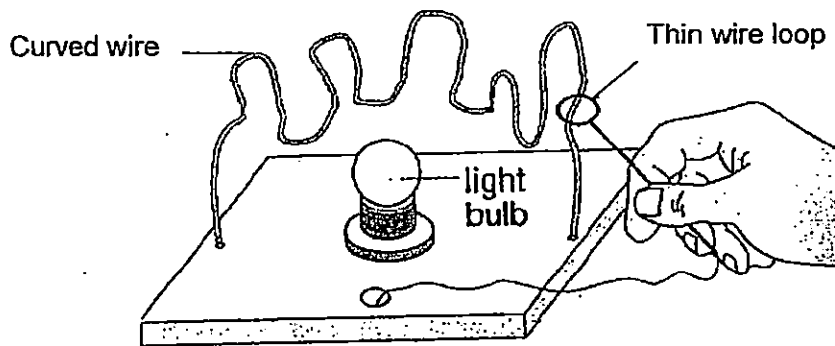

- (a) What property should the thin wire loop have in order for it to be used in this game? (1m)

- (b) Why does the bulb light up when the loop touches the curved wire? (1m)

43. Colin used four new and identical bulbs and four identical batteries to set up two electric circuits as shown below.

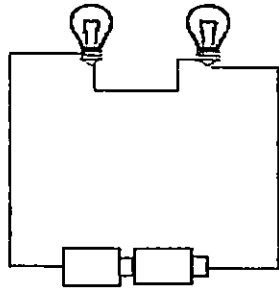

Circuit P

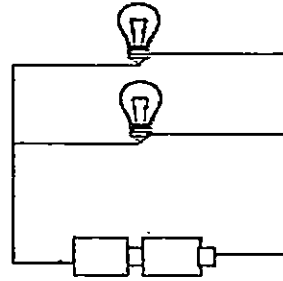

Circuit Q

- (a) Which electric circuit P or Q, do the bulbs light up more brightly? (1m)

- (b) Besides changing the arrangement and number of bulbs, what can be done to the other circuit to cause the bulbs to light up brighter? (1m)

- (c) Electric appliances in our homes are usually arranged similar to circuit Q. State a reason why. (1m)

44. An iron bar becomes a magnet when it is placed in a coil of wire connected to the battery. A steel nail was suspended freely between two iron bars A and B as shown below.

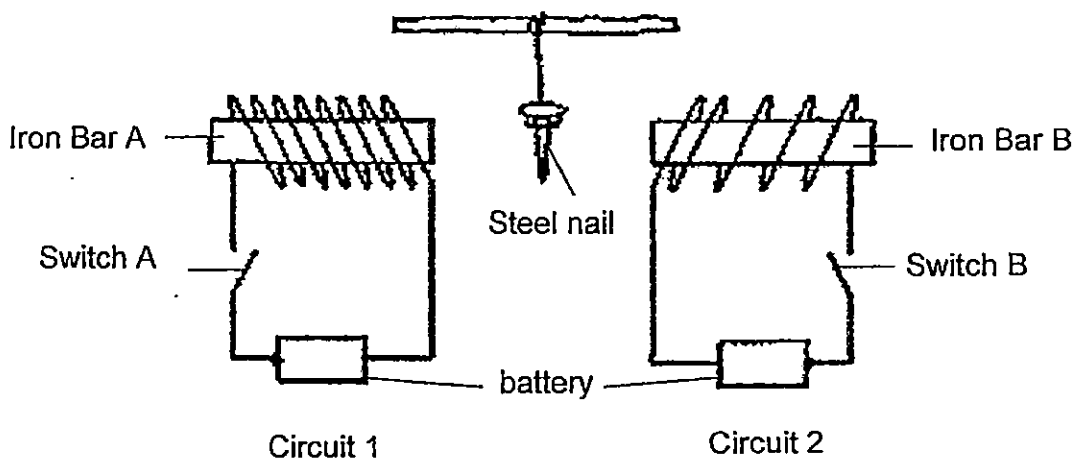

- (a) Which variable was changed in the above experiment? (1m)

- (b) What will happen to the steel nail if only Switch B is closed? (1m)

- (c) What will happen to the steel nail if both Switch A and B are closed at the same time? (1m)

--- END OF PAPER ---



EXAM PAPER 2015

LEVEL : PRIMARY 5

SCHOOL : ROSYTH SCHOOL

SUBJECT : SCIENCE

TERM : SA1

BOOKLET A

Q 1	Q 2	Q 3	Q 4	Q 5	Q 6	Q 7	Q 8	Q 9	Q 10
2	3	3	2	1	1	1	3	1	1
Q 11	Q 12	Q 13	Q 14	Q 15	Q 16	Q 17	Q 18	Q 19	Q 20
2	4	2	3	3	4	1	1	4	4
Q 21	Q 22	Q 23	Q 24	Q 25	Q 26	Q 27	Q 28	Q 29	Q 30
3	4	2	2	4	4	1	2	3	1

BOOKLET B – REFER TO ATTACHED ANSWER KEY

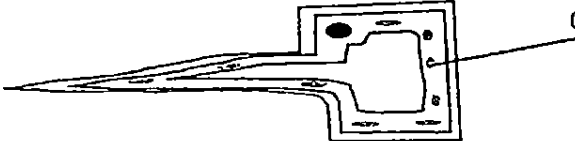
31a	To find out if /how different materials affects the amount of light that passes through the material / To find out if/ how the <u>degree of transparency</u> of the materials would affect the amount of light that passes through the material. To find out which material allow the most light to pass through.
b	B. It allows the most amount of light to pass through. B allowed more light to pass through than the rest of the materials.
32a	As the amount of water sprinkled on bread increases, the growth of mould on bread increases/ The more the amount of water sprinkled on bread, the greater the growth of mould on bread. As the amount of water sprinkled on bread increases, the rate of growth of mould on bread increases/ the faster the growth of mould. As the amount of water sprinkled on bread increases, the <i>area of mould on bread increases (1/2)</i>
b	• Size of sealed bag • Temperature of surrounding
c	Lighted lamp → provides heat/warmth → promotes growth of mould (need warmth, moisture and air/oxygen) It causes an increase in temperature of the air in the plastic bag/ air in the plastic bag became warmer/ temperature of surrounding became warmer for the mould to grow faster.
33 a	Some substance Z have entered the cell and no substance X and Y have entered the cell .
b	Cell membrane
c	No. Cell has cell wall that supports and provides strength to the cell.
34a	Any one of the answers: Cell wall chloroplast central vacuole
b	Cells have different shapes to carry out different functions.
c	 Chloroplasts (must draw correct line and label) Root cell does not have chloroplast as it does not make food
35a	

control setup	(a) <input type="text" value="0"/>	(a) <input type="text" value="250"/>
---------------	------------------------------------	--------------------------------------

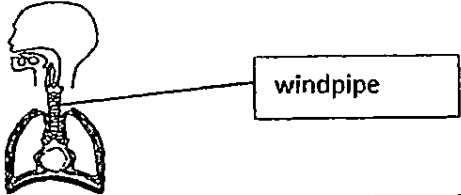
b	To prove/confirm/ensure that sugar / or the amount of sugar is the only variable that affects the freshness of the flowers. / the number of days that flowers remained fresh
c	<ul style="list-style-type: none"> • Temperature of the water • Amount of light/sunlight • Type /size of sugar • Amount of water • Temperature of surrounding air
36a	She did not put a layer of oil on top of the water in setup B
b	Line Z. As the flower stalk has more leaves, the amount of water taken in by the stalk is more.
37a	 windpipe
b	The filter paper filters/separates the sand from the water just like the hair in the nose that traps the dust and dirt from the air we breathe in / entering the body.
38a	No. As light intensity increases, the size of stomata increases and then remains the same/constant when maximum size is reached.
b	At 12 noon, the light intensity is the highest /brightest OR At 12 noon, the amount of light is the most.
39a	Tick the boxes from the heart to the head and from the heart to the body.

b	Water is transported from the roots upwards towards the leaves in a single direction/unidirectionally but blood is transported / circulated from the heart to all parts of the body and then back to the heart again OR from the heart to the head and body and back to the heart again.
40a	P: Digestive System Q: Circulatory System
b	Food is digested by the digestive system and the digested food enters the blood/bloodstream/is absorbed into the blood. (1m) The digested food in the blood is then transported to all parts of the body by the circulatory system. The digestive system digests the food into simpler substances which is absorbed into the blood stream so that the circulatory system can transport the digested food to all parts of the body .
41a	The heart has to pump harder/faster to supply more oxygen (and digested food) to the body (and to remove carbon dioxide faster). When they were jogging, their bodies need more energy. So the heart pumped faster in order to provide the body with more oxygen and digested food to release more energy.
b	The heart rate returns to the resting heart rate/ back to normal heart rate. The heart rate decreases/slowed down to about the heart rate at 2 minutes before he started jogging .
c	Don may have jogged faster/jogged more vigorously/ Don's jogging intensity is higher →intensity Don may be younger so his heart rate is higher Casper may be more athletic/ is fitter Casper may exercise frequently/exercise regularly→frequency
42a	It is a conductor of electricity/ an electrical conductor
b	When the loop touches the curved wire, it forms a complete circuit. So, the current flows / passes though the circuit / bulb causing the bulb to light up.
43a	The bulbs in circuit Q will light up more brightly
b	Add more batteries or increase the voltage of the batteries
c	Bulbs/appliances arranged in Q allows/enables the other bulbs/ appliances to remain working if one bulb fuses /appliance is faulty (as there are more than 1 pathway/separate pathways for electricity to flow) OR It allows the other appliances to remain working if one appliance is turned off.
44a	The number of coils around the iron rod.
b	The steel nail will be attracted to iron rod B. The steel nail will move towards to iron rod B (1/2)
c	The steel nail will be attracted to iron rod A. The steel nail will move towards to iron rod A (1/2)

THE END