

**TEMASEK JUNIOR COLLEGE**

**2022 JC2 PRELIMINARY EXAMINATION**

**Higher 2**



CANDIDATE  
NAME

CENTRE  
NUMBER

S				
---	--	--	--	--

INDEX  
NUMBER

--	--	--	--

**PHYSICS**

**9749/01**

Paper 1 Multiple Choice

**15 September 2022**

**1 hour**

Additional Materials: Multiple Choice Answer Sheet

**READ THESE INSTRUCTIONS FIRST**

Write in soft pencil.

Do not use staples, paper clips, glue or correction fluid.

Write your name and Civics group on the Answer Sheet in the spaces provided.

There are **thirty** questions in this paper. Answer **all** questions. For each question there are four possible answers, **A, B, C** and **D**.

Choose the **one** you consider correct and record your choice in **soft pencil** on the separate Answer Sheet.

Each correct answer will score one mark. A mark will not be deducted for a wrong answer.

Any rough working should be done in this booklet.

The use of an approved scientific calculator is expected, where appropriate.

**Do NOT open the booklets until you are told to do so.**

This booklet consists of **14** printed pages.

**Data**

speed of light in free space

permeability of free space

permittivity of free space

elementary charge

the Planck constant

unified atomic mass constant

rest mass of electron

rest mass of proton

molar gas constant

the Avogadro constant

the Boltzmann constant

gravitational constant

acceleration of free fall

$$c = 3.00 \times 10^8 \text{ m s}^{-1}$$

$$\mu_0 = 4 \pi \times 10^{-7} \text{ H m}^{-1}$$

$$\epsilon_0 = 8.85 \times 10^{-12} \text{ F m}^{-1}$$

$$= (1/(36\pi)) \times 10^{-9} \text{ F m}^{-1}$$

$$e = 1.60 \times 10^{-19} \text{ C}$$

$$h = 6.63 \times 10^{-34} \text{ J s}$$

$$u = 1.66 \times 10^{-27} \text{ kg}$$

$$m_e = 9.11 \times 10^{-31} \text{ kg}$$

$$m_p = 1.67 \times 10^{-27} \text{ kg}$$

$$R = 8.31 \text{ J K}^{-1} \text{ mol}^{-1}$$

$$N_A = 6.02 \times 10^{23} \text{ mol}^{-1}$$

$$k = 1.38 \times 10^{-23} \text{ J K}^{-1}$$

$$G = 6.67 \times 10^{-11} \text{ N m}^2 \text{ kg}^{-2}$$

$$g = 9.81 \text{ m s}^{-2}$$

**Formulae**

uniformly accelerated motion

$$s = ut + \frac{1}{2}at^2$$

$$v^2 = u^2 + 2as$$

$$W = p\Delta V$$

work done on / by a gas

$$p = \rho gh$$

hydrostatic pressure

$$\phi = -Gm/r$$

gravitational potential

$$T/K = T/^\circ\text{C} + 273.15$$

temperature

$$p = \frac{1}{3} \frac{Nm}{V} \langle c^2 \rangle$$

pressure of an ideal gas

$$E = \frac{3}{2}kT$$

mean translational kinetic energy of an ideal gas molecule

$$x = x_0 \sin \omega t$$

displacement of particle in s.h.m.

$$v = v_0 \cos \omega t = \pm \omega \sqrt{x_0^2 - x^2}$$

velocity of particle in s.h.m.

$$I = Anvq$$

electric current

$$R = R_1 + R_2 + \dots$$

resistors in series

$$1/R = 1/R_1 + 1/R_2 + \dots$$

resistors in parallel

$$V = Q/(4\pi\epsilon_0 r)$$

electric potential

$$x = x_0 \sin \omega t$$

alternating current / voltage

$$B = \frac{\mu_0 I}{2\pi d}$$

magnetic flux density due to a long straight wire

$$B = \frac{\mu_0 NI}{2r}$$

magnetic flux density due to a flat circular coil

$$B = \mu_0 nI$$

magnetic flux density due to a long solenoid

$$x = x_0 \exp(-\lambda t)$$

radioactive decay

$$\lambda = \frac{\ln 2}{t_{\frac{1}{2}}}$$

decay constant

## 3

- 1 The drag coefficient  $C_d$  is a number with no units. It is used to compare the drag on different cars at different speed.  $C_d$  is given by the equation

$$C_d = \frac{2F}{v^n \rho A}$$

where  $F$  is the drag force on the car,  $\rho$  is the density of the air,  $A$  is the cross-sectional area of the car and  $v$  is the speed of the car.

What is the value of  $n$ ?

- A 1                                      B 2                                      C 3                                      D 4
- 2 The radius of the Earth is approximately  $6.4 \times 10^6$  m, and the radius of the moon is approximately  $1.7 \times 10^6$  m. A student wishes to build a scale model of the Solar System in the classroom, using a football of radius 0.12 m to represent the Earth.
- Which object would best represent the Moon?
- A basketball                      B cherry                      C golf ball                      D tennis ball
- 3 A passenger in a car travelling due East at speed  $v_C$  sees a motorcyclist travelling due North-West at speed  $v_M$ .

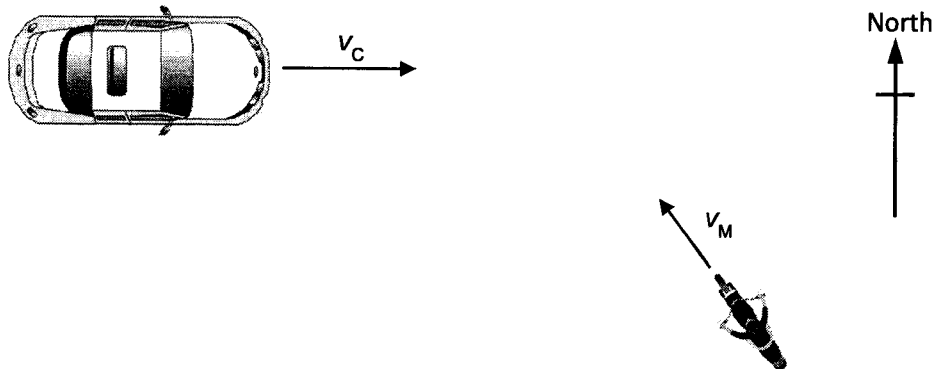

Which diagram shows the velocity  $v_R$  of the motorcyclist relative to the passenger in the car?

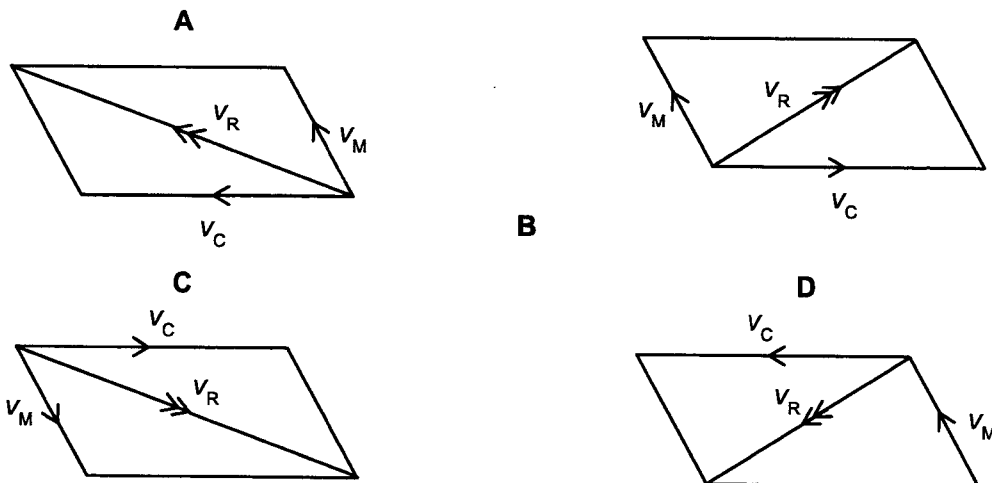

[Turn over

- 4 Two small identical objects P and Q are released from rest from the top of a building 80 m above the ground. Q is released 1.0 s after P. Neglecting air resistance, what is the maximum vertical separation between P and Q in the air?

A 5.0 m                      B 10 m                      C 35 m                      D 45 m

- 5 A small object at O is kept in static equilibrium by a horizontal thread OA and a light spring OB which makes an angle  $\theta$  with the vertical as shown below.

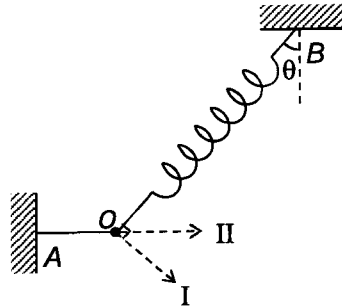

If the thread is suddenly cut, what are the direction and magnitude of the acceleration of the object at that instant?

	Direction	Magnitude
A	I	$g \sin \theta$
B	I	$g \tan \theta$
C	II	$g \sin \theta$
D	II	$g \tan \theta$

6

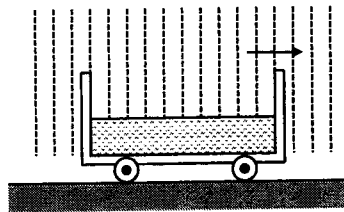

The above figure shows an open wagon moving with negligible resistance in vertically falling rain. An appreciable amount of rain falls into the wagon and accumulates there. What are the effects of the accumulating rain on the speed, momentum and kinetic energy of the wagon? (Ignore the effects of the raindrops hitting the front of the wagon.)

	speed	momentum	Kinetic energy
A	decrease	unchanged	unchanged
B	decrease	unchanged	decrease
C	decrease	decrease	decrease
D	unchanged	unchanged	Unchanged

- 7 An uneven rod is supported from a peg by means of a string. The friction force between the peg and the string is negligible.

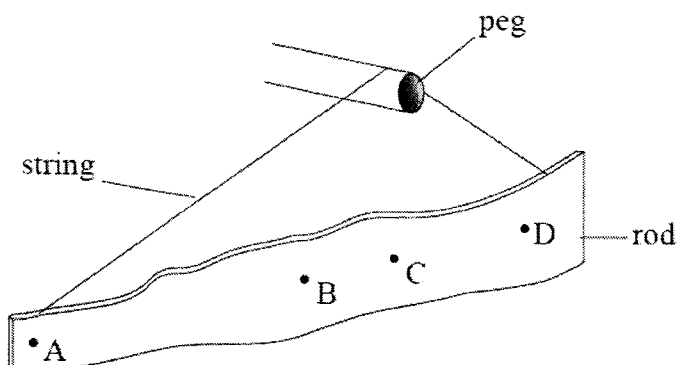

Which of the points best shows the position of the centre of gravity of the rod?

- 8 The force diagram shows an aircraft accelerating. At the instant shown, the velocity of the aircraft is  $40 \text{ m s}^{-1}$ .

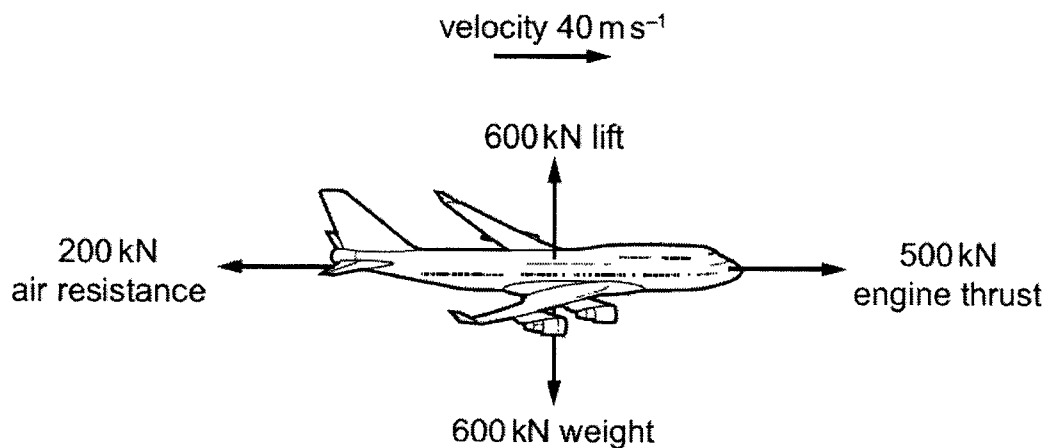

At what rate is its kinetic energy increasing?

- A 2.4 MW      B 8.0 MW      C 12 MW      D 20 MW

[Turn over

6

- 9 The figure shows a pendulum bob swinging between positions  $x$  and  $y$ .

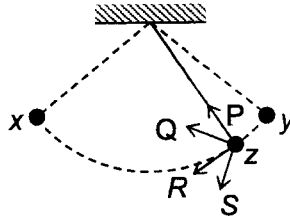

Which of the arrows  $P$ ,  $Q$ ,  $R$ ,  $S$  represents the direction of the resultant force acting on the bob when the bob is at position  $z$ ? (Neglect air resistance.)

- A  $P$                       B  $Q$                       C  $R$                       D  $S$

- 10 A car is travelling on a road in hilly terrain, as shown in diagram below. The tops and bottoms of the hill have radius of curvature  $R$ .



Assuming that the car is moving with a speed  $v$ , at which point of the hill and at what speed is the driver of the car most likely to feel weightless?

- A at the top of a hill when  $v > \sqrt{gR}$   
 B at the bottom of a hill when  $v > \sqrt{gR}$   
 C at the top of a hill when  $v < \sqrt{gR}$   
 D at the bottom of a hill when  $v < \sqrt{gR}$
- 11 Four planets A, B, C and D have masses and radii as listed in terms of  $M$  and  $R$  where  $M$  and  $R$  are the mass and radius of the Earth respectively.

Which planet would have a surface escape speed which is the same as that of the Earth?

	mass of planet	radius of planet
A	$\frac{1}{2}M$	$\frac{1}{\sqrt{2}}R$
B	$\frac{1}{2}M$	$R$
C	$M$	$\frac{1}{2}R$
D	$2M$	$2R$

- 12 An external agent does 50 J of work in moving a mass of 2.0 kg from point A to point B in a gravitational field, and  $-60$  J of work in moving the mass from point B to point C. Finally, the external agent does work of 1000 J in moving the mass from point C to infinity.

What is the gravitational potential at point A?

- A  $-555 \text{ J kg}^{-1}$   
B  $-505 \text{ J kg}^{-1}$   
C  $-495 \text{ J kg}^{-1}$   
D  $-445 \text{ J kg}^{-1}$
- 13 To cool down the electrical generator of a nuclear power plant, cold water enters the heat exchanger of the generator at  $3^\circ\text{C}$  and leaves at  $11^\circ\text{C}$ . The rate of heat removed by the water is  $4.0 \times 10^{11}$  J per hour. The specific heat capacity of water is  $4200 \text{ J kg}^{-1} \text{ K}^{-1}$ .

What is the rate of water flow?

- A  $\frac{4.0 \times 10^{11}}{4200 \times 8 \times 60 \times 60} \text{ kg s}^{-1}$   
B  $\frac{4.0 \times 10^{11} \times 60 \times 60}{4200 \times 8} \text{ kg s}^{-1}$   
C  $\frac{4.0 \times 10^{11}}{4200 \times 8 \times 60} \text{ kg s}^{-1}$   
D  $\frac{4.0 \times 10^{11} \times 60}{4200 \times 8} \text{ kg s}^{-1}$

[Turn over

- 14 Some sand is placed on a flat horizontal plate and the plate is made to oscillate with simple harmonic motion in a vertical  $x$ -direction, as shown. The amplitude of oscillation  $x_0$  of the plate is such that the maximum acceleration is equal to the acceleration of free fall.

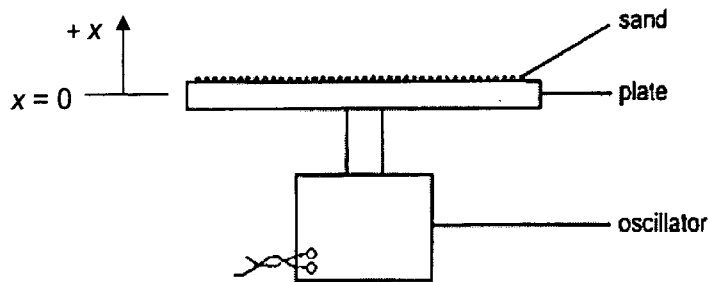

Which of the following graphs correctly describes the variation of the normal contact force  $N$  that the plate exerts on a grain of sand of mass  $m$ , with respect to the vertical displacement  $x$  of the plate?

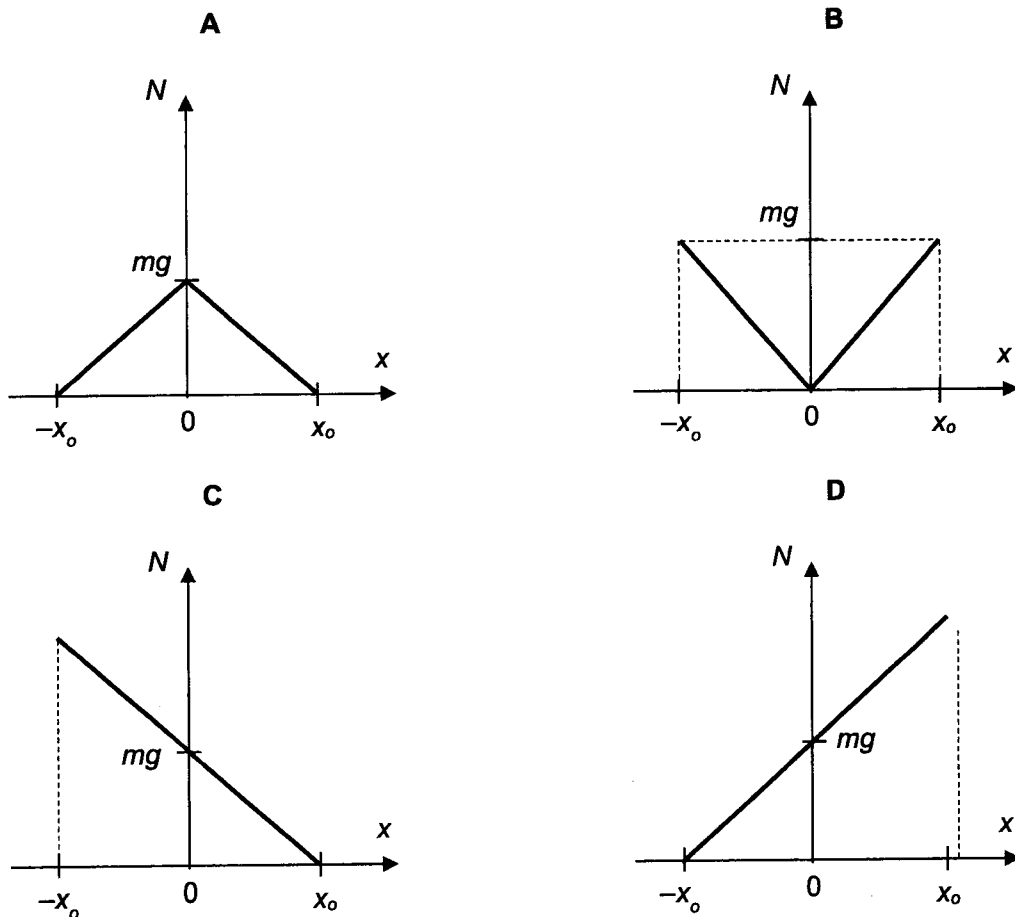

- 15 A small mass suspended at the end of a helical spring is given a vertical displacement of 3.0 cm from its rest position and then released. The subsequent simple harmonic oscillation produced has a period of 2.0 s.

What is the distance moved by the mass in the first 0.75 s?

- A 1.5 cm      B 2.1 cm      C 4.5 m      D 5.1 cm



- 16 Humans are able to detect the general direction of a sound source because sound waves from the source reaches the left and right ears at slightly different times.

The figure shows the top view of a human head with the two ears 22 cm apart. Sound waves of wavelength 1.7 m from a distant source reach the ears at an angle of  $25^\circ$  to the horizontal.

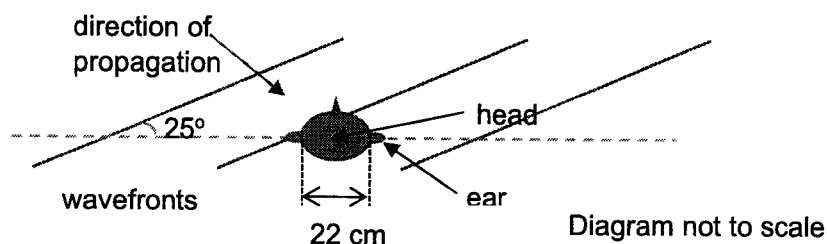

What is the phase difference between the waves reaching the left and right ear?

- A 0.34 rad      B 0.58 rad      C 0.74 rad      D 0.81 rad
- 17 The diagram shows a wave travelling from left to right at a frequency of 200 Hz. Two particles in the wave labelled X and Y are separated by a distance of 50 m.



Which of the following statement is correct?

- A At X, the air pressure is minimum.  
 B At Y, it is a position of antinode.  
 C At X, the air molecule is moving to the right.  
 D At Y, the air molecule is momentarily at rest.
- 18 A microwave transmitter emits waves that are incident normally on a reflector. A microwave detector is initially at the point M where it detects a maximum intensity. As it moves along the line PQ towards Q, the detector picks up a series of maximum and minimum intensity signals.

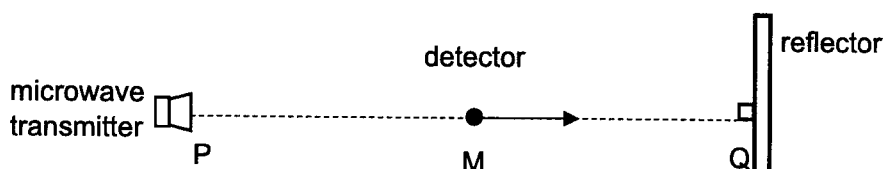

The detector moves with a speed of  $2.0 \text{ m s}^{-1}$  and the frequency at which maximum intensity signals are picked up is 10 Hz.

What is the distance moved by the detector from its initial position at M to a position where it detects the second minimum intensity signal?

- A 0.10 m      B 0.20 m      C 0.30 m      D 0.40 m

[Turn over

- 19 Two parallel plates are arranged as shown, with the right plate being earthed and the left plate at a negative potential,  $-V$ .

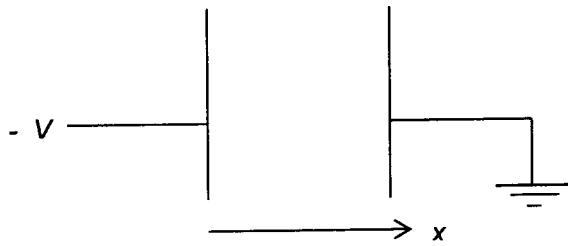

An electron is released from rest from the surface of the left plate and travels to the right plate.

The graphs below show the variations with displacement  $x$  of two quantities  $Y$  and  $Z$  of the electron as it moves from the left plate to the right plate.



Which one of the following quantities could  $Y$  and  $Z$  represent for the electron?

	quantity $Y$	quantity $Z$
<b>A</b>	speed	electric potential energy
<b>B</b>	speed	electric force
<b>C</b>	kinetic energy	electric potential energy
<b>D</b>	kinetic energy	electric force

- 20 Two identical electrical sources are used to operate a lamp of resistance  $R$  as shown in the figure below. The internal resistance of each electrical source is  $r$ .

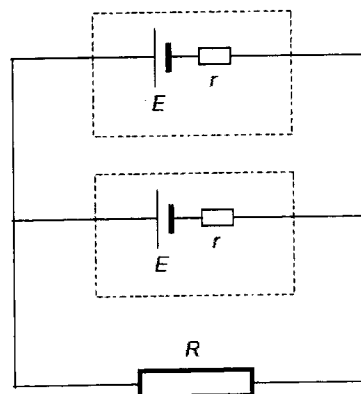

What is the fraction of the total power lost in the internal resistance of both sources?

- A**  $\frac{2R-r}{2R}$       **B**  $\frac{2R+r}{2R}$       **C**  $\frac{r}{2R+r}$       **D**  $\frac{2R}{2R+r}$

- 21 A circuit consisting of diodes  $D_1$  and  $D_2$  and resistors  $R_1$ ,  $R_2$  and  $R_3$  is shown below.

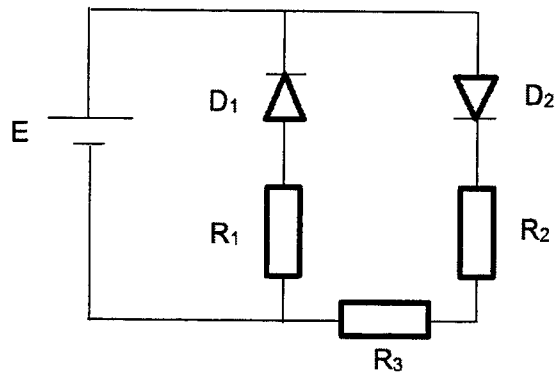

Which is the correct relative magnitude (from greatest to the smallest) of the potential differences across the components  $D_1$ ,  $R_1$  and  $R_2$ ?

	Greatest		Smallest
A	$D_1$	$R_1$	$R_2$
B	$D_1$	$R_2$	$R_1$
C	$R_1$	$R_2$	$D_1$
D	$R_2$	$R_1$	$D_1$

- 22 A variable resistor dissipates a certain power when a steady current  $I$  flows through it. The resistance had to be halved to obtain the same power dissipation in the resistor when a sinusoidal alternating current is used with a diode in series with the resistor in the circuit.

What is the peak value of the alternating current?

- A  $I$                       B  $1.4 I$                       C  $2 I$                       D  $2.8 I$

- 23 The figure below shows four long, straight current-carrying wires P, Q, R and S which are perpendicular to the plane of the paper. They pass through the corners of a square. Point O is the point of intersection of the diagonals of the square. The currents in all four wires have the same magnitude. The currents in wires P, Q and R flow into the plane of the paper while that in S flows out of the plane of the paper.

Which arrow shows the direction of the resultant magnetic field at O?

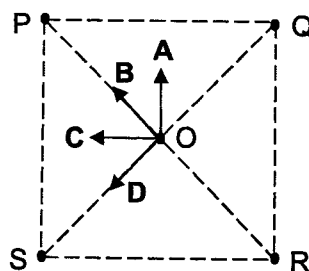

[Turn over

- 24 Two very long, straight, parallel wires carry equal steady current  $I$  in opposite directions. The distance between the wires is  $d$ . At a certain instant of time, a point charge  $q$  is at a point equidistant from the two wires, in the plane of the wires. Its instantaneous velocity  $v$  is perpendicular to this plane. The magnitude of the force due to the magnetic field acting on the charge at this instant is

- A 0 N      B  $\frac{\mu_0 I q v}{2\pi d}$       C  $\frac{\mu_0 I q v}{\pi d}$       D  $\frac{2\mu_0 I q v}{\pi d}$

- 25 A magnetic field of flux density  $4.0 \times 10^{-4}$  T passes through a coil of wire of 50 turns and an area of  $30 \text{ cm}^2$ . The field makes an angle of  $60^\circ$  with the horizontal plane of the coil.

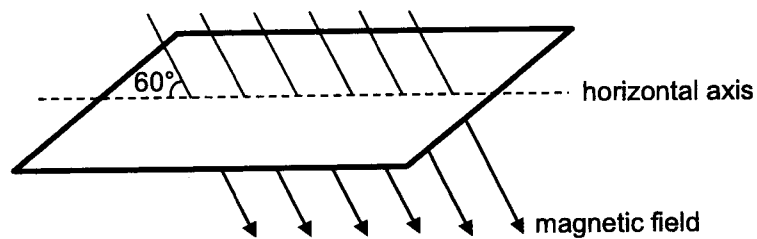

What is the e.m.f. induced in the coil when it is turned over once about its horizontal axis in a time of 0.60 s?

- A  $5.0 \times 10^{-5}$  V      B  $8.7 \times 10^{-5}$  V      C  $1.0 \times 10^{-4}$  V      D  $1.7 \times 10^{-4}$  V
- 26 Fig. 26 (a) shows two concentric circular conductors lying in the same plane. The current in the outer loop is clockwise and changes with time as shown in Fig. 26 (b).

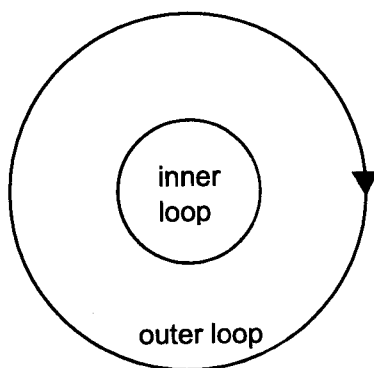

Fig. 26 (a)

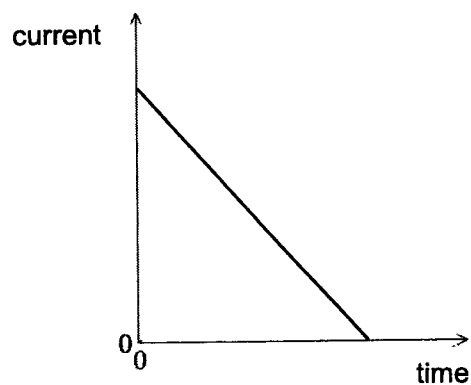

Fig. 26 (b)

The induced current in the inner loop is

- A constant in the clockwise direction.  
 B variable in the clockwise direction.  
 C constant in the anticlockwise direction.  
 D variable in the anticlockwise direction.

- 27 When electrons with velocity  $v$  travel through a vacuum and are incident on a thin carbon film, they produce a pattern of concentric circles on the fluorescent screen.

What causes the pattern and how would the pattern change when the velocity  $v$  is decreased?

	cause	change to pattern
<b>A</b>	refraction	diameters of circles decrease
<b>B</b>	refraction	diameters of circles increase
<b>C</b>	diffraction	diameters of circles decrease
<b>D</b>	diffraction	diameters of circles increase

- 28 Light quanta each of energy  $3.5 \times 10^{-19}$  J fall on the cathode of a photocell. The current through the cell is just reduced to zero by applying a reverse voltage to make the cathode 0.25 V positive with respect to the anode.

The minimum energy required to remove an electron from the cathode is

- A**  $2.9 \times 10^{-19}$  J  
**B**  $3.1 \times 10^{-19}$  J  
**C**  $3.5 \times 10^{-19}$  J  
**D**  $3.9 \times 10^{-19}$  J

- 29 Consider the following nuclear reaction:

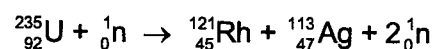

Data:

binding energy per nucleon of  ${}_{92}^{235}\text{U} = 7.59$  MeV

binding energy per nucleon of  ${}_{45}^{121}\text{Rh} = 8.26$  MeV

binding energy per nucleon of  ${}_{47}^{113}\text{Ag} = 8.52$  MeV

What is the energy change in this reaction?

- A** 73.9 MeV of energy is released.  
**B** 73.9 MeV of energy is absorbed.  
**C** 179 MeV of energy is released.  
**D** 179 MeV of energy is absorbed.

[Turn over

- 30** A radioactive source in the laboratory has a half-life of 10 days. The count rate was measured to be 100 Bq initially. 20 days later, the count rate was found to be 34 Bq.

What is the count rate in the laboratory without the source?

**A** 9 Bq

**B** 12 Bq

**C** 17 Bq

**D** 22 Bq

**End of Paper**

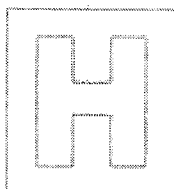

**TEMASEK JUNIOR COLLEGE**  
**2022 JC2 Preliminary Examination**  
**Higher 2**

NAME

CG

**PHYSICS****9749/02**

Paper 2 Structured Questions

**23 August 2022****2 hours****READ THESE INSTRUCTIONS FIRST**

Write your name and civics group in the spaces at the top of this page.

Write in dark blue or black pen on both sides of the paper.

You may use an HB pencil for any diagrams or graphs.

Do not use staples, paper clips, glue or correction fluid.

The use of an approved scientific calculator is expected, where appropriate.

Answer **all** questions

The number of marks is given in brackets [ ] at the end of each question or part question.

For Examiner's Use	
1	
2	
3	
4	
5	
6	
7	
s.f	
<b>Total</b>	

This booklet consists of **20** printed pages

**Data**

speed of light in free space	$c = 3.00 \times 10^8 \text{ m s}^{-1}$
permeability of free space	$\mu_0 = 4\pi \times 10^{-7} \text{ H m}^{-1}$
permittivity of free space	$\epsilon_0 = 8.85 \times 10^{-12} \text{ F m}^{-1}$ or $(1/(36\pi)) \times 10^{-9} \text{ F m}^{-1}$
elementary charge	$e = 1.60 \times 10^{-19} \text{ C}$
the Planck constant	$h = 6.63 \times 10^{-34} \text{ Js}$
unified atomic mass constant	$u = 1.66 \times 10^{-27} \text{ kg}$
rest mass of electron	$m_e = 9.11 \times 10^{-31} \text{ kg}$
rest mass of proton	$m_p = 1.67 \times 10^{-27} \text{ kg}$
molar gas constant	$R = 8.31 \text{ J K}^{-1} \text{ mol}^{-1}$
the Avogadro constant	$N_A = 6.02 \times 10^{23} \text{ mol}^{-1}$
the Boltzmann constant	$k = 1.38 \times 10^{-23} \text{ J K}^{-1}$
gravitational constant	$G = 6.67 \times 10^{-11} \text{ N m}^2 \text{ kg}^{-2}$
acceleration of free fall	$g = 9.81 \text{ m s}^{-2}$

**Formulae**

uniformly accelerated motion	$s = ut + \frac{1}{2}at^2$
	$v^2 = u^2 + 2as$
work done on/by a gas	$W = p \Delta V$
hydrostatic pressure	$p = \rho gh$
gravitational potential	$\phi = -Gm/r$
temperature	$T/\text{K} = T/^\circ\text{C} + 273.15$
pressure of an ideal gas	$p = \frac{1}{3} \frac{Nm}{V} \langle c^2 \rangle$
mean translational kinetic energy of an ideal gas molecule	$E = \frac{3}{2}kT$
displacement of particle in s.h.m.	$x = x_0 \sin \omega t$
velocity of particle in s.h.m.	$v = v_0 \cos \omega t$
	$= \pm \omega \sqrt{(x_0^2 - x^2)}$
electric current	$I = Anvq$
resistors in series	$R = R_1 + R_2 + \dots$
resistors in parallel	$1/R = 1/R_1 + 1/R_2 + \dots$
electric potential	$V = \frac{Q}{4\pi\epsilon_0 r}$
alternating current/voltage	$x = x_0 \sin \omega t$
magnetic flux density due to a long straight wire	$B = \frac{\mu_0 I}{2\pi d}$
magnetic flux density due to a flat circular coil	$B = \frac{\mu_0 NI}{2r}$
magnetic flux density due to a long solenoid	$B = \mu_0 nI$
radioactive decay	$x = x_0 \exp(-\lambda t)$
decay constant	$\lambda = \frac{\ln 2}{t_{1/2}}$

DO NOT WRITE IN THIS MARGIN

DO NOT WRITE IN THIS MARGIN



Answer all the questions in the spaces provided.

- 1 A propeller driven boat of mass 800 kg is traveling in still water in a straight line. When the boat is moving at a constant speed of  $15 \text{ m s}^{-1}$ , the power delivered to the propeller is 90 kW.

(a) Calculate the total resistive force on the boat.

total resistive force = ..... N [2]

(b) If the power delivered is then suddenly increased to 120 kW, determine the initial acceleration of the boat.

initial acceleration = .....  $\text{m s}^{-2}$  [2]

(c) Explain how the acceleration will vary over time as the power is maintained at 120 kW.

.....

.....

.....

.....

..... [4]

.....

DO NOT WRITE IN THIS MARGIN

DO NOT WRITE IN THIS MARGIN

[Turn over]

2 (a) A star and a planet orbit their mutual centre of mass as shown in Fig. 2.1. The diagram is not to scale.

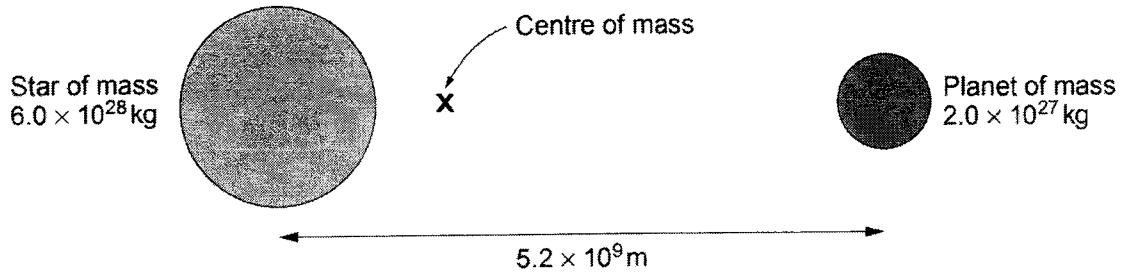

Fig. 2.1

(i) Calculate the distance of the centre of mass from the centre of the star. Explain your working clearly.

DO NOT WRITE IN THIS MARGIN

DO NOT WRITE IN THIS MARGIN

distance = ..... m [2]

(ii) Calculate the period of orbit.

period = ..... s [2]

(iii) Astronomers note a periodic dip in the brightness of the star as shown in Fig. 2.2.

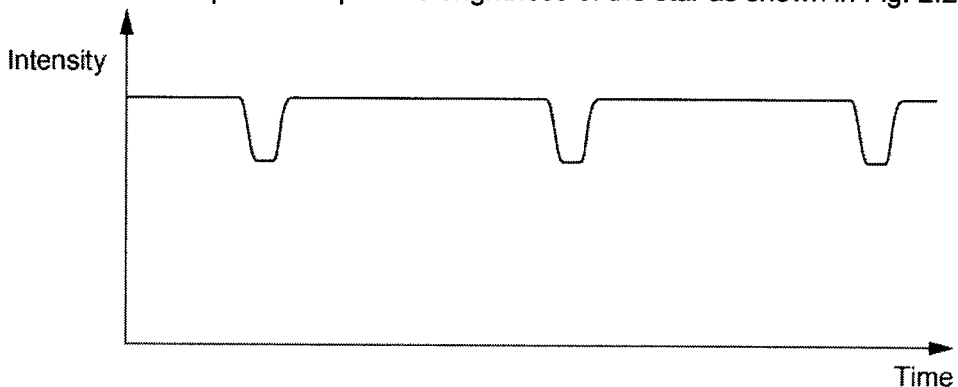

Fig. 2.2

Explain this observation.

.....

.....

..... [1]

(b) The satellite NOAA-20 was launched in November 2017. The satellite has an approximately circular orbit at an altitude of 825 km above the Earth's surface. The radius of the Earth =  $6.4 \times 10^6$  m.

Fig. 2.3 shows how the gravitational field strength  $g$  of the Earth varies with distance  $r$  from the centre of the Earth.

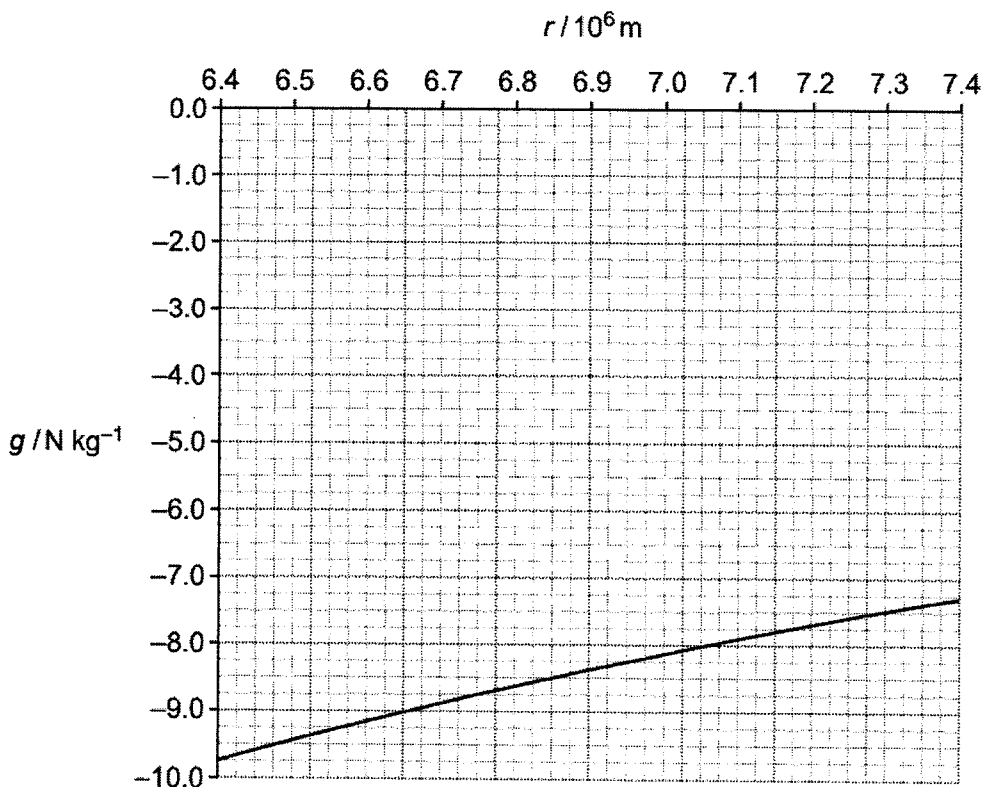

Fig. 2.3

DO NOT WRITE IN THIS MARGIN

DO NOT WRITE IN THIS MARGIN

[Turn over]

- (i) The mass of the satellite is 2300 kg. Use the graph to show that the change in gravitational potential energy of the satellite between its launch and its position in orbit is about  $1.6 \times 10^{10}$  J. Explain your working clearly.

[3]

- (ii) Use the value for the change in potential energy from (b)(i) to determine the mass of the Earth.

mass of Earth = .....kg [2]

- (iii) The satellite takes a polar orbit, revolving around the Earth from pole to pole, as shown in Fig. 2.4. Geostationary satellites orbit at a greater distance from the Earth.

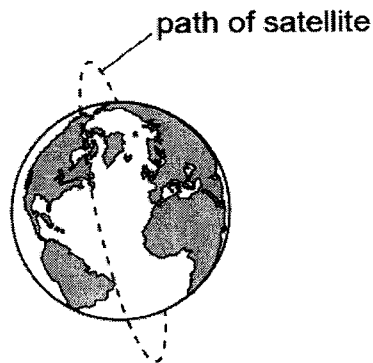

Fig. 2.4

DO NOT WRITE IN THIS MARGIN

DO NOT WRITE IN THIS MARGIN

Explain why a low, polar orbit is useful for satellites used for weather forecasting and suggest why geostationary satellites are used for telecommunications

.....

.....

.....

..... [2]

- 3 A diffraction grating is set up at the centre of a rotating table which completes a revolution in every 3.0 s. The grating is illuminated normally by monochromatic light of wavelength  $\lambda$  from a source which is also mounted on the table as shown in Fig. 3.1.

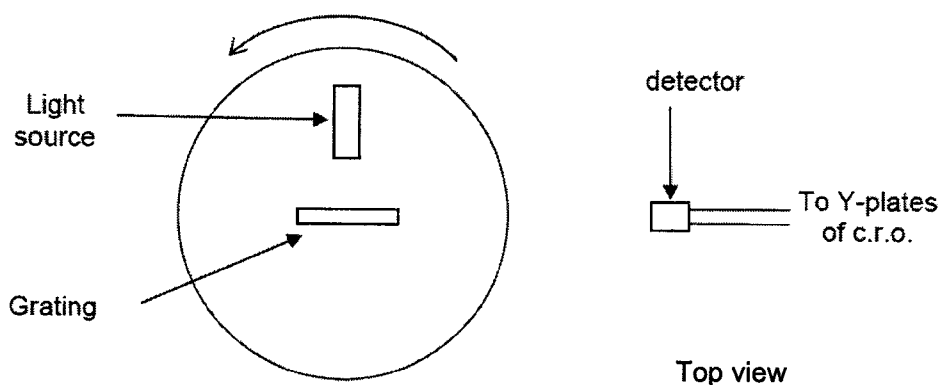

Fig. 3.1

The emergent beams of light from the grating are monitored by means of a stationary detector. The output from the detector is displayed on a cathode ray oscilloscope (c.r.o.). With the time-base set at  $0.10 \text{ s cm}^{-1}$ , the trace obtained is shown in Fig. 3.2. The relative positions of the peaks are as indicated.

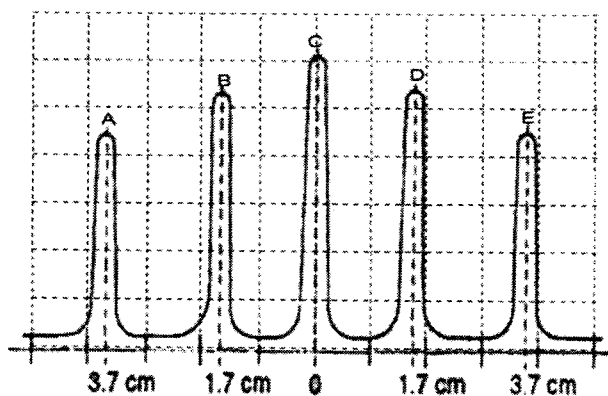

Fig. 3.2

[Turn over]

(a) Calculate the angular speed of rotation of the grating.

angular speed = ..... rad s<sup>-1</sup> [1]

(b) Explain why the peaks in Fig. 3.2 do not have the same intensity.

.....  
.....  
.....  
..... [2]

(c) (i) If  $\theta$  is the angle between the emergent ray and the normal. Use your answer in (a), determine  $\theta$  for peak E.

$\theta =$  ..... radian [2]

(ii) Using peak E, hence calculate the wavelength of the light if the grating has 550 lines per mm.

wavelength = ..... nm [2]

(iii) Explain why

1. it is preferable to calculate the wavelength using peak E rather than peak D.

.....  
.....  
..... [1]

DO NOT WRITE IN THIS MARGIN

DO NOT WRITE IN THIS MARGIN

2. only 5 peaks are observed with some calculations.

.....  
 ..... [2]

(d) Sketch, in Fig. 3.2, the trace on the c.r.o, if the diffraction grating is replaced by a double slit of the same slit separation and slit width as the diffraction grating.

[1]

4 The variation with potential difference  $V$  of current  $I$  for a light emitting diode (LED) is shown in Fig. 4.1.

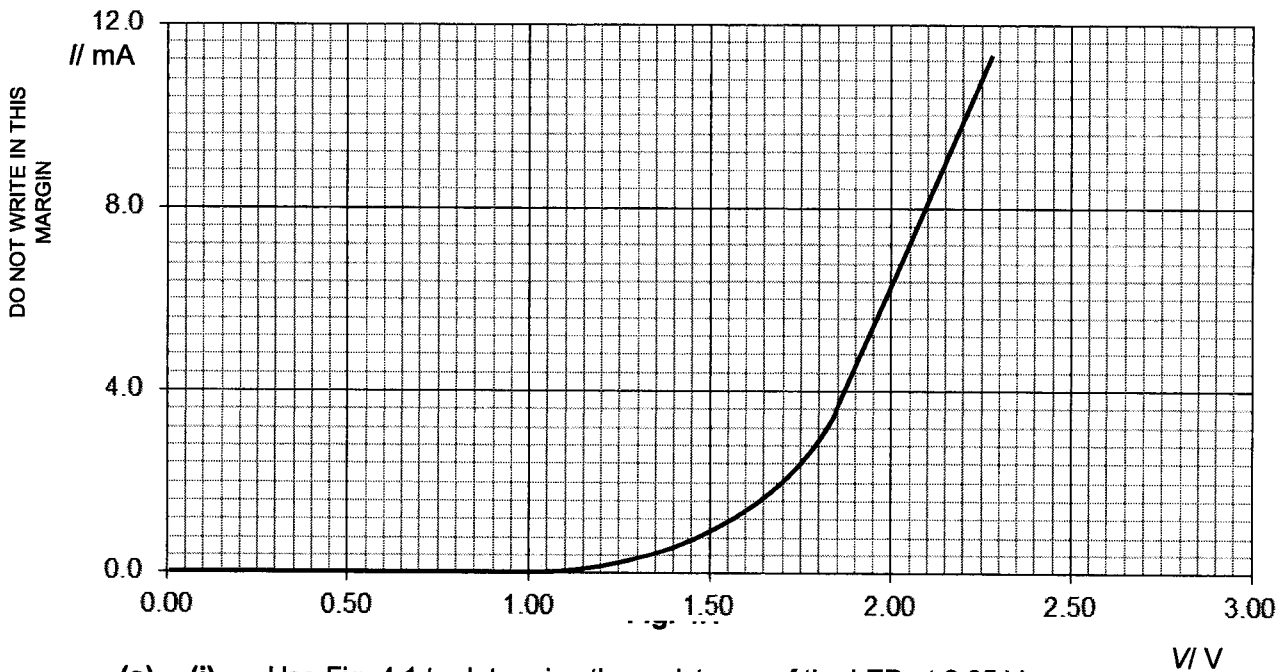

DO NOT WRITE IN THIS MARGIN

DO NOT WRITE IN THIS MARGIN

(a) (i) Use Fig. 4.1 to determine the resistance of the LED at 2.25 V.

resistance = .....  $\Omega$  [1]

[Turn over]

- (ii) Shade in Fig. 4.1 the area that represent the increase in power dissipation in the LED if the potential difference across the LED is increased from 1.50 V to 1.75 V.

[1]

- (b) Two of these LEDs are connected to a 3.0 V battery with negligible internal resistance and a  $160\ \Omega$  resistor as shown in Fig. 4.2.

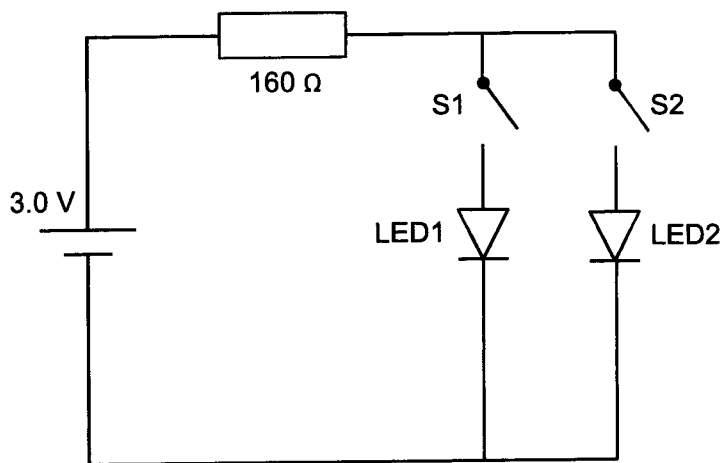

Fig. 4.2

- (i) Draw in Fig. 4.1 the variation with potential difference of current for the  $160\ \Omega$  resistor. Label the line **R**
- (ii) Hence, or otherwise, determine the current in LED1 when switch S1 is closed and switch S2 remaining open. Show your working clearly.

current = ..... mA [2]



(iii) Explain why LED1 becomes dimmer when S2 is also closed.

.....

.....

.....

.....

..... [3]

(c) It is possible for LED1 to have the same brightness regardless of whether S2 is open or closed with the addition of another 160 Ω resistor and rearrangement of the circuit in Fig. 4.2.

Draw this circuit in the space below.

DO NOT WRITE IN THIS MARGIN

DO NOT WRITE IN THIS MARGIN

[1]

5 (a) A thin slice of conducting material is placed normal to a uniform magnetic field of flux density  $B$ , as shown in Fig. 5.1.

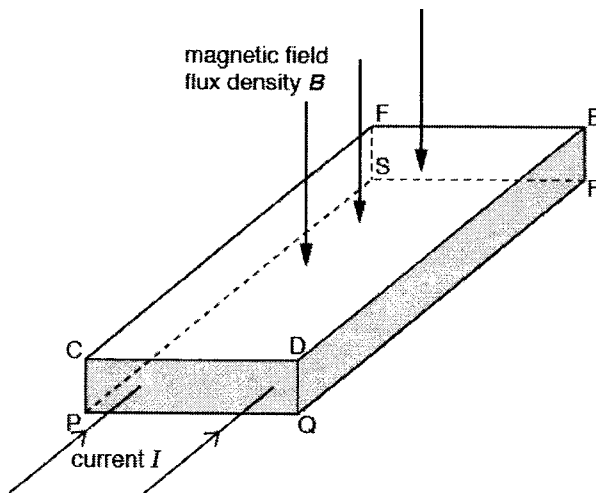

Fig. 5.1

[Turn over]

The magnetic field is normal to face CDEF and to face PQRS.

A current  $I$  passes through the slice and is normal to the faces CDQP and FERS.

A potential difference,  $V_H$ , is developed across the slice at steady state.

- (a) State the faces between which  $V_H$  is developed.

..... [1]

- (b) The current  $I$  is produced by charge carriers, each of charge  $+q$  moving at speed  $v$  in the direction of the current. The number density of the charge carriers is  $n$ .

- (i) Derive an expression relating  $V_H$  to  $v$ ,  $B$  and  $d$ , where  $d$  is one of the dimensions of the slice.

[3]

- (ii) Use your answer in (b)(i) and an expression for the current  $I$  in the slice to derive the Expression

$$V_H = \frac{BI}{ntq}$$

where  $t$  is another of the dimensions of the slice. Explain your working.

[2]

DO NOT WRITE IN THIS MARGIN

DO NOT WRITE IN THIS MARGIN

(iii) Suggest why  $V_H$  is difficult to detect in a thin slice of copper.

.....  
 .....  
 .....[1]

6 (a) The plan view (from top down) of a train braking system is illustrated in Fig 6.1. The train carriage of mass  $m$  is mounted on a rectangular metal frame ABCD of length  $L$  and width  $w$ , the effective resistance of the frame is  $R$ . The train carriage is initially moving at a constant speed along the rails.

A uniform magnetic field  $B$  is directed perpendicularly into the ground over a rectangular region of length  $L$ . Line P denotes the start of this region while line Q denotes the end of the region. After passing through the magnetic field, the train speed is expected to be reduced to a very low speed (exit speed) after which brakes can be applied to stop it completely. You may assume that friction is negligible.

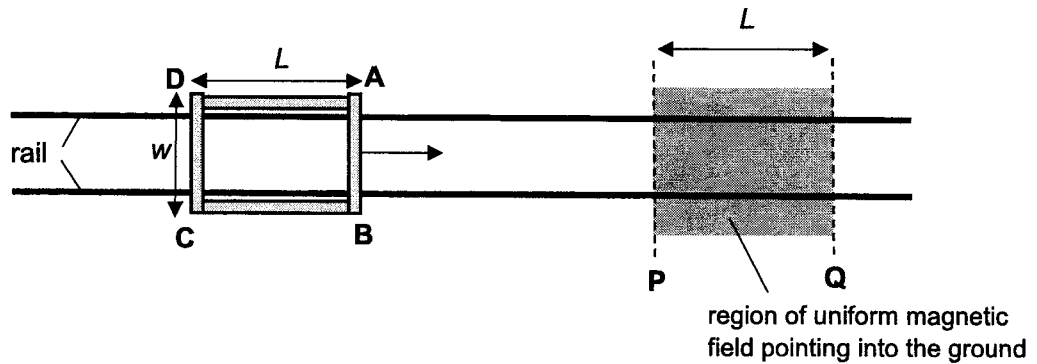

Fig 6.1

(i) Define *magnetic flux density*.

.....  
 .....  
 .....  
 .....[2]

[Turn over]

- (ii) Explain how the train carriage is slowed down as AB moves through the magnetic field from P to Q.

.....

.....

.....

.....

..... [3]

- (iii) Show that the braking force acting on the frame is given by  $F = \frac{B^2 w^2 v}{R}$  where  $v$  is the speed of the train carriage. Explain your working clearly.

DO NOT WRITE IN THIS MARGIN

DO NOT WRITE IN THIS MARGIN

[4]

- (b) The graph in Fig 6.2 shows the speed of the train carriage as it moves through the magnetic field, from the instant AB crosses line P to the instant CD crosses line Q.

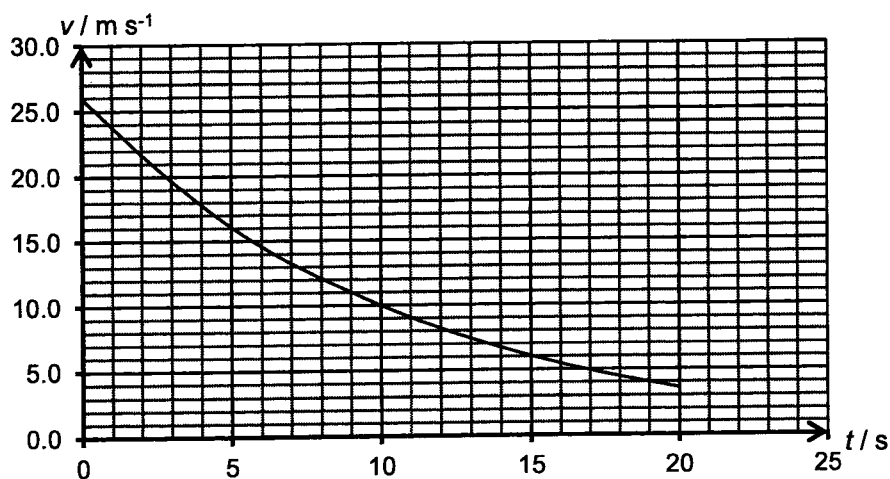

Fig 6.2

(i) Use Fig 6.2 to estimate the distance PQ.

distance PQ = .....m [2]

(ii) Discuss how increasing the region of magnetic field (distance between P and Q) would affect, if at all, the exit speed of the train after passing through it.

.....  
.....  
..... [2]

DO NOT WRITE IN THIS MARGIN

7 The Earth receives radiant energy from the Sun every second. If the Earth radiates or reflect energy back into space at the same rate, then it will be in thermal equilibrium and its average temperature will remain constant. If the Earth radiates or reflect less energy than it receives it will get hotter.

DO NOT WRITE IN THIS MARGIN

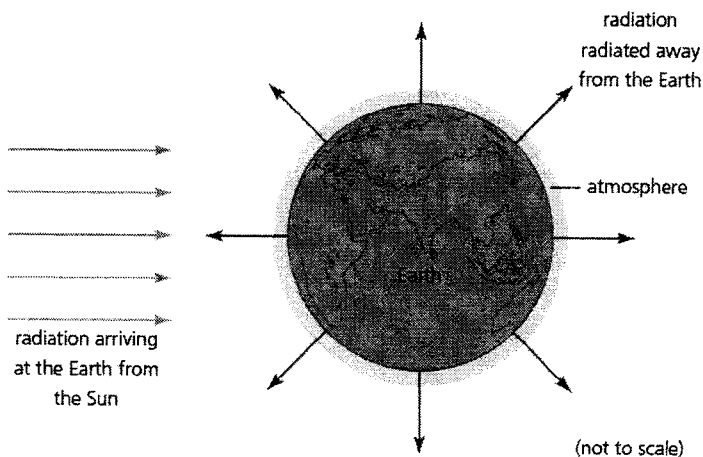

The greenhouse effect is the name that is given to the natural effect a planet's atmosphere has in increasing the temperature of the planet to a value higher than it would be without an atmosphere. The Earth has a beneficial greenhouse effect because it has an atmosphere. The Earth's atmosphere is a good transmitter of visible radiation and a good absorber of infrared radiation. The visible light that reaches the Earth's surface is absorbed and reradiated as infrared light, which in turn is absorbed (trapped) by the Earth's atmosphere.

If the Earth did not have an atmosphere it would be about 30°C cooler and without life. The Moon and the Earth are approximately the same distance from the Sun, but the surface of the Earth is hotter and therefore human life exists.

[Turn over]

However, most scientists now believe that the greenhouse effect has become enhanced. This is attributed to human activities, primarily fossil fuel burning. As fossil fuels (coal, oil, and natural gas) are burned, large amounts of carbon dioxide, which is one of the most significant greenhouse gases, are released into the atmosphere. According to one estimate, doubling the carbon dioxide content in the atmosphere will cause temperatures to increase by  $2^{\circ}\text{C}$ . This is probably the most important cause of current global warming.

There is little doubt that global warming has led to consequences such as climate change and changes to the sea level. During December 2006, New York had one of its highest temperatures for a winter while Melbourne has snow in the hinterlands during summer. Global warming is causing global mean sea level to rise in two ways. Firstly, glaciers and ice sheets worldwide are melting and secondly, the volume of the ocean is expanding as the water warms.

(a) Solar radiation falling on the Earth's surface is absorbed by the Earth.

- (i) This solar radiation has an average intensity of  $5.0 \times 10^2 \text{ Wm}^{-2}$  and falls on an area of  $2.6 \times 10^{14} \text{ m}^2$  on the Earth.

Calculate the energy per second that is absorbed by the Earth due to this solar radiation.

energy per second = .....  $\text{J s}^{-1}$  [2]

- (ii) The Earth has acquired a mean equilibrium temperature due to the energy per second absorbed from the Sun being in balance with the power radiated from the Earth's surface into Space.

State the power that must be radiated from the Earth's surface so that it achieves a steady equilibrium temperature.

power = ..... W [1]

DO NOT WRITE IN THIS MARGIN

DO NOT WRITE IN THIS MARGIN

- (iii) Assuming that the Earth radiates this power uniformly from all points on its surface and the radius of the Earth is 6400 km, show that the Earth radiates a power of 250 W per square metre of the Earth's surface

[2]

- (b) Fig. 7.1 shows the variation with wavelength,  $\lambda$ , of the intensity of electromagnetic radiation emitted by a blackbody at a surface temperature of 2900 K.

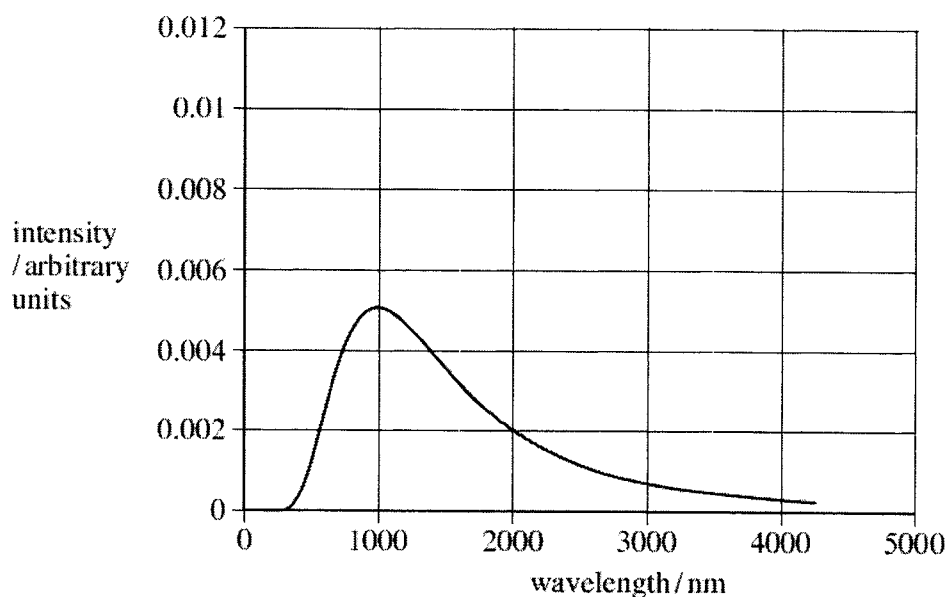

Fig. 7.1

At any surface temperature  $T$  in kelvin, there is a peak intensity corresponding to a wavelength  $\lambda_{\max}$  of radiation. The wavelength  $\lambda_{\max}$  is related to temperature  $T$  by the equation

$$\lambda_{\max} T = k$$

where  $k$  is a constant. This equation is also known as Wien's Law.

- (i) Mark, with an arrow labelled **M** on Fig. 7.1, the wavelength  $\lambda_{\max}$  that correspond to the peak intensity of radiation from the blackbody. [1]

[Turn over]

(ii) Use Fig. 7.1 to calculate the value of  $k$ .

$k = \dots\dots\dots \text{ nm K} \quad [2]$

(iii) The surface of the Sun is at a temperature of 5800 K and that of the Earth is 290 K. They may both be considered to radiate energy as black bodies.  
 Calculate the wavelengths, in nm, corresponding to the peak intensity for the radiation emitted by the Sun and the Earth.

wavelength for the Sun =  $\dots\dots\dots$  nm  
 wavelength for the Earth =  $\dots\dots\dots$  nm  $[2]$

(iv) Draw on Fig. 7.1 the emission curve for the Sun. Label it (iv).  $[1]$

(c) Fig. 7.2 shows how the percentage of electromagnetic radiation, absorbed by carbon dioxide, varies with the wavelength of the radiation.

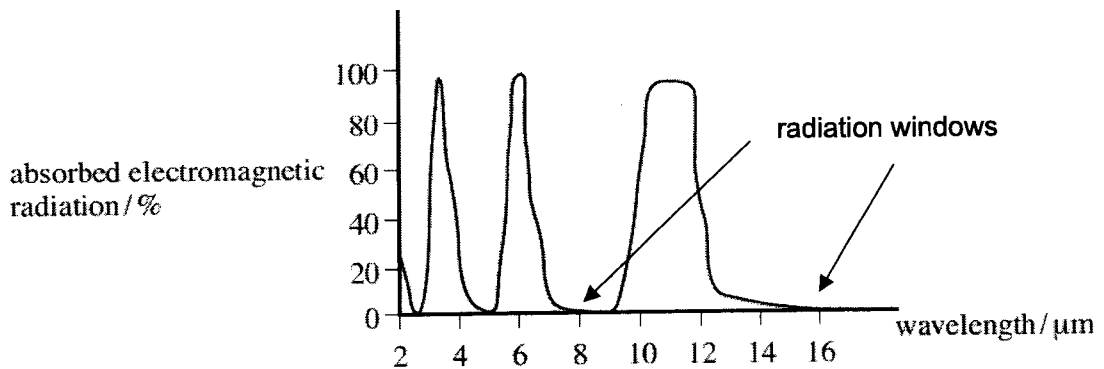

Fig. 8.2

DO NOT WRITE IN THIS MARGIN

DO NOT WRITE IN THIS MARGIN



- (i) The graph indicates that carbon dioxide has radiation windows. Suggest what is meant by the term *radiation windows* in this context.

.....

.....

..... [1]

- (ii) State whether carbon dioxide has a radiation window for radiation of wavelength 11  $\mu\text{m}$ .

.....

..... [1]

- (d) Explain how Wien's law and knowledge of the radiation windows for carbon dioxide can be used to account for the greenhouse effect that contributes to global warming.

.....

.....

.....

.....

.....

.....

..... [3]

- (e) Large proportions of the Earth's ice will melt if the Earth's equilibrium temperature increases.

- (i) Greenland has an ice sheet that covers a land area of  $1.7 \times 10^6 \text{ km}^2$ . The mass of the ice in this sheet is  $2.8 \times 10^{18} \text{ kg}$ . Calculate the volume of water produced if all of this ice were to melt. density of water =  $1.0 \times 10^3 \text{ kg m}^{-3}$

volume = .....  $\text{m}^3$  [2]

[Turn over]

DO NOT WRITE IN THIS MARGIN

DO NOT WRITE IN THIS MARGIN

- (ii) Arctic pack ice mostly consists of frozen salt water that floats on the surface of the Arctic Ocean. Until recently, this ice remained frozen but now significant amounts of it melt during the summer.  
State and explain any change in sea levels that may occur should all of this floating pack ice melt.

.....

.....

.....

.....

.....

.....

[2]

DO NOT WRITE IN THIS MARGIN

DO NOT WRITE IN THIS MARGIN

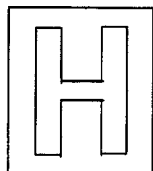

**TEMASEK JUNIOR COLLEGE**  
**2022 JC2 PRELIMINARY EXAMINATION**  
**Higher 2**



CANDIDATE  
NAME

CENTRE  
NUMBER

S				
---	--	--	--	--

INDEX  
NUMBER

--	--	--	--

**PHYSICS**

**9749/03**

**Paper 3 Longer Structured Questions**

**13 September 2022**

**2 hours**

**Candidates answer on the Question Paper.**

**No additional Materials are required.**

**READ THESE INSTRUCTIONS FIRST**

Write your name, CG and subject tutor's name on all the work you hand in.

Write in dark blue or black pen on both sides of the paper.  
 You may use an HB pencil for any diagrams or graphs.  
 Do not use staples, paper clips, glue or correction fluid.

The use of an approved scientific calculator is expected, where appropriate.

**Section A**

Answer **all** questions.

**Section B**

Answer **one** question only

You are advised to spend one and a half hour on Section A and half an hour on Section B.

The number of marks is given in brackets [ ] at the end of each question or part question.

For Examiner's Use	
1	
2	
3	
4	
5	
6	
7	
8	
s.f.	
<b>Total</b>	

This document consists of **21** printed pages and **3** blank pages.

**Data**

speed of light in free space	$c = 3.00 \times 10^8 \text{ m s}^{-1}$
permeability of free space	$\mu_0 = 4\pi \times 10^{-7} \text{ H m}^{-1}$
permittivity of free space	$\epsilon_0 = 8.85 \times 10^{-12} \text{ F m}^{-1}$ or $(1/(36\pi)) \times 10^{-9} \text{ F m}^{-1}$
elementary charge	$e = 1.60 \times 10^{-19} \text{ C}$
the Planck constant	$h = 6.63 \times 10^{-34} \text{ Js}$
unified atomic mass constant	$u = 1.66 \times 10^{-27} \text{ kg}$
rest mass of electron	$m_e = 9.11 \times 10^{-31} \text{ kg}$
rest mass of proton	$m_p = 1.67 \times 10^{-27} \text{ kg}$
molar gas constant	$R = 8.31 \text{ J K}^{-1} \text{ mol}^{-1}$
the Avogadro constant	$N_A = 6.02 \times 10^{23} \text{ mol}^{-1}$
the Boltzmann constant	$k = 1.38 \times 10^{-23} \text{ J K}^{-1}$
gravitational constant	$G = 6.67 \times 10^{-11} \text{ N m}^2 \text{ kg}^{-2}$
acceleration of free fall	$g = 9.81 \text{ m s}^{-2}$

**Formulae**

uniformly accelerated motion	$s = ut + \frac{1}{2} at^2$
	$v^2 = u^2 + 2as$
work done on/by a gas	$W = p \Delta V$
hydrostatic pressure	$p = \rho gh$
gravitational potential	$\phi = -Gm/r$
temperature	$T/K = T/^\circ\text{C} + 273.15$
pressure of an ideal gas	$p = \frac{1}{3} \frac{Nm}{V} \langle c^2 \rangle$
mean translational kinetic energy of an ideal gas molecule	$E = \frac{3}{2} kT$
displacement of particle in s.h.m.	$x = x_0 \sin \omega t$
velocity of particle in s.h.m.	$v = v_0 \cos \omega t$
	$= \pm \omega \sqrt{(x_0^2 - x^2)}$
electric current	$I = Anvq$
resistors in series	$R = R_1 + R_2 + \dots$
resistors in parallel	$1/R = 1/R_1 + 1/R_2 + \dots$
electric potential	$V = \frac{Q}{4\pi\epsilon_0 r}$
alternating current/voltage	$x = x_0 \sin \omega t$
magnetic flux density due to a long straight wire	$B = \frac{\mu_0 I}{2\pi d}$
magnetic flux density due to a flat circular coil	$B = \frac{\mu_0 NI}{2r}$
magnetic flux density due to a long solenoid	$B = \mu_0 nI$
radioactive decay	$x = x_0 \exp(-\lambda t)$
decay constant	$\lambda = \frac{\ln 2}{t_{1/2}}$

DO NOT WRITE IN THIS MARGIN

DO NOT WRITE IN THIS MARGIN

**Section A**

Answer **all** the questions in this Section in the spaces provided.

- 1 (a) A monoatomic ideal gas A is contained in an insulated cylinder to prevent the loss of heat, while monoatomic ideal gas B is contained in a cylinder without any insulation, as shown in Fig. 1.1.

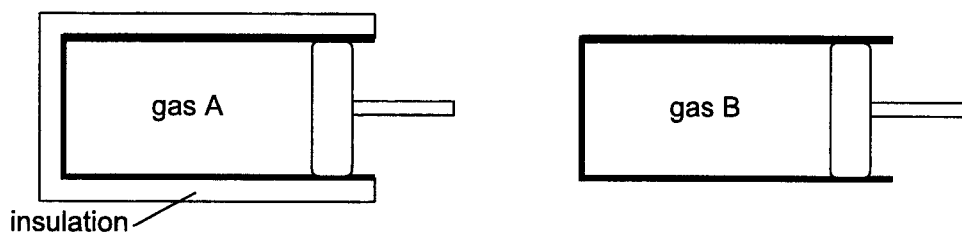

**Fig. 1.1**

Initially, the two gases have the same volume of  $2.90 \times 10^{-4} \text{ m}^3$ , the same pressure of  $1.05 \times 10^5 \text{ Pa}$  and the same temperature of  $303 \text{ K}$ .

- (i) Explain what is meant by the *internal energy* of an ideal gas.

.....  
 .....  
 .....  
 ..... [1]

- (ii) Determine the number of molecules in gas A.

number of molecules = ..... [2]

[Turn over]

DO NOT WRITE IN THIS MARGIN

DO NOT WRITE IN THIS MARGIN

(iii) Determine the mean translational kinetic energy of a molecule of gas A.

mean translational kinetic energy = ..... J [1]

(b) When gas A is compressed to a volume of  $2.10 \times 10^{-4} \text{ m}^3$ , its temperature rises to 357 K. Gas B is compressed very slowly to the same volume of  $2.10 \times 10^{-4} \text{ m}^3$ .

(i) Determine the change in internal energy of gas A during the compression.

change in internal energy = ..... J [2]

(ii) Determine the work done on gas A during the compression.

work done on the gas = ..... J [1]

(iii) On Fig. 1.2, sketch the variation with volume of the pressure of gas A and gas B. Include appropriate labels, and values of pressure and volume. [3]

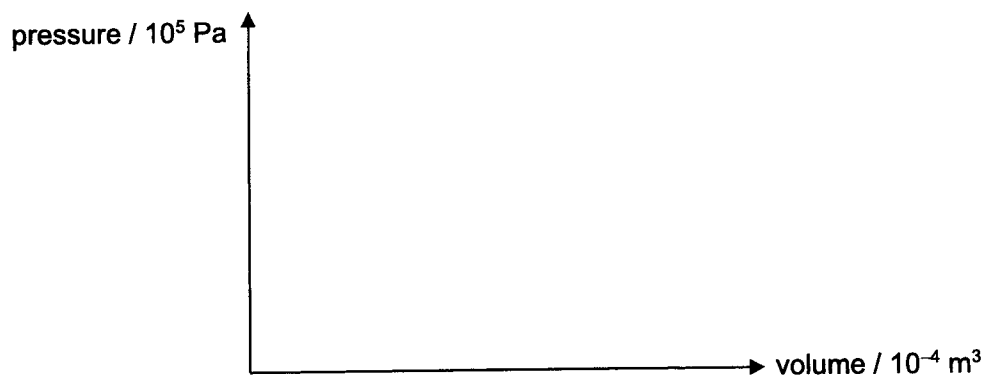

Fig.1.2

DO NOT WRITE IN THIS MARGIN

DO NOT WRITE IN THIS MARGIN

- 2 Fig. 2.1 shows a mass  $m$  attached to a spring performing *simple harmonic motion* in the vertical  $y$  direction. The spring constant  $k$  of the spring is  $61.4 \text{ N m}^{-1}$ .

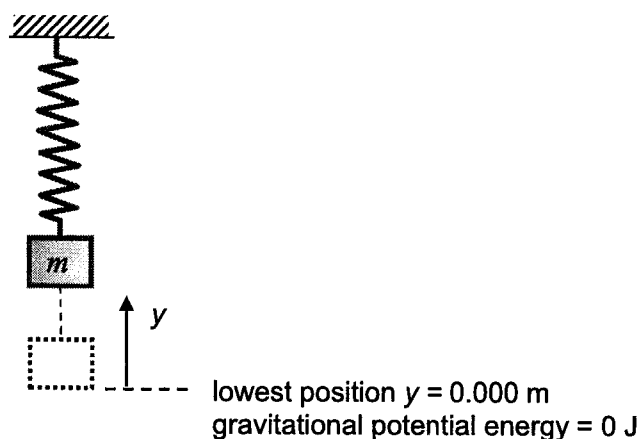

Fig. 2.1

At  $y = 0.000 \text{ m}$ , the lowest point of the oscillation, the gravitational potential energy of the system is defined as  $0 \text{ J}$ .

As the system oscillates, its total energy is a constant and comprising kinetic energy, elastic potential energy and gravitational potential energy. At different positions  $y$  above the lowest position of oscillation, the kinetic energy and the elastic potential energy of the system vary as shown in Fig. 2.2.

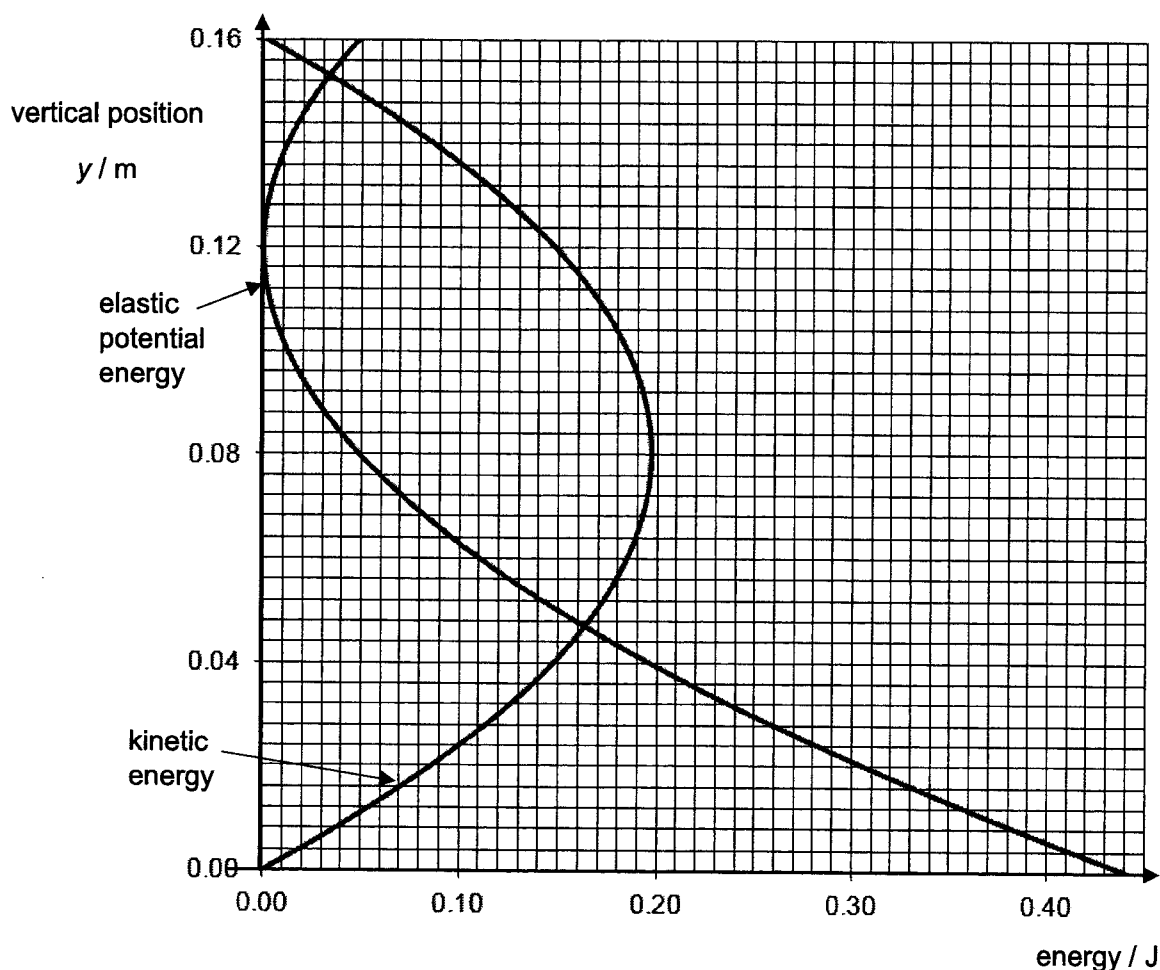

Fig. 2.2

[Turn over]

(a) Define *simple harmonic motion*.

.....

.....

.....

..... [2]

(b) Determine the total energy of the system. Show your working clearly.

total energy = ..... J [2]

(c) Sketch on Fig. 2.2 a graph showing the variation with  $y$  of the gravitational potential energy of the system. [2]

(d) Hence or otherwise, show that mass  $m$  is 0.250 kg.

$m =$  ..... kg [2]

(e) Find the period  $T$  of the oscillation.

$T =$  ..... s [2]

DO NOT WRITE IN THIS MARGIN

DO NOT WRITE IN THIS MARGIN



- 3 Fig. 3.1 shows two large, vertical parallel plates, A and B, with plate B being connected to earth. An electron was emitted perpendicularly from plate A with an initial velocity  $v$  of  $4.30 \times 10^6 \text{ m s}^{-1}$ . The electron experiences an electric force of  $1.12 \times 10^{-16} \text{ N}$  towards plate A in the region between the two plates.

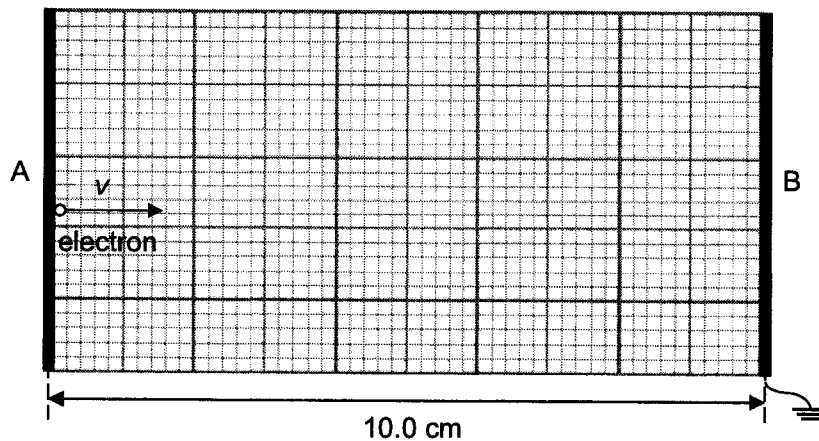

Fig. 3.1

- (a) Calculate the potential of plate A.

DO NOT WRITE IN THIS MARGIN

DO NOT WRITE IN THIS MARGIN

potential of plate A = ..... V [2]

- (b) (i) The electron comes to a stop momentarily at a point P. Use your answer in (a) to determine the potential at P.

potential at P = ..... V [2]

- (ii) On Fig. 3.1, draw the equipotential line passing through P. [2]

[Turn over]

- (c) Another electron of the same speed is now ejected from plate A towards plate B at an angle less than  $90^\circ$  to plate A. State, with a reason, whether the electron will stop before, at or beyond the equipotential line passing through P.

.....

.....

.....

..... [2]

- (d) A proton is projected with a velocity of  $3.5 \times 10^6 \text{ m s}^{-1}$  along the axis midway between two parallel plates of length 20 cm as shown in Fig. 3.2. The uniform electric field between the plates has an intensity of  $2.0 \times 10^4 \text{ N C}^{-1}$  and is directed upward.

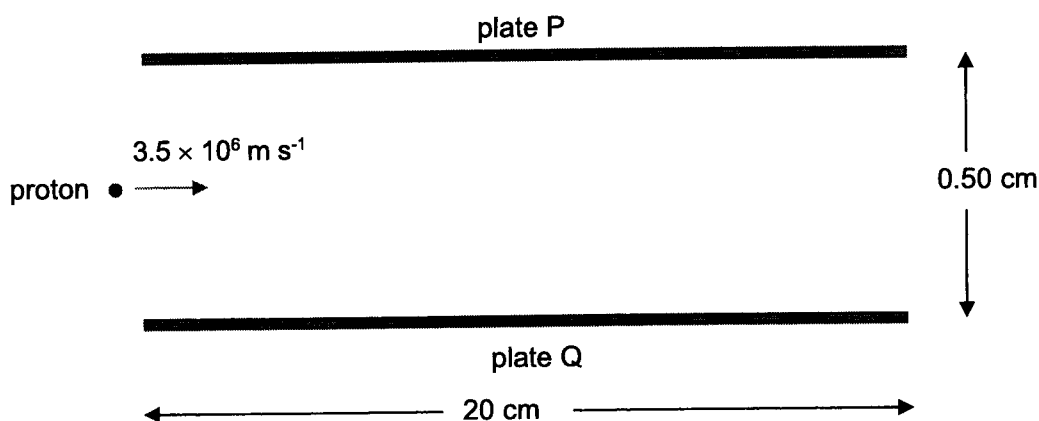

Diagram not to scale

Fig. 3.2

- (i) Determine the position where the proton will strike plate P.

proton will strike P at ..... cm from point of entry [3]

- (ii) An alpha particle that enters the electric field at the same point and with the same velocity as the proton. Describe and explain with some calculations whether the alpha particle will hit or exit the plates.

.....

.....

.....

.....

.....

.....

..... [3]

DO NOT WRITE IN THIS MARGIN

- 4 (a) For an alternating current flowing in a heating coil, the average current is zero. Explain why there is heating effect produced in the coil.

.....

.....

..... [2]

DO NOT WRITE IN THIS MARGIN

- (b) A power station needs to deliver 20.0 MW of power to a city 10.0 km away. This power is generated at 16.0 kV and then stepped up by using a transformer of turn ratio 15:1 before transmission. The resistance per unit length of the transmission cables is  $20.0 \Omega \text{ km}^{-1}$ .

The operator of the station loses \$0.10 for every kWh of electrical power lost.

- (i) Calculate the power lost during transmission.

power lost = ..... W [2]

[Turn over]

- (ii) Hence determine the amount of money saved by the station in one day when the energy is transmitted at the stepped-up voltage instead of the generated voltage.

amount saved = \$ .....

[2]

- 5 A car of weight 8500 N is travelling at constant speed along a road that is an arc of a circle. In order that the car may travel more easily round the arc, the road is banked at  $14^\circ$  to the horizontal, as shown in Figure 2.1 below.

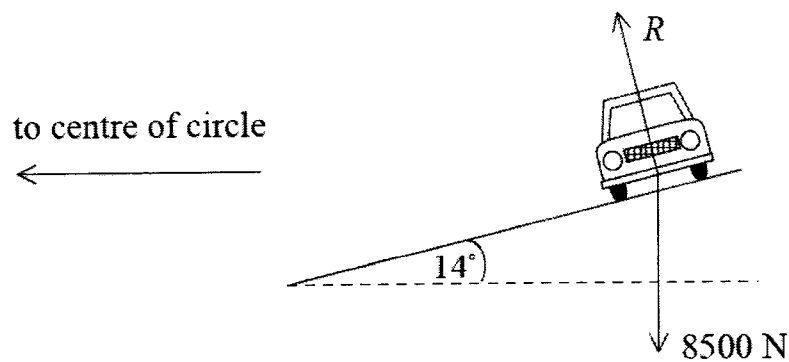

Fig. 5.1

At one particular speed  $v$  of the car, there is no frictional force at  $90^\circ$  to the direction of travel of the car between the tyres and the road surface. The reaction force of the road on the car is  $R$ .

- (a) Show that the horizontal component of the force  $R$  is approximately 2100 N.

[2]

- (b) Determine the speed  $v$  of the car at which it travels round the arc of radius 150 m without tending to slide.

speed  $v =$  ..... m s<sup>-1</sup> [2]

- (c) State and explain in which direction the car will tend to slide if it travels round the curve at a speed greater than  $v$ .

.....  
 .....  
 ..... [2]  
 .....

- 6 (a) The energy levels of a hypothetical one-electron atom are given by

$$E_n = -\frac{27.9}{n^2} \text{ eV}$$

where  $n = 1, 2, 3, \dots$

- (i) Describe how line spectra can be explained using the idea of discrete electron energy levels in isolated atoms.

.....  
 .....  
 ..... [2]  
 .....

- (ii) Explain why the energy of each energy level is negative.

.....  
 ..... [1]  
 .....

[Turn over]

- (iii) Calculate the energies of the four lowest energy levels and construct a clearly labelled energy level diagram in the space below.

[3]

- (iv) If the atoms are in the ground state and are bombarded by electrons of kinetic energy 26.5 eV, determine the highest energy level that an atom can reach. Show your working clearly.

DO NOT WRITE IN THIS  
MARGINDO NOT WRITE IN THIS  
MARGIN

highest energy level = ..... [2]

- (v) Calculate the shortest wavelength of the photons emitted when the atoms subsequently de excites.

shortest wavelength = ..... nm [2]

(b) In a modern X-ray tube, electrons are accelerated through a large potential difference and the X-rays are produced when electrons strike a metal target embedded in a large piece of copper.

The emission spectrum of the metal when it is bombarded by a beam of fast-moving electrons is shown in Fig. 6.1.

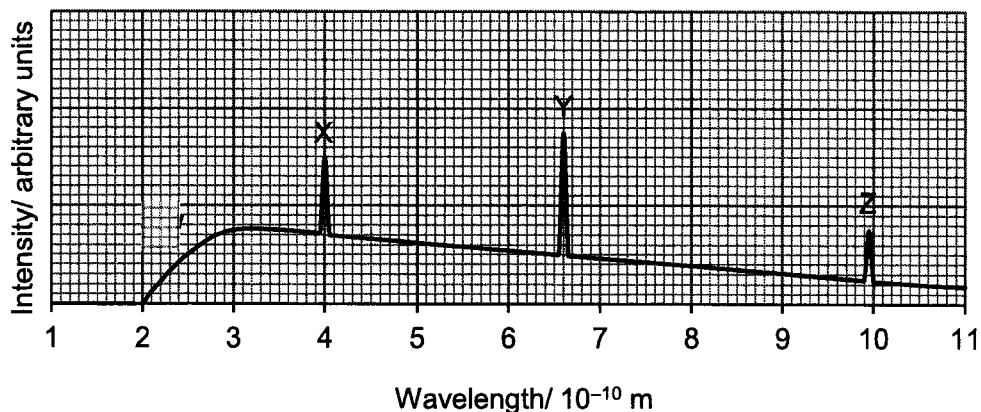

Fig. 6.1

(i) Calculate the accelerating potential of the X-ray tube.

accelerating potential = ..... V [2]

(ii) Explain why there are sharp peaks X, Y and Z in the X-ray spectrum.

.....  
 .....  
 .....  
 ..... [2]

DO NOT WRITE IN THIS MARGIN

DO NOT WRITE IN THIS MARGIN

[Turn over]

Section B

Answer one question from this Section in the spaces provided.

- 7 (a) A rocket in outer space far from any other masses is used to propel a satellite. At  $t = 0$ , the engines are turned on and gases leave the rear of the rocket with speed  $v$  relative to the rocket as shown in Figure 7.1.

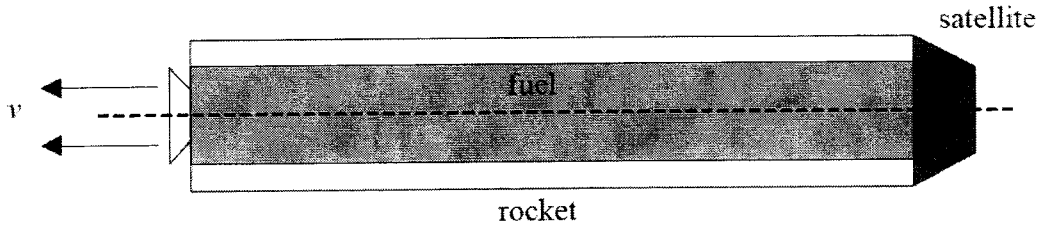

Fig. 7.1

- (i) 1. Explain, in terms of Newton's laws of motion, why the rocket will accelerate.

.....

.....

.....

..... [2]

- 2. Outline how the conservation of momentum applies to the motion of the rocket.

.....

.....

.....

..... [2]

- 3. The gases leave the rear of the rocket at a constant rate of  $R$  kg per second. The mass of the rocket (including fuel) at  $t = 0$  is  $m$ . Deduce that the initial acceleration  $a$  of the rocket is given by the expression

$$a = \frac{Rv}{m} \quad [3]$$

DO NOT WRITE IN THIS MARGIN

DO NOT WRITE IN THIS MARGIN



- (ii) Figure 7.2 below shows a two-stage rocket that is used to accelerate a satellite that has the same mass as in (i). The rocket has the same mass as the single stage rocket and carries the same mass of fuel as in (i).

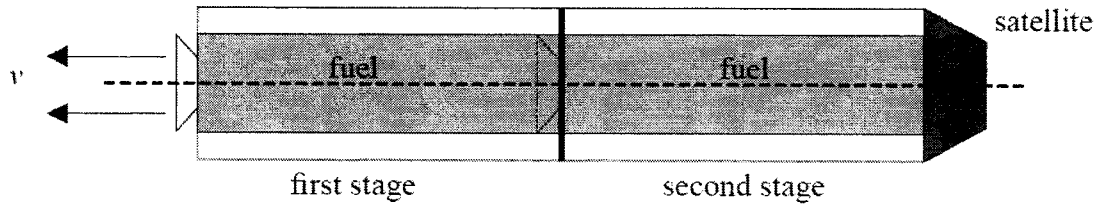

Fig. 7.2

Each stage is discarded after all its fuel has been used. Explain, using your answer to (i)3, whether the final speed of the satellite will be larger, equal or smaller than that of the satellite accelerated by the single stage rocket.

.....

.....

.....

..... [2]

DO NOT WRITE IN THIS MARGIN

DO NOT WRITE IN THIS MARGIN

- (b) A girl falls from rest on to the horizontal surface of a trampoline. Figure 7.3 below shows the variation with time  $t$  of the net force  $F$  exerted on the girl before, during and after contact with the trampoline.

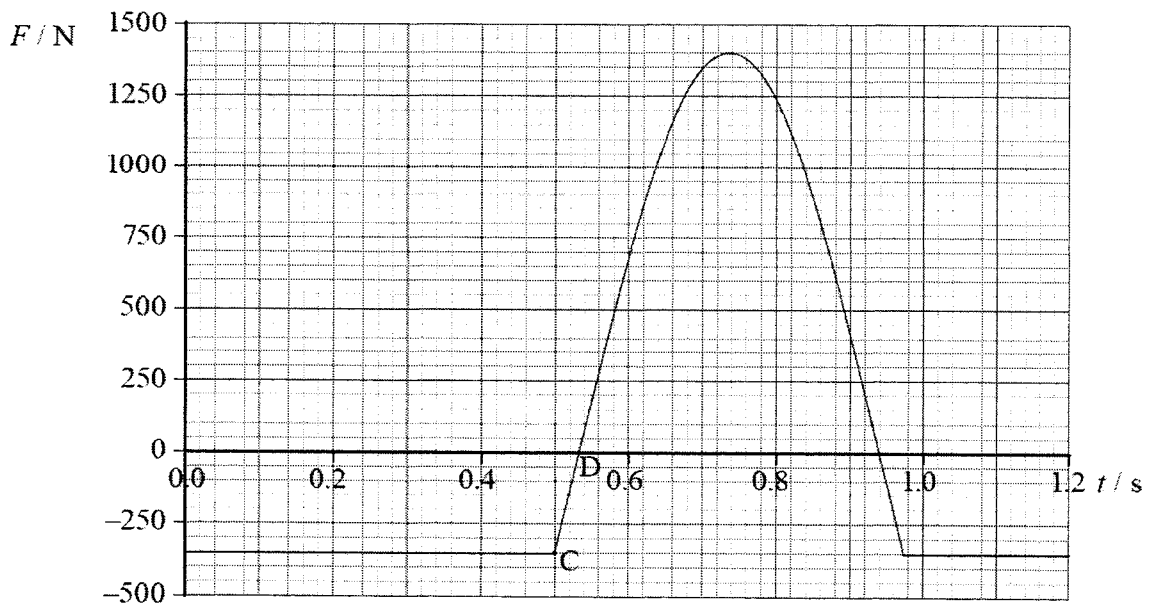

Fig. 7.3

[Turn over]

(i) The girl first makes contact with the trampoline at point C. Use data from the graph to

1. show that the mass of the girl is 36 kg. [1]

2. calculate the speed of the girl just before she lands on the trampoline.

speed of the girl just before landing = ..... m s<sup>-1</sup> [1]

3. calculate the maximum contact force on the girl when she is in contact with the trampoline.

maximum contact force = ..... N [2]

(ii) From the time between point C and point D,

1. state and explain, with reference to forces acting on the girl, how the speed of the girl is changing.

.....  
.....  
.....  
.....  
..... [3]

DO NOT WRITE IN THIS MARGIN

DO NOT WRITE IN THIS MARGIN

2. show that the change in momentum of the girl is approximately 5 Ns

[2]

3. estimate the speed of the girl at point D.

speed of the girl at D = ..... m s<sup>-1</sup> [2]

DO NOT WRITE IN THIS  
MARGIN

DO NOT WRITE IN THIS  
MARGIN

[Turn over]

8 (a) A fusion reaction between a deuterium ( ${}^2_1\text{H}$ ) nucleus and tritium ( ${}^3_1\text{H}$ ) nucleus is shown below.

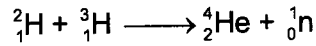

For the fusion reaction to occur the separation between the deuterium and tritium nuclei must be less than  $10^{-14}$  m. This means that the average kinetic energy of these hydrogen nuclei needs to be about 70 keV. The energy released by the fusion reaction is 18 MeV.

(i) Calculate the repulsive electrical force between the deuterium and tritium nuclei at a separation of  $10^{-14}$  m.

force = .....N [2]

(ii) Assume that a mixture of these hydrogen nuclei behaves as an ideal gas. Estimate the temperature of the mixture of nuclei required for this fusion reaction.

temperature = .....K [2]

(iii) In practice, fusion occurs at a much lower temperature. Suggest a reason why.

.....  
 .....  
 ..... [1]

DO NOT WRITE IN THIS MARGIN

DO NOT WRITE IN THIS MARGIN

(iv) Calculate the change in mass in a single fusion reaction.

change in mass = ..... kg [2]

(b) A radioisotope that decays forming another isotope is known as a parent isotope and the newly formed isotope is known as the daughter product. For a sample initially made up of pure parent isotope, Fig. 8.2 shows the variation with time  $t$  of the activity  $A$  of the parent isotope. The daughter product in this case does not decay and is described as 'stable'.

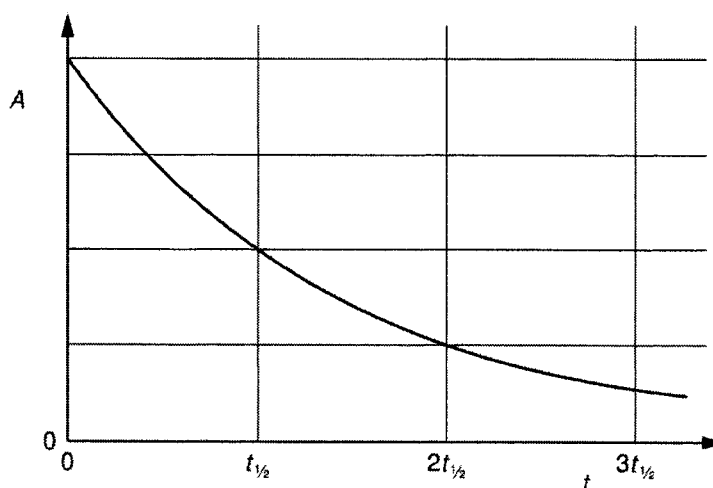

Fig. 8.2

(i) On the axes of Fig. 8.3, sketch a graph to show the variation with time  $t$  of the number  $D$  of daughter nuclei in the sample.

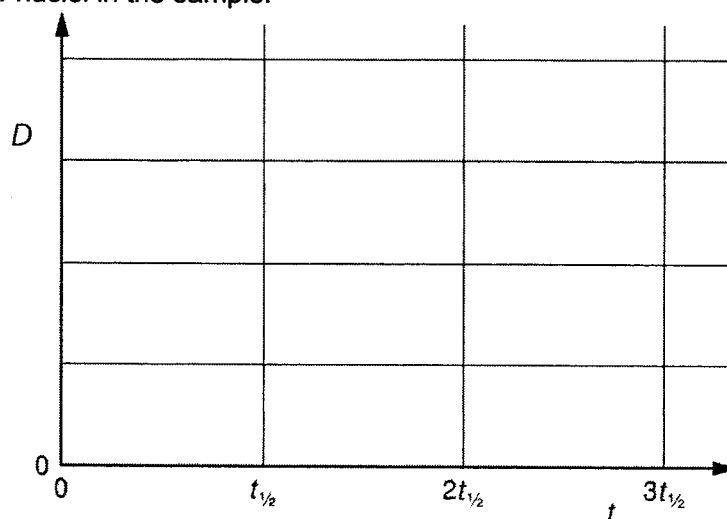

Fig. 8.3

[2]

[Turn over]

- (ii) Show that the number of daughter nuclei  $D$  after time  $t$  is given by

$$D = N_0(1 - e^{-\lambda t})$$

where  $N_0$  is the original number of parent nuclei and  $\lambda$  is the decay constant of the parent nuclei.

[1]

- (iii) The ratio of the number of parent nuclei to number of daughter nuclei can be used to calculate the age of rocks. The uranium isotope  ${}^{238}_{92}\text{U}$  is the beginning of a 'radioactive series' that ends with the stable isotope of lead,  ${}^{206}_{82}\text{Pb}$ .

The half-life of the  ${}^{238}_{92}\text{U}$  series is  $4.47 \times 10^9$  years.

1. Show that a total of eight alpha decays and six beta decays will produce  ${}^{206}_{82}\text{Pb}$  from  ${}^{238}_{92}\text{U}$ .

[2]

2. A rock is assumed to have contained no lead-206 when it was formed. In a sample of the rock, the ratio

$$\frac{\text{number of lead-206 atoms present in rock sample}}{\text{original number of uranium-238 atoms present in rock sample}}$$

is measured to be 0.39.

Calculate the time since formation of rock, assuming that all the lead-206 formed has remained in the rock.

time since formation of rock = ..... years [2]

DO NOT WRITE IN THIS MARGIN

DO NOT WRITE IN THIS MARGIN

- (iv) The same rock sample also contains uranium-235, which undergoes a series of decays to form the stable isotope lead-207.

The half-life of this  ${}_{92}^{235}\text{U}$  series is  $7.0 \times 10^8$  years. The ratio

$\frac{\text{number of lead-207 atoms present in rock sample}}{\text{number of remaining uranium-235 atoms present in rock sample}}$   
is measured to be 22.8.

1. Show that the number of daughter nuclei after time  $t$  is given by  $D = N \left( \frac{1}{e^{-\lambda t}} - 1 \right)$   
where  $N$  is the number of parent nuclei remaining at time  $t$ .

[2]

2. Use the equation for  $D$  given in (iv)1 and the data given to calculate the value for the age of the rock based on the uranium-235 decay series.

age of rock = .....years [2]

3. Rocks are often dated using three separate decay series. Suggest and explain two advantages of using three decay series to date rocks rather than just one.

.....

.....

.....

.....

.....

.....[2]

[Turn over]



**Blank Page**

DO NOT WRITE IN THIS  
MARGIN

DO NOT WRITE IN THIS  
MARGIN







**Blank Page**

DO NOT WRITE IN THIS  
MARGIN

DO NOT WRITE IN THIS  
MARGIN



[Turn over]



**Blank Page**

DO NOT WRITE IN THIS  
MARGIN

DO NOT WRITE IN THIS  
MARGIN



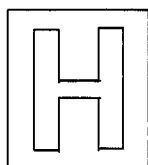

**TEMASEK JUNIOR COLLEGE**  
**2022 JC2 PRELIMINARY EXAMINATION**  
**Higher 2**



CANDIDATE  
NAME

CENTRE  
NUMBER

<b>S</b>				
----------	--	--	--	--

INDEX  
NUMBER

--	--	--	--	--

**PHYSICS**

**9749/04**

Paper 4 Practical

**31 August 2022**

**2 hour 30 minutes**

Candidates answer on the Question Paper.

Additional Materials: As listed in the Confidential Instructions

**READ THESE INSTRUCTIONS FIRST**

Write your name and C.G. in the spaces provided at the top of this page.  
 Write in dark blue or black pen on both sides of the papers.  
 You may use an HB pencil for any diagrams, graphs or rough working.  
 Do not use staples, paper clips, glue or correction fluid.  
**DO NOT WRITE IN ANY BARCODES.**

Answer all questions.

You will be allowed a maximum of one hour with the apparatus for Questions 1, and a maximum of one hour for Question 2 and 3. You are advised to spend approximately 30 minutes on Question 4.

Write down your answers in the spaces provided on the question paper.  
 The use of an approved scientific calculator is expected, where appropriate. You may lose marks if you do not show your working or if you do not use appropriate units.

Give details of the practical shift and laboratory, where appropriate, in the boxes provided.

At the end of the examination, fasten all your work securely.  
 The number of marks is given in brackets [ ] at the end of each question or part question.

<b>Shift</b>
<b>Laboratory</b>

For Examiner's Use	
1	
2	
3	
4	
<b>Total</b>	/55

This booklet consists of **20** printed pages

**[Turn over**

1 In this experiment, you will investigate the current in an electrical circuit.

- (a) (i) You have been provided with two metre rules A and B each with an electrical wire of the same resistivity is attached.

Take measurements to determine the resistance per unit length,  $r$  of the wire in A.

$$r = \dots\dots\dots [1]$$

- (ii) Measure and record the diameter,  $x$  of wire in A.

$$x = \dots\dots\dots [1]$$

- (iii) Using the values in (a)(i) and (a)(ii), determine a value for the resistivity,  $\rho$  of wire A.

$$\rho = \dots\dots\dots [1]$$

- (b) (i) Set up the circuit shown in Fig. 1.1.

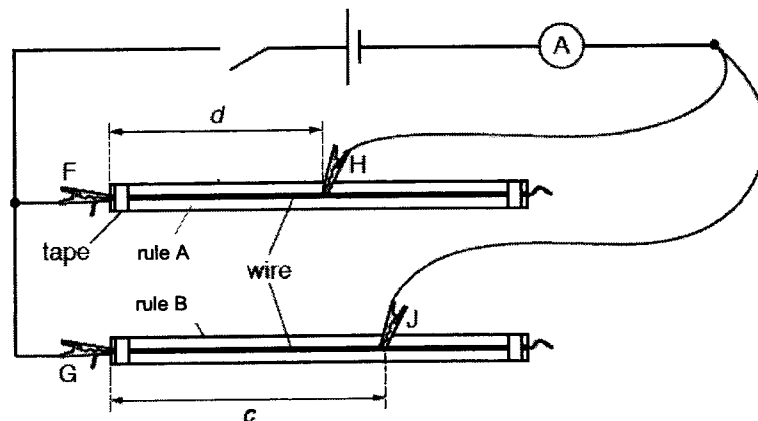

Fig. 1.1

Place H approximately half-way along the wire on rule A.

The distance between F and H is  $d$ , as shown in Fig. 1.1.

Record  $d$ .

$$d = \dots\dots\dots$$

3

Place J on the wire on rule B so that the distance between G and J is approximately 60 cm. The distance between G and J is  $c$ , as shown in Fig. 1.1.

Record  $c$ .

$c =$  .....

Calculate  $n$ , where  $n = \frac{c-d}{d}$ .

$n =$  ..... [1]

(ii) Close the switch.

Record the ammeter reading  $I$ .

$I =$  .....

Open the switch.

[Turn over

4

- (c) Keeping  $d$  constant, vary  $c$  until you have six sets of readings of  $c$  and  $l$ . Values of  $c$  should be more than  $d$ .

Record your results in a table.

[3]

- (d) It is suggested that the quantities  $l$  and  $n$  are related by the equation

$$l = S \frac{(n+2)}{(n+1)} + T$$

where  $S$  and  $T$  are constants.

- (i) Plot a suitable graph and use your graph to determine values for  $S$  and  $T$ .  
Give appropriate units for  $S$  and  $T$ .

$S =$  .....

$T =$  .....

[7]

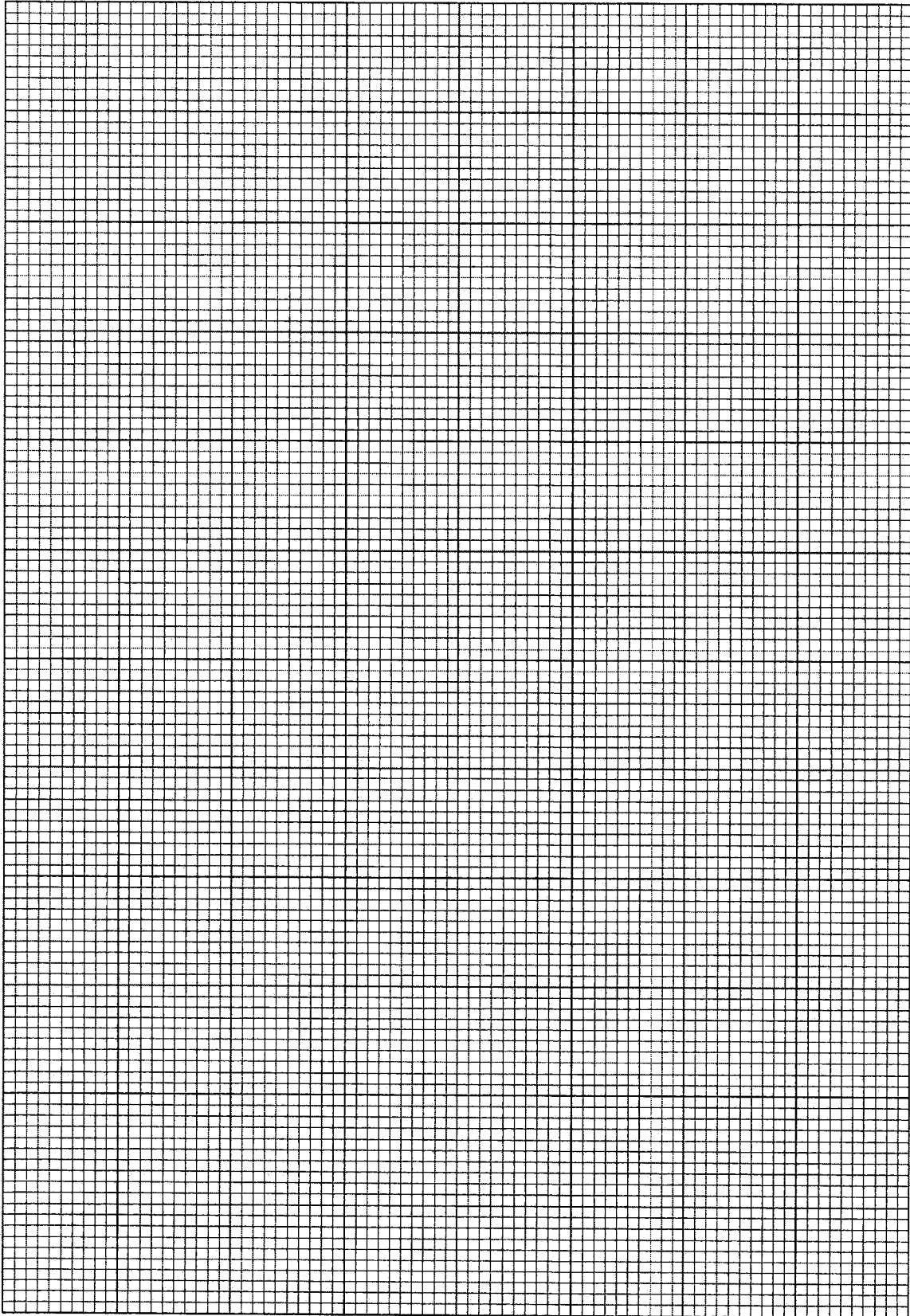

**[Turn over**

6

- (ii) Describe a method to determine the value of the current  $I$  when  $n = 0$ .

.....

.....

..... [1]

- (e) Theory suggests that  $S$  is inversely proportional to  $d$  and that  $T$  is independent of  $d$ .  
The experiment is repeated using the same equipment but a larger value of  $d$ .  
For this experiment, draw a second line on the graph to show the expected results. Label this line  $W$ .

[1]





2 In this experiment, you will investigate the motion of a metal rod.

- (a) Use the loops on one piece of string to arrange the string on a wooden rod as shown in Fig. 2.1.

The loops of the string on the wooden rod should be approximately 18 cm apart.

Repeat for the other wooden rod and string.

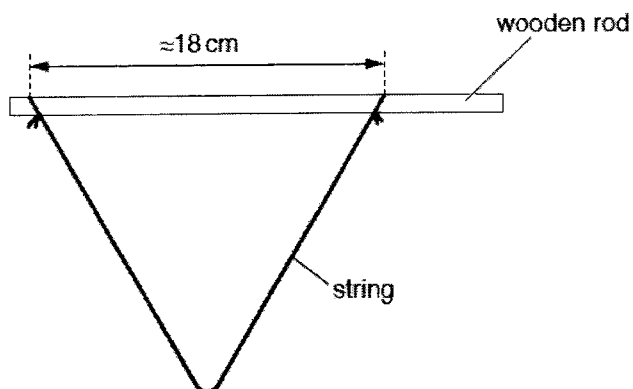

Fig. 2.1

- (b) Set up the apparatus as shown in Fig. 2.2.

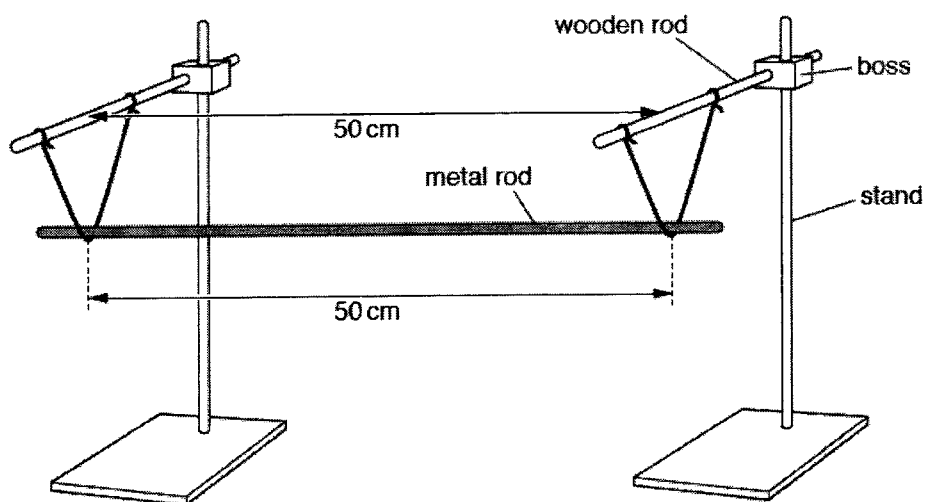

Fig. 2.2

The two wooden rods should be parallel, equal heights above the bench and 50 cm apart.

The two strings supporting the metal rod should be 50 cm apart.

9

- (i) Measure and record the angle  $\theta$  as shown in Fig. 2.3.

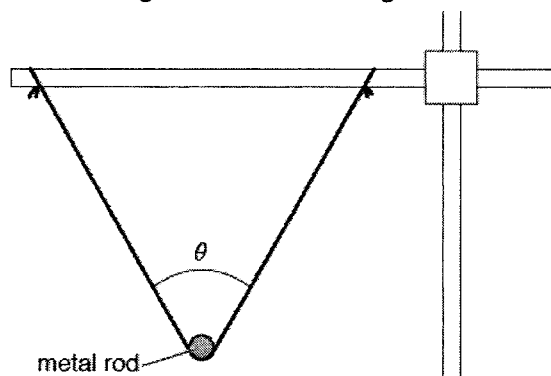

**Fig. 2.3**

$$\theta = \dots\dots\dots [1]$$

- (ii) Estimate the percentage uncertainty in your value of  $\theta$ .

$$\text{percentage uncertainty} = \dots\dots\dots [1]$$

- (iii) Calculate the value of  $\cos\left(\frac{\theta}{2}\right)$ .

$$\cos\left(\frac{\theta}{2}\right) = \dots\dots\dots [1]$$

**[Turn over**

- (c) (i) Move the metal rod to the left.  
Release the metal rod and watch the movement.  
The metal rod will move to the right and then to the left again, completing a cycle as shown in Fig. 2.4.

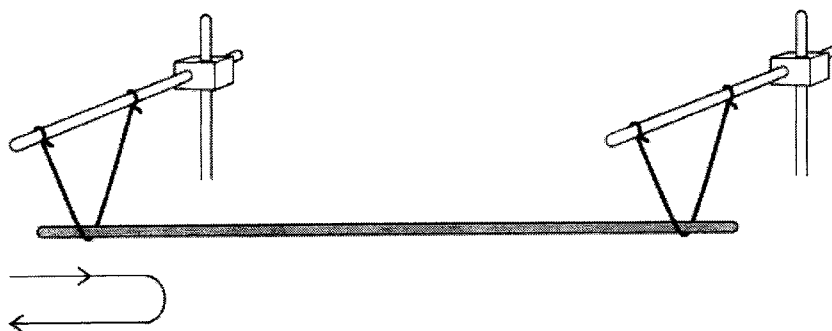

Fig. 2.4

- (ii) The time taken for one complete cycle is  $T_1$ .  
By timing several of these complete cycles, determine an accurate value for  $T_1$ .

$T_1 = \dots\dots\dots$  [2]

- (d) (i) Move the center of the metal rod towards you through a small distance.  
Release the metal rod and watch the movement.  
The metal rod will move away from you and then back towards you completing a cycle as shown in Fig. 2.5.

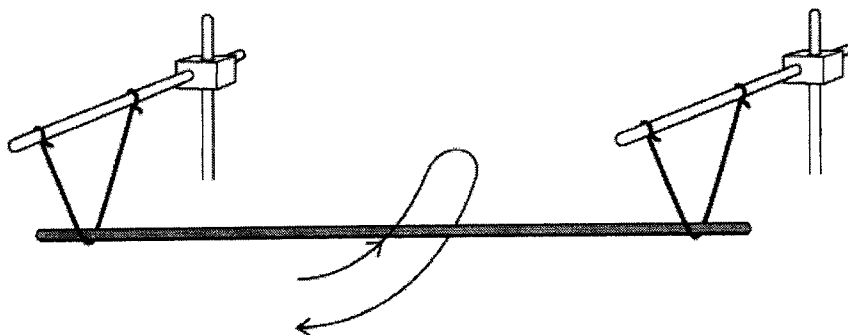

Fig. 2.5

- (ii) The time taken for one complete cycle is  $T_2$ .  
By timing several of these complete cycles, determine an accurate value for  $T_2$ .

$$T_2 = \dots\dots\dots [1]$$

- (e) (i) Reduce the distance between the loops of string on each wooden rod to approximately 9 cm as shown in Fig. 2.6.

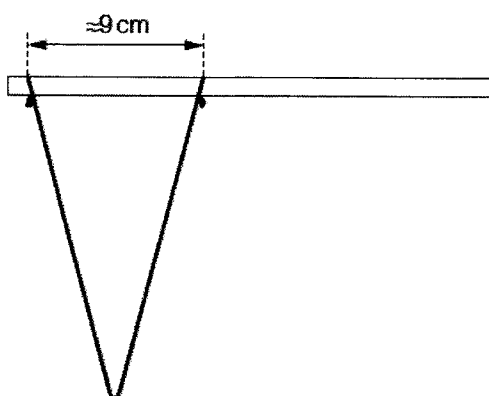

Fig. 2.6

- (ii) Repeat (b)(i), (b)(iii), (c)(i), (c)(ii), (d)(i) and (d)(ii).

$$\theta = \dots\dots\dots$$

$$\cos\left(\frac{\theta}{2}\right) = \dots\dots\dots$$

$$T_1 = \dots\dots\dots$$

$$T_2 = \dots\dots\dots$$

[3]

[Turn over

12

- (f) It is suggested that the relationship between  $T_1$ ,  $T_2$  and  $\theta$  is

$$\frac{T_1}{T_2} = k \cos\left(\frac{\theta}{2}\right).$$

where  $k$  is a constant.

- (i) Using your data, calculate two values of  $k$ .

first value of  $k$  = .....

second value of  $k$  = ..... [1]

- (ii) State whether your results in (f)(i) support the suggested relationship. Justify your conclusion by referring to your value in (b)(ii).

.....

.....

.....

.....

..... [1]

[Total: 11]

- 3 In this question, you will investigate how the attractive force between two magnets depends on their separation.
- (a) You are provided with a pair of magnets, one of which has a loop of cotton thread secured to it as shown in Fig. 3.1.

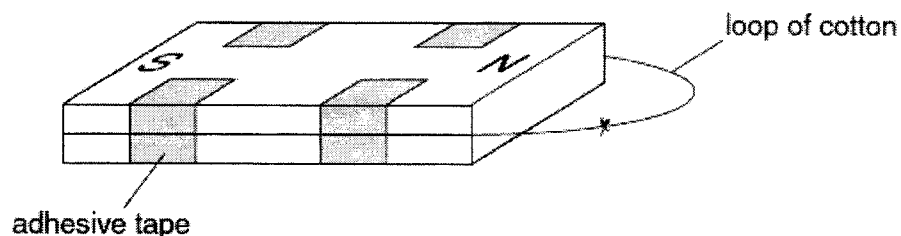

Fig. 3.1

Use sellotape to fix the other magnet to the bench.

- (i) Place the magnet with the loop of cotton end-to-end with the fixed magnet, so that they are attracting, as shown in Fig. 3.2.

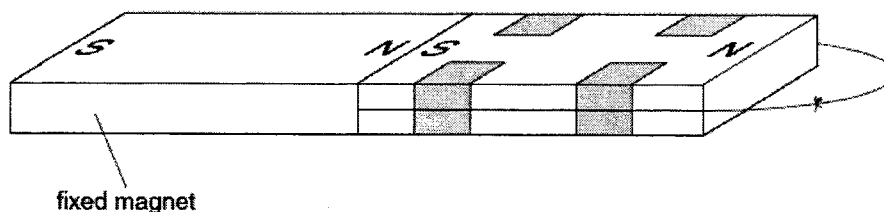

Fig. 3.2

Using the newton meter, measure the maximum force  $F$  required to pull the magnets apart, as shown in Fig. 3.3.

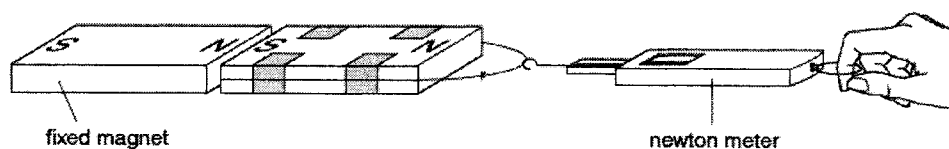

Fig. 3.3

Measure and record  $F$ .

$$F = \dots\dots\dots [1]$$

[Turn over

(ii) Explain why it is difficult to determine this force accurately.

.....  
 .....  
 ..... [1]

(iii) Estimate the percentage uncertainty in the maximum force required to separate the attracting magnets.

percentage uncertainty = ..... [1]

(b) (i) Using the micrometer screw gauge, measure the total thickness  $t$  of four of the microscope slides, as shown in Fig. 3.4.

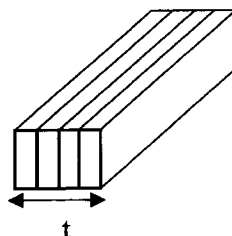

Fig. 3.4

$t =$  ..... [1]

(ii) Explain how you have made this measurement as accurate as possible.

.....  
 .....  
 ..... [1]



- (iii) Place the four slides between the two attracting magnets, as shown in Fig. 3.5. Use the newton meter to find the maximum force  $F$  needed to separate the magnets.

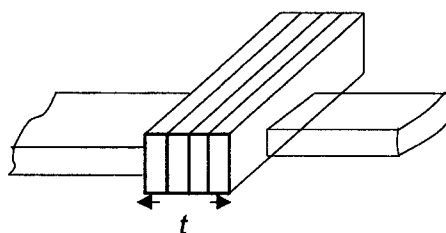

Fig. 3.5

Record  $F$ .

$F = \dots\dots\dots$  [1]

- (c) (i) Repeat (b)(i) and (b)(iii) for three slides, two slides and followed by a single slide placed between the attracting magnets. Tabulate your results below.

[2]

[Turn over

16

- (ii) It is suggested that  $F$  and  $t$  are related by the equation

$$F = \frac{p}{t} + q$$

where  $p$  and  $q$  are constants.

By plotting a suitable graph in Fig. 3.6, explain how your results support this relationship.

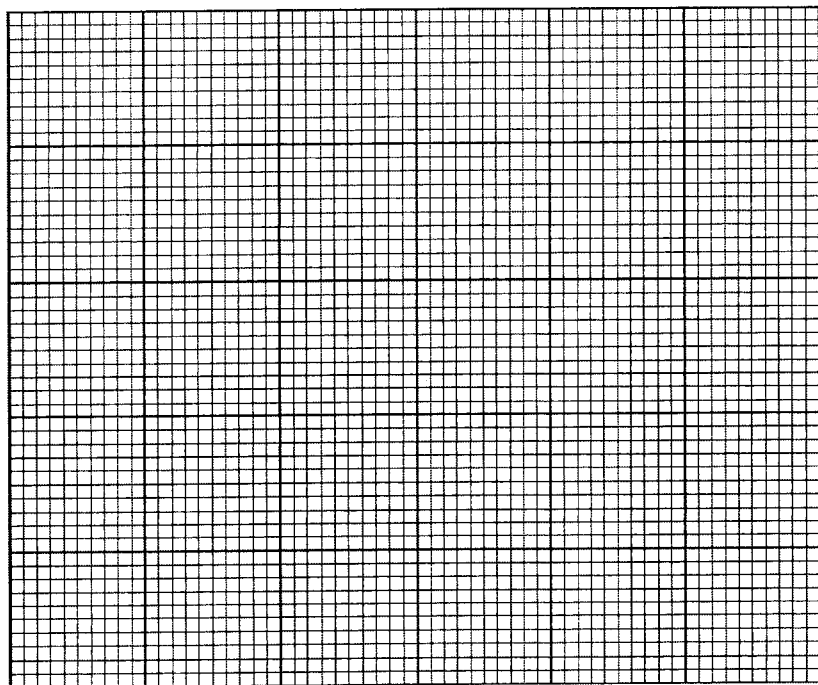
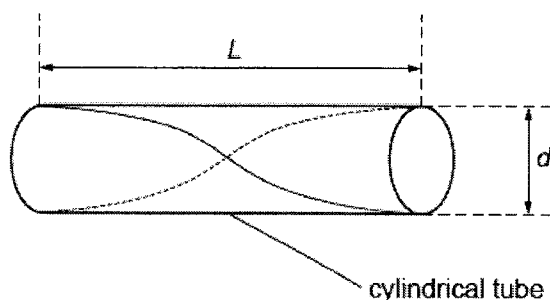

**Fig. 3.6**

.....  
.....  
..... [3]

[Total: 11]

- 4 A student investigates stationary sound waves in cylindrical tubes. Fig. 4.1 shows a stationary wave pattern in a tube which is open at both ends.



**Fig. 4.1**

The tube has length  $L$  and diameter  $d$ . The frequency of the sound for the stationary wave pattern shown is  $f$ .

It is suggested that the relationship between  $f$ ,  $L$  and  $d$  is

$$\frac{v}{f} = kL^m d^n$$

where  $v$  is the speed of sound in air and  $k$ ,  $m$  and  $n$  are constants.

There are a number of different tubes of different lengths and diameters available.

Design a laboratory experiment to test the relationship between  $f$ ,  $L$  and  $d$ .

Explain how your results could be used to determine values for  $k$  and  $v$ .

You should draw a diagram showing the arrangement of your equipment. In your account you should pay particular attention to:

- (a) the equipment you would use
- (b) the procedure to be followed
- (c) the control of variables
- (d) the analysis of the data
- (e) any precautions that should be taken to improve the accuracy and safety of the experiment.

[Turn over

**Diagram**

A series of 20 horizontal dotted lines, spaced evenly down the page, intended for drawing a diagram.



