



RAFFLES GIRLS' PRIMARY SCHOOL
SEMESTRAL ASSESSMENT 2

Name : _____ Index No: _____ Class: P3

28th October 2011

SCIENCE

Att: 1 h 15 min

Practical	20	
Section A	48	
Section B	32	
Your score out of 100 marks		
Highest score	Class	Level
Average score		
Parent's signature		

SECTION A (24 x 2 marks)

For each question from 1 to 24, four options are given.

One of them is the correct answer.

Make your choice (1, 2, 3 or 4).

Shade the correct oval (1, 2, 3 or 4) on the Optical Answer Sheet (OAS) provided.

1. Ali was given the following objects: W, X, Y and Z (NOT drawn to scale).

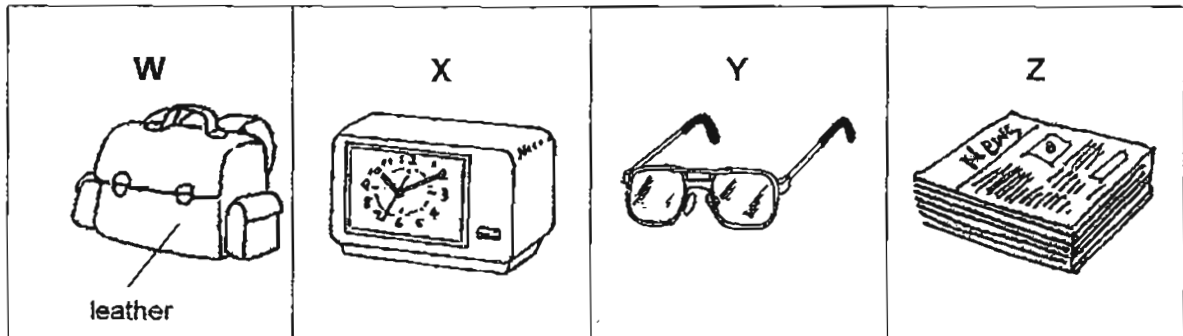

He classified the objects as follows:

objects	
group 1	group 2
W	X
Z	Y

Based on the information above, how did Ali group these objects?

- (1) according to their size
- (2) according to their shapes
- (3) according to the number of parts which each has
- (4) according to the type of material(s) they are made of

The following table gives information on four different organisms, W, X, Y and Z, based on some of their characteristics.

A tick (✓) shows that the organism has the characteristic.

characteristic \ organism	W	X	Y	Z
lives in water		✓	✓	✓
has hair on its body	✓		✓	
can make its own food		✓		
can move about on its own	✓		✓	✓

Based on the information above, answer **questions 2 and 3**.

2. Which of the following statements about W, X and Y are true?

- A X is a plant.
- B Only W is a mammal.
- C Only W does not live in water.
- D W, X and Y are aquatic organisms.

(1) A and B only

(2) A and C only

(3) B and D only

(4) A, C and D only

continued on the next page

continued from the previous page

3. In which groups do organisms X and Z belong to in the following classification diagram?

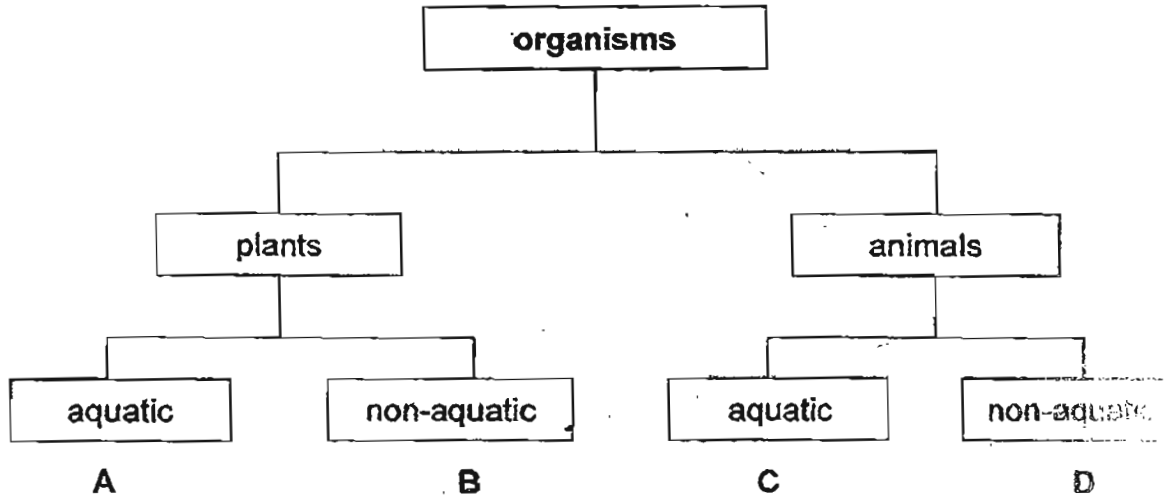

	organism X	organism Z
(1)	A	B
(2)	A	C
(3)	B	C
(4)	B	D

4. The picture below shows a fish with some of its parts labelled B, C and D.

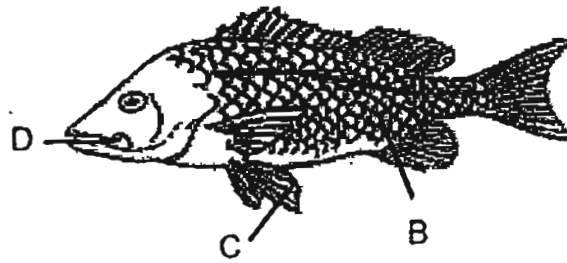

Which one of the following identifies the function of each part correctly?

	B	C	D
(1)	to keep itself warm	to protect itself from injury	to take in food
(2)	to take in air from water	to balance itself in water	to protect itself from injury
(3)	to protect itself from injury	to balance itself in water	to take in food and air
(4)	to balance itself in water	to protect itself from injury	to take in air and water

5. The diagrams below show different types of animals with one of its parts labelled : W, X and Y.

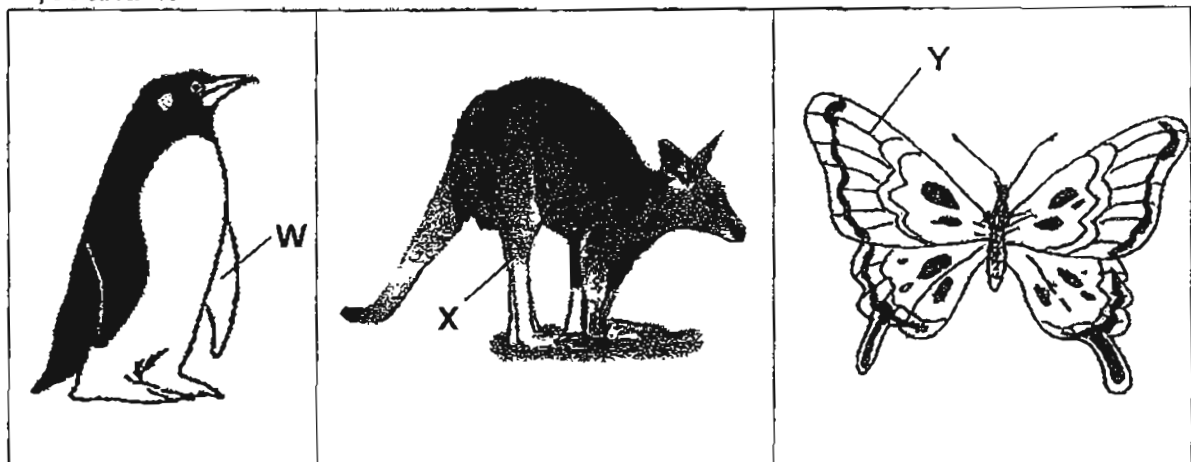

How does each of these parts enable the animals to move?

	W	X	Y
(1)	to fly	to run	to glide
(2)	to swim	to hop	to fly
(3)	to swim	to walk	to fly
(4)	to glide	to crawl	to soar

6. Jia Yi was given the following animals:

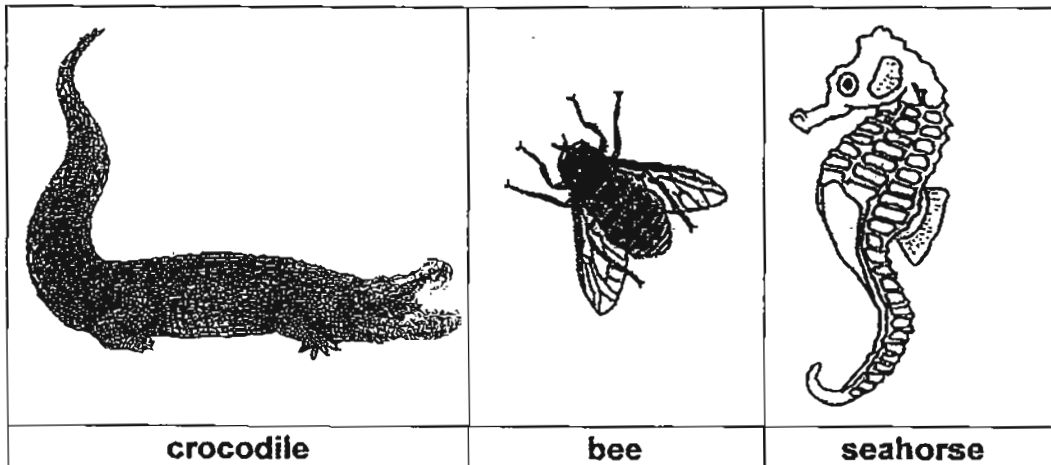

She wanted to use the flow chart below to classify them.

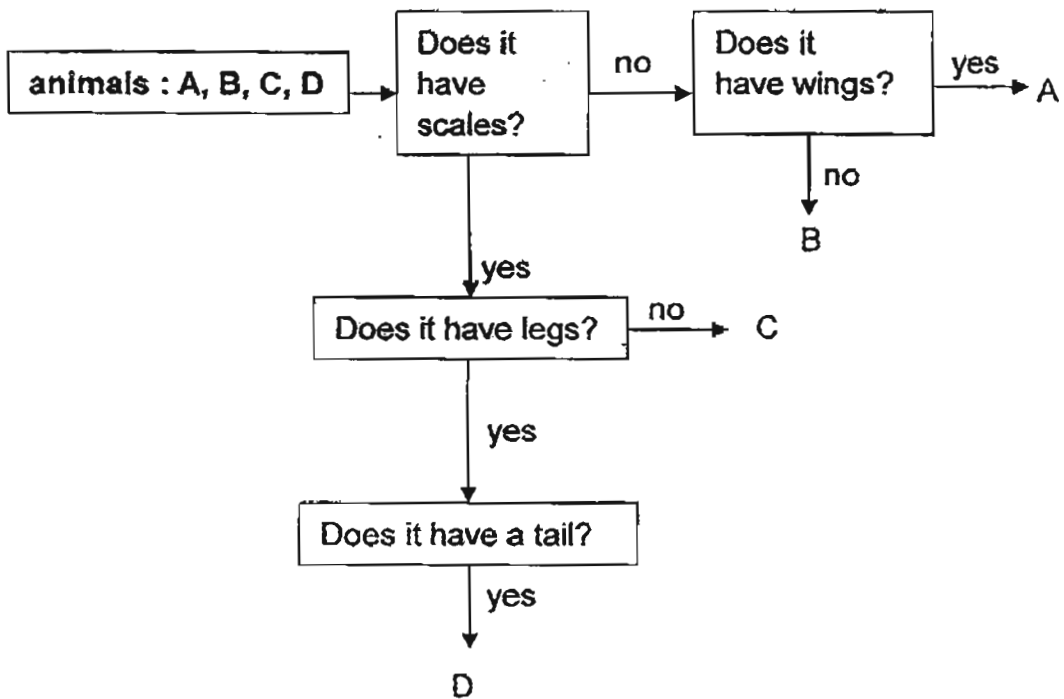

Using the flow chart, which one of the following identifies these animals correctly?

	crocodile	bee	seahorse
(1)	A	B	D
(2)	B	C	A
(3)	C	A	D
(4)	D	A	C

7. Which one of the following statements about plants is **NOT** true?

- (1) Non-flowering plants do not bear fruits.
- (2) Plants need air, water and food to grow.
- (3) Flowering plants bear flowers all the time.
- (4) Ferns are non-flowering plants which reproduce from spores.

8. Some pupils came across three different types of plants, X, Y and Z, as shown in the diagrams below.

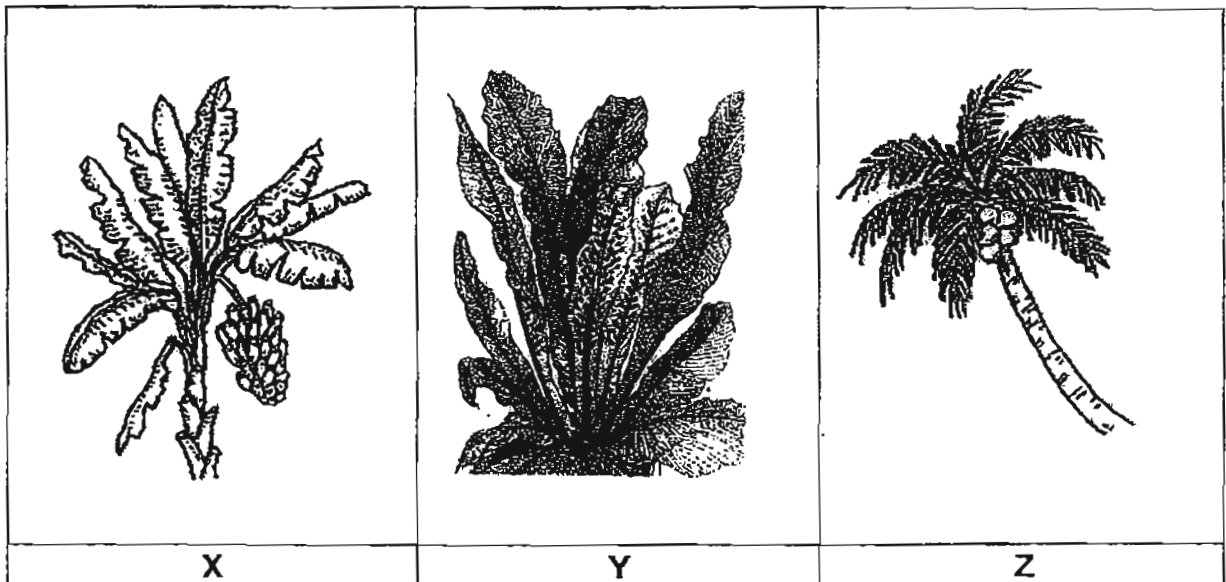

The pupils made the following statements about these plants:

- A Z is a flowering plant since it bears fruits.
- B Y is a non-flowering plant because it reproduces by spores.
- C X, Y and Z are non-flowering plants as they do not bear flowers.
- D Both X and Y are non-flowering plants as they do not bear fruits.

Which of these statement(s) is/ are correct?

- (1) A only
- (2) C only
- (3) A and B only
- (4) B and D only

9. Which of the following cannot be seen with our naked eyes?

- A ferns
- B fungi
- C yeast
- D mosses
- E bacteria

- (1) A and B only
- (2) C and E only
- (3) A, B and D only
- (4) C, D and E only

10. Which of the following are correct examples of cycles?

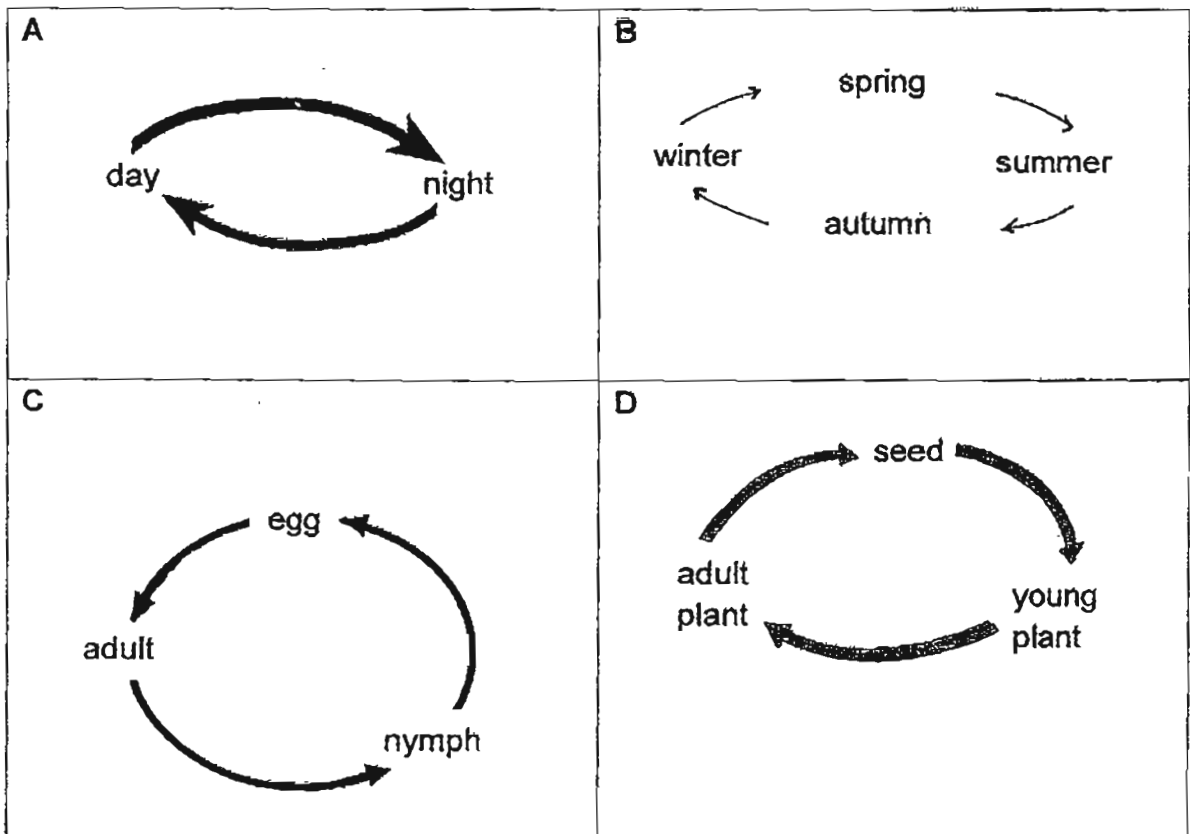

- (1) A and B only
- (2) C and D only
- (3) A, B and D only
- (4) A, C and D only

11. The diagram below shows the life cycle of an animal P.

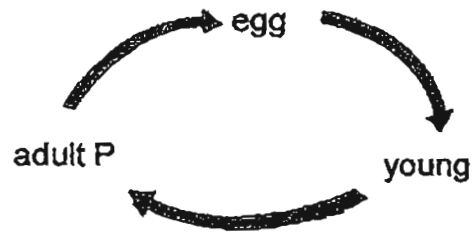

Which of the following animals has/ have the same number of stages in its life cycle/ their life cycles as animal P?

- A frog
- B chicken
- C butterfly
- D mosquito

- (1) A only
- (2) A and B only
- (3) C and D only
- (4) B, C and D only

12. The young of insects will replace their body coverings with new ones as they grow in size. This process is known _____.

- (1) hatching
- (2) moulting
- (3) fertilisation
- (4) reproduction

13. Shermaine recorded the stages of growth of a germinated seed as follows:

- A The root appeared.
- B The shoot appeared.
- C The seed took in water.
- D The first leaves appeared.
- E The seed coat dropped off.

Which one of the following shows the correct sequence of growth of the germinated seed?

	1 st stage				
(1)	C	B	A	D	E
(2)	C	E	A	B	D
(3)	E	C	A	B	D
(4)	E	C	B	A	D

14. Madam Siti grew two different types of plants as shown below.

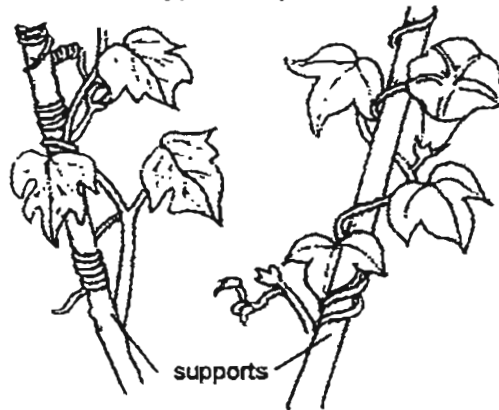

Why did Madam Siti place supports for both plants to cling onto?

- A The plants had weak stems.
- B The plants could get more air.
- C The plants could take in more water.
- D The plants could receive more light to make food.

(1) A only

(2) A and C only

(3) A and D only

(4) B and D only

15. Divya placed a plant in a black box with a small hole at one of its sides. She put the box in an open space and watered the plant in it everyday.

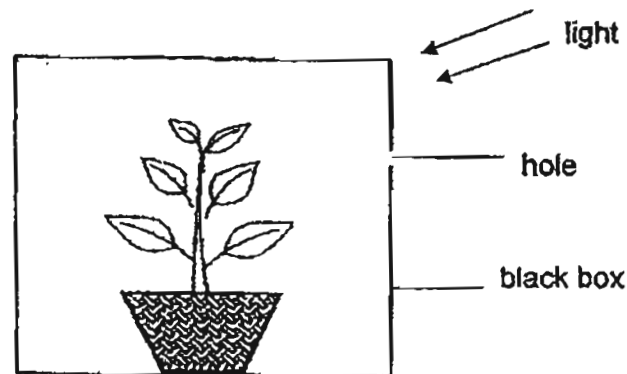

After a few days, Divya observed that the plant grew towards the hole.

What was Divya trying to find out from her experiment?

- (1) To find out if the plant responded to light
- (2) To find out if the plant needed air to grow
- (3) To find out if the plant grew better in a black box
- (4) To find out if the plant needed water to stay alive

16. The table below describes the property/ properties of 3 similar cups, X, Y and Z, each made of a different material.

A tick (✓) in the box indicates the presence of such a property.

property of material	X	Y	Z
breaks into pieces when dropped	✓		✓
it allows the object in it to be seen			✓
can be scratched with a plastic ruler		✓	

Which one of the following identifies the materials of these cups correctly?

	X	Y	Z
(1)	metal	paper	clear plastics
(2)	ceramic	metal	clear glass
(3)	ceramic	paper	clear glass
(4)	clear glass	paper	ceramic

17. The diagram below shows the labelled part, A, of a bicycle.

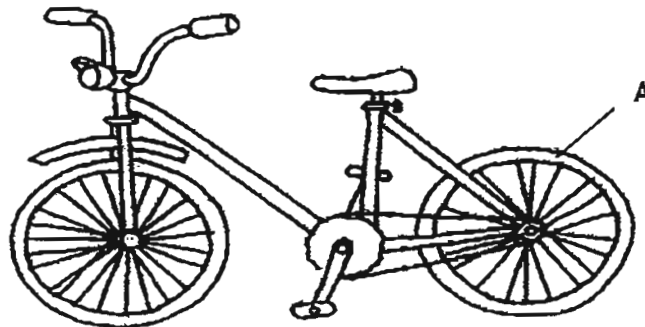

What is part A made of and the reason for the use of such a material?

	material	reason
(1)	metal	It is strong.
(2)	wood	It is hard.
(3)	rubber	It is stretchable.
(4)	plastics	It can support a heavy body.

18. Part X of the car shown below is made of glass.

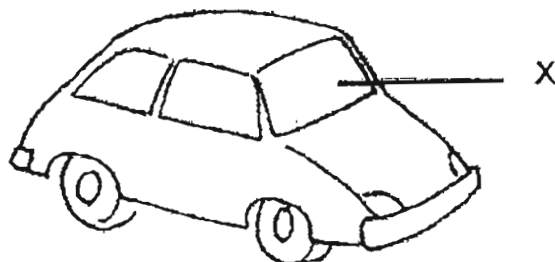

Why is glass commonly used to make part X of the car?

- A We can see through glass.
- B We can break glass easily.
- C Glass is a non-magnetic material.
- D Glass does not allow water to pass through.

- (1) A and B only
- (2) A and D only
- (3) B and D only
- (4) C and D only

19. Three pupils, Ashley, Ben and Charis, observed that magnet A “floated” above magnet B as shown below.

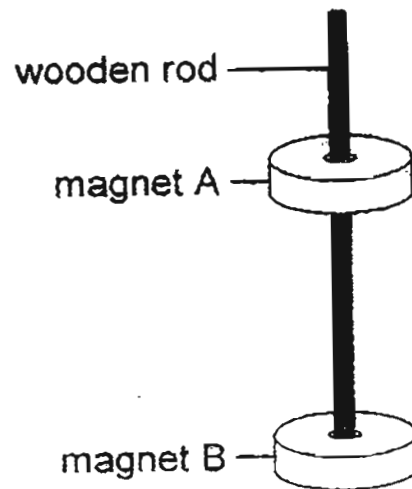

The pupils made the following conclusions:

Ashley : Magnet A lost its magnetism.

Ben : Like poles of magnets A and B were facing each other.

Charis : Unlike poles of magnets A and B caused them to push each other apart.

Which of these pupils made the correct statement(s)?

- (1) Ben only
- (2) Charis only
- (3) Ashley and Charis only
- (4) Ashley, Ben and Charis

20. Janelle clamped a bar magnet to a retort stand. She brought a metal clip, held to the table top by a string, near the bar magnet. The metal clip remained in the air as shown below.

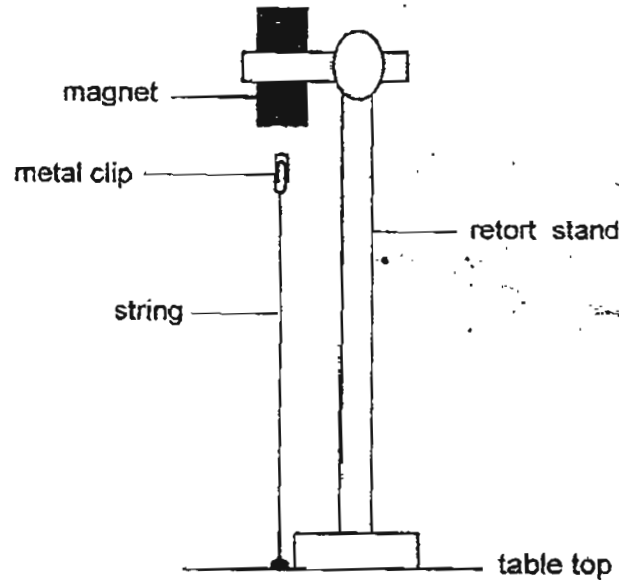

Which one of the following explains why the metal clip did not drop to the table top?

- (1) The magnet attracted the metal clip.
- (2) The string held the metal clip upright.
- (3) The magnet repelled the metal paper clip.
- (4) The metal clip was not heavy enough to drop to the table.

21. Two bar magnets, suspended by strings, were separated by a thin metal piece.

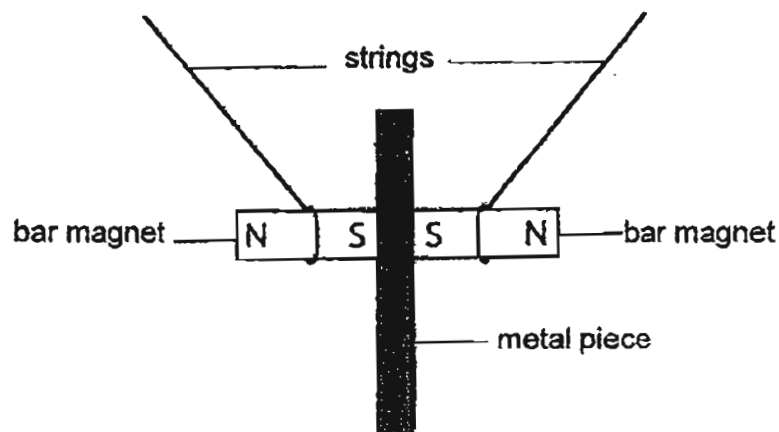

Which one of the following statements best explains the behaviour of these bar magnets?

- (1) The metal piece attracted the magnets.
- (2) The magnets lost their magnetic strength.
- (3) Magnetism could not pass through the metal piece.
- (4) Like poles of these bar magnets attracted each other.

22. A mixture of magnetic and non-magnetic materials found in sand is separated using the machine as shown below.

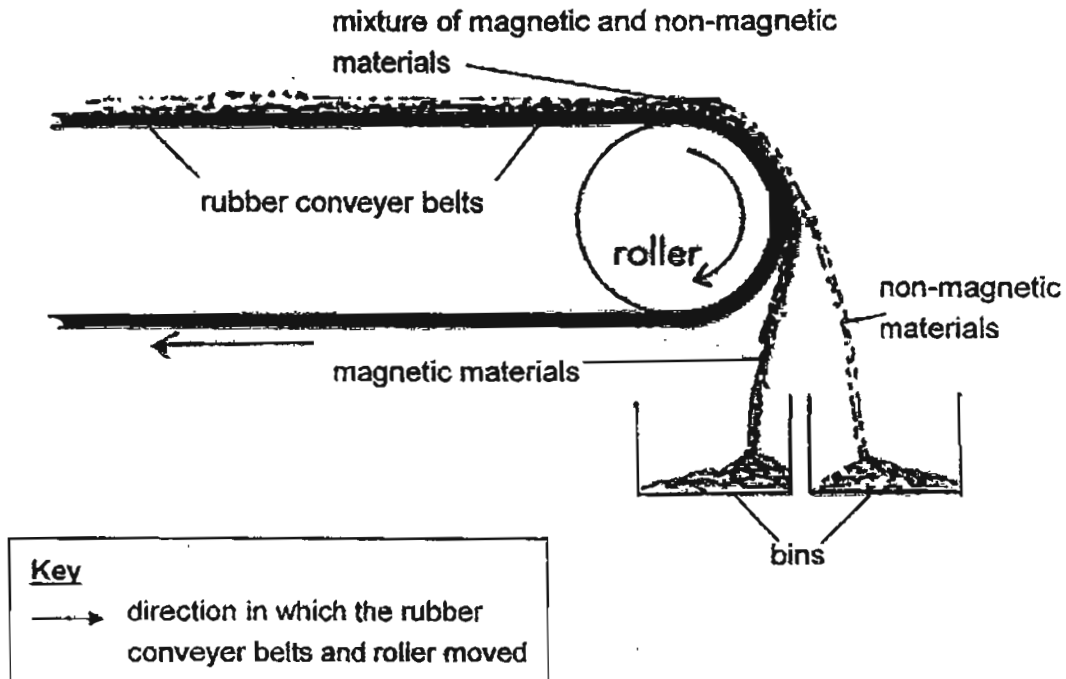

Based on the information above, which of these statements are true?

- A Magnetic force can pass through rubber.
 - B Magnetic materials are attracted to the roller.
 - C Non-magnetic materials cannot be attracted to the roller.
- (1) A and B only (2) A and C only
- (3) B and C only (4) A, B and C

23. An iron bar AB was magnetised using the "stroking" method as shown below.

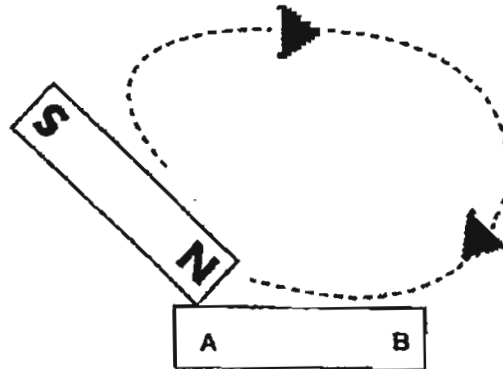

Which one of the following statements about the magnetised iron bar AB is incorrect?

- (1) AB has a North and South pole.
 - (2) AB is not able to attract a pin made of iron.
 - (3) AB will lose its magnetism when dropped many times.
 - (4) AB will come to rest in the North-South direction when it is freely suspended.
24. Deene conducted an experiment as shown below.

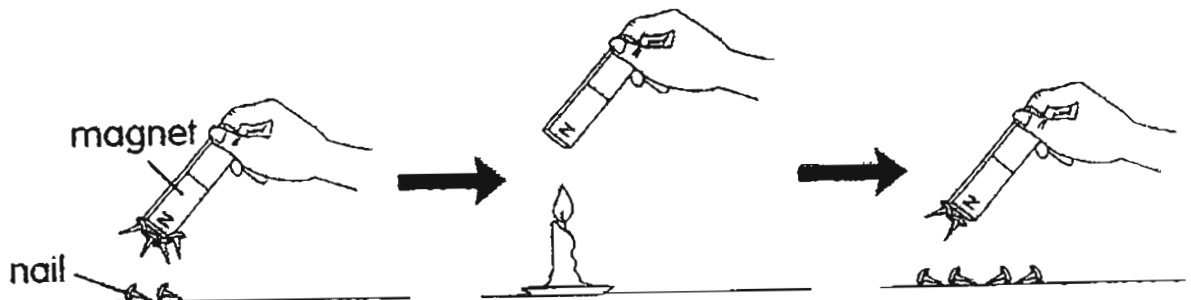

What could Deene conclude from her experiment?

- (1) A magnet had to be heated before use.
- (2) A magnet became stronger when heated.
- (3) A magnet lost its magnetism when heated.
- (4) Heating the magnet did not change its magnetic strength.

Marks

32

Name : _____ Index No: _____ Class: Primary 3 _____

SECTION B (32 marks)

For questions 25 to 38, write your answers clearly in the spaces provided.

The number of marks available is shown in the brackets [] at the end of each question or part question.

25. The table below shows the recorded length of a fish in a pond at the end of each week during a period of time.

end of week	1	2	3	4	5	6
length of fish (cm)	2	6	11	15	15	15

Based on the information above, answer the following questions :

- (a) Describe the change~~s~~ in the fish from weeks 1 to 4. [1]

- (b) What could be concluded about the length of the fish from week 4 onwards? [1]

26. Four similar-sized lizards of the same type were each placed in identical containers in the set-ups as shown below.

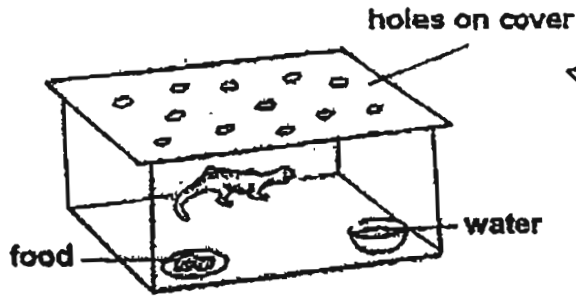

set-up A

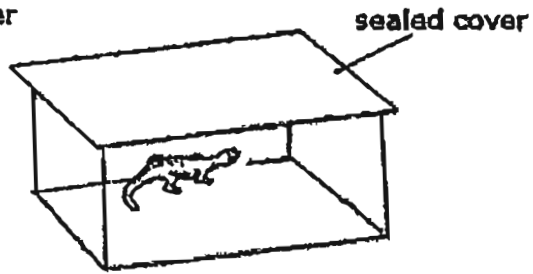

set-up B

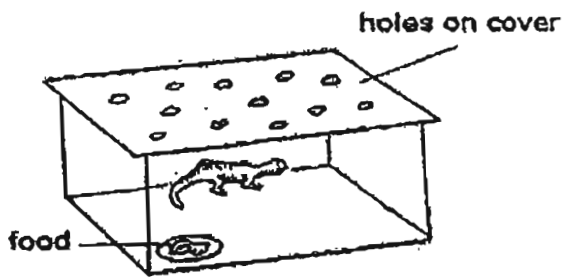

set-up C

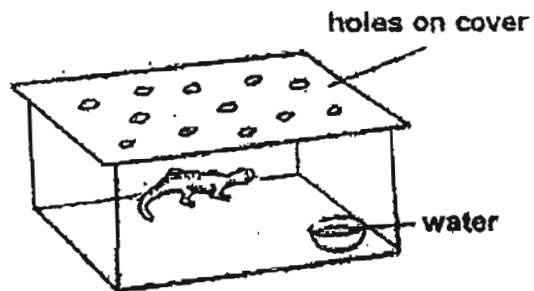

set-up D

continued on the next page

continued from the previous page

Based on the information on page 20, answer the following questions:

(a) Which one of these lizards would die first?

Name the set-up, A, B, C or D.

Explain your answer.

[1]

lizard in set-up	explanation

(b) State the characteristics of living things demonstrated in this experiment.

[1]

27. Below are pictures of animals X and Y.

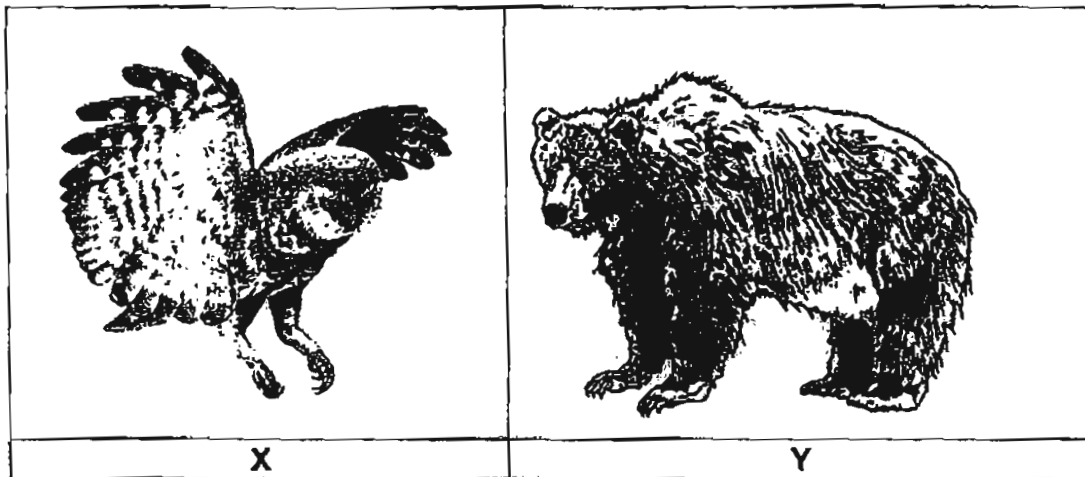

(a) Give one function of the body coverings of these animals. [1]

Based on your **observations** of these animals, compare animals X and Y.

(b) State each of the following in the table below.
(Do **NOT** compare their shape and size, and do **NOT** state what each animal is.) [2]

ONE SIMILARITY between X and Y	
ONE DIFFERENCE between X and Y	

28. Below are pictures of two different types of organisms, X and Y.

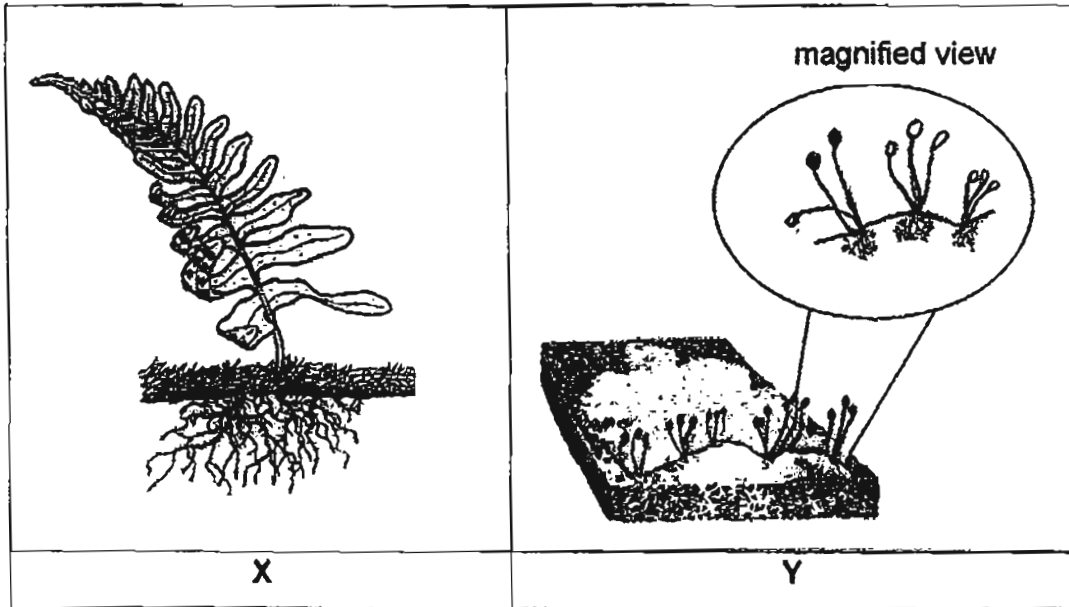

Based on your **observations** of these organisms, answer the following questions :

- (a) These organisms, X and Y, can be classified as shown below.
Write the **group of living things** which X and Y belong to in (i) and (ii).
[1]

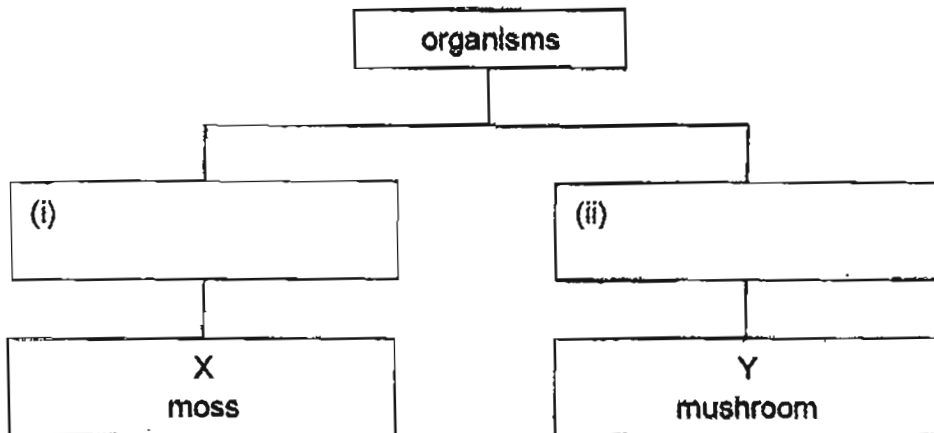

- (b) How do X and Y reproduce? [1]
-

29. In a pond, some plants, P, Q, R and S, were found growing as shown in the diagram below :

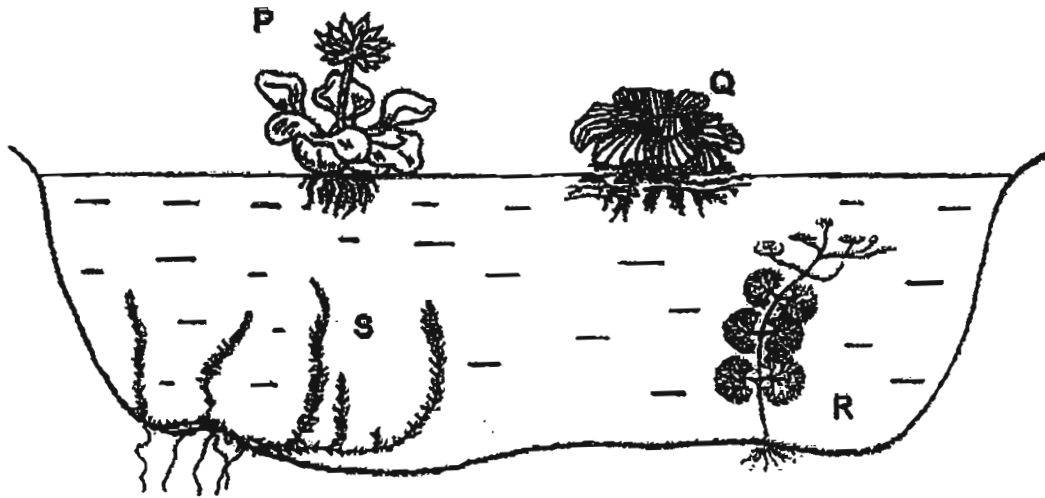

Based on the diagram above, answer the following questions :

- (a) Classify these plants using the classification diagram below. Write letters P, Q, R and S **ONCE** only. [2]

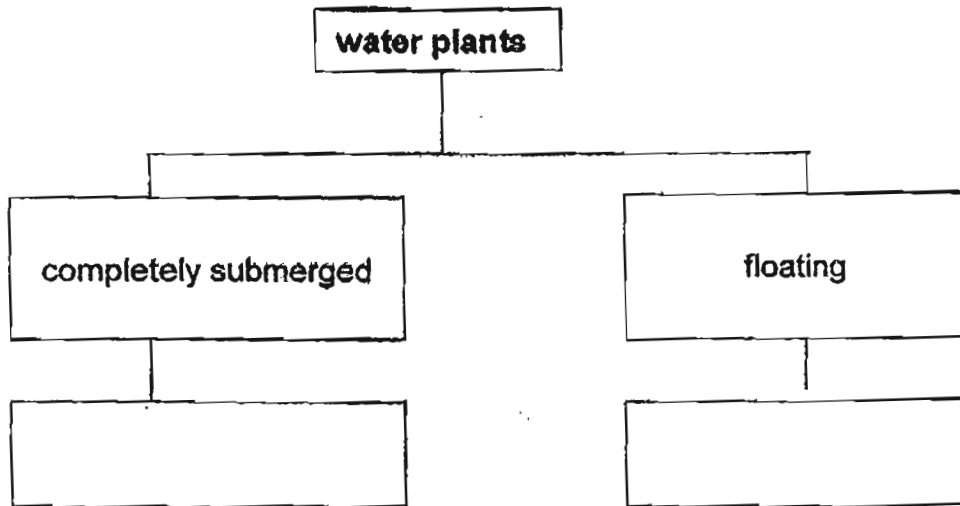

- (b) When the number of plants, P and Q, increased quickly and covered the surface of the pond completely, plants R and S could not survive. What was the reason for this? [1]

30. The diagrams below show the life cycles of two types of organisms : Y and Z.

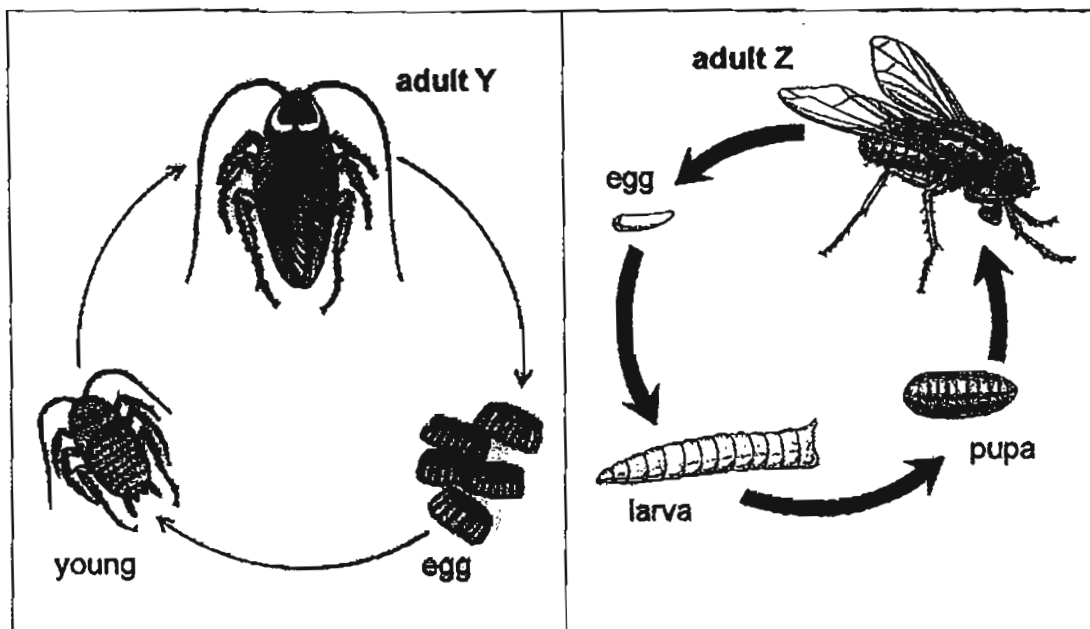

Based on your **observations** of the diagrams above, compare the life cycles of organisms Y and Z.

State two differences between the life cycles of Y and Z.
 (Do **NOT** compare the physical characteristics of the two organisms.) [2]

DIFFERENCE 1	
DIFFERENCE 2	

31. The diagram below shows the duration of each stage in the life cycle of an organism.

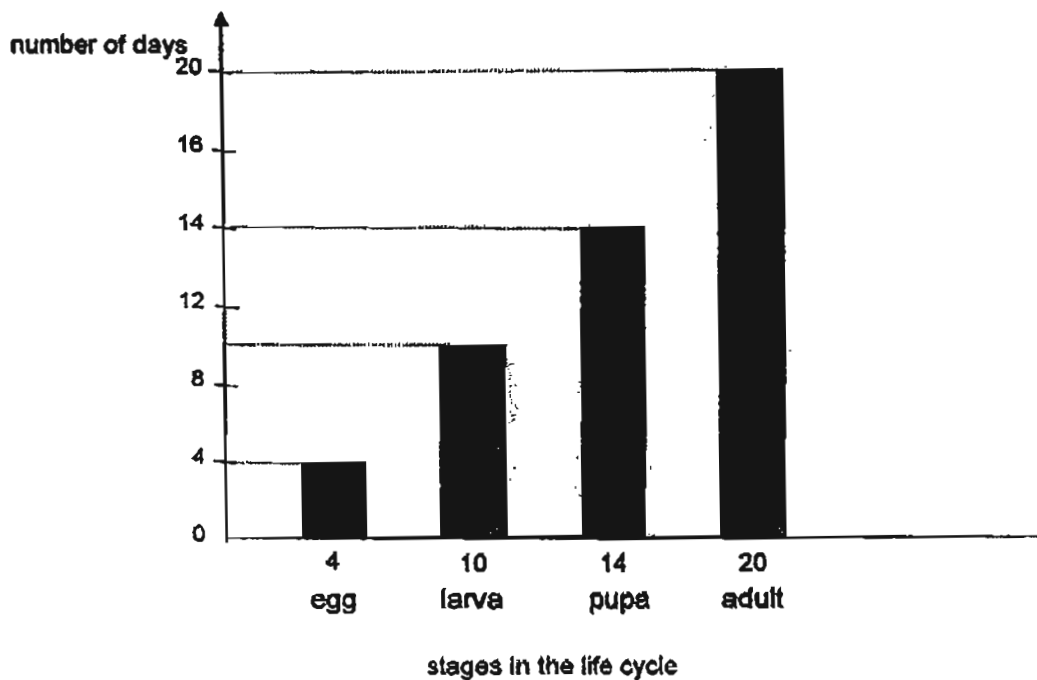

Based on the diagram above, answer the following questions:

- (a) Name the stage which lasts for the shortest time. [1]

- (b) Name the stage of the organism on the 20th day after the egg has hatched. [1]

32. The diagram below shows an incomplete life cycle of a flowering plant.

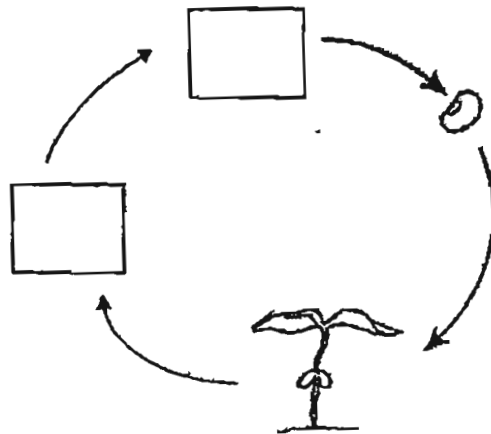

(a) Complete the diagram above using the pictures below.

In the boxes above, write letters A, B and / or C ONCE.

[1]

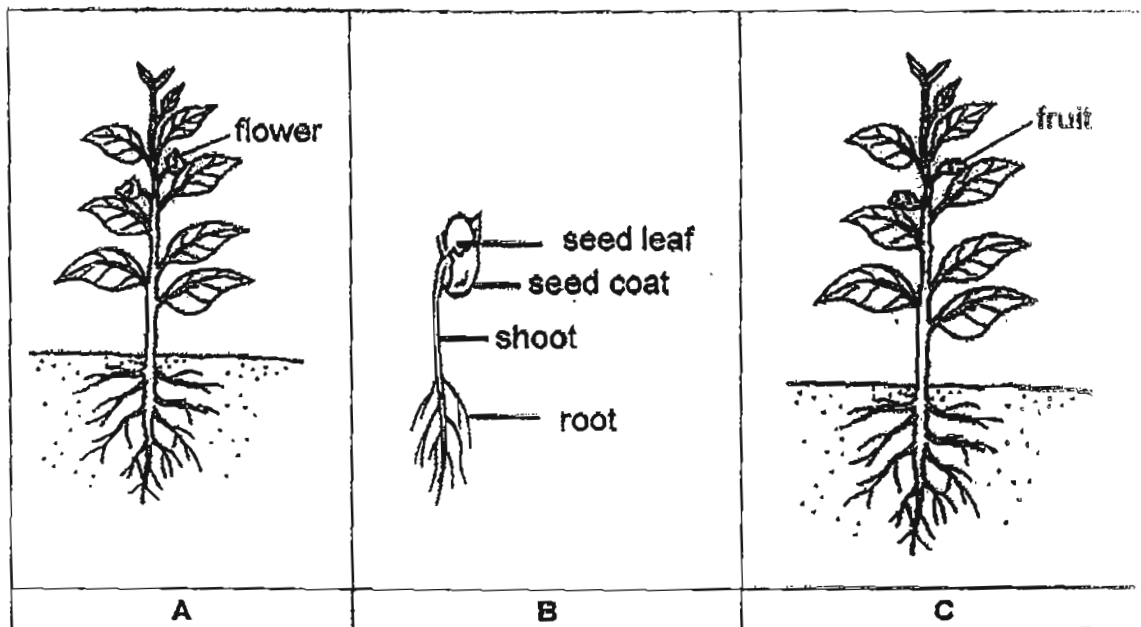

(b) Which part of the seedling will eventually drop off?

Name the part and state one of its functions.

[1]

part of the seedling	function

33. Alex carried out an experiment using two identical pots with an equal number of seedlings. One pot was placed under light while the other pot was kept in a black box with a small hole at one of its sides.

Alex measured and recorded the average heights of the seedlings over 15 days.

day	average height of seedlings (mm)	
	in pot under light	in pot in a box
3	4	5
6	6	8
9	14	20
12	23	32
15	42	52

Based on the information above, answer the following questions:

- (a) Compare the average height of the seedlings in the two pots. State one difference in Alex's observations of the seedlings. [1]

continued on the next page

continued from the previous page

In **ANOTHER** experiment, Alex placed a pot of seedlings in a clear glass box with a small hole at one of its sides. He predicted that the seedlings would grow towards the hole in the box as shown below.

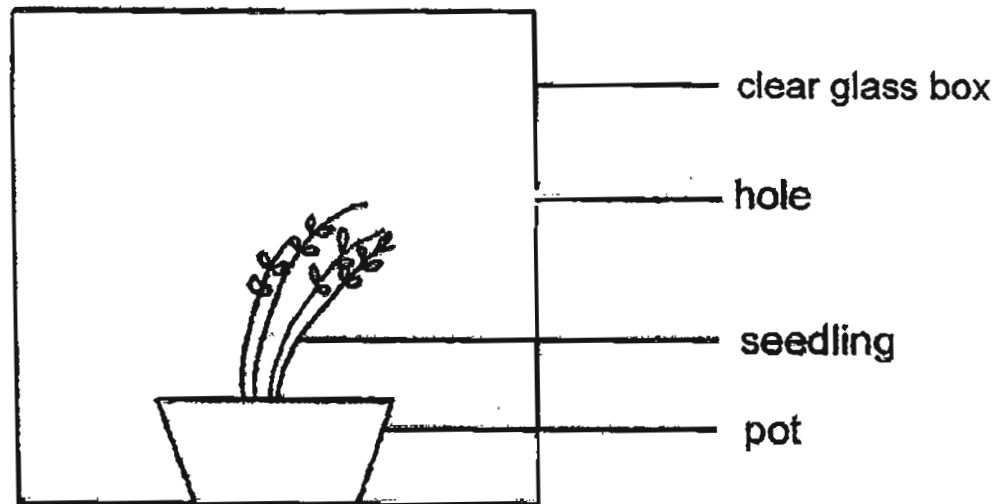

(b) Was Alex correct in his prediction? Explain your answer. [1]

34. The diagram below shows a nutcracker that is used to crack a nut.

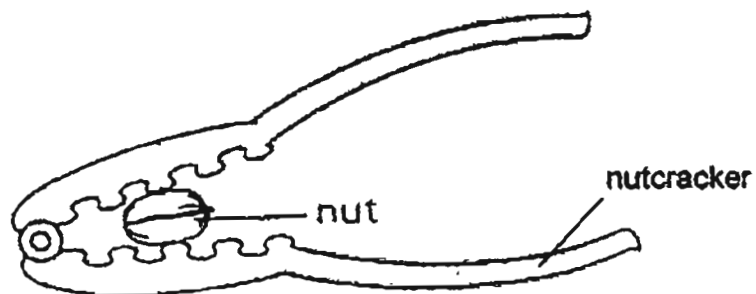

The nutcracker is made of stainless steel.

Give two reasons why it is made of stainless steel.

[2]

REASON 1	
REASON 2	

35. There are four solid balls of equal size, each made of a different material. They were dropped from the same height into a plastic container of water.

The diagram below shows the position of each ball in a container of water.

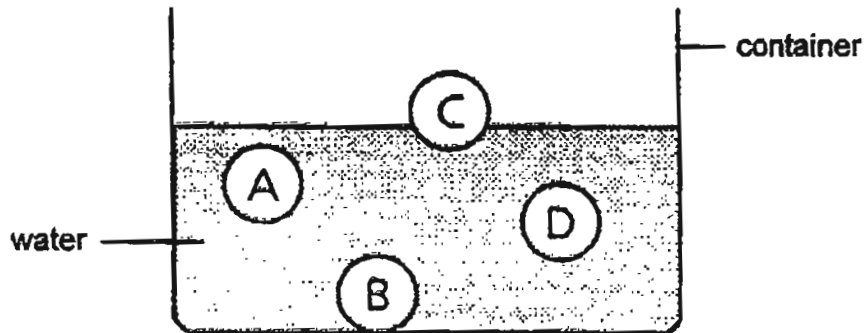

None of the balls was made of wood.

- (a) Suggest a material for ball B.

[1]

continued on the next page

continued from the previous page

Megan filled four bags, P, Q, R and S, with balls B, one at a time. The bags were of equal size and each made of a different material.

The bar graph below shows the maximum number of balls B that each bag could hold just before it broke.

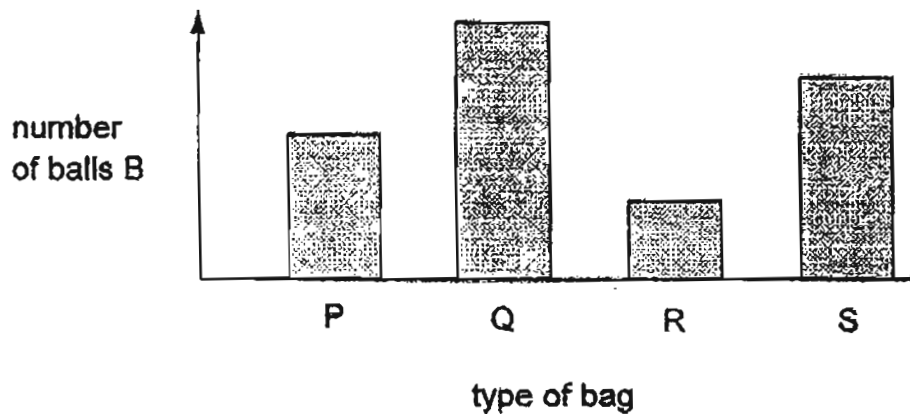

Based on the information above, answer the following questions :

(b) Which one of these bags is best used as a school bag?

Write letter P, Q, R or S only.

Explain your answer.

[1]

bag	explanation

36. Meiling tied a strong bar magnet and an object A to two identical toy cars, X and Y, respectively. She moved toy car X towards toy car Y in the direction of the arrow as shown below.

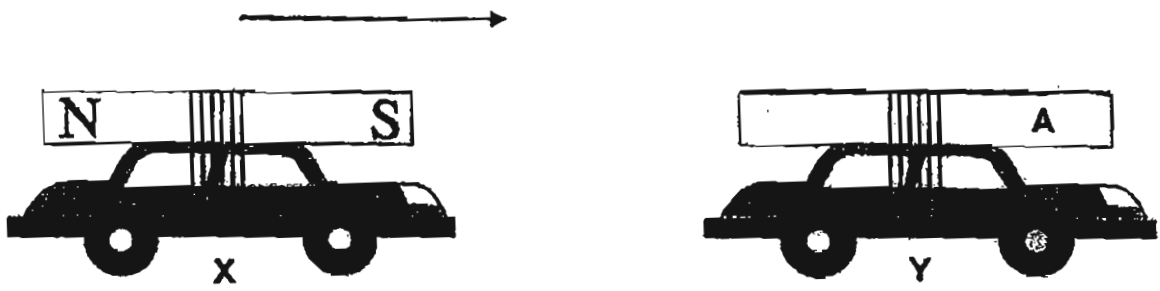

Meiling observed that toy car Y moved away from toy car X.

Next, Meiling replaced object A with similar objects B, C and D, **ONE** at a time, and recorded her observations as follows:

object	A	B	C	D
observation	car Y moved away	car Y did not move at all	car Y moved towards car X	car Y did not move at all

Based on the information above, answer the following questions:

- (a) Which one of these objects, A, B, C or D, was definitely a magnet?
Give a reason for your answer. [1]

- (b) Other than the object mentioned in (a), which of these objects, A, B, C and / or D, was / were magnetic?
Give a reason for your answer. [1]

37. Nicole used 4 rods, A, B, C and D, of the same length and thickness, each made of a different material. She coiled an equal number of turns round each rod using the same type of wire. Next, she connected coiled rod A to a battery in a circuit and observed the number of pins it attracted.

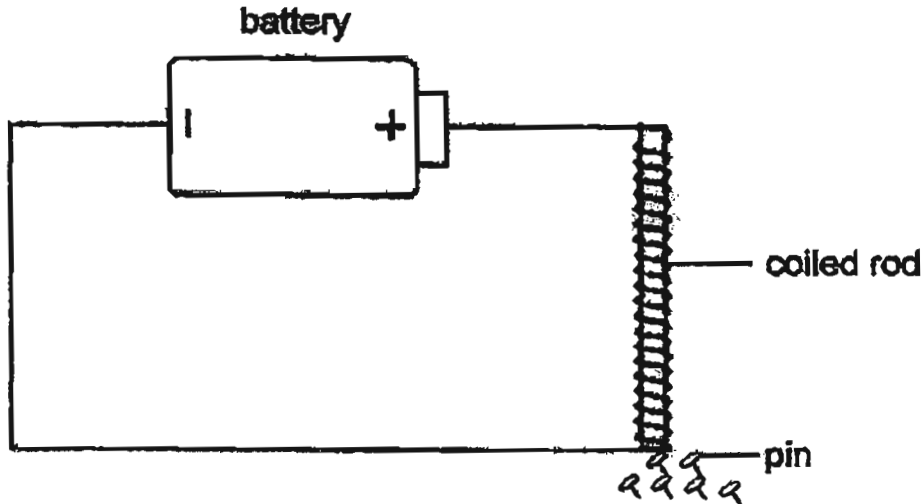

Nicole replaced coiled rod A with coiled rods B, C and D, ONE at a time, and recorded her results in the table as shown below.

coiled rod	A	B	C	D
number of pins the rod attracted	20	13	0	5

Based on the information above, answer the following questions:

- (a) Write letter A, B, C and / or D in each blank. [2]
- (i) Rod(s) _____ was / were most likely made of plastics.
- (ii) Rod _____ was the strongest electromagnet.
- (b) State two ways in which Nicole could make the electromagnet(s) stronger. [2]

1 st WAY	
2 nd WAY	

38. Jerlynn made a fishing rod with a ring magnet at one end. She used her fishing rod to fish out the cut-outs from the ~~tank~~ ^{tank} glass ~~as~~ ^{as} shown below.

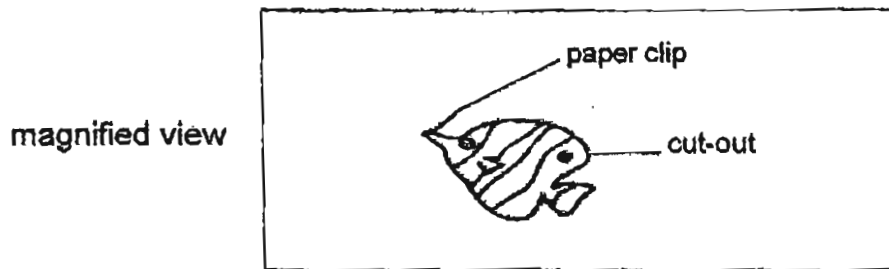
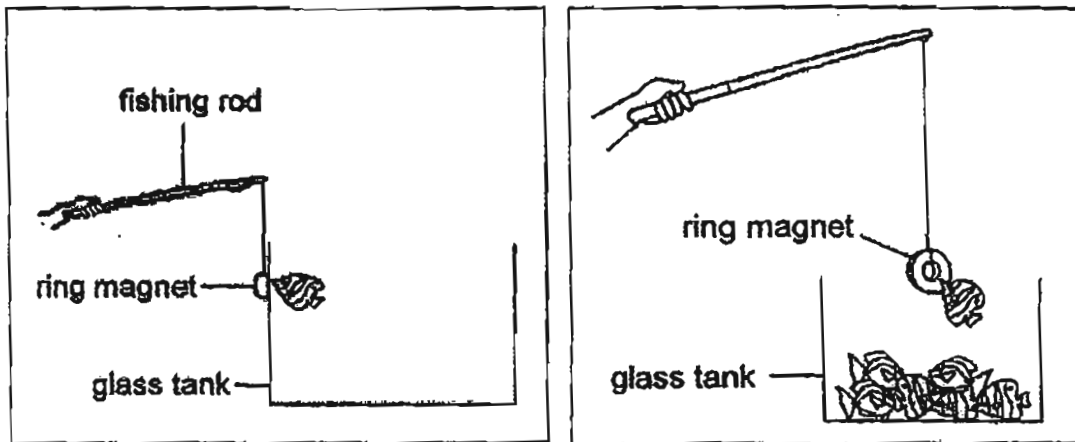

Based on the information above, answer the following questions :
Put a tick () in the correct box(es).

[2]

Statement	true	false	not possible to tell
The cut-outs were made of a magnetic material.	<input type="checkbox"/>	<input type="checkbox"/>	<input type="checkbox"/>
The paper clip was made of nickel.	<input type="checkbox"/>	<input type="checkbox"/>	<input type="checkbox"/>
Magnetism can pass through glass.	<input type="checkbox"/>	<input type="checkbox"/>	<input type="checkbox"/>
When the ring magnet was replaced with a bar magnet, it could not attract the paper clip on the cut-out.	<input type="checkbox"/>	<input type="checkbox"/>	<input type="checkbox"/>

END OF PAPER

Setters : Mrs Elaine Lim, Ms Florence Kong



ANSWER SHEET

EXAM PAPER 2011

**SCHOOL : RAFFLES GIRLS
SUBJECT : PRIMARY 3 SCIENCE**

TERM : SA 2

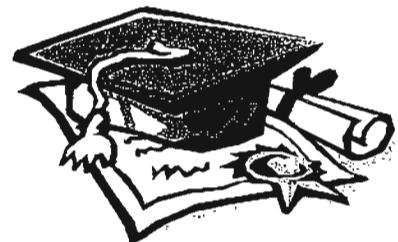

Section A

Q1	Q2	Q3	Q4	Q5	Q6	Q7	Q8	Q9	Q10	Q11	Q12	Q13	Q14	Q15	Q16	Q17
4	2	2	3	2	4	3	3	2	3	2	2	1	1	1	3	3

Q18	Q19	Q20	Q21	Q22	Q23	Q24
2	1	1	3	3	2	3

Section B

Q25 a) The fish grow longer from week 1 to week 4.

b) The length of the fish remain the same from week 4 onwards.

Q26 a) B. The lizard in set-up does not have air, food and water.

b) Living thing need air, food and water.

Q27 a) The body coverings of these animals protect them from injury.

b) Both animal have a pair of eyes.

Animal X has two legs but Animal Y has four legs.

Q28 a) i) Non-flowering (ii) fungi

b) X and Y reproduce by spores.

Q29 a)

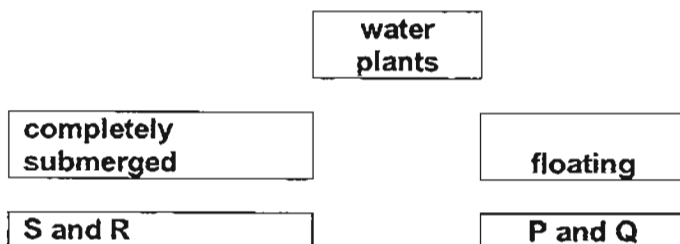

(b) P and Q block the sunlight and R and S could not make food.

Q30)

DIFFERENCE 1	Organism Y has 3 stages but organism Z has 4 stages.
DIFFERENCE 2	Organism Z has a larval stage but organism Y does not.

- Q31a) Egg stage.
 b) Pupa stage

Q32 a)

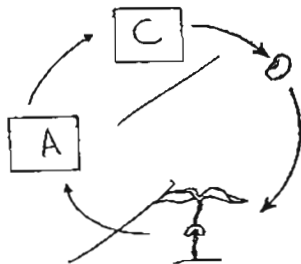

Q32b)

part of the seedling	function
seed out	the seed coat protect the seed.

Q33 a) the seedling in the pot in a box grow taller than the seedling in the pot under the light.

b) The seedling received light from all direction.

- Q34) Reason 1 : It is strong.
 Reason 2 : It does not break easily.

- Q35 a) Metal
 b) Q . It is the strongest and can hold the most number of balls before it broke.

- Q36 a) A. Because only magnets repel each other magnetic material cannot repel a magnet.
 b) C. Because it move towards car X like all magnetic materials, magnets can attracted them.

- Q37 a) (i) (ii) A
 b) 1st way – Put more batteries
 2nd way - Turn more coils.

Q38)

Statement	TRUE	FALSE	not possible to tell
The cut-outs were made of magnetic material.		√	
The paper clip was mafe od nickel.			√
Magnetism can pass through glass	√		
When the ring magnet was replaced with a bar magnet, it could not attract the paper clip on the cut-out.		√	