



# RAFFLES GIRLS' PRIMARY SCHOOL

## P3 SCIENCE

### SEMESTRAL ASSESSMENT (2)

Name: \_\_\_\_\_ Index No: \_\_\_\_\_ Class: P3 \_\_\_\_\_

Section A	48
Section B	32
Your score out of <b>80</b> marks	
Parent's signature	

30 October 2017

SCIENCE

ATT: 1 h 15 min

#### SECTION A (24 x 2 marks)

For each question from 1 to 24, four options are given.

One of them is the correct answer. Make your choice (1, 2, 3 or 4).

Shade the correct oval (1, 2, 3 or 4) on the Optical Answer Sheet (OAS) provided.

1. Which of the following statements about all living things are correct?

- A They can reproduce.
- B They can make their own food.
- C They can respond to changes.
- D They give birth to their young alive.

- (1) A and C only
- (2) B and D only
- (3) A, C and D only
- (4) A, B and C only

2. The flowchart below shows how things are classified.

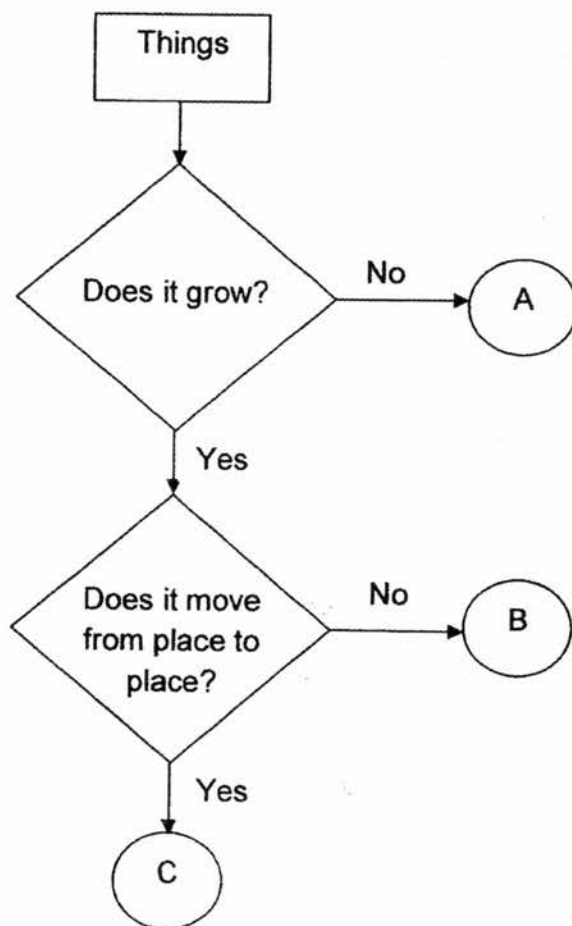

Based on the information above, which of the following best represents plant, marble and ant?

	Plant	Marble	Ant
(1)	A	B	C
(2)	A	C	B
(3)	B	A	C
(4)	C	B	A

3. Some pupils found Animal T in the school field.



After making some observations about Animal T as shown above, the pupils concluded that Animal T is an insect.

The following observations were made by the pupils:

Pupil A : It is hairy.



Pupil B : It has six legs.

Pupil C : It has three body parts.

Which pupils gave the correct observations that Animal T is an insect?

- (1) A and B only
- (2) B and C only
- (3) A and C only
- (4) A, B and C

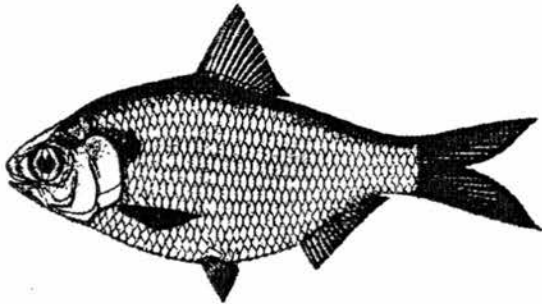
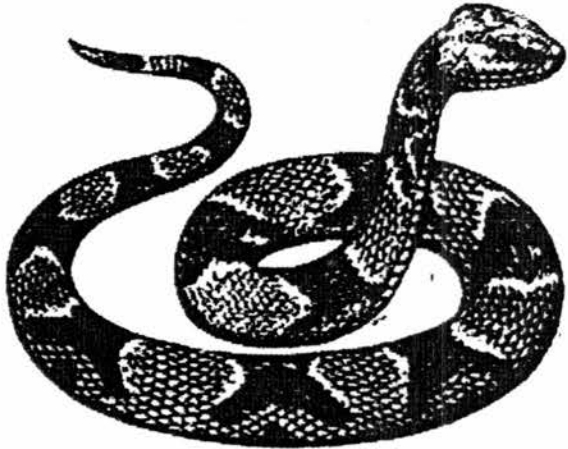
4. The animals below are grouped according to one common physical characteristic.

	
<p>Animal W</p>	<p>Animal X</p>
	
<p>Animal Y</p>	<p>Animal Z</p>

Based on your observations, which one of the following animals does **NOT** belong to the group?

- (1) Animal W
- (2) Animal X
- (3) Animal Y
- (4) Animal Z

5. The classification chart shows some animals which are not drawn to scale.

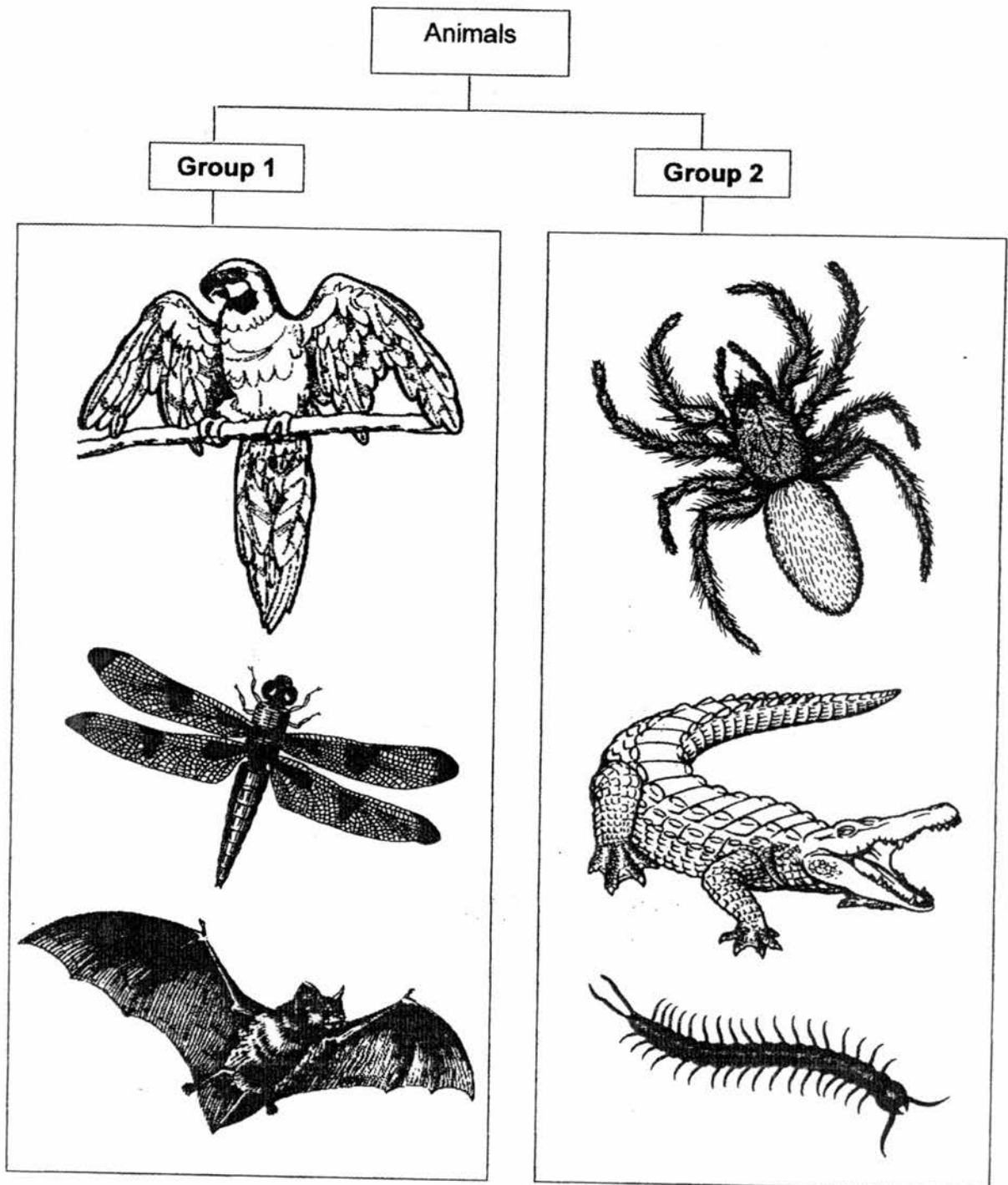

Continued on next page

Continued from previous page

Which of the following shows the correct headings of how the animals are grouped?

	<b>Group 1</b>	<b>Group 2</b>
(1)	Does not have a tail	Has a tail
(2)	Has wings	Does not have wings
(3)	Has hair	Does not have hair
(4)	Does not have four legs	Has four legs

6. Study the flowchart below carefully.

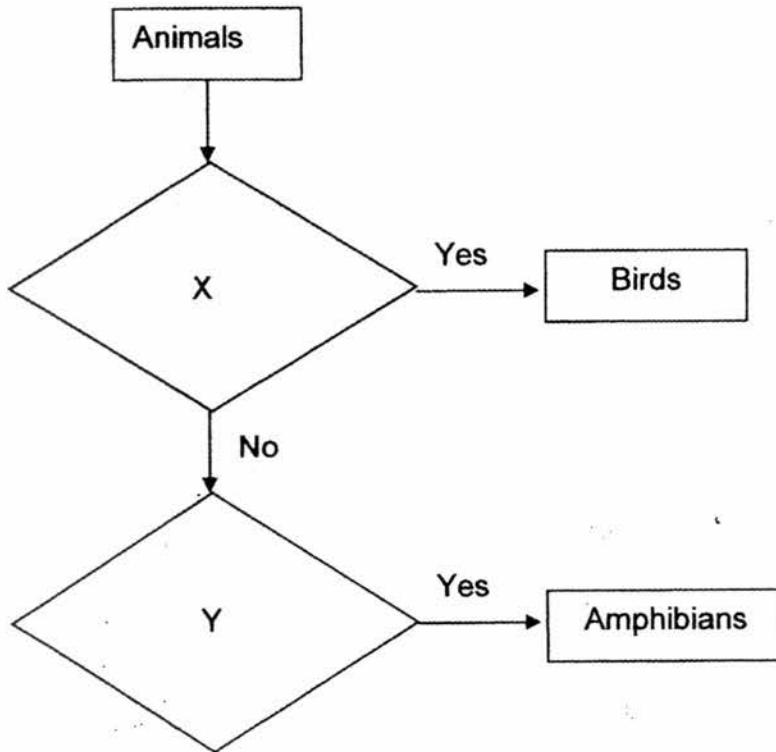

Which of the following best represent X and Y?

	X	Y
(1)	Does it have beak?	Does it have scales on its body?
(2)	Does it have wings?	Does it have hair on its body?
(3)	Does it have hair on its body?	Does it have moist skin?
(4)	Does it have feathers on its body?	Does it live both on land and in water?

7. The classification chart shows how some organisms are classified.

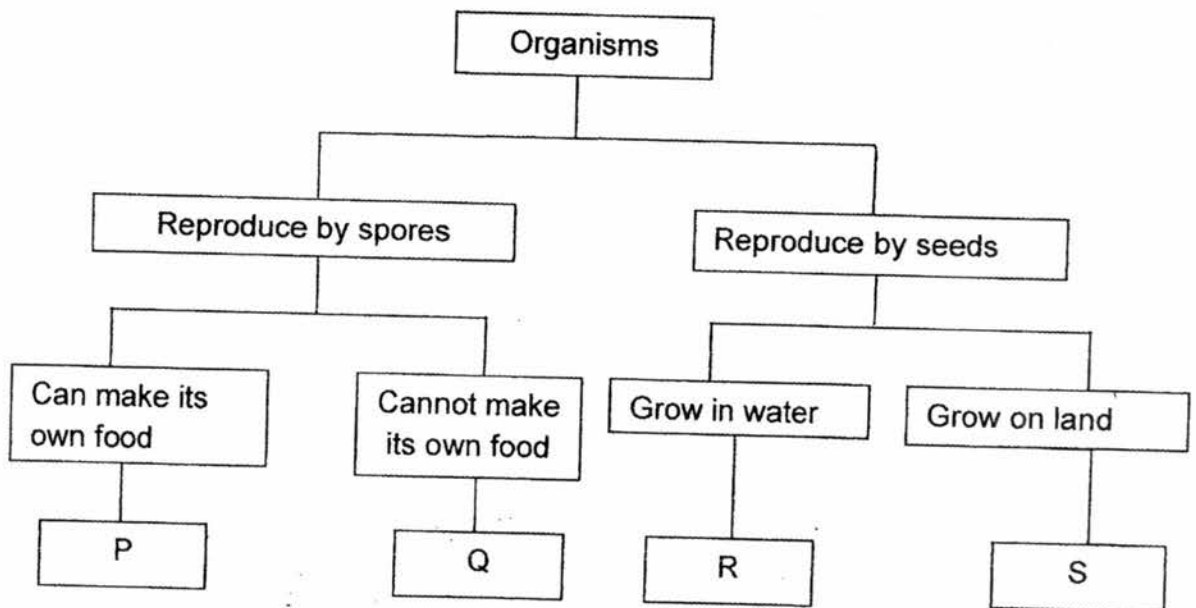

Which one of the following correctly represents bread moulds?

- (1) P
- (2) Q
- (3) R
- (4) S



8. The diagram below shows two plants, X and Y.

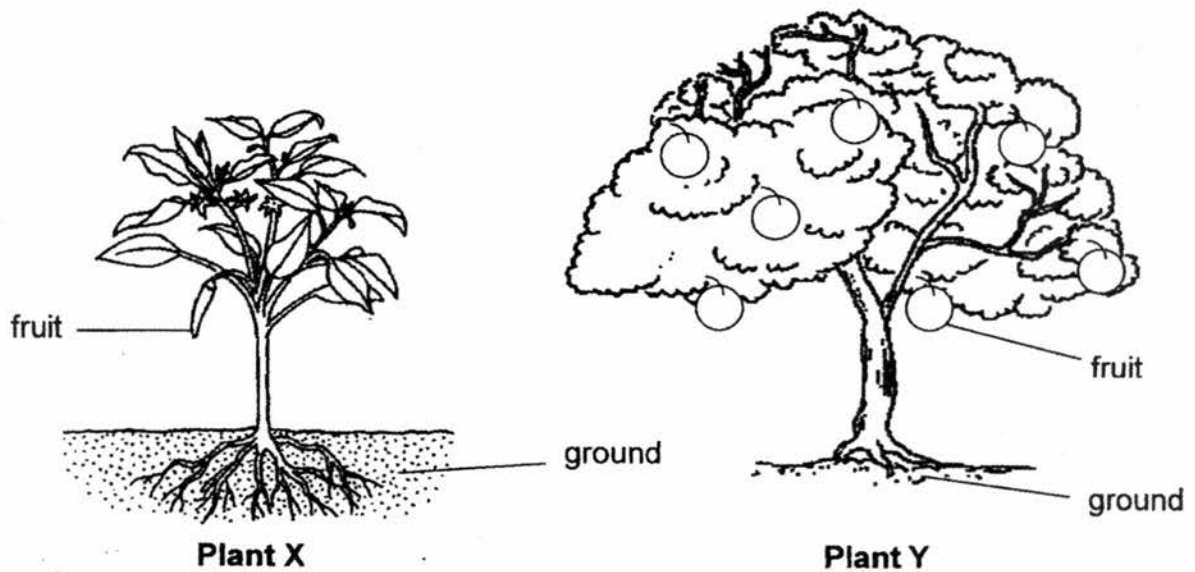

Based on your observations, what are the similarities between plants X and Y?

- A Both are land plants.
- B Both are non-flowering plants.
- C Both plants reproduce by seeds.

- (1) A and B only
- (2) A and C only
- (3) B and C only
- (4) A, B and C only

9. Which one of the following describes mushroom and bacteria correctly?

- (1) Both reproduce by seeds.
- (2) Both can make their own food.
- (3) Both do not need food and water.
- (4) Both can respond to changes in their surroundings.

10. The diagram below shows the life cycle of a mosquito.

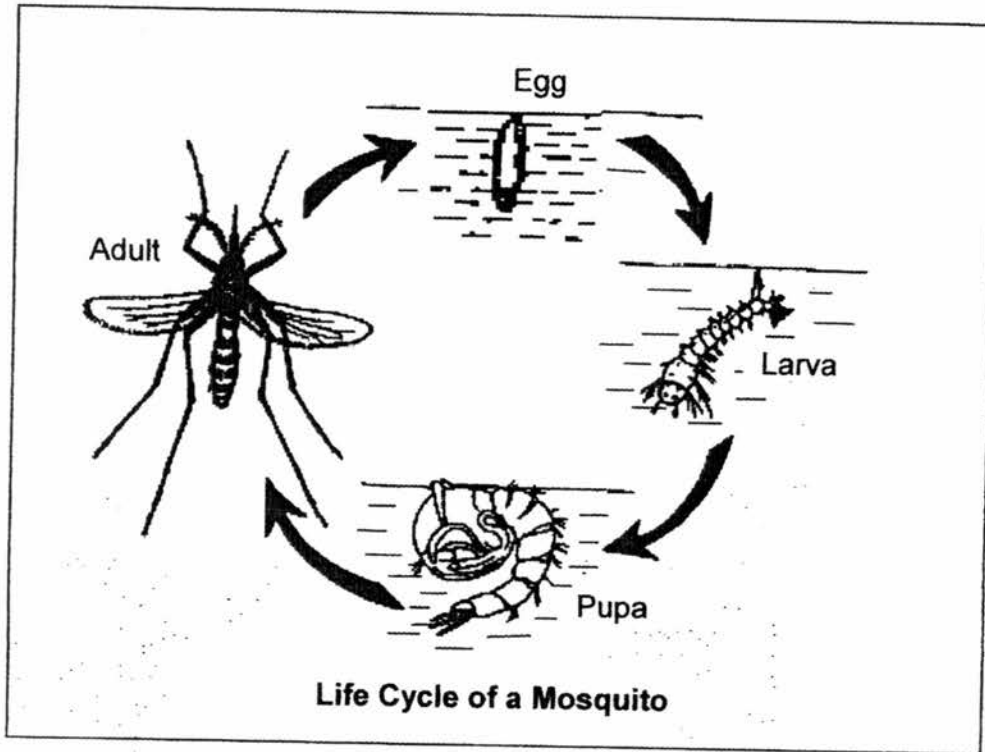

Based on the information above, which one of the following statements on the life cycle of the mosquito is **true**?

- (1) The mosquito has four stages in its life cycle.
- (2) The adult mosquito lives on land and in water.
- (3) The young of the mosquito resembles the adult.
- (4) Only one stage of the life cycle of the mosquito is spent in water.

11. Study the flowchart below carefully.

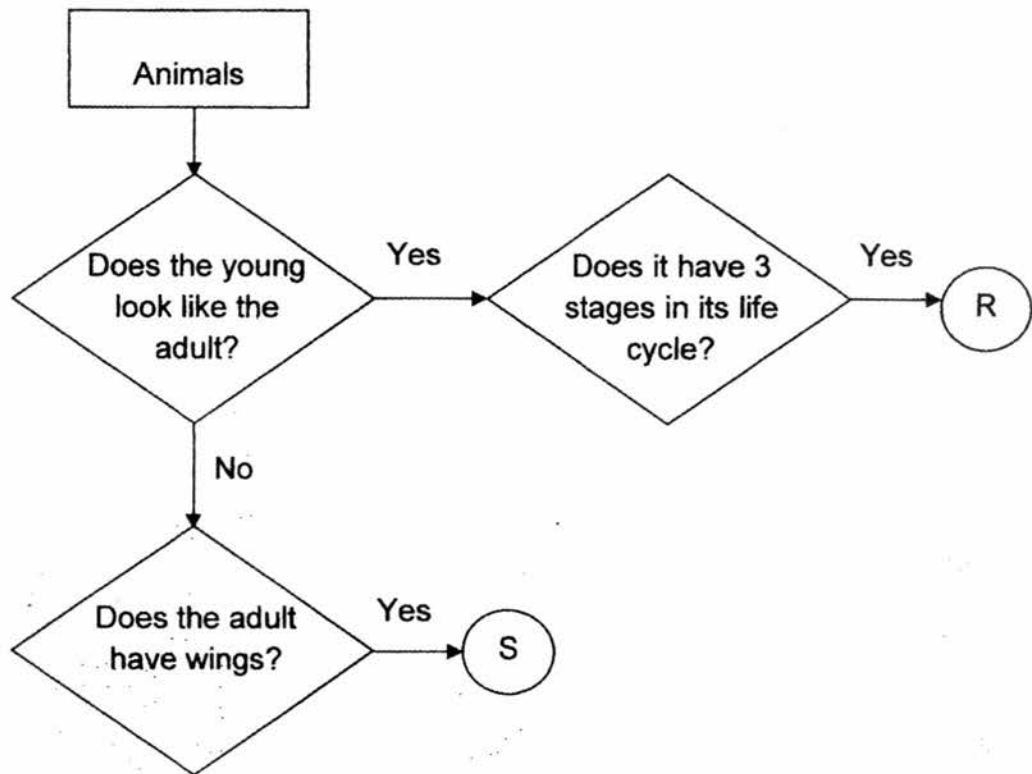

Based on the information above, which one of the following identifies animals R and S correctly?

	R	S
(1)	mosquito	beetle
(2)	mosquito	frog
(3)	grasshopper	frog
(4)	chicken	beetle

12 Jane made the following statements about the life cycle of a butterfly.

- A The young of a butterfly looks like its adult.
- B It eats a lot when it is at the larva stage.
- C It starts to develop its wings at larva stage.

Which of the following statements on the life cycle of the butterfly is/are **true**?

- (1) A only
- (2) B only
- (3) B and C only
- (4) A and B only

13. The diagram below show the different stages of development of a plant, not in the correct order.

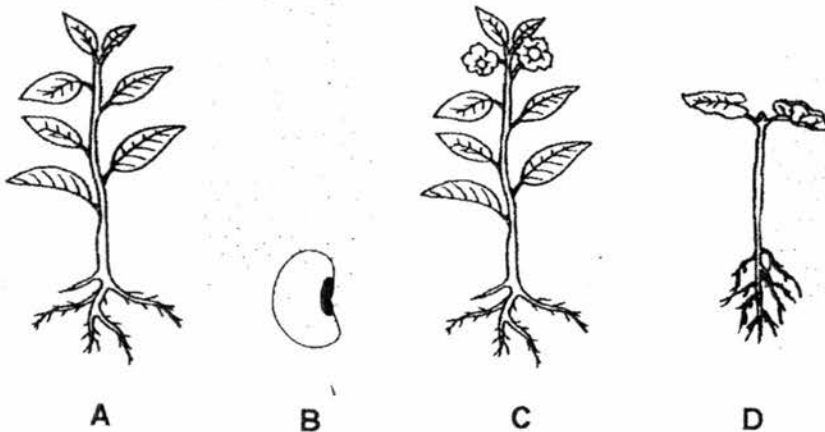

Which of the following correctly shows the correct order of development of the plant?

- (1) A → C → D → B
- (2) B → D → A → C
- (3) C → D → B → A
- (4) D → C → A → B

14. Mary placed an identical seed in each of the four set-ups, A, B, C and D. She exposed the four set-ups to different conditions as shown below.

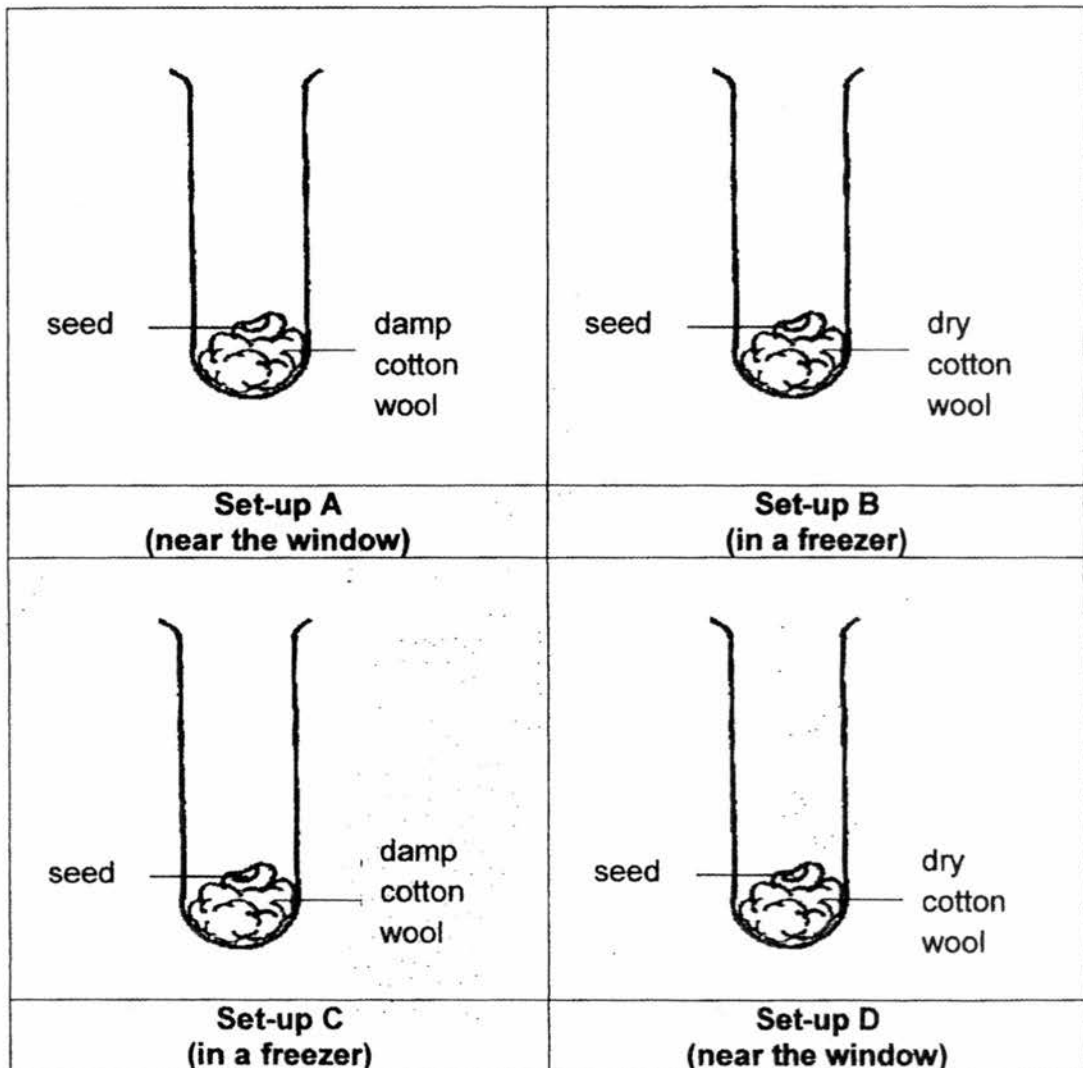

In which of the set-ups, A, B, C or D, will the seed most likely to grow after some time?

- (1) Set-up A
- (2) Set-up B
- (3) Set-up C
- (4) Set-up D

15. Jane wanted to observe the development of a seed into a seedling. She placed the seed in a container of soil and watered it daily to keep the soil moist. The mass of part A of the seed was recorded on the first day was 2g. Then she recorded the mass of part A after five days.

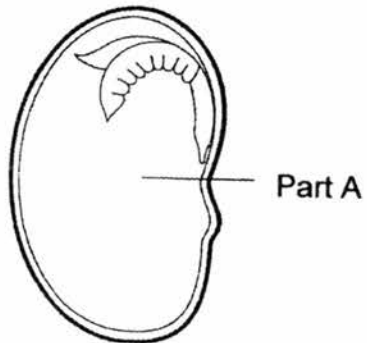

The mass of part A of the seed at the end of five days was most likely to be

\_\_\_\_\_.

- (1) 0g
- (2) 2g
- (3) less than 2g
- (4) more than 2g

16. The diagram below shows a pool ping pong table.

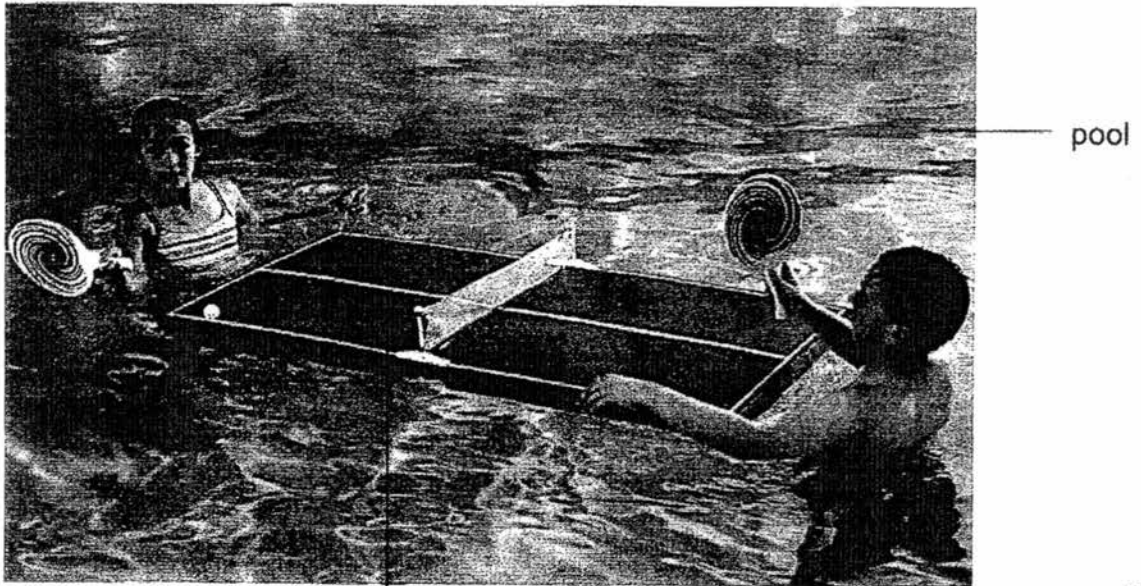

pool ping pong table

Which one of the following materials and its given property should be taken into consideration while selecting it to make the pool ping pong table?

	Material	Property
(1)	A	It is strong.
(2)	B	It is absorbent.
(3)	C	It is able to float.
(4)	D	It allows light to pass through.

17. Katy wanted to choose a suitable material for Part X of the bookshelf as shown below.



The properties of materials A, B, C and D are as shown in the table below. A tick (✓) shows the presence of the property.

Materials / Properties	A	B	C	D
Strong	✓	✓		
Flexible	✓			✓
Waterproof	✓	✓	✓	✓

Which of the following is the most suitable material for making Part X of the bookshelf?

- (1) Material A
- (2) Material B
- (3) Material C
- (4) Material D.



18. Peter wanted to compare the flexibility of four strips, A, B, C and D, made of different materials. He bent the strips and measured the maximum distance,  $d$ , which it could bend before it started to break.

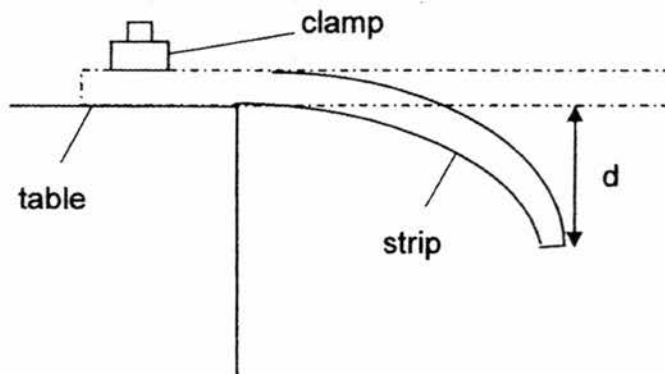

He recorded the results in the table below.

Material	Distance, $d$ (cm)
A	9
B	4
C	12
D	3

Based on the results above, which one of the following statements is correct?

- (1) Material C is the least flexible.
- (2) Material D is the most flexible.
- (3) Material A is more flexible than Material B.
- (4) Material D is more flexible than Material C.

19. Ali conducted an experiment using magnets, K and L, of different shapes. He placed each magnet at the same distance above a tray containing identical number of metal clips. The diagrams below show his observations.

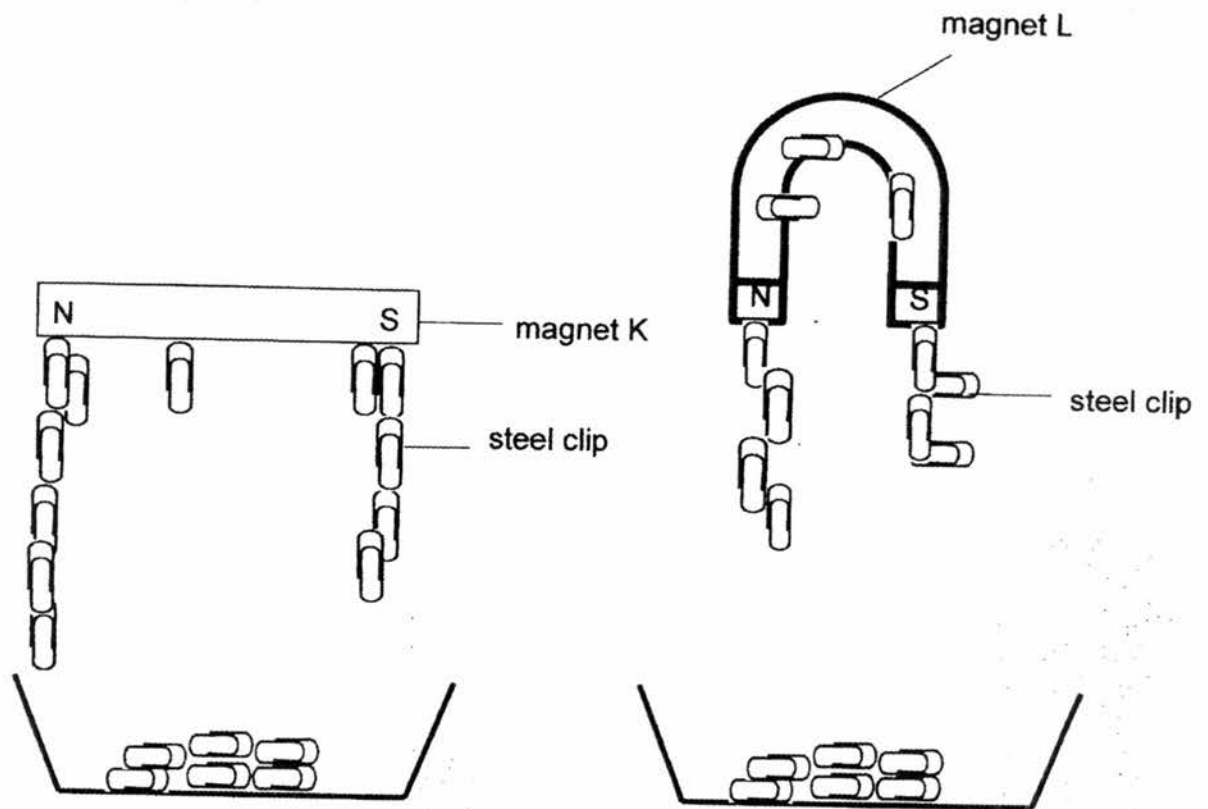

Based on his observations above, which of the following statements are correct?

- A The steel clip is magnetic.
- B The magnet is strongest at its poles.
- C Magnet L is stronger than magnet K.
- D Magnet L and K are equally strong.

- (1) A and B only
- (2) A and D only
- (3) B and C only
- (4) A, C and D only

20. Mr Tan carried out a test to observe the interaction between a magnet and objects A, B and C.

He placed one end of the magnet near each object and recorded his observations in the table as shown below.

Object	Moved towards the magnet	Moved away from the magnet	No interaction
A	√		
B			√
C	√	√	

Based on his observations, which one of the following statements is definitely true?

- (1) Only object C is a magnet.
- (2) Object B is made of iron.
- (3) Object A and C are magnets.
- (4) Objects A and B are made of magnetic materials.

21. The diagram below shows two toy cars, A and B. Each toy car has a bar magnet fixed on it as shown below. The diagram shows the interaction between Compass X and the bar magnet on car A. When the two toys cars were brought close to each other, they moved towards each other.

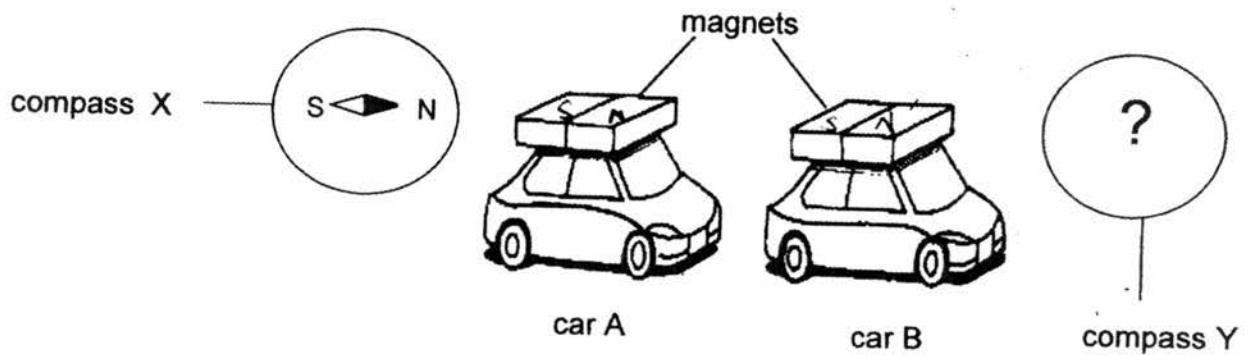

Which one of the following diagrams shows the correct position of the needle on compass Y?

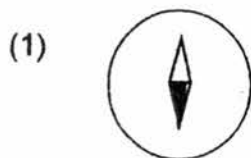

22. Three bar magnets with their poles marked A to F are arranged as shown below.

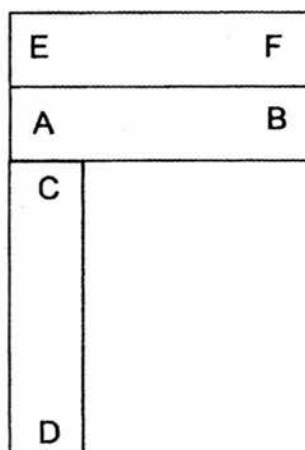

Based on the above arrangement, which one of the following identifies the poles correctly?

	<b>N - poles</b>	<b>S - poles</b>
(1)	A and F	C and E
(2)	B and C	D and E
(3)	B and D	A and E
(4)	C and E	B and D

23. Joy wanted to find out if the number of coils around an iron rod affects its magnetic strength. She used identical batteries and rods in her set-ups.

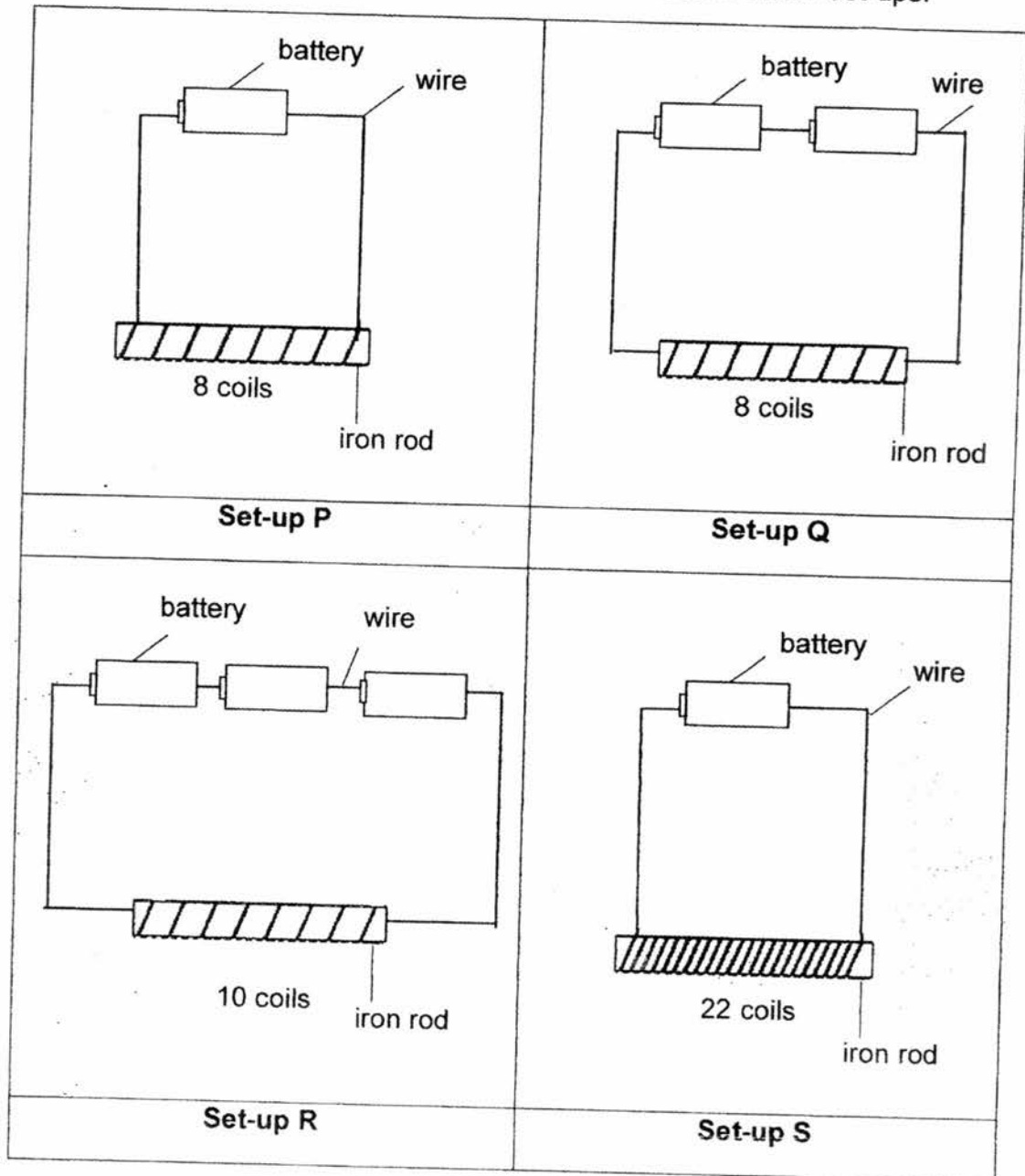

Which two set-ups should Joy use to ensure a fair test?

- (1) P and R
- (2) P and Q
- (3) R and S
- (4) P and S

24. The diagram below shows a machine which can be used to separate some items.

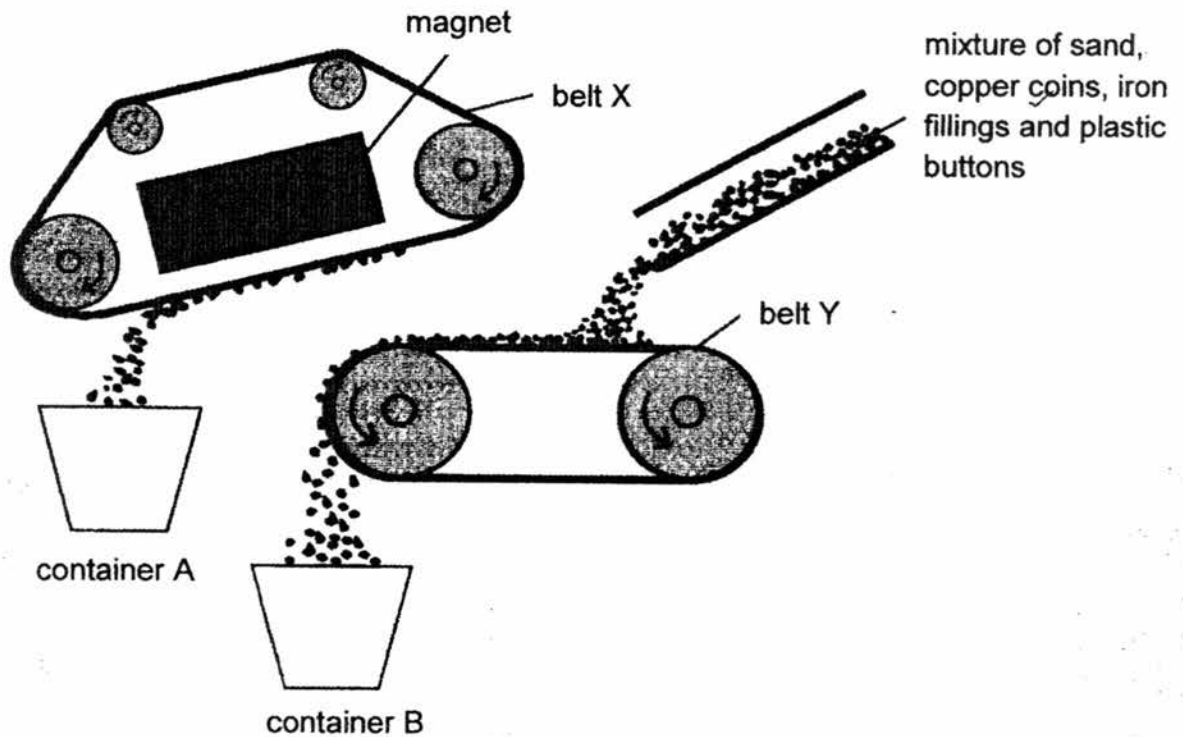

Which of the following objects can be found in container B?

- (1) Iron fillings only
- (2) Sand and plastic buttons only
- (3) Iron fillings and copper coins only
- (4) Sand, copper coins and plastic buttons only

Name; \_\_\_\_\_ ( )

Class: P 3 ( )

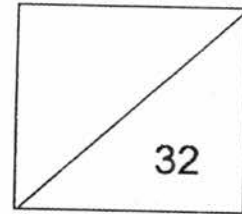



**SECTION B (32 marks)**

For questions 25 to 37, write your answers clearly in the spaces provided. The number of marks available is shown in brackets [ ] at the end of each question or part question.

25. Tina observed three living things in her garden and recorded their characteristics as shown in the table below.  
A tick (✓) shows the presence of that characteristic in the living things.

Living things	A	B	C
Needs water	✓	✓	✓
Make their own food		✓	
Reproduce from spores			✓
Can move from one place to another	✓		

Which of the following A, B or C, represents the living things below? [2]

Living things	Letter
(a) 	
(b) 	

Score	2
-------	---



26. Peter kept two mice in a cage over a period of time. He fed them with the same amount of food and water every day. The graph below shows the number of mice in the cage over a period of five months. No mice were added or removed from the cage during these five months.

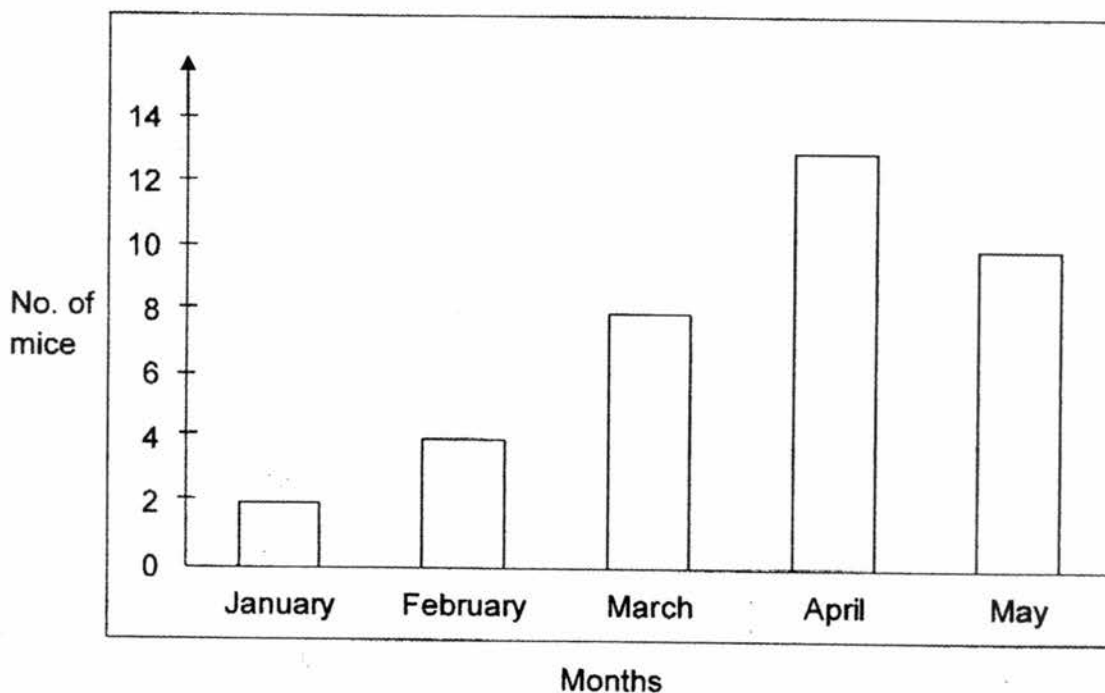

- (a) What is the characteristic of living things observed from January to April? [1]

---

---

- (b) Suggest a possible reason for the change in the number of mice from April to May. [1]

---

---

Score	2
-------	---

27. Study animals X and Y in the diagrams below.

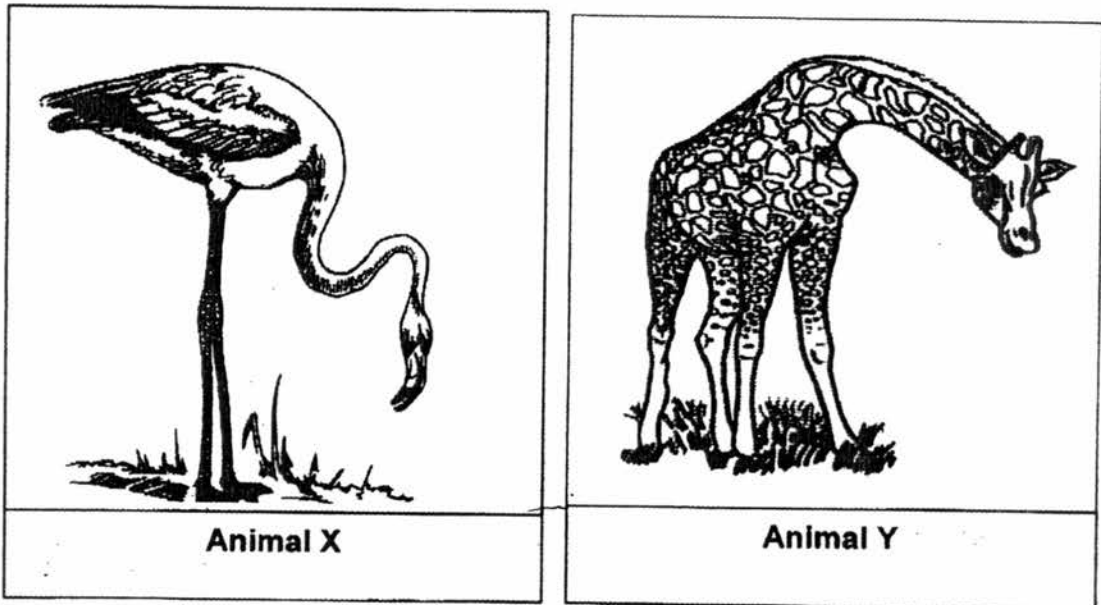

Based on your observations only, state one similarity and one difference between the physical characteristics of animals X and Y.

(Do **NOT** compare body shapes, sizes, patterns and colours.)

[2]

Similarity	<hr/> <hr/> <hr/>
Difference	<hr/> <hr/> <hr/>

Score	2
-------	---

28. Study the three groups of animals in the classification table below.

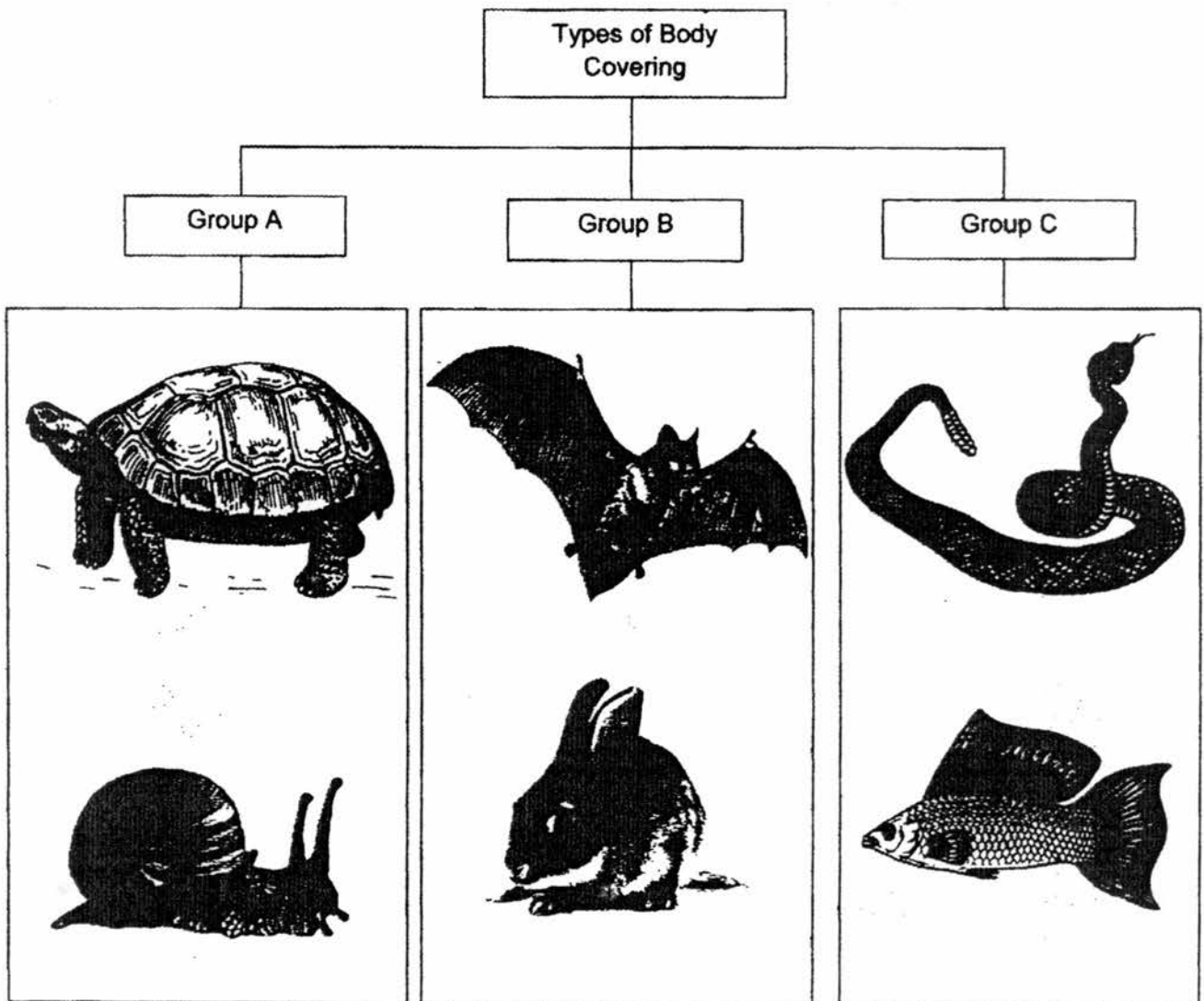

Continued on the next page

Continued from previous page

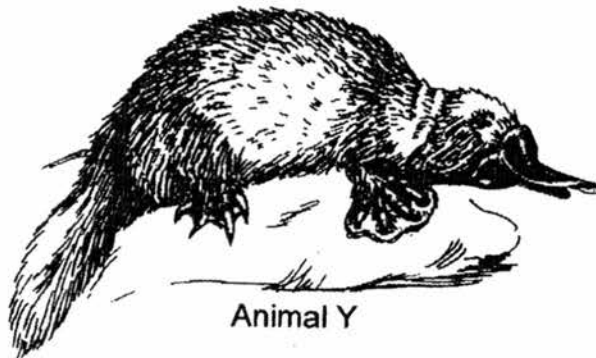

Animal Y

- (a) Which group, A, B or C, does Animal Y belong to? Give a reason for your answer. [1]

---

---

- (b) Write the suitable heading for the following groups. [2]

(i) Group A : \_\_\_\_\_

(ii) Group C : \_\_\_\_\_

Score	3
-------	---

29. The diagram below shows a coconut tree and a toadstool.

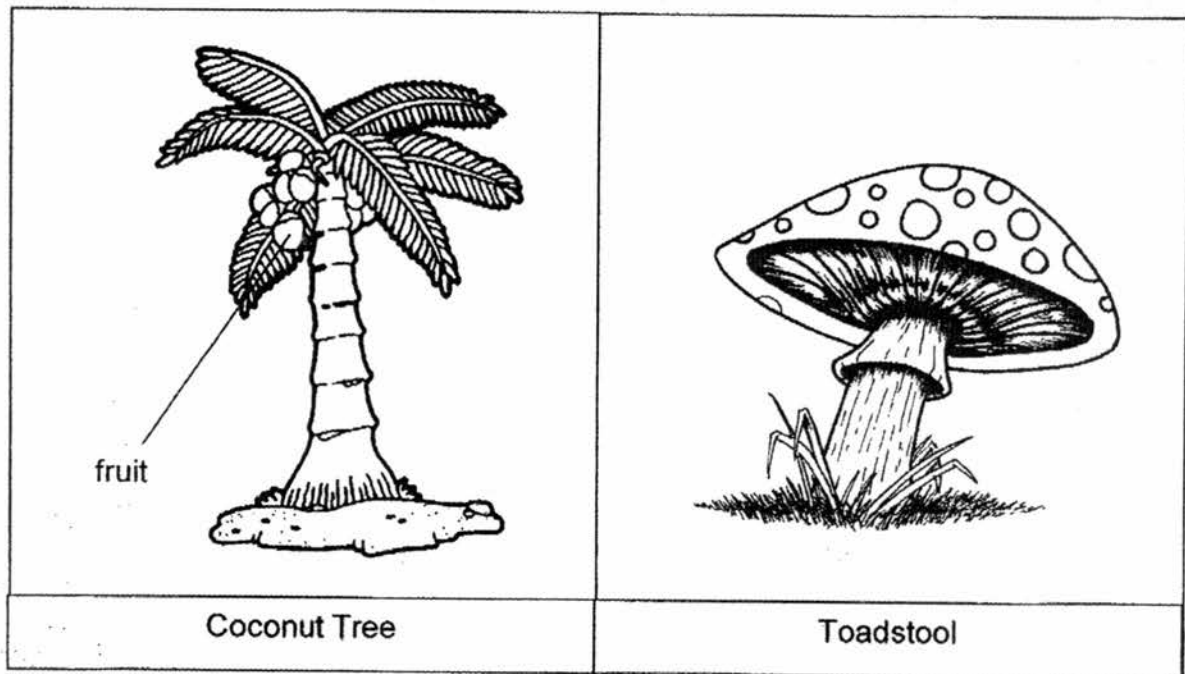

(a) State the way in which the coconut tree and toadstool reproduce. [1]

Coconut tree	It reproduces by _____.
Toadstool	It reproduces by _____.

(b) Name one plant that reproduces the same way as the toadstool. [1]

\_\_\_\_\_

Score	2
-------	---

30. Study the following plants carefully.

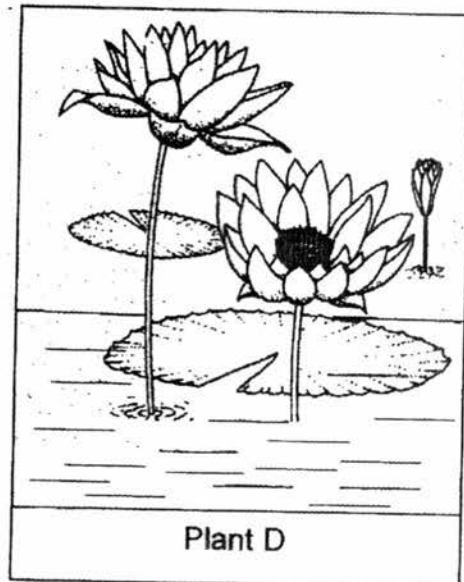
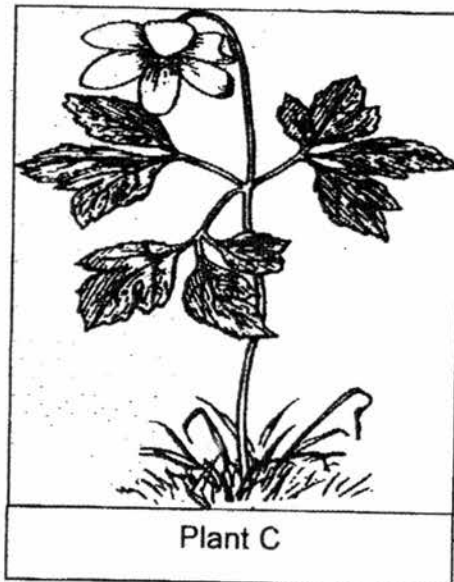
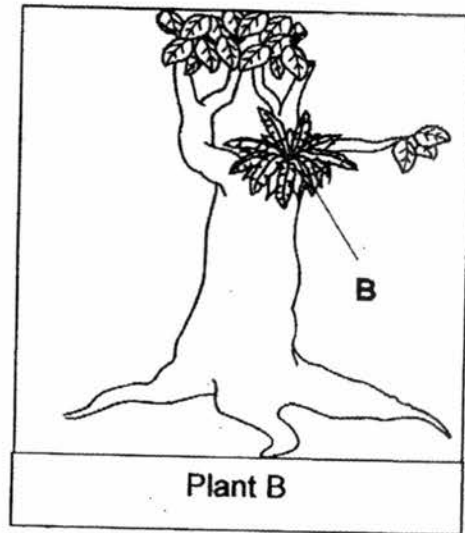
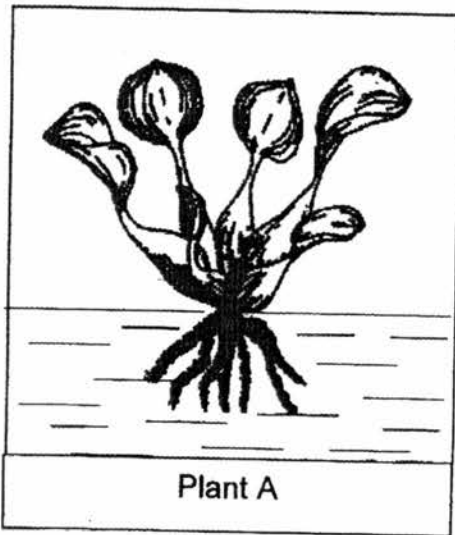

Continued on the next page

**Continued from previous page**

Group the plants, A, B, C and D into the two groups shown in the classification table below.

- (a) Write the letters, A, B, C and D in the correct boxes below. [2]

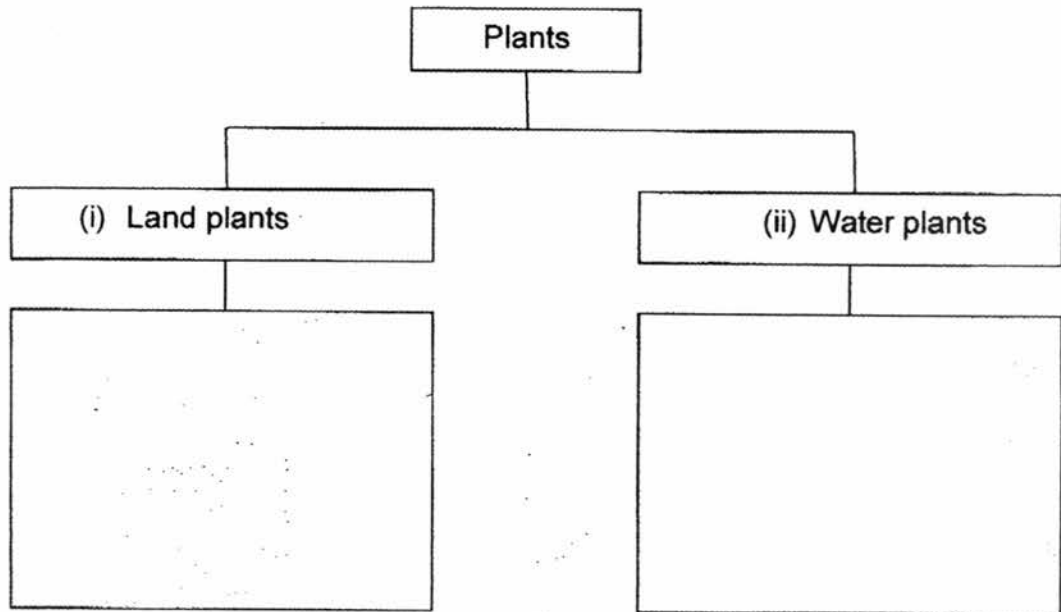

- (b) What is another way of grouping plants A, B, C and D? Write the suitable sub-headings in the classification table below. [1]

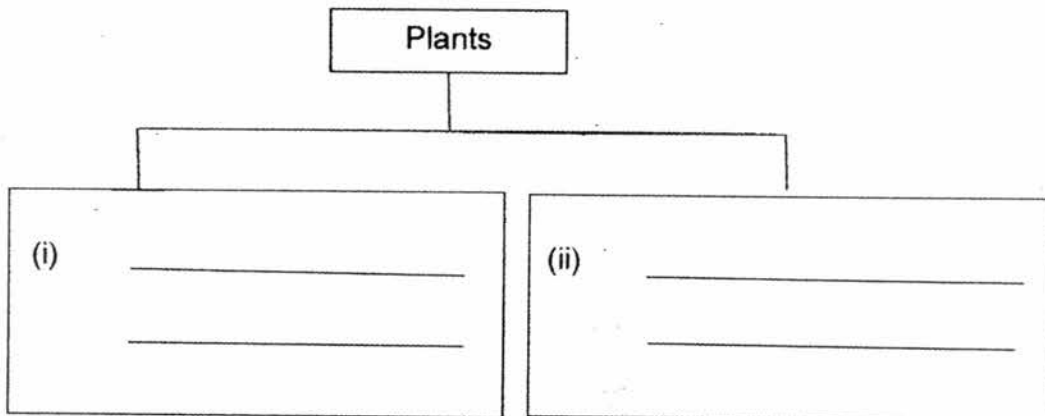

Score	3
-------	---

31. The life cycles of animals Y and Z are shown in the diagrams below.

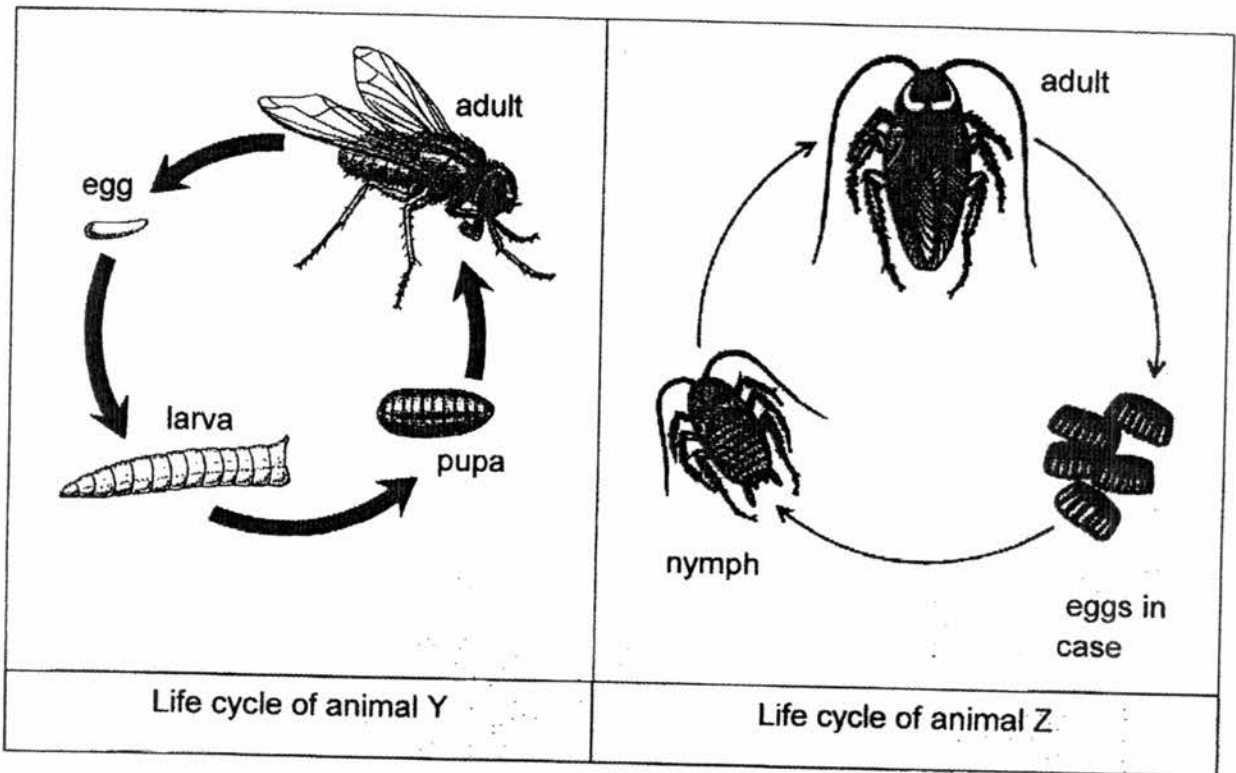

Based on the information above, state one similarity and one difference between the two life cycles shown above.

[2]

(i)	Similarity	<hr/> <hr/> <hr/> <hr/>
(ii)	Difference	<hr/> <hr/> <hr/> <hr/>

Score	2
-------	---



32. The diagram below shows the life cycle of Organism Q.

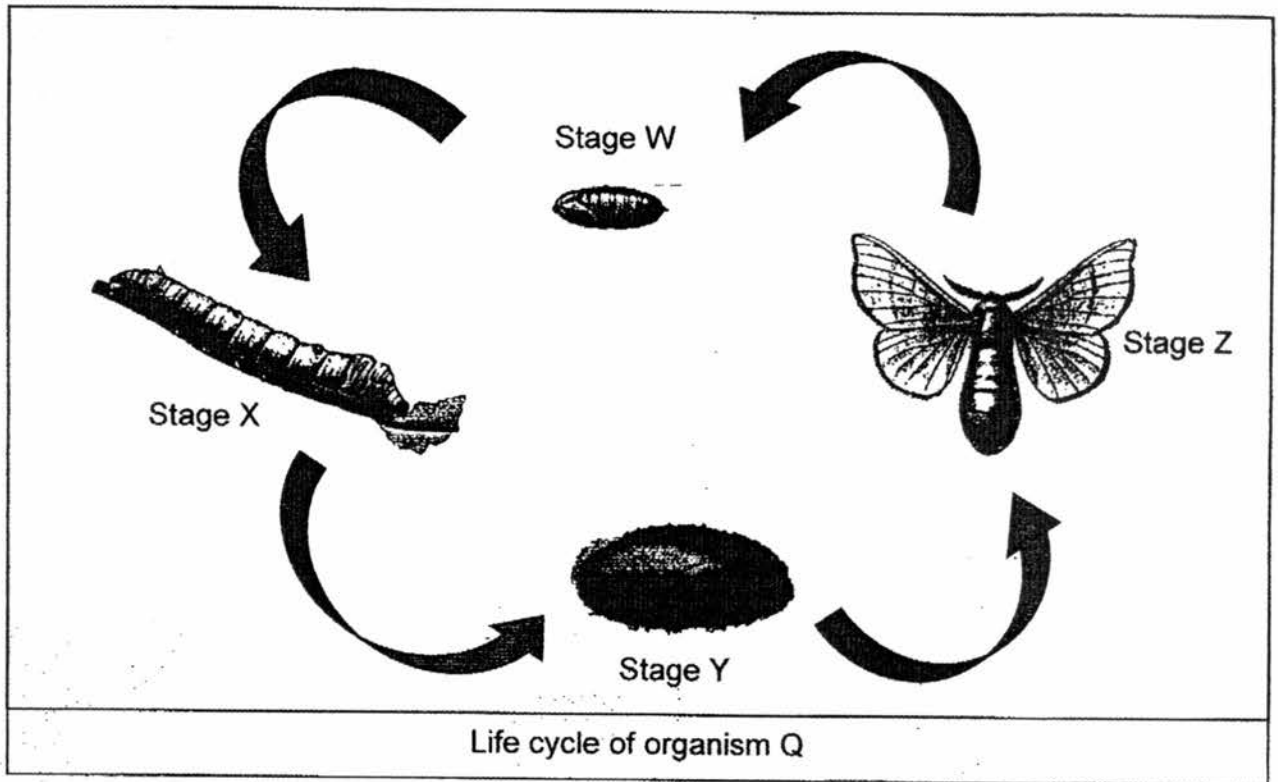

(a) Based on the information above, name stage X and Y of the life-cycle of organism Q. [2]

(i) Stage X.: \_\_\_\_\_

(ii) Stage Y : \_\_\_\_\_

(b) Organism Q may be a danger to humans with its poisonous sting.

Which stage of its life cycle, Stage X, Y or Z, would it be most difficult to get rid of organism Q? Give a reason for your answer. [2]

\_\_\_\_\_

\_\_\_\_\_

Score	/
	4

33. The diagram below shows different parts of the germinating seed.

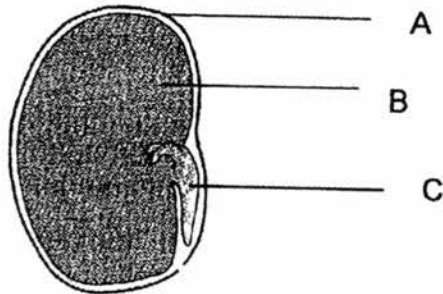

(a) Which part of the seed, A, B or C, protects the seed? [1]

---

(b) Which part of the seed, A, B or C, stores food? [1]

---

Score	2
-------	---

34. Ahmad prepared two set-ups using identical type of seeds. He placed identical number of seeds on the damp cotton wool in each set-up.

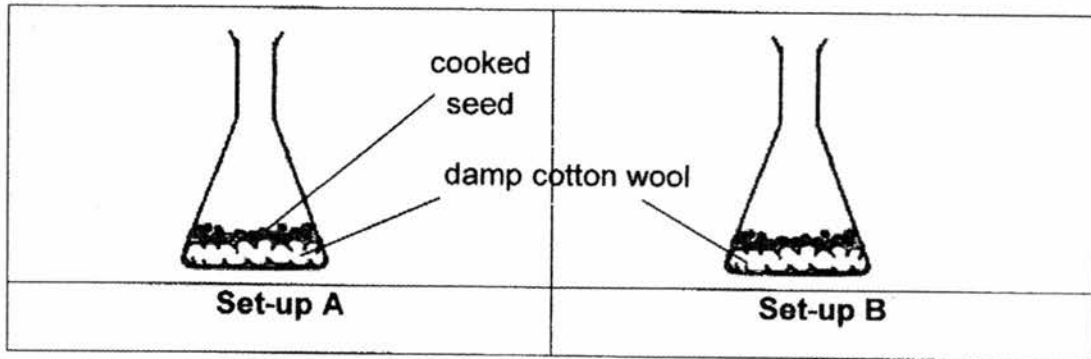

- (a) State **all** the conditions needed for seeds to grow.

[1]

---

- (b) He observed the cooked seeds in set-up A did not grow.  
Give a reason for his observation.

[1]

---

---

Score	2
-------	---

35. Materials P, Q, R and S are classified in the chart below.

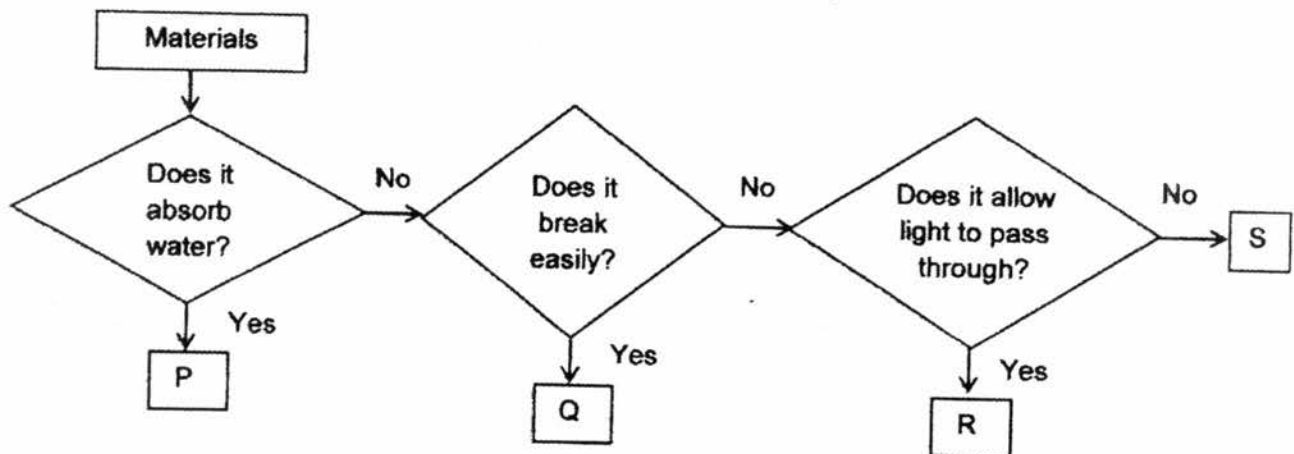

The diagram shows an underwater restaurant where customers can see the sea creatures swimming around while enjoying their meals.

Part X



Continued on next page

Continued from previous page

(a) Based on the chart, describe the properties of material Q. [1]

---

---

(b) Sally said material S is most suitable to make part X of the underwater restaurant. Do you agree? Give a reason for your answer. [1]

---

---

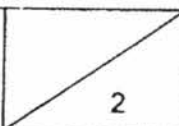
Score	
-------	---

2017 P3 Science SA2

For questions 36(a) and 36(b), refer to the diagram and table below.

36. Sarah conducted an experiment as shown below. She hung four different materials, P, Q, R and S, of identical size and thickness in a container of water as shown below.

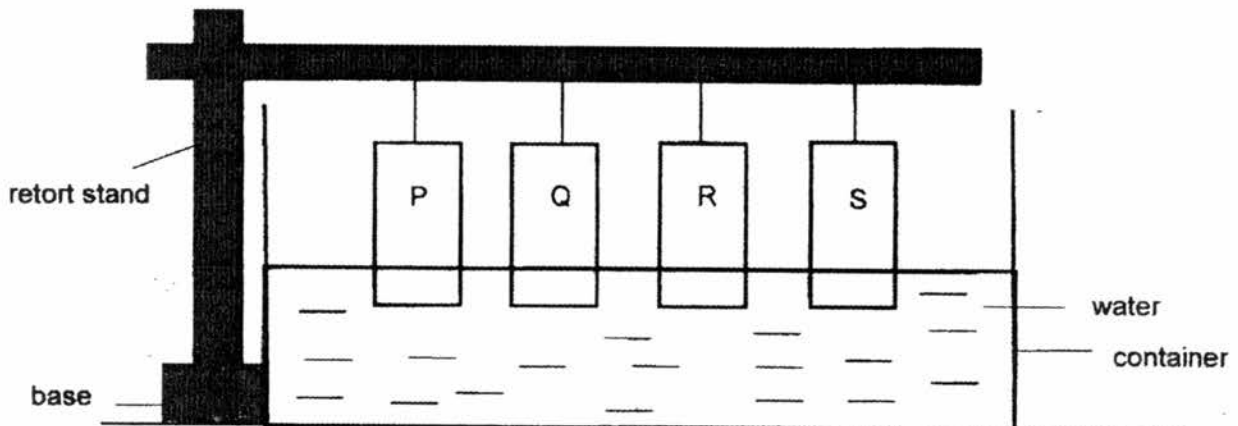

After ten minutes, she removed the strips from the set-up and measured their masses and recorded the results in the table below.

Material of strip	Initial mass (g)	Mass after 10 minutes (g)
P	100	180
Q	100	150
R	100	165
S	100	100

Continued on next page

Continued from previous page



Rain boots

Based on the information provided in the table, answer the following questions.

- (a) Which material, P, Q, R or S, is most suitable to be used to make a pair of rain boots shown above? Give a reason for your answer. [1]

---

---

The diagram below shows a mop.



- (b) Which material, P, Q, R or S, is most suitable to be used to make part Z of the mop? Give a reason for your answer. [1]

---

---

Score	2
-------	---

37. Cynthia used three ring magnets, A, B and C, to prepare an experimental set-up. She observed the interactions between the three ring magnets as shown below.

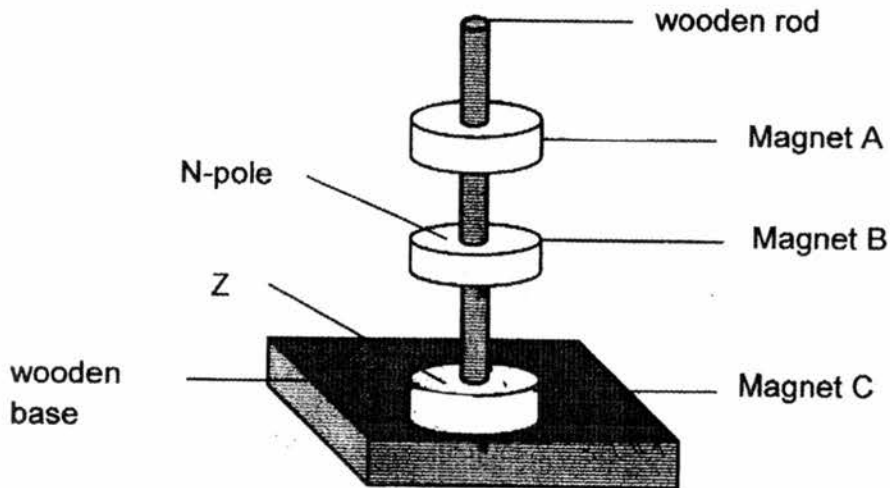

Based on her observations above, answer the following questions.

- (a) Identify the pole labelled Z in Magnet C.

[1]

---

- (b) Cynthia made the following statement:

“When Magnet B is removed from the set-up, both magnet A and C will attract each other.”

Do you agree with her? Give a reason for your answer.

[1]

---

---

Continued on next page

Score	2
-------	---



Continued from previous page.

- (c) Cynthia removed Magnet A from the set-up shown below and hammered it fifty times. She then placed it back into the set-up like before.

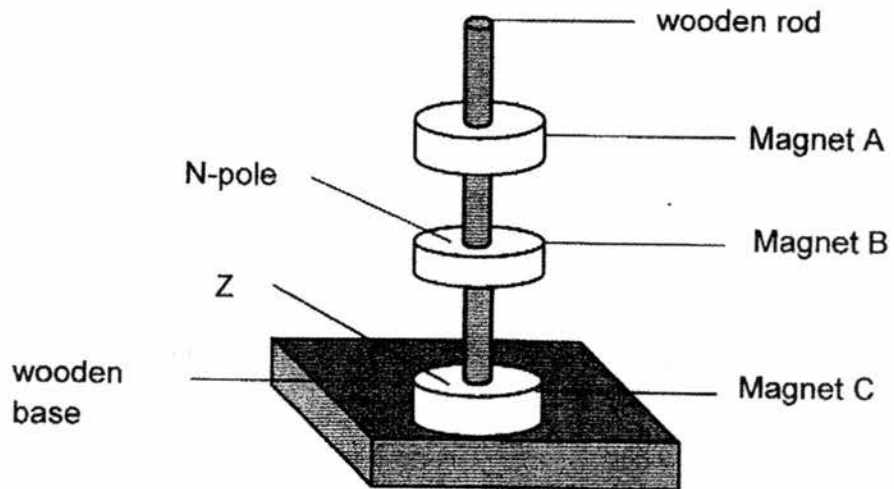

Describe the change that Cynthia would observe. Give a reason for your answer. [2]

---

---

Score	2
-------	---

- End of Paper -

# ANSWER KEY

**YEAR : 2017**  
**LEVEL : PRIMARY 3**  
**SCHOOL : RAFFLES GIRLS' PRIMARY SCHOOL**  
**SUBJECT : SCIENCE**  
**TERM : SA2**

**SECTION A (24 x2marks)**

Q 1	Q 2	Q 3	Q 4	Q 5	Q 6	Q 7	Q 8	Q 9	Q 10
1	3	2	4	2	4	2	2	4	1
Q 11	Q 12	Q 13	Q 14	Q 15	Q 16	Q 17	Q 18	Q 19	Q 20
4	2	2	1	3	3	2	3	1	1
Q21	Q 22	Q 23	Q 24						
3	1	4	4						

**SECTION B (32marks)**

Q25.a) A

b) B

Q26.a) living things reproduce      b) Some mice died

Q27. Similarity: X and Y both have a long neck  
 Difference: X has only two legs while Y has four legs

Q28.a) Group B. It has hair as a body covering.

b) i) Shell      ii) Scales

Q29.a) Coconut tree : It reproduces by seeds  
 Toadstool : It reproduces by spores.

b) Ferns

Q30.a) i) B, C      ii) A, D

b) i) Flowering plant  
 ii) Non-flowering plant

Q31. i) They both have an egg stage  
 ii) Z has a 3 stage life cycle while Y has a 4 stage life cycle.

Q32.a) i) Larva  
 ii) Pupa

b) Stage Z. At stage Z, which is the adult stage, Organism Q has wings and it will be able to fly.

Q33.a) A      b) B

Q34.a) Air , water and warmth

b)The cooked seed did not grow because it was already dead.

Q35.a) It absorbs water and it break easily

b)No. If it does not allow light to pass through the customer would not be able to look at the sea creatures.

Q36.a) S. It is waterproof

b)P. It absorbed the most water

Q37.a) South-pole

b)Yes. The North and south pole of the magnets are facing each other so it will attract each other.

c) It would not be repelled by magnet B anymore as magnet A has lost its magnetism.

