



PEI HWA PRESBYTERIAN PRIMARY SCHOOL
SEMESTRAL ASSESSMENT 2

PRIMARY 4
MATHEMATICS PAPER

27 OCT 2015

Name : _____

Form Class / Register No. : 4TW _____ / _____

Banded Class / Register No. : 4M _____ / _____

Total time: 1 h 45 min

INSTRUCTIONS TO CANDIDATES

1. Write your Name, Class and Register No. in the spaces provided above.
2. DO NOT turn over this page until you are told to do so.
3. Follow all instructions carefully.
4. Answer all questions.
5. For Section A, shade your answers on the Optical Answer Sheet (OAS) provided.
6. For Section B and C, write all your answers in this booklet
7. The use of calculator is **NOT ALLOWED**.

Total Marks :

100

This booklet consists of 18 printed pages, excluding the cover page.

Section A: Multiple Choice Questions (20×2 = 40 marks)

For each question, four options are given. One of them is the correct answer. Make your choice (1, 2, 3 or 4). Shade the oval (1, 2, 3 or 4) on the Optical Answer Sheet.

1 The value of the digit 4 in 75 481 is _____.

- (1) 40
- (2) 400
- (3) 4000
- (4) 40 000

()

2 Which number below is 100 less than 7548?

- (1) 6548
- (2) 7448
- (3) 7538
- (4) 7648

()

3 The figure shown is made up of identical triangles. What fraction of the figure is shaded?

- (1) $\frac{4}{5}$
- (2) $\frac{4}{8}$
- (3) $\frac{4}{9}$
- (4) $\frac{5}{9}$

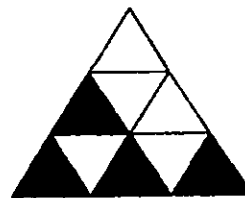

()

4 In the figure, which angle is greater than a right angle?

- (1) $\angle a$
- (2) $\angle b$
- (3) $\angle c$
- (4) $\angle d$

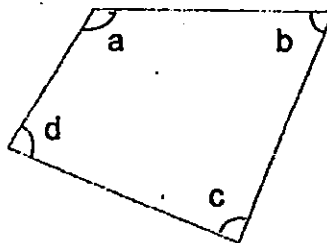

()

5 Express $\frac{47}{1000}$ as a decimal.

- (1) 0.047
- (2) 0.407
- (3) 0.47
- (4) 4.70

()

6 Which of the following mixed numbers is represented by the letter A in the number line shown?

- (1) $3\frac{1}{5}$
- (2) $3\frac{4}{5}$
- (3) $4\frac{1}{5}$
- (4) $4\frac{4}{5}$

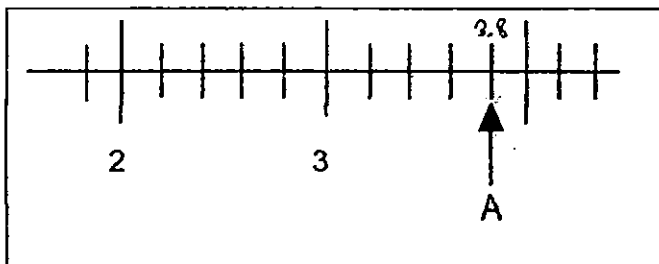

()

7 Ronald packed 2300 drumsticks into boxes. If each box can only contain 8 drumsticks, what is the minimum number of boxes required?

- (1) 275
- (2) 276
- (3) 287
- (4) 288

()

8 $\frac{5}{8}$ of a class are boys. There are 15 girls. How many boys are there?

- (1) 20
- (2) 24
- (3) 25
- (4) 40

()

9 In the figure below, which lines are horizontal?

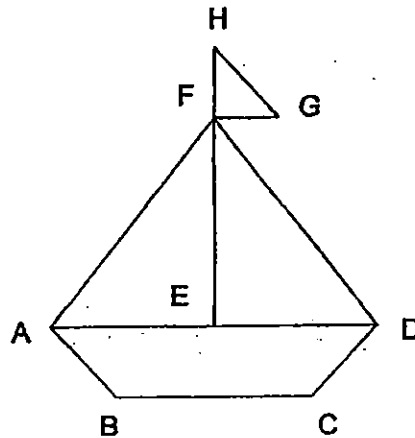

- (1) AB, DF, GH
- (2) AD and EH
- (3) AD, BC and FG
- (4) EF and FH

()

10 A wire is used to make a rectangle as shown below. If the same wire is used to make a square, what is the length of the square?

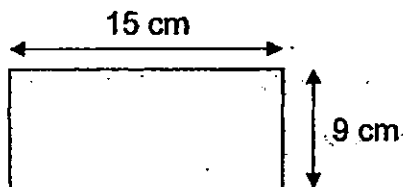

- (1) 6 cm
- (2) 12 cm
- (3) 24 cm
- (4) 48 cm

()

- 11 In the figure, PQRS is a square. $\angle TSR = 26^\circ$. Find angle $\angle x$.

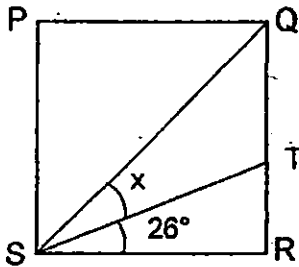

- (1) 19°
- (2) 29°
- (3) 38°
- (4) 54°

()

- 12 Round off 75.836 to the nearest tenth.

- (1) 76
- (2) 75.8
- (3) 75.84
- (4) 80

()

- 13 Shirley took the train at Lakeside station and reached City Hall station at 11.20 a.m. If her train journey took 33 minutes, what time did she board the train at Lakeside station?

- (1) 10.47 a.m.
- (2) 10.57 a.m.
- (3) 11.47 a.m.
- (4) 11.53 a.m.

()

- 14 The figure below is made of 2 identical rectangles of 11 cm by 6 cm. Find the perimeter of the following figure.

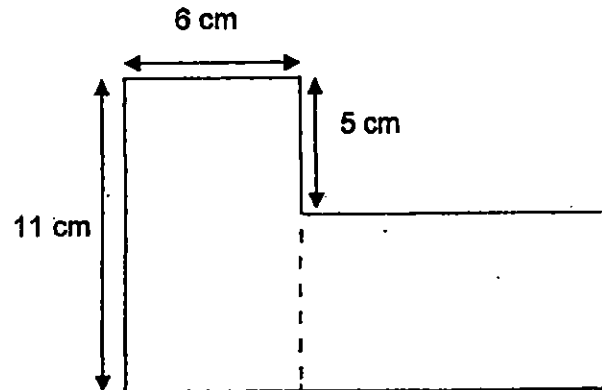

- (1) 50 cm
- (2) 56 cm
- (3) 68 cm
- (4) 132 cm

()

- 15 Sean has a piece of rectangular cardboard 20 cm by 9 cm as shown below. How many squares can he cut out, if each square has sides of 3 cm?

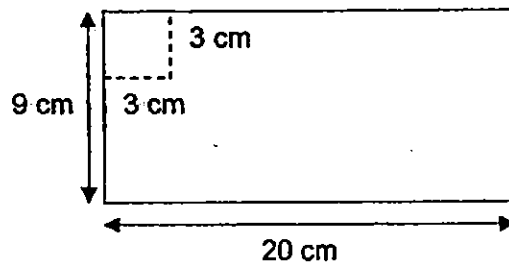

- (1) 18 squares
- (2) 20 squares
- (3) 21 squares
- (4) 60 squares

()

Use the information below to answer questions 16 and 17.

The line graph below shows the temperature of a cup of coffee over 7 minutes.

At the first minute, ice cubes were added to the coffee.

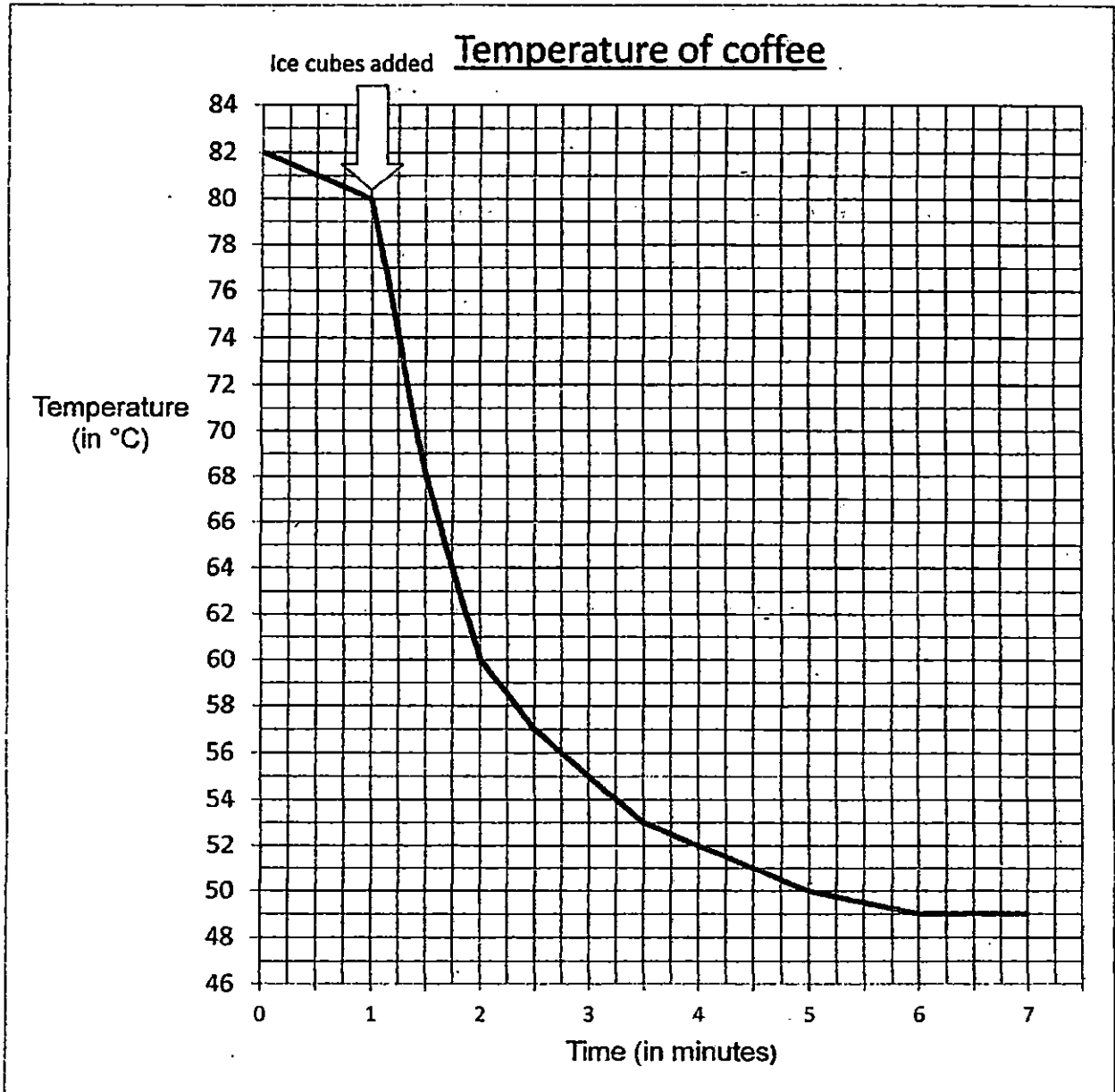

16 What was the temperature of the coffee after 2 minutes of adding ice cubes?

- (1) 54.5 °C
- (2) 55 °C
- (3) 60 °C
- (4) 80 °C

()

17 Between which one-minute interval did the temperature drop by 2°C only?

(1) 2nd and 3rd minute

(2) 3rd and 4th minute

(3) 4th and 5th minute

(4) 5th and 6th minute

()

18 Which of the following shapes do not tessellate?

(1)

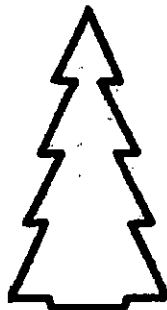

(2)

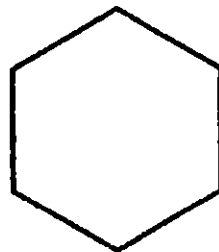

(3)

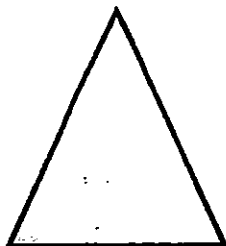

(4)

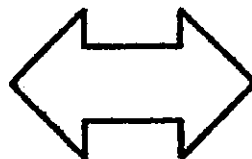

()

19 Which one of these letters has no line of symmetry?

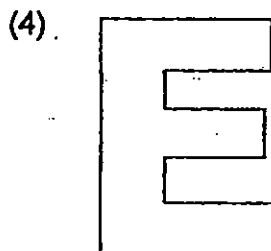
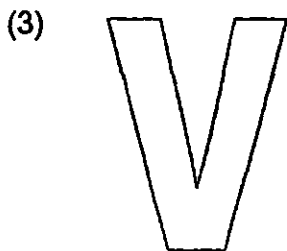
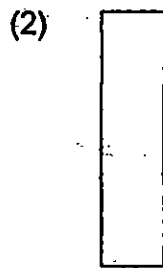
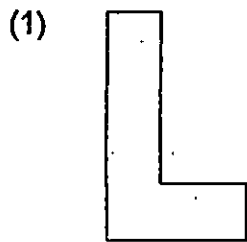

()

20 How many more squares should be shaded so that the dotted line AB is the line of symmetry of the figure below?

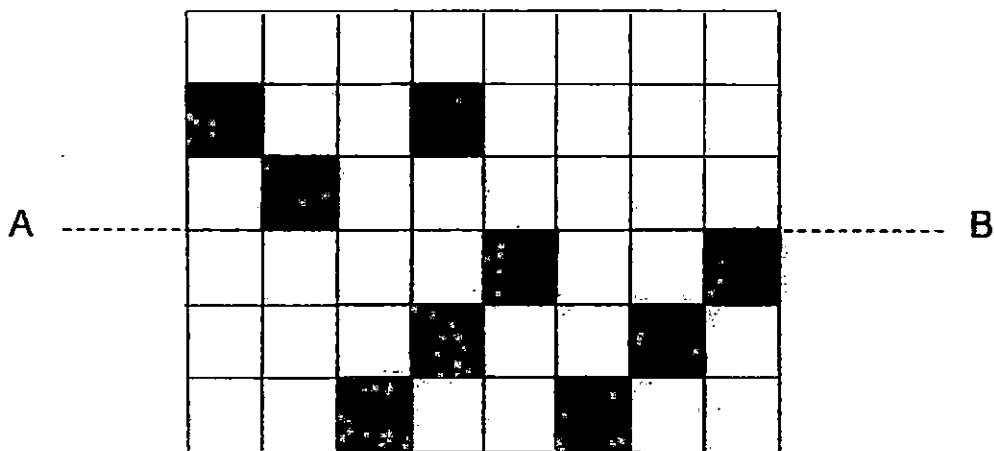

- (1) 5
- (2) 6
- (3) 7
- (4) 8

()

Section B (20 × 2 = 40 marks)

Write your answers in the answer blanks provided.

For questions that require working, show your working clearly in the space provided.

21 Write twelve thousand and seventy-five in figures.

Ans: _____

22 Some factors of 100 are 1, 2, 4, 5, 20, 50 and 100.

What are the other 2 factors of 100?

Ans: _____ and _____

23 Find the value of $5628 \div 7$.

Ans: _____

24 $5\frac{1}{9} = \frac{\boxed{?}}{9}$

What is the missing number in the box?

Ans: _____

25 What is the value of $\frac{5}{8} + \frac{3}{4}$?

Express your answer as a mixed number.

Ans: _____

26 Arrange the following numbers in order from the greatest to the smallest.

0.065, 0.506, $\frac{3}{5}$

Ans: _____
(greatest) (smallest)

27 Find the value of 5.64×7 .

Ans: _____

28 Find the value of $6.16 - 1.43$.

Ans: _____

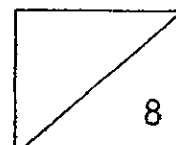

29 Measure and write down the size of $\angle x$.

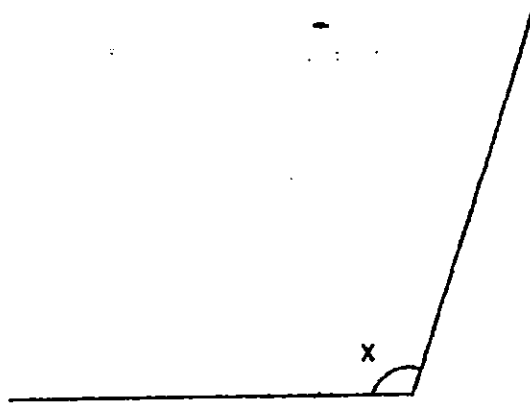

Ans: _____

30 Draw and label line CD, perpendicular to line AB.

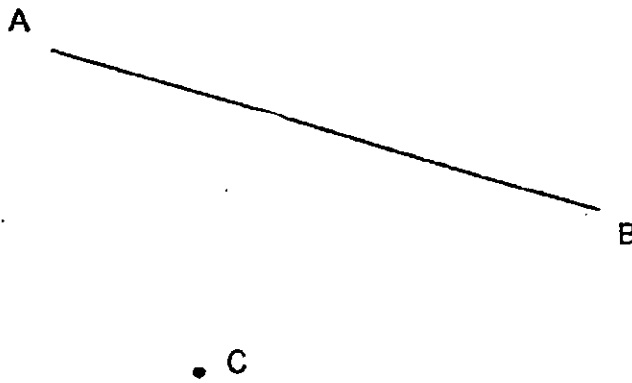

31 Draw and label a line 8 cm long, parallel to line EF through point G.

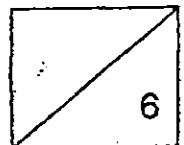
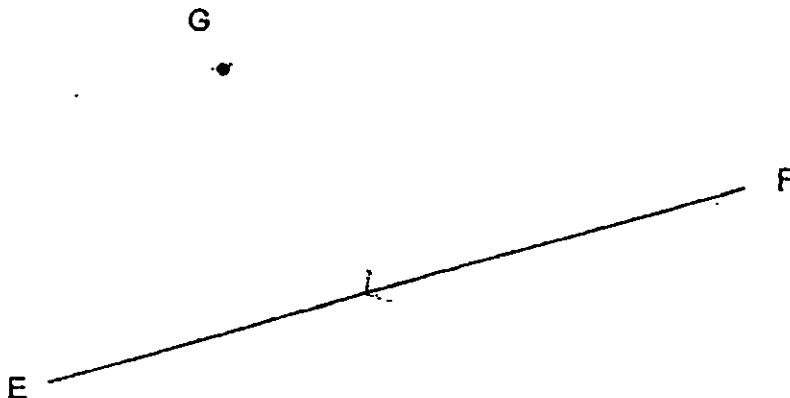

Q32. The figure below is made of a square and an equilateral triangle. If the area of the square is 64cm^2 find the perimeter of the figure.

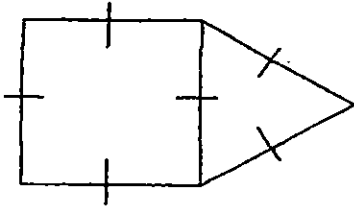

Q33. The picture frame below has a wooden border of 2cm. Find the area of the border.

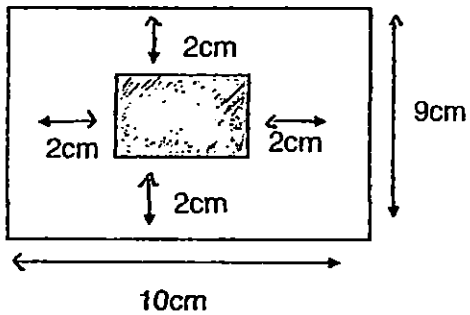

Q34. A rectangle has a perimeter of 2.4m. If its length is thrice as long as its breadth, Find the breadth of the rectangle.

35 Write the missing number in the number pattern below.

4, 9, 16, 25, 36, ?, ?, 81, 100, 121, 144

Ans: _____ and _____

36 Razak started doing his homework at 08 15. He then spent the same amount of time reading. He finished reading at 09 55. How many minutes did he spend on his homework?

Ans: _____ min

37 Complete the symmetric figure with line AB as the line of symmetry.

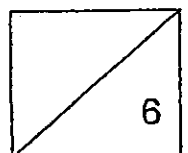
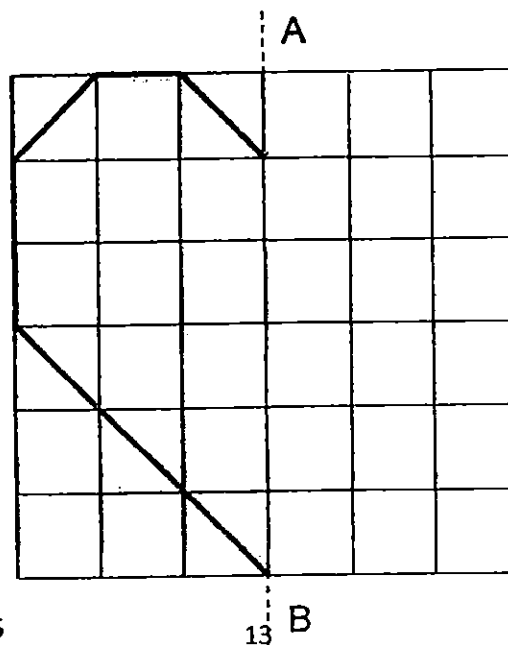

- 38 The pattern below shows part of a tessellation. Draw 2 more unit shapes to extend the tessellation in the space provided.

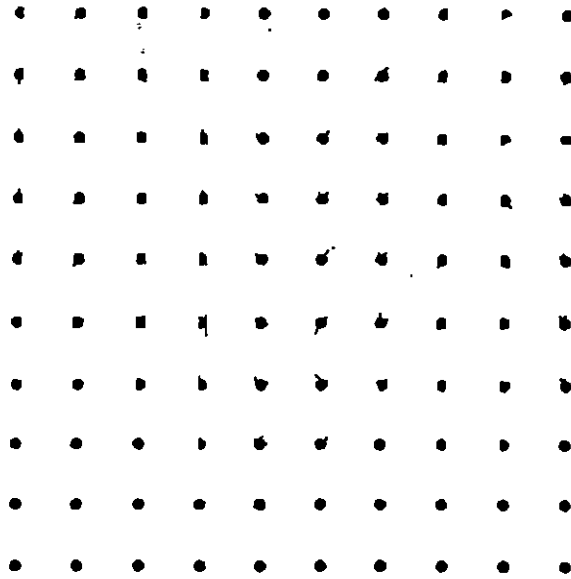

- 39 Refer to the square grid and fill in the blanks with A, B, C, D, E or F.

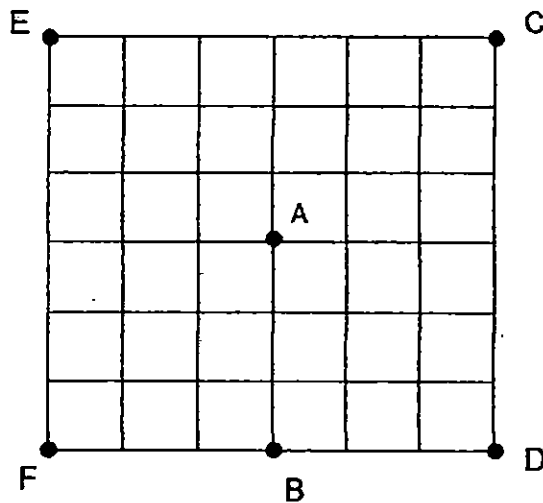

- a) Point A is north-west of Point ____.
 b) Point ____ is west of Point B.

Ans: a) _____

b) _____

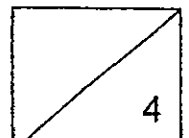

40 The line graph below shows Jacob's mass over a period of 6 years.

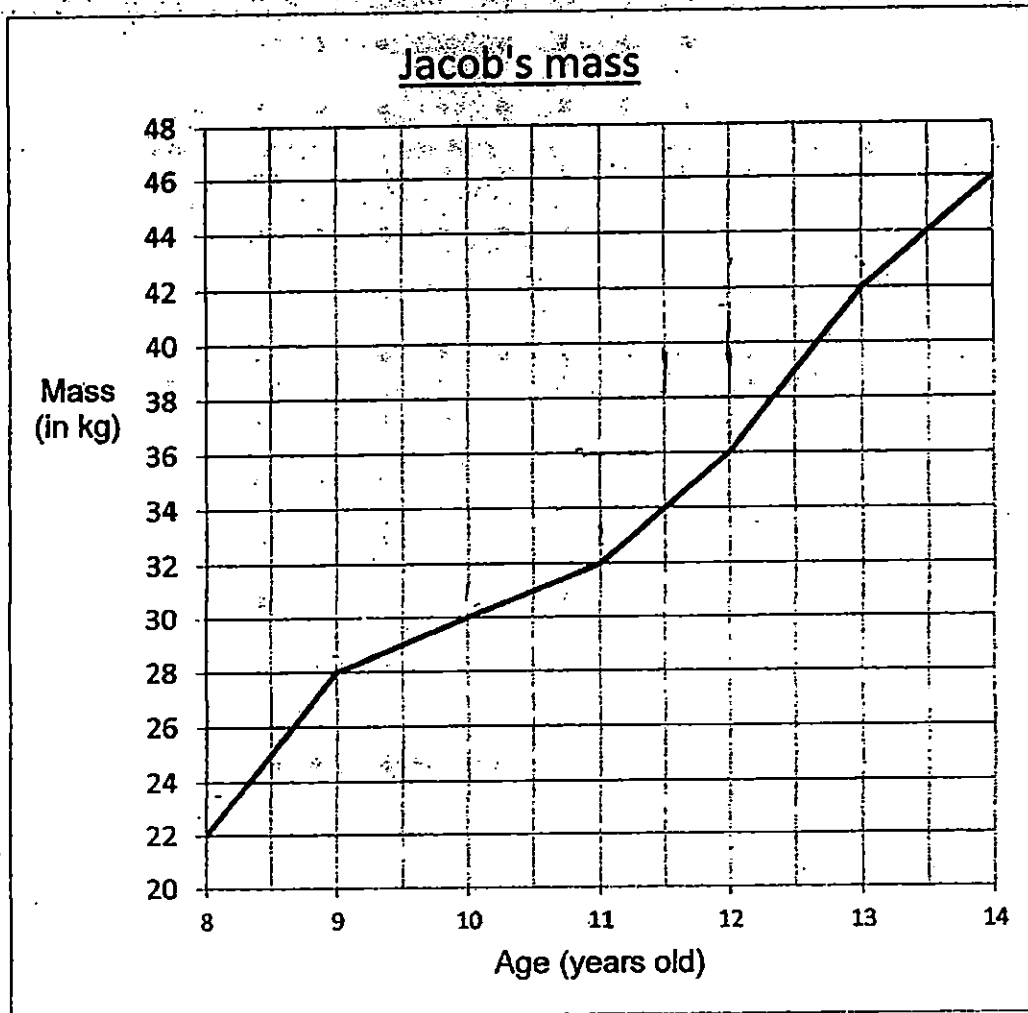

Use the line graph above to fill in the table below.

Age (years old)	8	9	10	11	12	13	14
Mass (in kg)	22		30	32		42	46

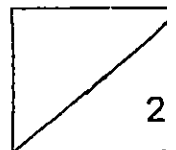

Section C (5 × 4 = 20 marks)

Solve each of the following problems. Show all your working and statements clearly. Write your answers in the spaces provided.

- 41 Alex had four times as many erasers as Bernard. If Alex gave 66 erasers to Bernard, they would have the same number of erasers. How many erasers did they have in all?

Working

Ans: _____

- 42 Auntie Bao has some apples. If she gives 8 apples to her children, she would have 3 extra. If she gives 9 apples to her children, she would be short of 2 apples. How many apples does she have?

Ans: _____

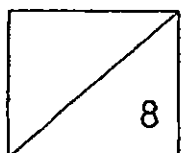

- 43 The table below shows the regular price and sale price of 3 items.

Working

Item	Regular Price	Sale Price
Soccer Ball	\$23	\$17
Tennis Racquet	\$48	\$34.95
Frisbee	\$12.50	\$7.95

During a sale, Jackson bought some soccer balls and 2 tennis racquets. If he saved \$44.10, how many soccer balls did he buy?

Ans: _____

- 44 The mass of a packet of rice was 5 kg. Geraldine used 1.4 kg on the first week, 1.23 kg on the second week and some on the third week. If the mass of the packet of rice at the end of third week was 0.6 kg, how many kilograms of rice did she use on the third week?

Ans: _____

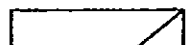

45 At the bus interchange, a number of people boarded the bus. At the first stop, $\frac{1}{4}$ of the passengers got off and 3 people boarded the bus. At the second stop, $\frac{1}{3}$ of the passengers got off and 13 people boarded the bus. If there were 33 passengers left on the bus, how many people boarded the bus at the interchange?

Working

Ans: _____

- End of Paper -

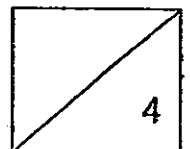



EXAM PAPER 2015

LEVEL : PRIMARY 4

SCHOOL : PEI HWA PRESBYTERIAN PRIMARY SCHOOL

SUBJECT : MATHEMATICS

TERM : SA2

Q1	Q2	Q3	Q4	Q5	Q6	Q7	Q8	Q9	Q10
2	2	3	1	1	2	4	3	3	2
Q11	Q12	Q13	Q14	Q15	Q16	Q17	Q18	Q19	Q20
1	2	1	2	1	2	3	4	1	3

Q21. $120\overline{)75}$

Q22. 25 and 10

Q23. 804

Q24. 46

Q25. $1\frac{3}{8}$

Q26. $\frac{3}{5}$ (greatest), 0.506, 0.065 (smallest)

Q27. $39.48 \rightarrow 5.64 \times 7 = 39.48$

Q28. 4.73

Q29. 108°

Q30. SEE PICTURE

Q31. SEE PICTURE

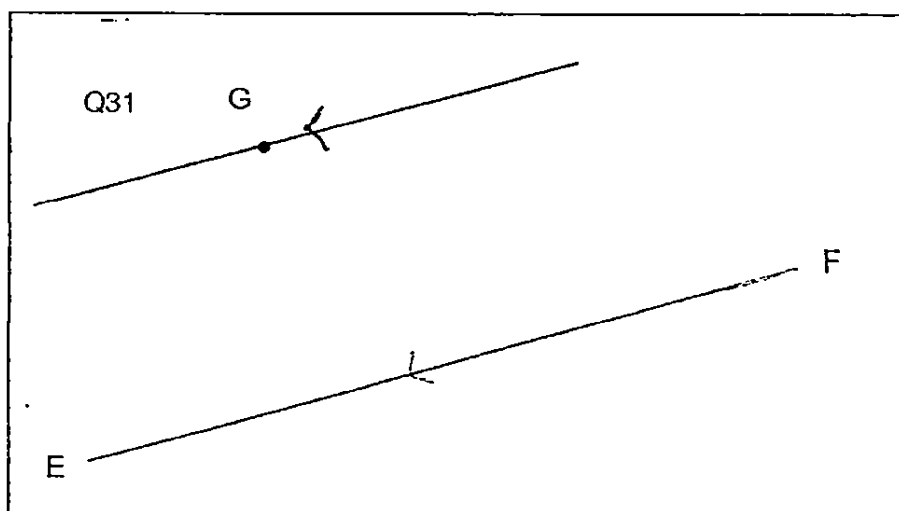
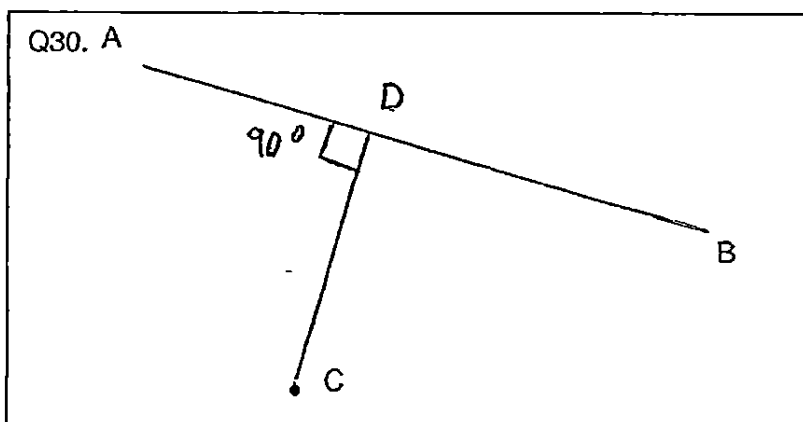

Q32. $40\text{cm} \rightarrow 8 \times 5 = 40$

Q33. $60\text{cm}^2 \rightarrow 10 \times 9 = 90, 10 - 4 = 6, 9 - 4 = 5, 6 \times 5 = 30, 90 - 30 = 60$

Q34. $0.3\text{m} \rightarrow 8 \text{u } 2.4, 1 \text{u } 2.4 \div 8 = 0.3$

