

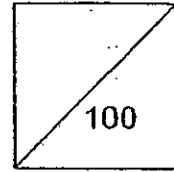

HENRY PARK PRIMARY SCHOOL
2010 SEMESTRAL EXAMINATION 1
SCIENCE
PRIMARY 4

Duration of Paper: 1 h 45 min



Name: _____ ()

Parent's Signature _____

Class: Pr 4 _____

Booklet A (60 marks)

For each question from 1 to 30, four options are given. One of them is the correct answer. Make your choice (1,2, 3 or 4). Shade the correct oval (1,2,3 or 4) on the **Optical Answer Sheet**.

1. Water and nitrogen are matter because they _____.

- A: have mass
- B: occupy space
- C: have no definite shape
- D: cannot be compressed

- (1) A and B only
- (2) C and D only
- (3) A, B and C only
- (4) B, C and D only

()



2. The tube shown below contains toothpaste.

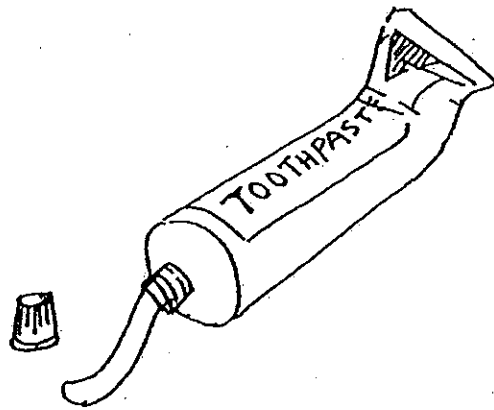

Which of the following statements about the toothpaste is/are correct?

A: It has volume

B: It takes the shape of its container

C: It can be compressed

(1) A only

(2) A and B only

(3) B and C only

(4) A, B and C

()

3. The table below shows the properties of solids, liquids and gases.

Properties	P	Q	R	S
Has a definite shape	✓			✓
Has mass	✓	✓	✓	✓
Can be compressed	✓	✓		
Can occupy space	✓	✓	✓	✓

Which one of the columns, P, Q, R or S, indicates the properties of an ice cube?

(1) P

(2) Q

(3) R

(4) S

()

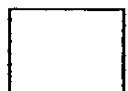

4. Study the diagram shown below.

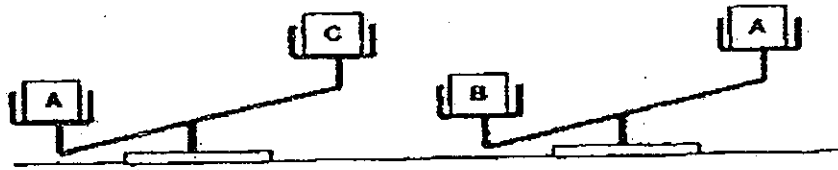

Arrange the objects A, B and C from the smallest to the greatest mass.

- (1) A, B, C
- (2) B, A, C
- (3) C, B, A
- (4) C, A, B

()

5. Alice used two identical syringes. Each syringe was covered with black paper and completely filled with either air or water.

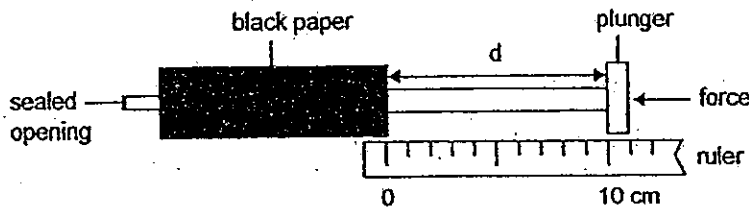

She sealed the opening of the syringe and then pushed each plunger as hard as she could. She then measured the distance, d . Which one of the following shows the correct values of d ?

	d (cm)	
	Syringe with air	Syringe with water
(1)	0	10
(2)	10	0
(3)	6	10
(4)	10	6

()

6. Peter wanted to find out whether a cube of sugar dissolves faster in hot or cold water. Which one of the variables below will have the least effect on his investigation?

- (1) The amount of water used
- (2) The kind of container used
- (3) The amount of sugar used
- (4) The temperature of the water

()

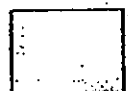

7. Danny wanted to cook some potatoes. He noticed that when he put the potatoes into the boiling water, the boiling stopped almost immediately for a short while as shown below.

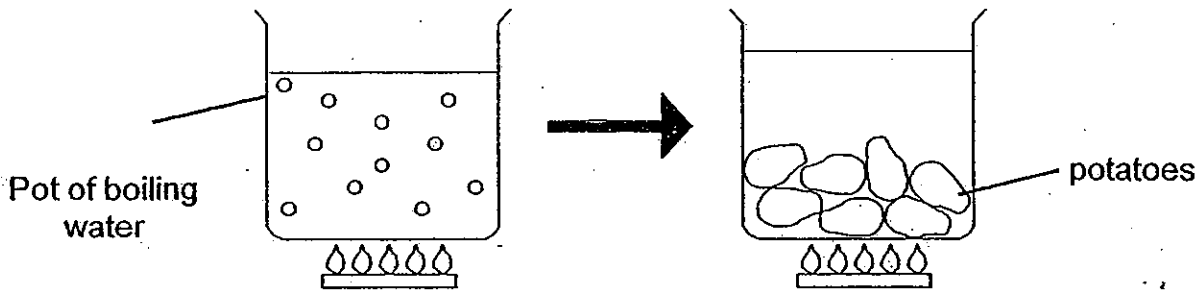

Why did the water stop boiling for a short while when the potatoes are put into it?

- (1) The boiling water lost heat to the potatoes.
- (2) The boiling water had increased its volume.
- (3) The potatoes prevented heat from travelling to the water.
- (4) The potatoes lost its coldness to the water so that boiling would stop. ()

8. 4 beakers of water are heated up over the same period of time as shown below.

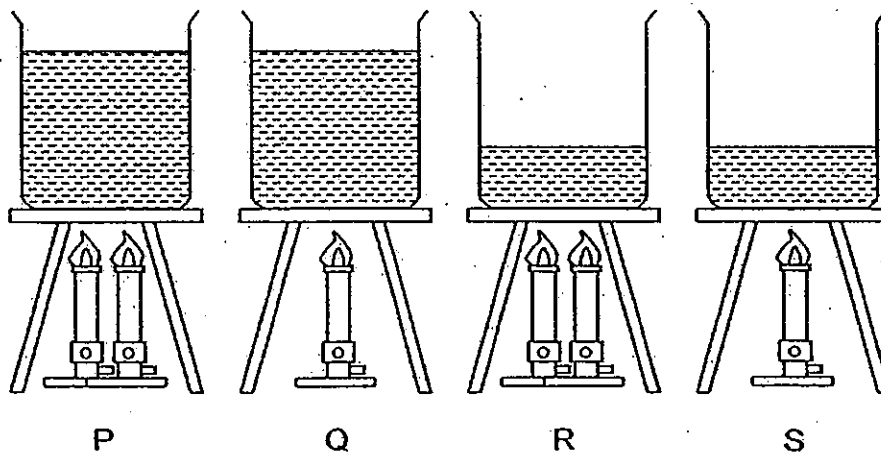

Which beaker of water will have the lowest temperature?

- (1) P
- (2) Q
- (3) R
- (4) S ()



9. David placed a deflated balloon over the opening of a flask as shown below.

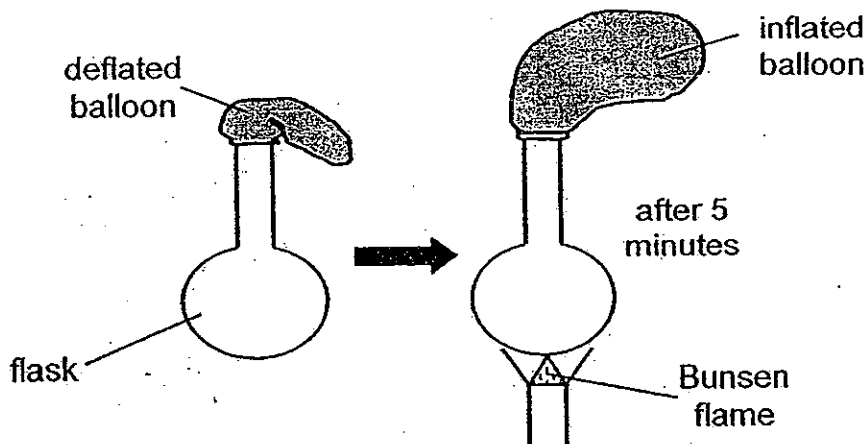

He then heated the flask with a Bunsen flame and he noticed that the balloon he placed over the opening of the flask had become inflated.

Which one of the following explains David's observations?

(1)	The air in the flask gains heat and expands, causing the balloon to inflate.
(2)	The air in the flask loses heat and contracts, causing the balloon to inflate.
(3)	The flask gains heat and expands, causing the balloon to inflate.
(4)	The flask loses heat and contracts, causing the balloon to inflate.

()

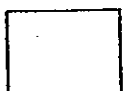

10. Linda placed a huge block of ice on a metal plate at A as shown in the diagram below.

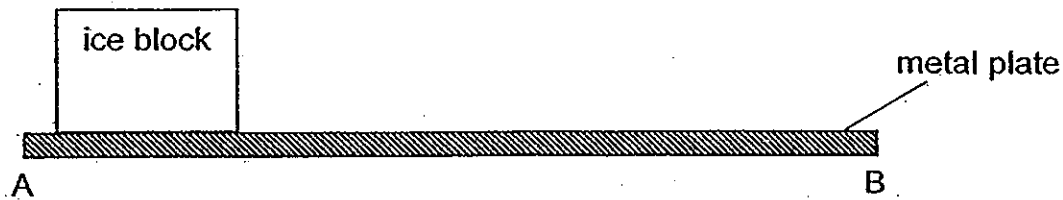

After some time, Linda saw that the block of ice was melting and felt that the metal plate at B was cold.

Which one of the following explains correctly Linda's observations?

	ice block	metal plate
(1)	gained heat from the metal plate	lost its heat to the ice block
(2)	gained heat from the metal plate	gained coldness from the ice block
(3)	lost heat to its surroundings	gained coldness from the ice block
(4)	lost heat to its surroundings	gained heat from its surroundings

()

11. Kenneth wants to find out if white or black paper cups absorb heat faster. The cups below contain water of the same temperature.

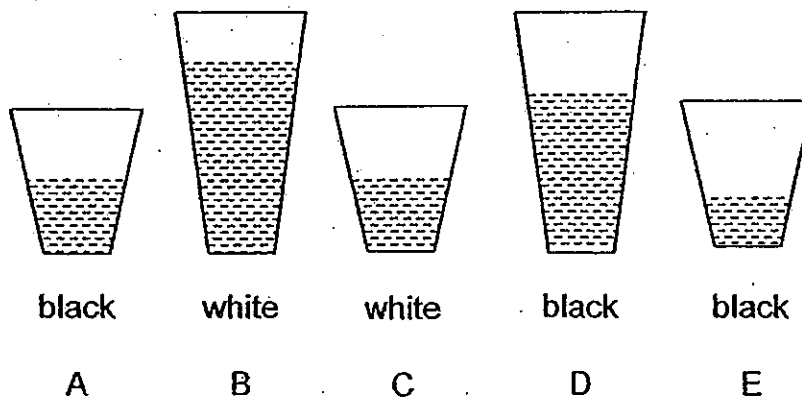

Which one of the following pairs of cups should he use to ensure a fair test?

- (1) B and D only
- (2) C and E only
- (3) A and C only
- (4) D and E only

()

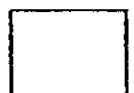

12. A thermometer was placed in each of the set-ups, A and B, as shown in the diagram below. Each beaker was covered and contained equal amounts of tap water. Set-up A was left in the classroom and Set-up B was left in the garden under the hot sun. At the start of the experiment, the temperature of the tap water was recorded as 28°C.

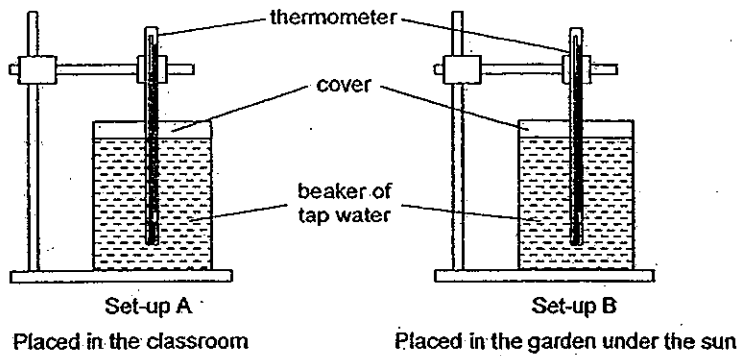

The readings of the two thermometers were recorded at regular intervals and presented in a line graph. Which one of the following graphs correctly represents the possible temperature changes of the tap water in both set-ups over a period of 3 hours?

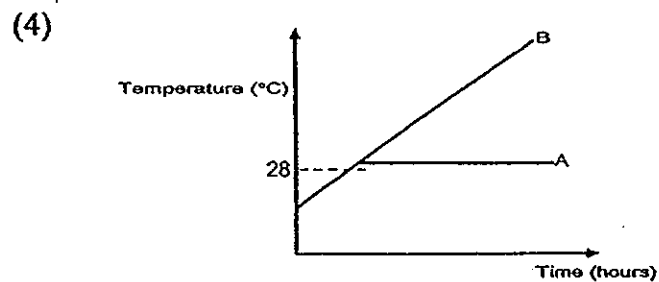
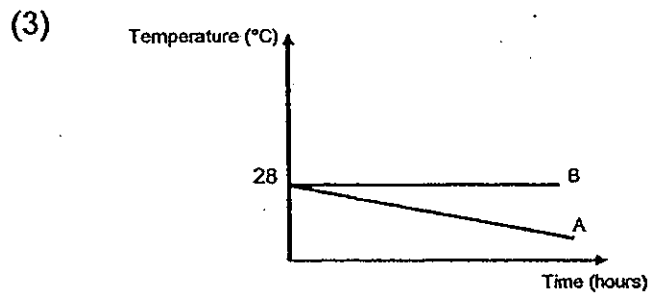
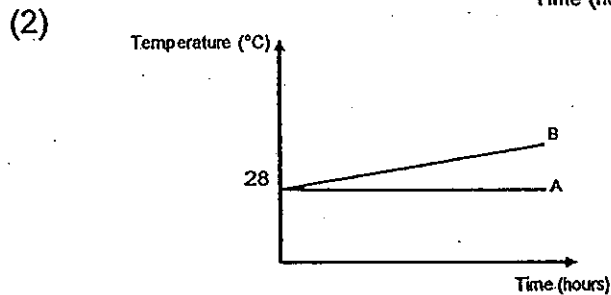
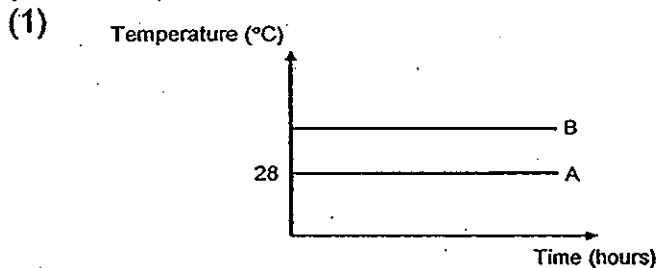

()

13. Study the diagram below carefully.

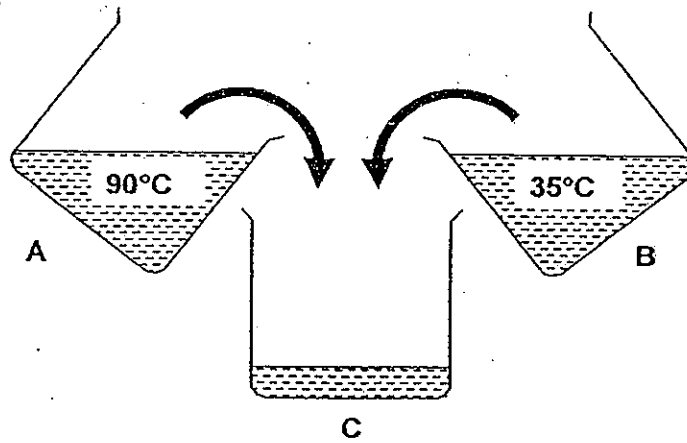

Janice poured the liquids from Beakers A and B into Beaker C. Which of the following will most likely be the temperature of the liquid in Beaker C?

- (1) 25°C
- (2) 40°C
- (3) 90°C
- (4) 125°C

()

14. Priyanka was given 4 different thermometers to use to measure the temperature of a liquid shown below:

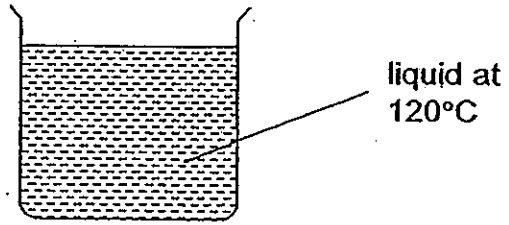

The temperature range of each thermometer is shown below.

Thermometer	Temperature range
A	0°C – 50°C
B	30°C – 45°C
C	20°C – 90°C
D	85°C – 130°C

Which thermometer should she use?

- (1) A
- (2) B
- (3) C
- (4) D

()



15. Study the diagram below carefully. A piece of metal wire was stretched tight by a metal weight. A candle was lit at the position shown in the diagram for some time.

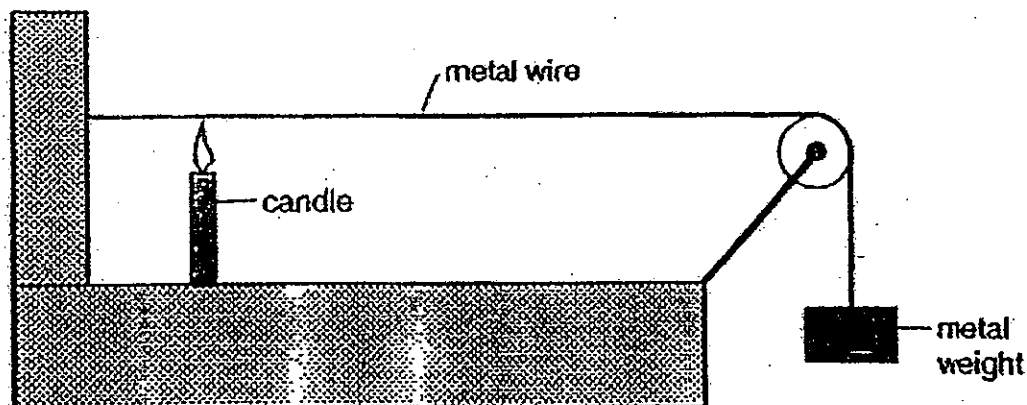

What happened to the metal weight after the wire was heated for some time?

- (1) It became lighter
- (2) It remained unchanged
- (3) It moved slightly upwards
- (4) It moved slightly downwards

()

16. Which of the following statement(s) about energy is/are true?

A: Energy is the ability to do work.
B: The Sun is our main source of energy.
C: Cold objects do not have heat energy.

- (1) B only
- (2) C only
- (3) A and B only
- (4) A, B and C

()

17. Which of the following is a source of light?

A: Sun
B: Moon
C: Mirror
D: Television

- (1) A only
- (2) A and D only
- (3) B and C only
- (4) A, B and D only

()



18. Sally is reading a book with the help of her desk lamp.



Which one of the following explains why Sally is able to read?

- (1) The book absorbs light from the lamp.
- (2) The book gives out light which enters her eyes.
- (3) Her eyes give out light which enables her to see.
- (4) The book reflects light from the lamp into her eyes.

()

19. Shauna's teacher set up the experiment as shown below.

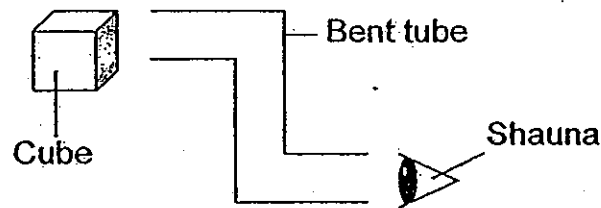

Her teacher gave her 2 mirrors and asked her to place them in the bent tube so that she would be able to see the cube.

How should Shauna place the 2 mirrors?

<p>(1)</p>	<p>(3)</p>
<p>(2)</p>	<p>(4)</p>

()



20. Which one of the following shows correctly how light makes it possible for the girl to see the plant?

(1)

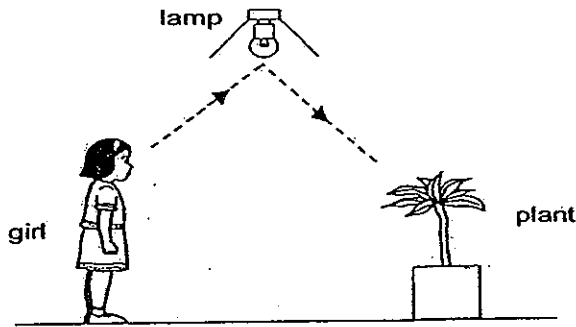

(2)

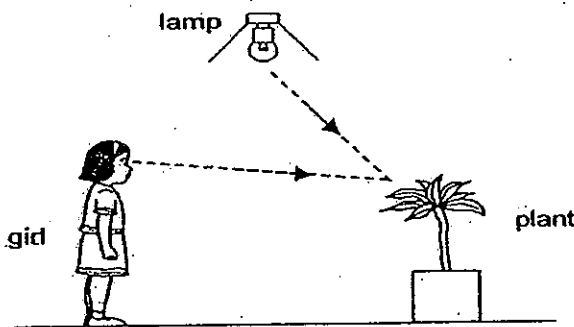

(3)

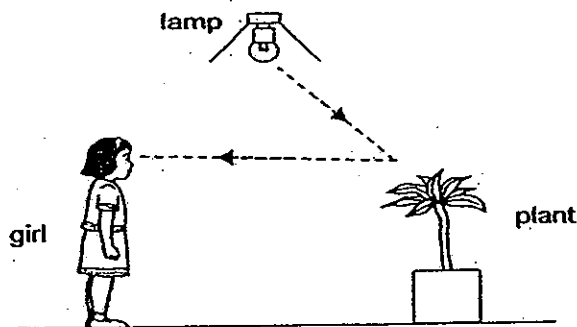

(4)

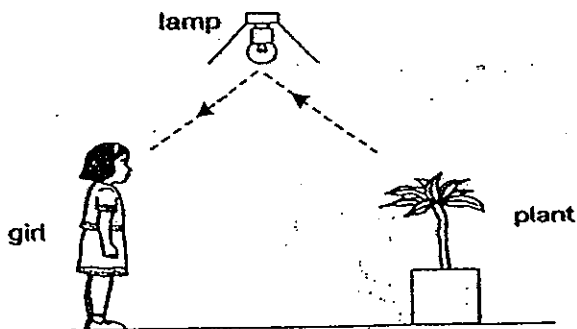

()



21. Connie placed a ball and a clear plastic sheet in a straight row. She shone a torch at them as shown below.

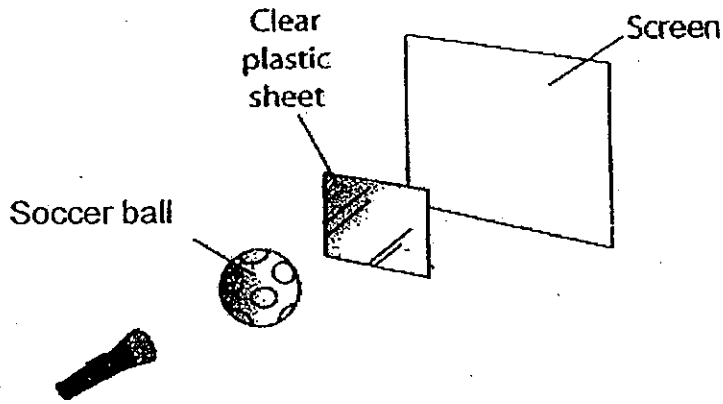

Which one of the following would Connie see on the screen?

(1)

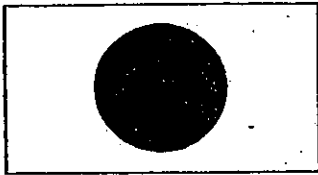

(3)

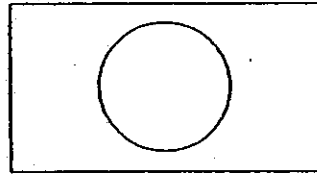

(2)



(4)

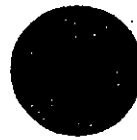

()



22. Dora set up the following experiment.

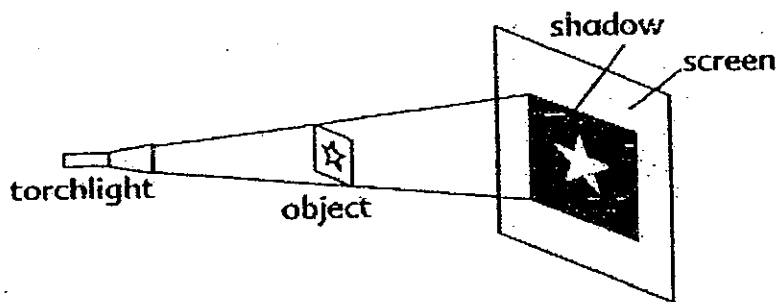

Dora then changed something in the experiment and the size of the shadow became bigger.

What did Dora change?

- (1) She used a stronger torchlight.
- (2) She moved the object closer to the screen.
- (3) She moved the object closer to the torchlight.
- (4) She moved the torchlight further away from the object.

()

23. Tracy placed 3 objects in a dark room as shown below.

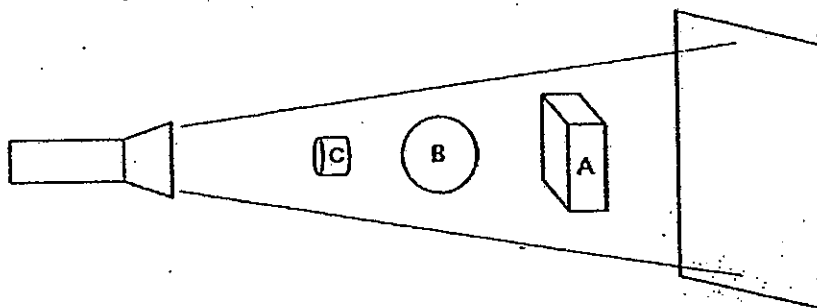

When she shone the torchlight on the objects, a shadow is cast on the screen as shown below.

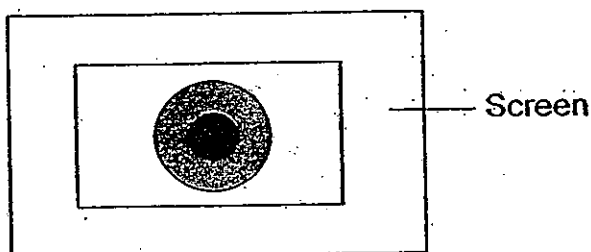

What materials can objects A, B and C be made of?

	Object A	Object B	Object C
(1)	Clear glass	Frosted plastic	Metal
(2)	Frosted plastic	Clear glass	Metal
(3)	Clear glass	Metal	Frosted plastic
(4)	Metal	Frosted plastic	Clear glass

()

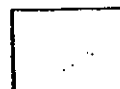

Jimmy wanted to find out what type of food Animal P ate. He placed Animal P in a cage with food and water and changed the type of food he gave Animal P at the start of every week. He then recorded the number of Animal P at the end of every week for 4 weeks.

He plotted his data into a bar graph.

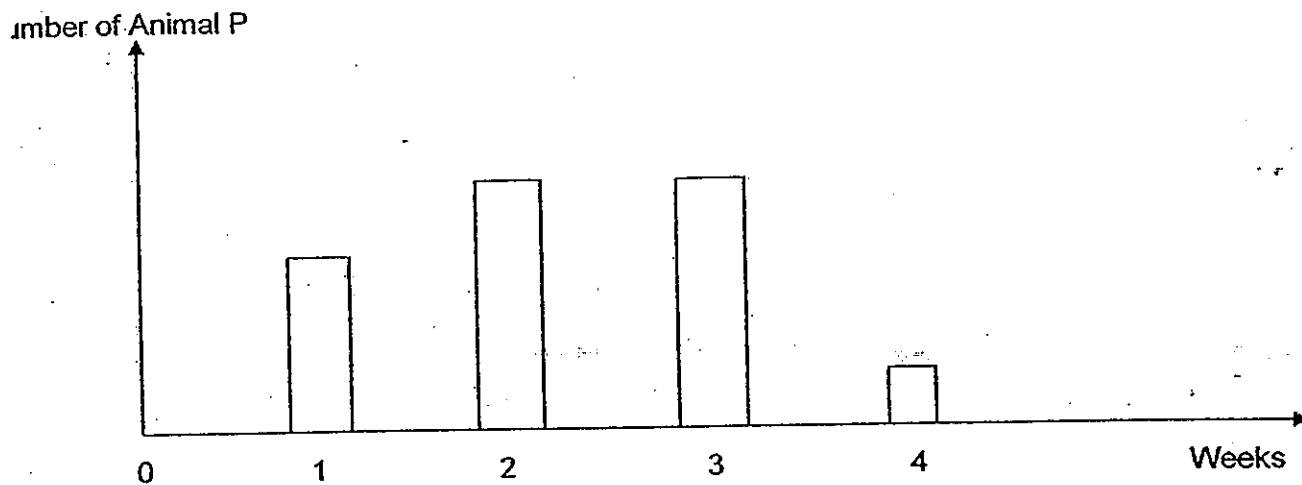

In which week, 1, 2, 3 or 4 did Jimmy give Animal P the wrong food?

- (1) Week 1
- (2) Week 2
- (3) Week 3
- (4) Week 4

()

i. Observe the following group of animals.

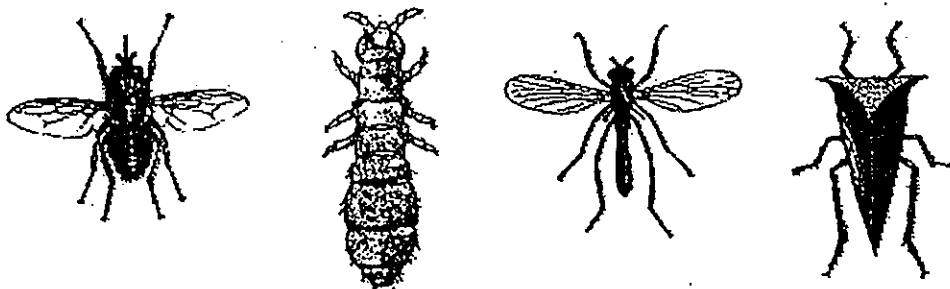

In what ways are these animals similar?

- (1) They have wings.
- (2) They have feelers.
- (3) They have six legs.
- (4) They have the same body shape.

()



26. Observe Animal K below.



Animal K

Which one of the following animals would most likely move in the same way as Animal K?

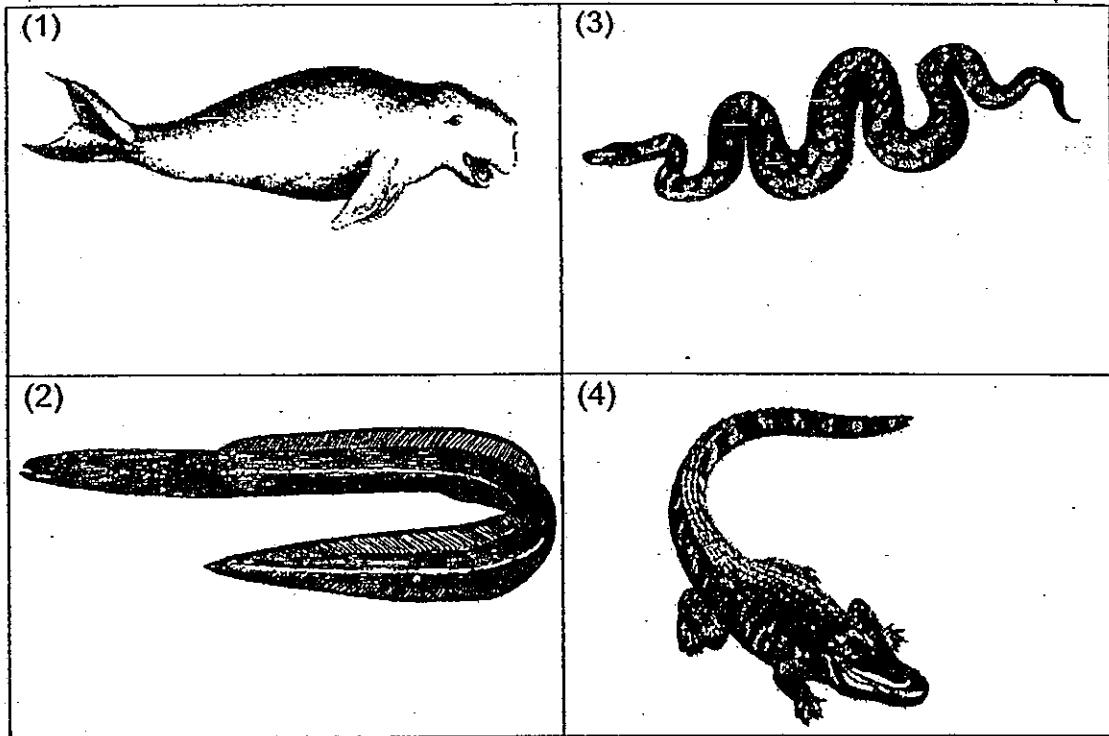

()

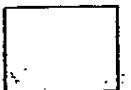

27. Caleb created a chart to describe Animals W, X, Y and Z as shown below.

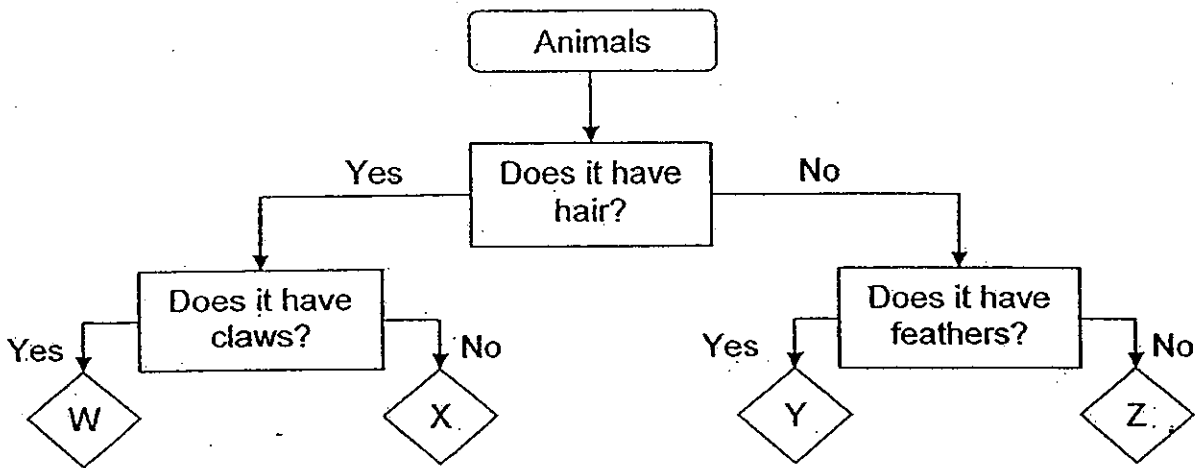

Which one of the following identifies Animal W, X, Y and Z correctly?

A: Animal W

C: Animal Y

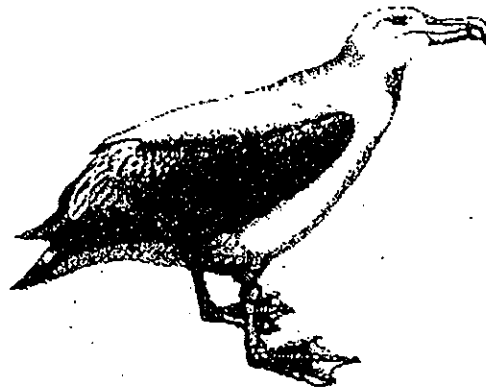
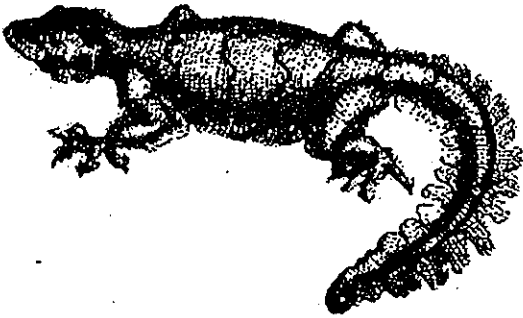

B: Animal X

D: Animal Z

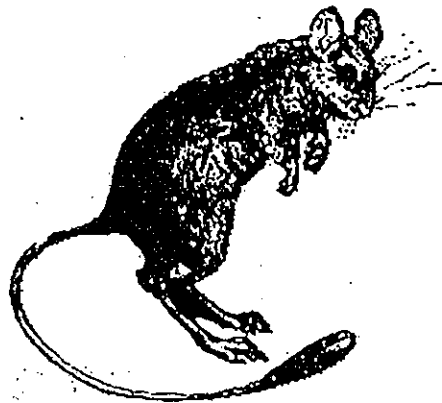

- (1) D only
- (2) A and D only
- (3) B and C only
- (4) A, B and C only

()

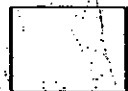

28. Kate wanted to grow some beans. She placed 3 beans in Bowl A and 8 beans in Bowl B.

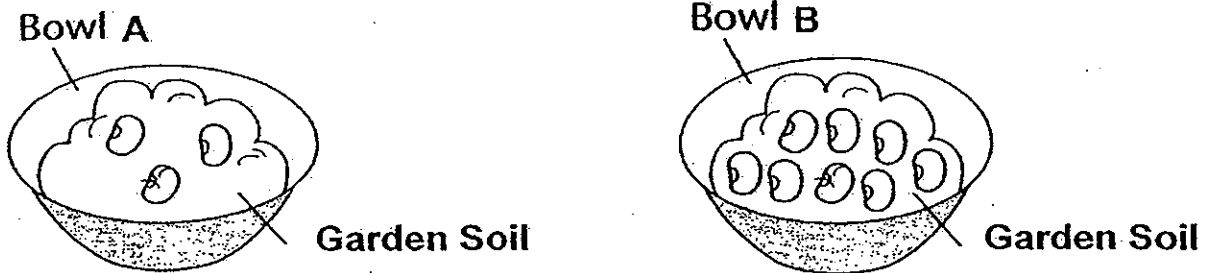

Kate watered them with the same amount of water every day and left them in the garden.

After 1 month, Kate observed that the beans in Bowl A have grown into plants with thicker and stronger stems than those in Bowl B.

Which of the following explains Kate's observation?

- A: Each bean in Bowl A received more air.
- B: Each bean in Bowl A received more water.
- C: Each bean in Bowl A received more nutrients from the soil.

- (1) A only
- (2) B only
- (3) A and C only
- (4) B and C only

()

29. Study the plants below.

Kugan crossed out one of the plants because it does not belong in the group.

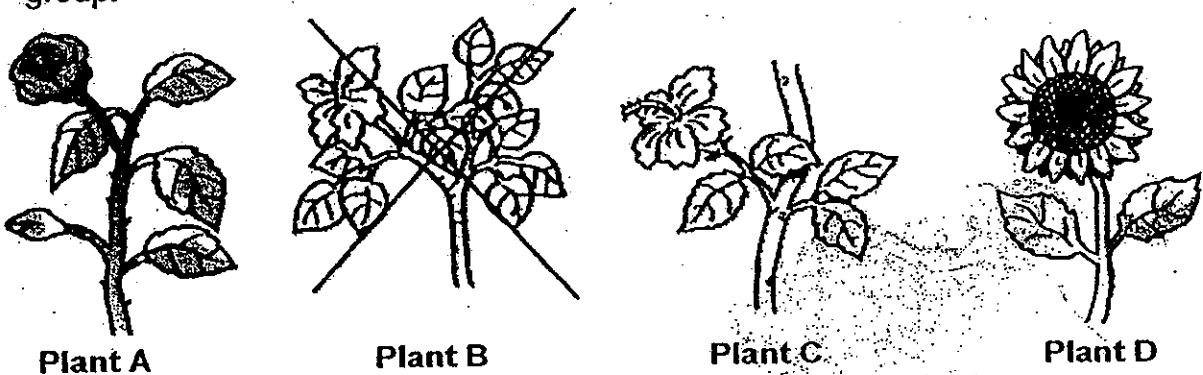

Which one of the following explains Kugan's observation?

- (1) Plant B has a different flower from the rest of the plants.
- (2) Plant B has leaves that are different from the rest of the plants.
- (3) Plant B has a different number of leaves from the rest of the plants.
- (4) Plant B has a flower that grows differently from the rest of the plants.

()



30. Observe the flow chart below.

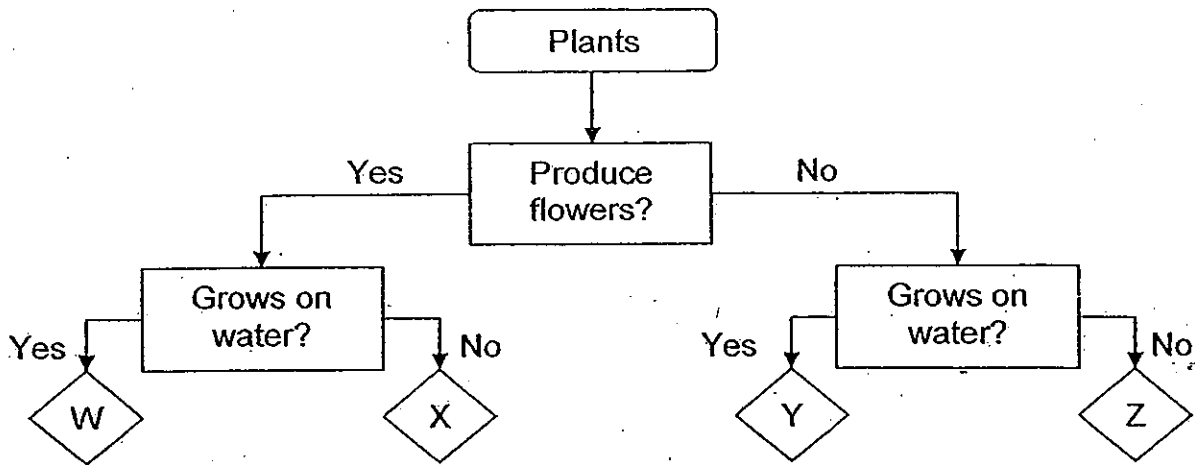

Which of the following statements are true?

- A: W reproduces from seeds.
- B: X is a type of fungi.
- C: Z reproduces from spores.

- (1) A only
- (2) B only
- (3) A and C only
- (4) B and C only

()

End of Booklet A

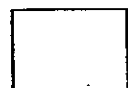

HENRY PARK PRIMARY SCHOOL
2010 SEMESTRAL EXAMINATION 1
SCIENCE
PRIMARY 4

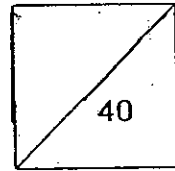

Name: _____ ()

Class: Pr 4 _____

Booklet B (40 marks)

Write your answers to questions 31 to 44 in the spaces given.

31. Casey was given the following set up. She was asked to push the inverted cup into the trough.

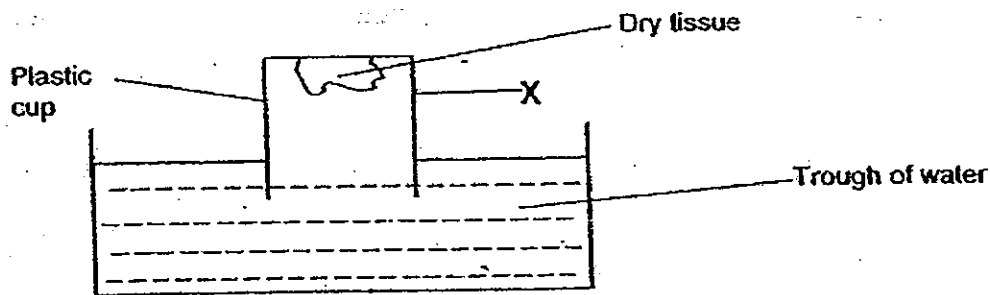

- a) Explain why the tissue remained dry when the plastic cup was pushed into the trough of water. (1m)

- b) A hole, the size of a 1-cent coin, is made at X. Casey then pushed the inverted cup into the trough again. (1m)

What observation about the tissue would Casey most likely make?

- c) Explain your answer in (b). (1m)



Study the flow chart below.

3m

a) Complete the flowchart by identifying the three states, solid, liquid and gas. (4m)

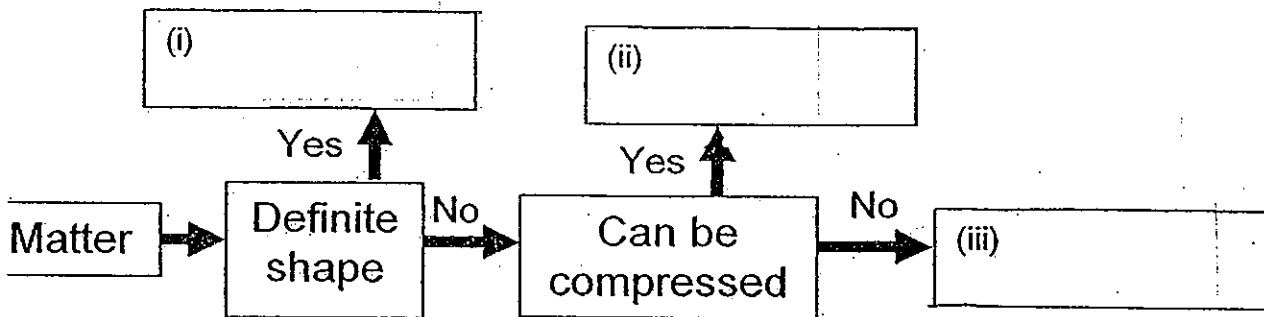

b) Jack observed that a sponge can become smaller when it is pressed. (1m)
He says a sponge is an example of (ii).

Is Jack correct? Explain.

c) Jane thinks that heat is not matter. Explain why she is correct. (1m)

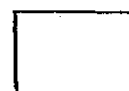

33. Mrs Lim wanted to make some ice-cream. She used the ice-cream maker shown in the diagram below.

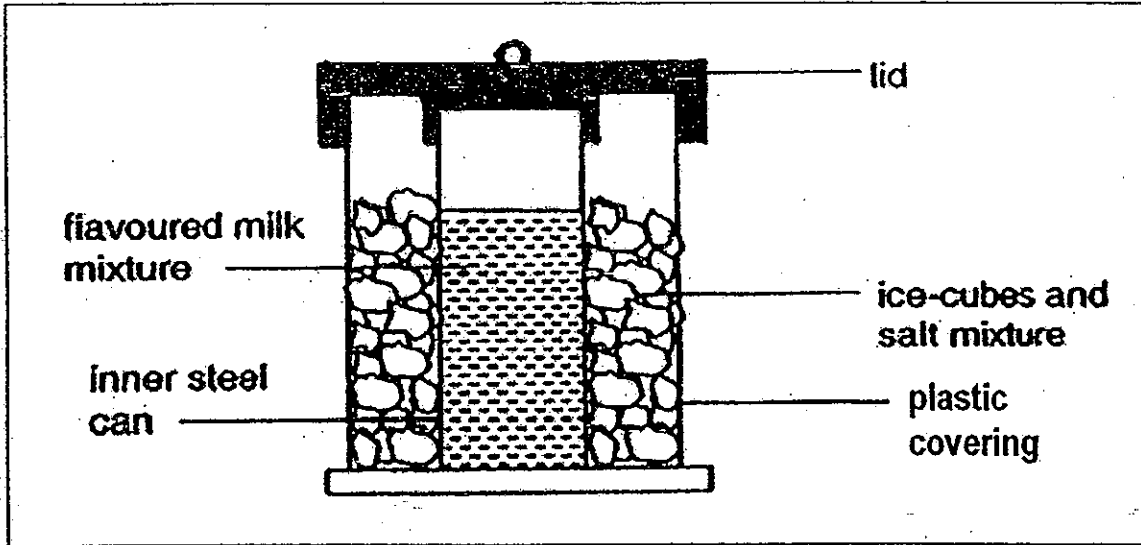

a) Explain how the flavoured milk mixture became ice-cream. (1m)

b) Why is the inner can made of steel and not plastic? (1m)

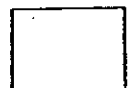

34. A Teh Tarik drink is actually hot tea pulled by successive pouring from one container to another and back as shown below.

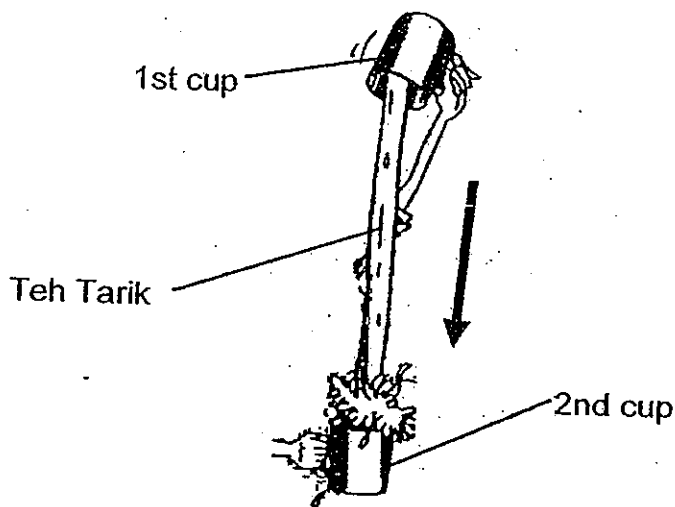

Bala measured the temperature of his Teh Tarik drink. He then poured the Teh Tarik into a second cup and then back to the first cup. He did this several times and then measured the temperature of the Teh Tarik drink in the second cup again.

	Temperature of Teh Tarik (°C)
1st cup	95
2nd cup	90

- a) Why did the temperature of the Teh Tarik drink drop when it was transferred several times from the first cup to the second cup? (1m)

- b) Bala then left the cup of Teh Tarik drink on the table in the Science Room. He measured the temperature of the Teh Tarik drink after 5 hours and found that it was 31°C. The temperature in the Science Room was 31°C. Explain what happened. (1m)



35. Nurul put an ice block of equal volume in each container for 30 minutes.

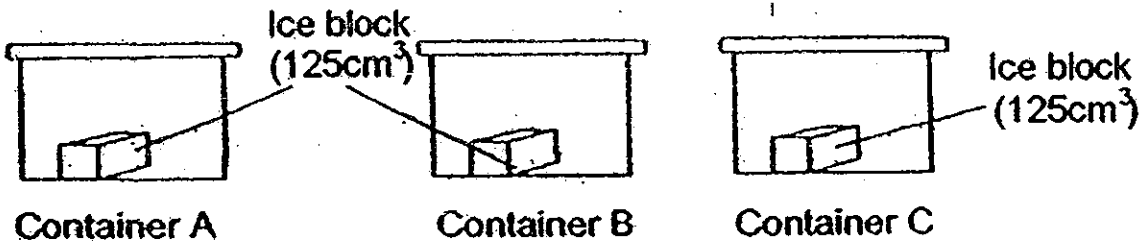

After 30 minutes, she noticed that part of the ice had melted in each container. She collected the water in each container and recorded her findings in a bar graph as shown below.

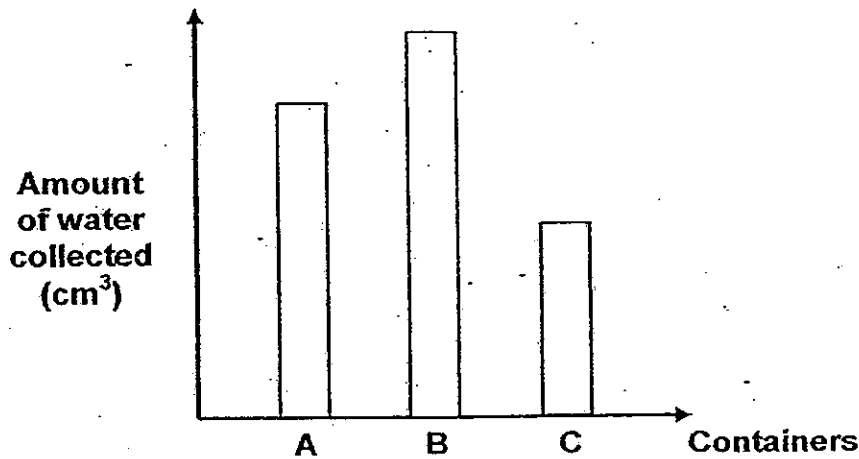

a) Nurul is going on a picnic. Which container should she use to keep her food warm? (1m)

b) Explain why she should choose the type of container in (a). (1m)

c) Suggest a material that the container in (a) can be made of. (1m)



36. Mrs Lim could not open the lid of her jam jar that she had just taken out of the refrigerator. She placed the jam jar into a basin of warm water as shown in the diagram below. After a short while, she took the jar out and was able to open the lid.

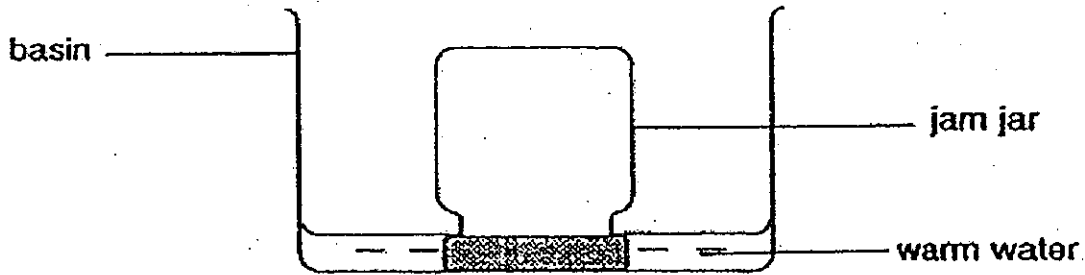

- a) Why was Mrs Lim able to open the lid after placing it in warm water? (1m)

- b) Two glasses are stuck together as shown below. (1m)

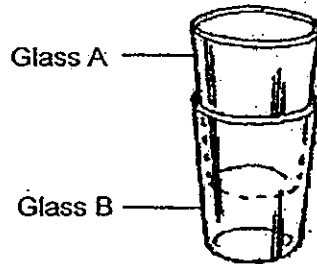

- i) No matter how hard Ken tried, he cannot separate them. Ken has some ice cubes with him. Describe how Ken can use the ice cubes to separate the glasses. (1m)

- ii) Explain how the ice enables Ken to separate the glass. (1m)

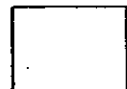

37. The diagram below shows a glass container containing hot lemon tea and ice cubes.

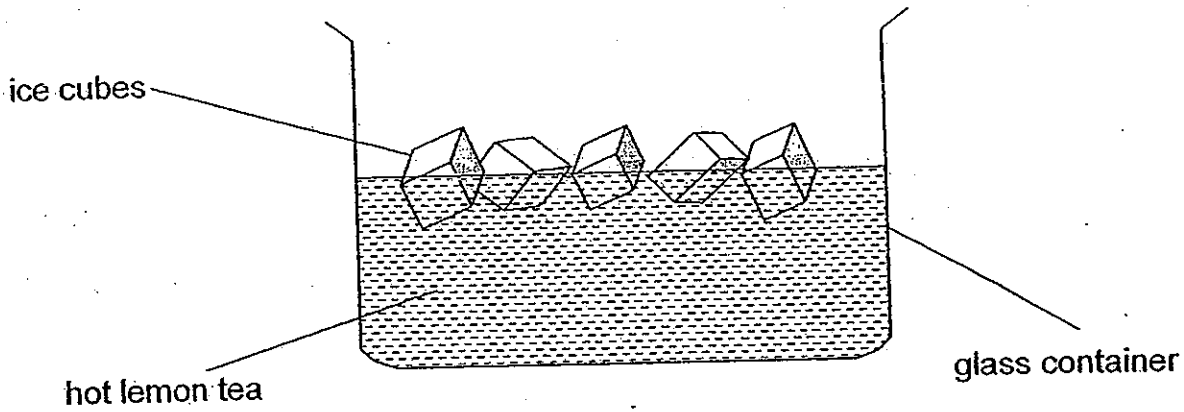

a) Put a tick (✓) in the correct box in the table below to indicate whether the object gained or lost heat. (1m)

	hot lemon tea	ice cubes
Gained Heat		
Lost Heat		

b) Explain what would happen to the ice cubes after 2 minutes. (1m)

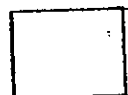

38. Reisha set up the experiment below to create shadows of Object P on 2 different screens as shown below.

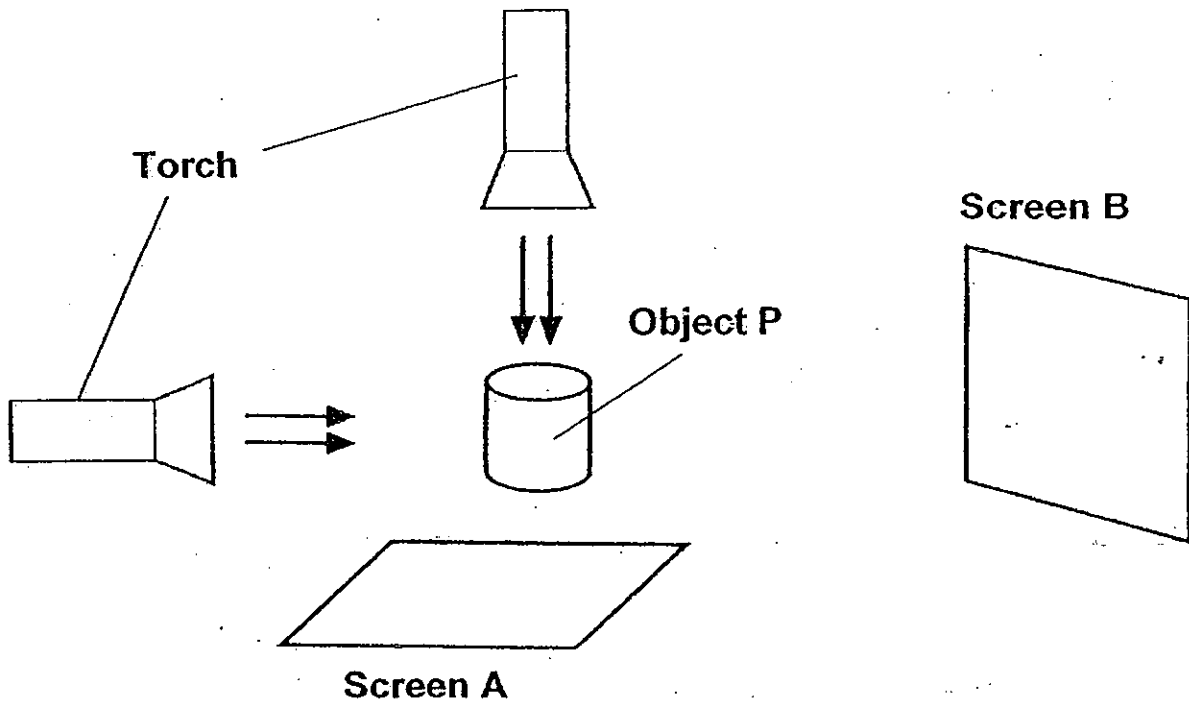

- a) In the space below, draw how the shadows of Object P will look like on Screen A and Screen B if Object P is opaque. (2m)

<p>Shadow on Screen A</p>	<p>Shadow on Screen B</p>
---------------------------	---------------------------

- b) Mark an 'X' on the picture above to show where Reisha can put Object P so that she will see a shadow of Object P on Screen B only. (1m)



9. Siti set up the experiment below to investigate how distance between the light source and the rubber toy (D) will affect the height of the shadow cast (H).

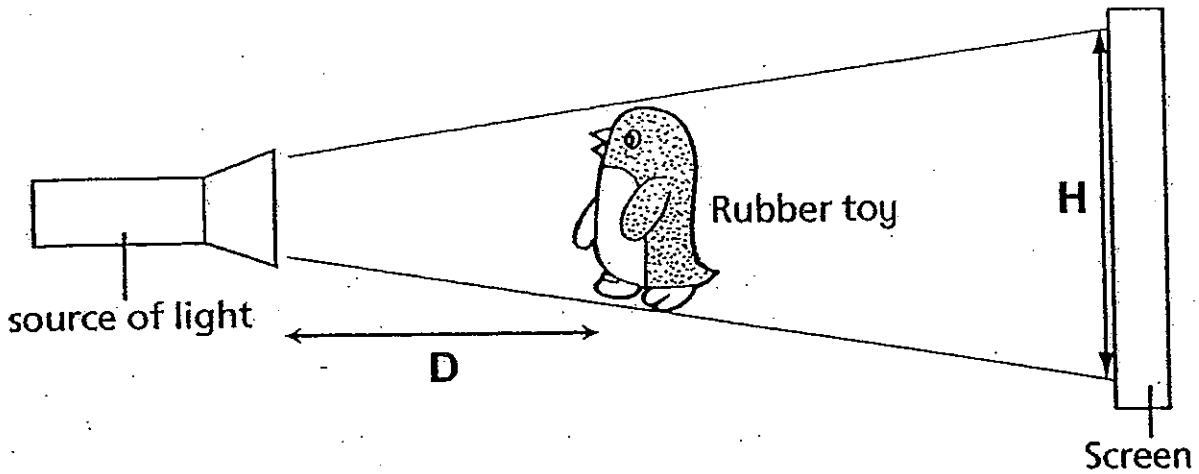

Siti changed the distance (D) a few times and recorded her results in a table as shown below.

Distance (D)	Height of shadow (H)
10 cm	56 cm
14 cm	52 cm
20 cm	Y

- a) Based on the experiment, what is a possible value for Y in the table above? (1m)

_____ cm

- b) What can Siti conclude from this experiment? (1m)

- c) What will happen to the size of the shadow if Siti moves the screen further away from the rubber toy? (1m)



40. Sarah used the setup below to investigate how much light passes through each type of liquid.

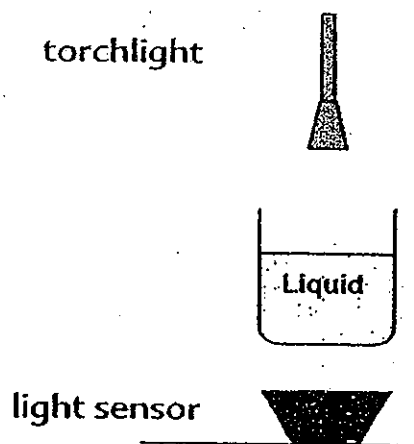

She used a light sensor to measure the light that passes through each liquid and recorded her results in a table below.

Liquid	Units of light
Coke	45
Tap water	210
Cooking oil	120
No liquid	?

- a) How many units of light will be measured when there is no liquid in the same container? (1m)

- b) Name 2 variables that Sarah must keep the same for a fair experiment. (2m)

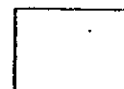

41. Scientists from Planet X recently discovered some new living creatures on their planet. They studied their characteristics and recorded them in the table below.

Creature	Lives near water	Lives in mountains	Plant-eater	Animal-eater
A	✓		✓	
B		✓	✓	
C		✓		✓
D	✓			✓
E		✓	✓	
F		✓		✓

- a) Fill in the headings in the classification table in boxes (ii), (iii), (iv) and (v). (2m)
- b) Using the characteristics above, classify Creatures A, B, C, D, E and F by filling the boxes. (2m)

The first box has been done for you.

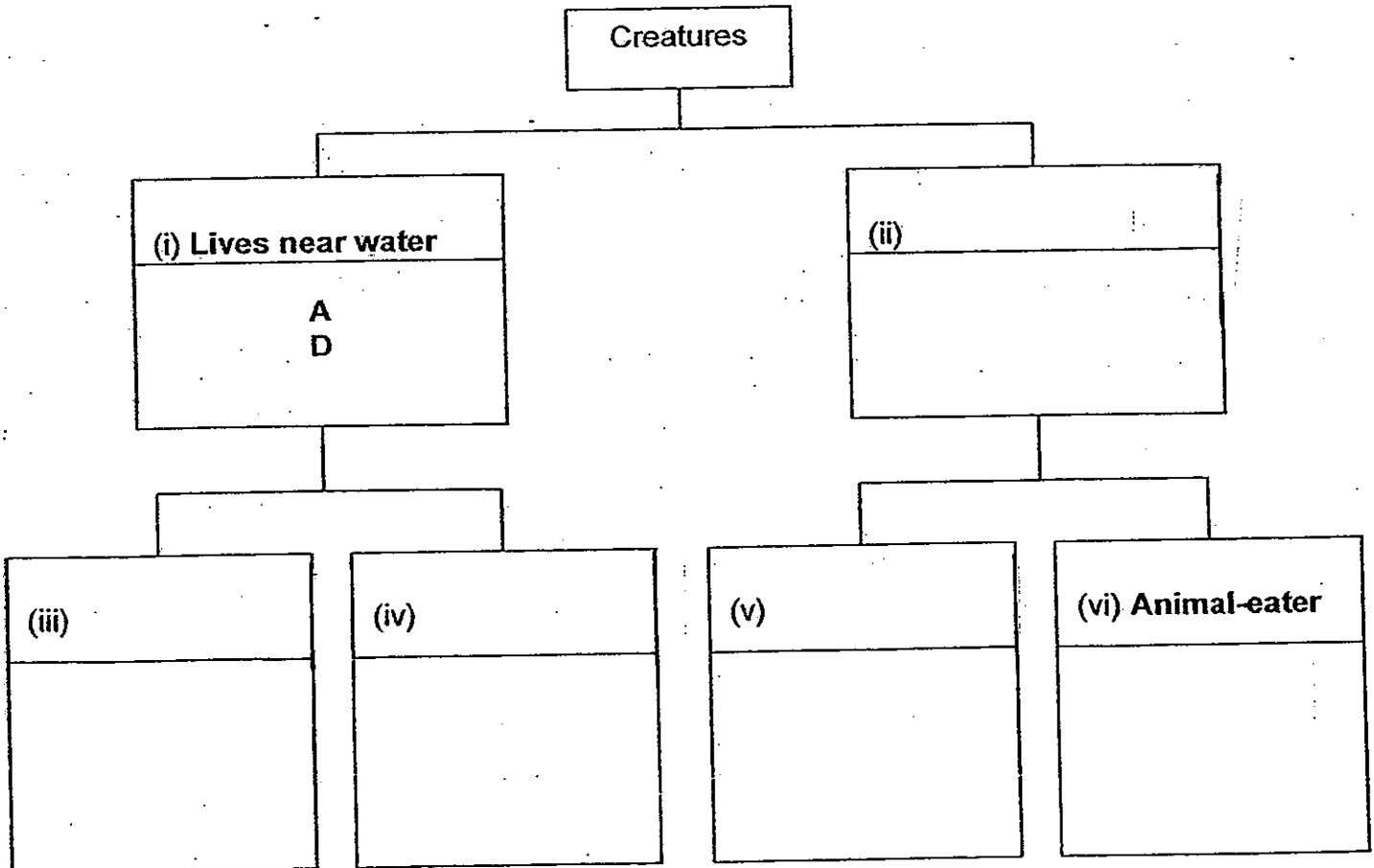

42. Jacob was shown 2 animal skulls during a field trip as shown below.

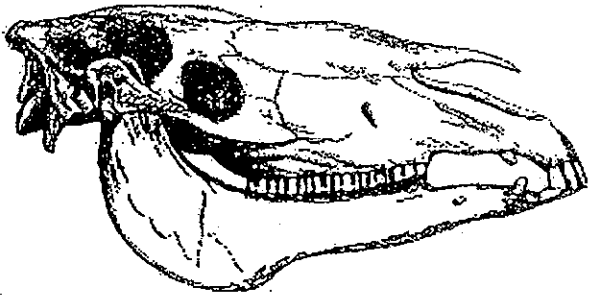

Skull A



Skull B

- a) Which Skull, A or B, most likely belonged to an animal that eats other animals for food? (1m)

- b) State a reason for your answer in (a). (1m)

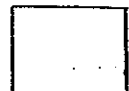

43. The diagram below shows how different bird feet are classified according to certain characteristics of A, B, C and D.

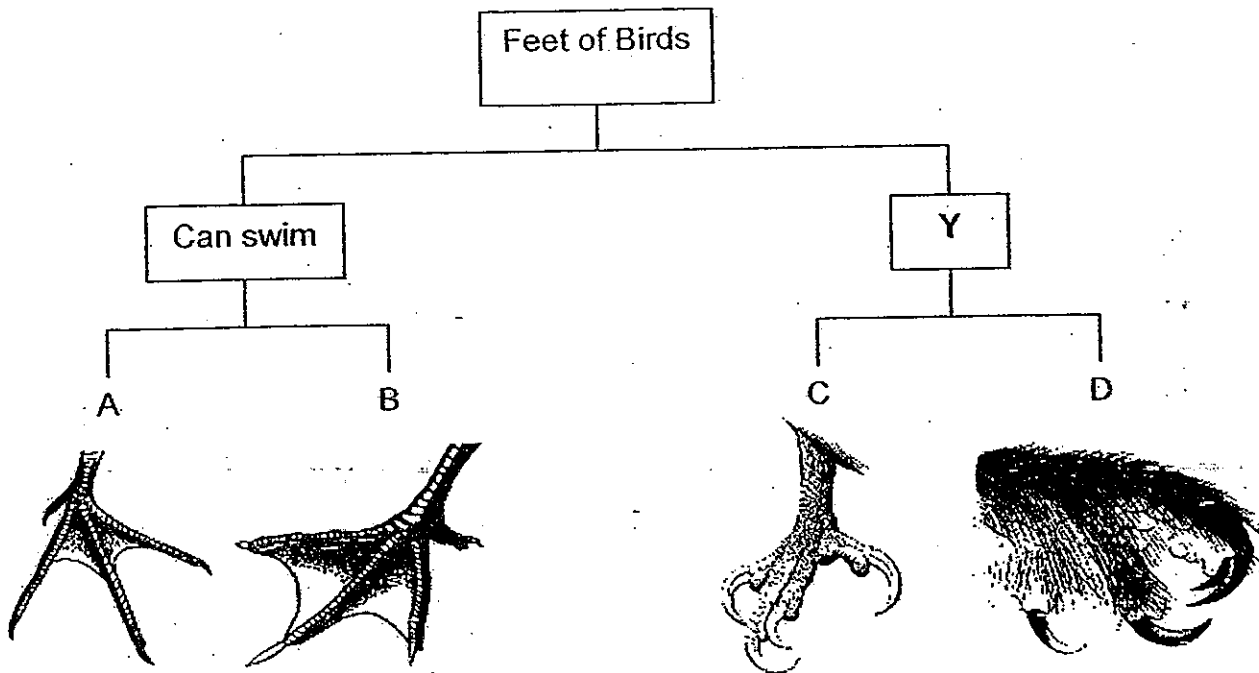

- a) What could Heading Y be?

(1m)

Study Foot X below.

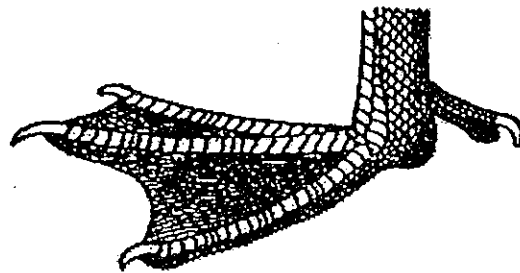

Foot X

- b) In which group, A, B, C or D would you place Foot X?

(1m)



44. Trina placed four identical plants in identical cylinders and poured water into each cylinder.

She then placed the four set-ups, A, B, C and D next to the window for an hour.

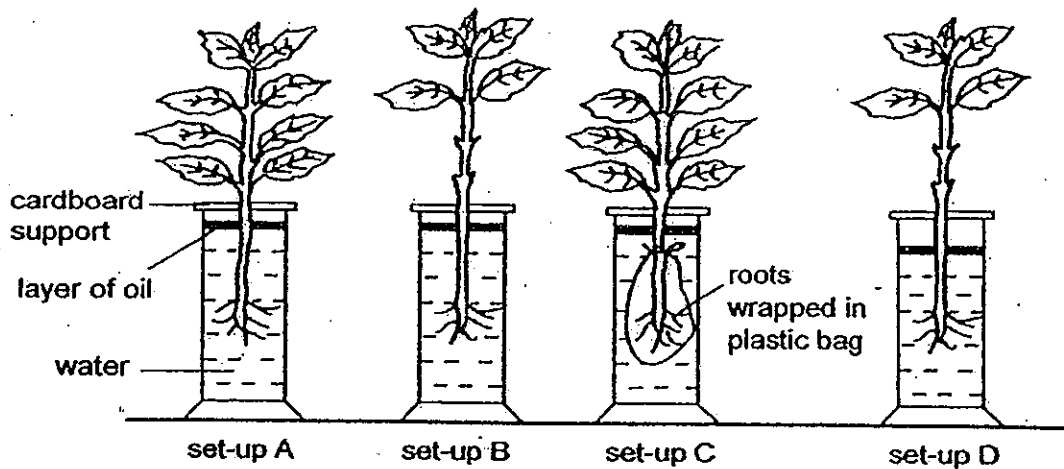

At the end of the experiment, Trina measured the amount of water left in each cylinder. The table below shows her results.

Set-Up	Amount of water left (ml)
A	185
B	195
C	200
D	180

a) Which two set-ups should Trina use if she wanted to investigate if the number of leaves a plant has affects the amount of water it takes in? (1m)

b) Based on her investigation in (a), what can she conclude from the above results? (1m)

c) What would Trina observe of the plant in set-up C after 1 day? Explain your answer. (1m)

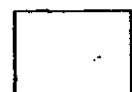

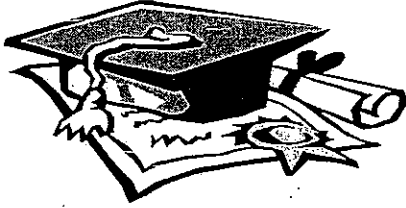

ANSWER SHEET

EXAM PAPER 2010

**SCHOOL : HENRY PARK PRIMARY
SUBJECT : PRIMARY 4 SCIENCE**

TERM : SA1

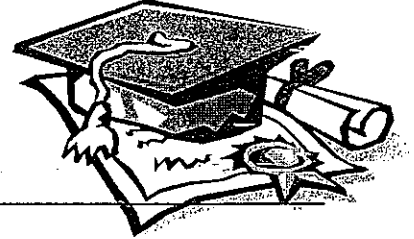

Q1	Q2	Q3	Q4	Q5	Q6	Q7	Q8	Q9	Q10	Q11	Q12	Q13	Q14	Q15	Q16	Q17
1	2	4	4	3	2	1	2	1	1	3	2	2	4	4	3	2

Q18	Q19	Q20	Q21	Q22	Q23	Q24	Q25	Q26	Q27	Q28	Q29	Q30
4	1	3	1	3	1	4	3	4	3	4	2	3

31a) Air was in the plastic cup and air occupies space, so it will not allow water to enter the cup.

31b) Casey Would see that the dry tissue becomes wet.

31c) The air in the plastic sup escape from the hole , so the water enter the cup to occupies the space.

32a) (i) Solid (ii) Gas (iii) Liquid

32b) There is many pockets of air in the sponge . The sponge becomes smaller when pressed. The air in sponge is compressed.

32c) Heat does not have mass and does not occupies space but matter is anything that have mass and occupies space.

33a) The milk loss heat to the inner steel can, then the ice cube to the salt mixture.

33b) Steel is a good conductor of heat , but plastic is a poor conductor of heat. So it can conduct heat from the milk to the ice more quickly.

34a) Some of the heat from the Teh Tarik drink loss to the surrounding air.

34b) The Teh Tarik drink lose heat to the surrounding air and it reached into the same temperature to the science room.

35a) Container C.

35b) Container C is the best insulator of heat and it allows heat to pass through slowly.

35c) Plastic

36a) The warm water cause the lid to expand.

36b) i) Ken cold use the ice cubes and put it in Glass A.
ii) Glass A would contract.

37a) Gained Heat – Ice cubes
Lost heat - Hot Lemon tea

37b) The ice cubes gain heat and melts into the hot lemon tea

38a)

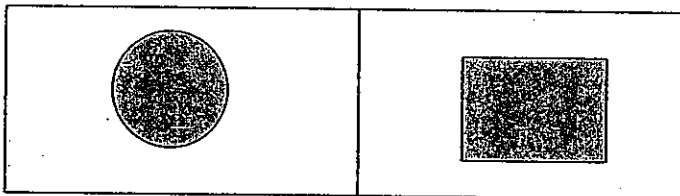

38b)

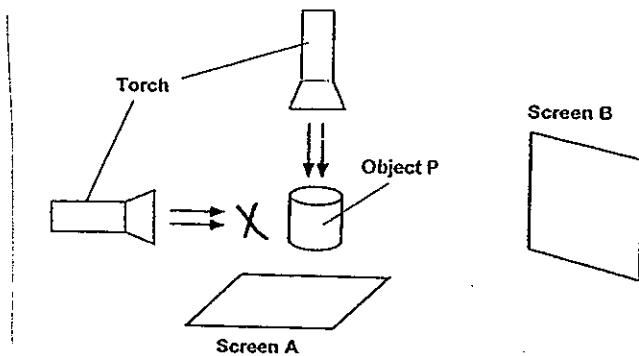

39a) 46 cm

39b) She can conclude that the further the object, the smaller the shadow cast.

39c) The size of shadow will become bigger.

40a) 210 units of light

40b) Distance between liquid and light the distance between the torch and the liquid.

41a) ii) Lives in mountains – B C E F

iii) Plant-eater – A

iv) Animal-eater – D

v) Plant-eater – B E

vi) Animal-eater – C F

42a) Skull B

Page 2

42b) Skull B have sharp teeth.

43a) Cannot swim

43b) Group B

44a) Set up A and B

44b) the number of leaves does affect the amount of water taken in.

44c) The plant would be dried up.

----- end -----