

PEI CHUN PUBLIC SCHOOL

PRIMARY 4

SEMESTRAL ASSESSMENT 2 2019

**SCIENCE
SECTION A**

Time: 1 h 45 min

Name: _____ ()

Class: Primary 4 / () _____

Date: 25 October 2019

Science Teacher: _____

Section A (28 × 2 marks)

For questions 1 to 28, choose the most suitable answer and shade its number (1, 2, 3 or 4) on the Optical Answer Sheet (OAS) provided.

1 Which of the following statements is true about most reptiles?

- (1) They live in water.
- (2) They have scales.
- (3) They do not have legs.
- (4) They give birth to their young.

2 The table below shows how some living things can be grouped.

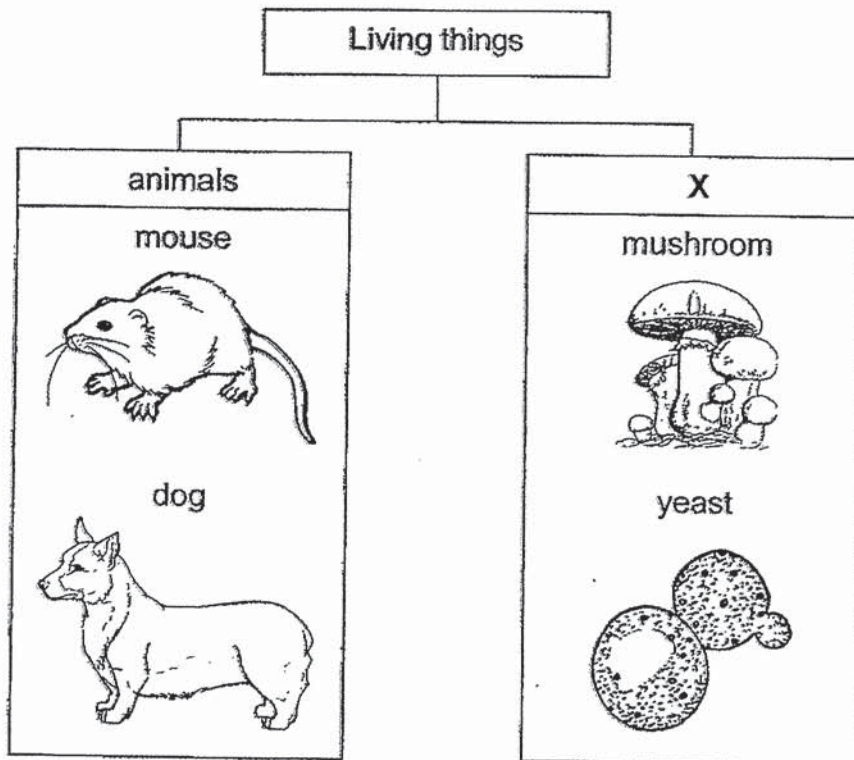

Which one of the following is the most suitable heading for group X?

- (1) fungi
- (2) bacteria
- (3) flowering plants
- (4) non-flowering plants

3 Aida put a glass solid block into a container of water.

At which position, A, B, C or D, would the block most likely to be found?

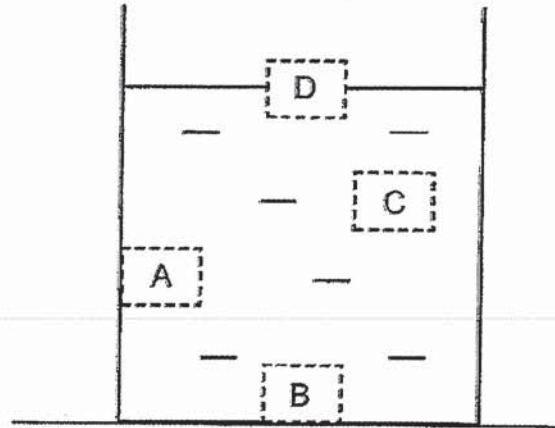

- (1) A
- (2) B
- (3) C
- (4) D

4 Ronald places a metal spoon in a cup of hot tea.

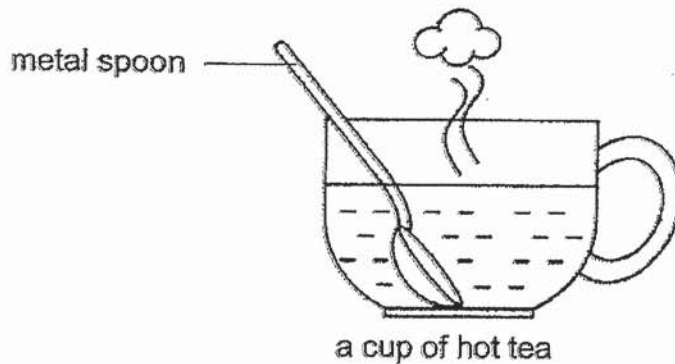

The spoon becomes hotter after a while. Why is this so?

- (1) The cup loses heat to the hot tea.
- (2) The spoon loses heat to the hot tea.
- (3) The spoon gains heat from the hot tea.
- (4) The hot tea gains heat from the spoon.

5 In which one of the following will the two magnets push each other away?

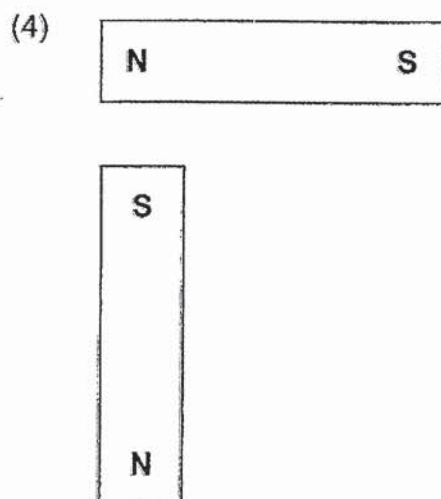
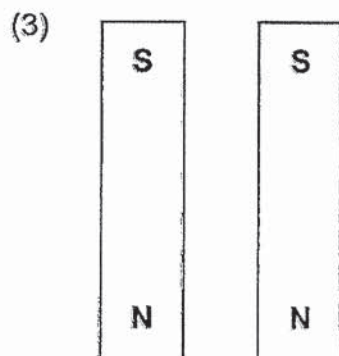
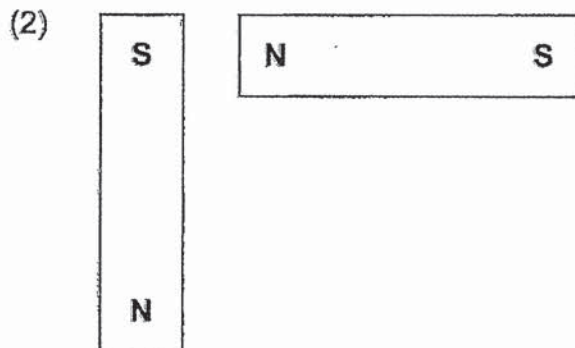
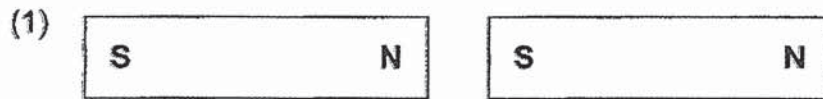

- 6 The diagram below shows the growth of a young plant with two missing stages R and S.

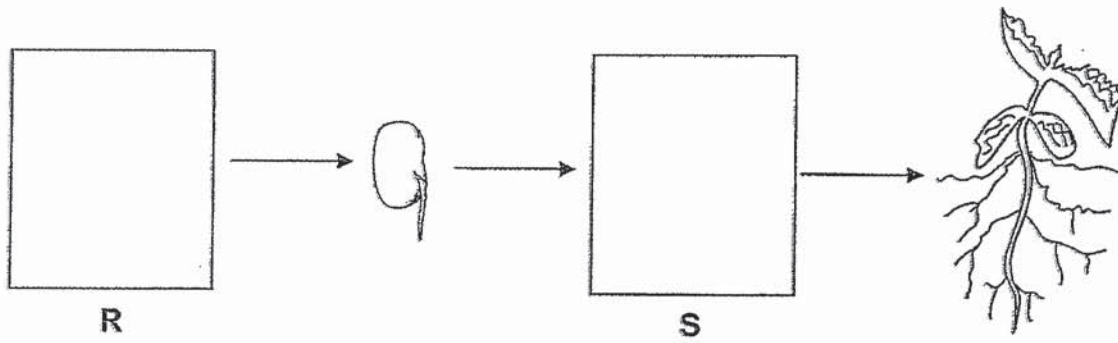

Which of the following best represent stages R and S?

| | R | S |
|-----|---|---|
| (1) | | |
| (2) | | |
| (3) | | |
| (4) | | |

7 Study the diagram below.

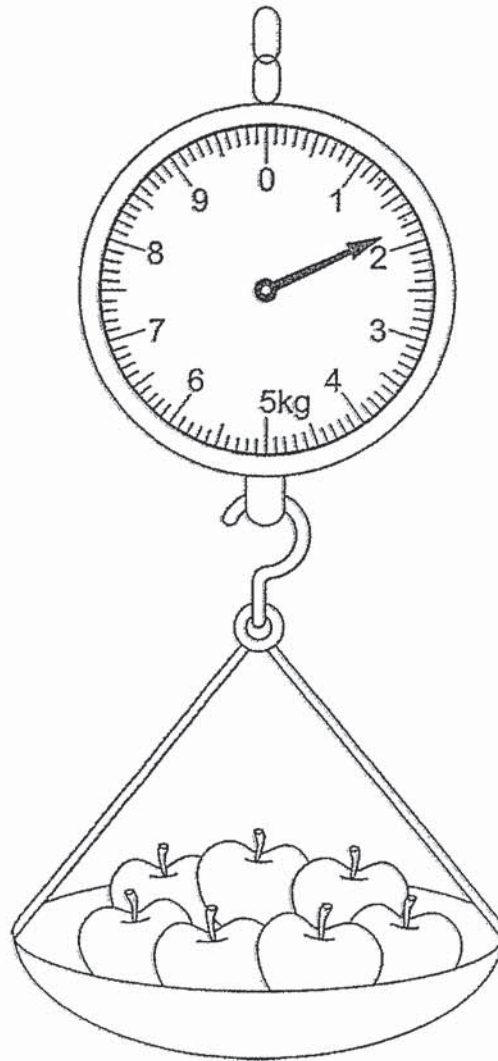

The reading on the weighing scale shows that the mass of the apples is _____ kg.

- (1) 1.6
- (2) 1.8
- (3) 2.0
- (4) 2.2

8 Which organ system is shown in the diagram below?

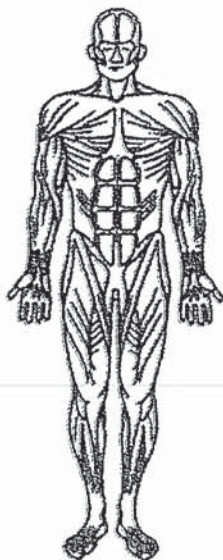

- (1) skeletal system
- (2) muscular system
- (3) circulatory system
- (4) respiratory system

9 The diagram below shows a plant.

Which part, (1), (2), (3) or (4), makes food for the plant?

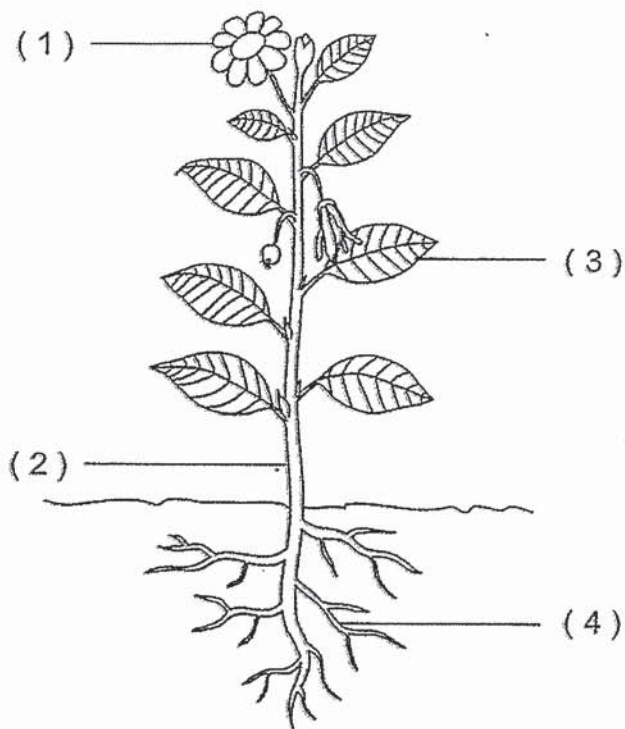

10 Study the diagram below.



Which of the following explains why the boy can see the paper plane?

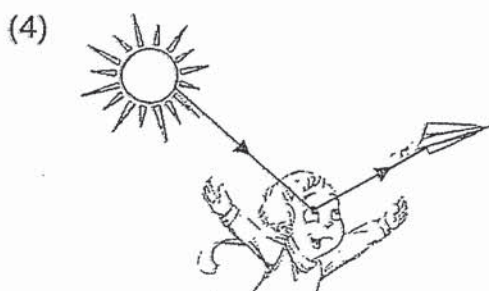
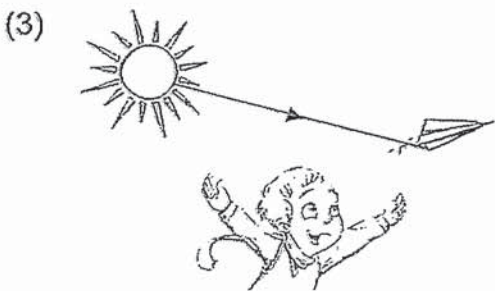
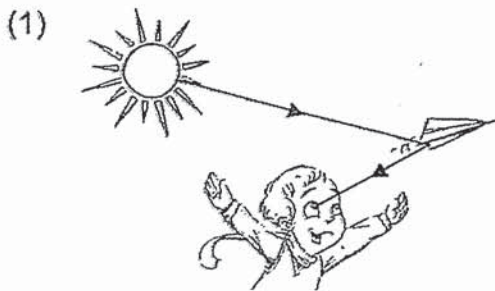
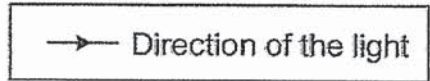

11 Daniel studied the life cycle of an animal shown below.

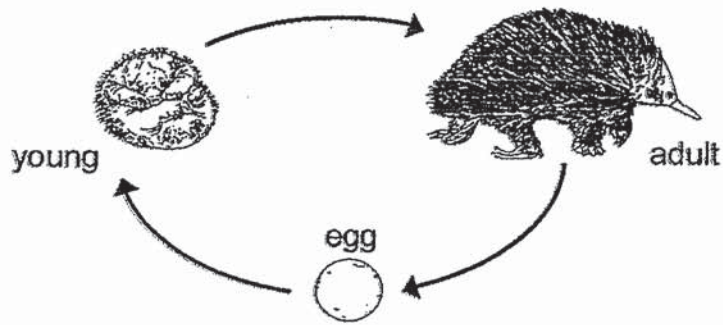

Based on the life cycle, he can conclude that the animal is a living thing because it can _____.

- A : grow
- B : respond
- C : reproduce

- (1) B only
- (2) C only
- (3) A and B only
- (4) A and C only

12 The diagram below shows how different buttons are classified according to certain characteristics, A, B, W, X, Y and Z.

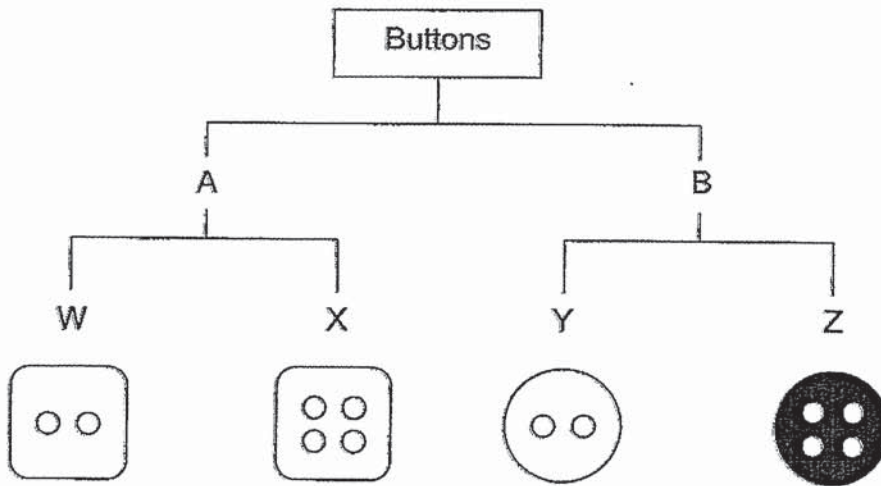

Which of the following correctly shows the characteristics A and Z?

| | A | Z |
|-----|--------|----------------|
| (1) | White | Circle |
| (2) | White | Has four holes |
| (3) | Square | Circle |
| (4) | Square | Has four holes |

13 Which of the following characteristic(s) is/are found in insects, but **not** in other animals?

- A : They lay eggs.
- B : They have wings.
- C : They have six legs.

- (1) B only
- (2) C only
- (3) B and C only
- (4) A, B and C

14 Shanti found a fern that grows on the trunk of trees.

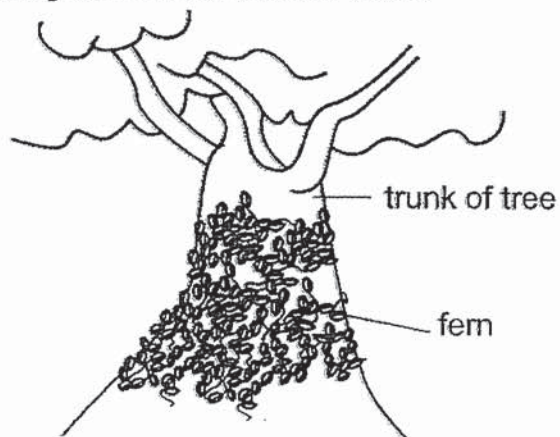

The table below shows Shanti's answers to three questions about the fern.

| Question | Answer |
|---|--------|
| A – Does the fern get its food from the tree? | No |
| B – Does the fern reproduce by spores? | No |
| C – Does the fern have a weak stem? | Yes |

Which question(s) was/were answered correctly?

- (1) C only
- (2) A and B only
- (3) A and C only
- (4) A, B and C

- 15 The following table gives information on four plants, W, X, Y and Z, based on two characteristics. A tick (✓) shows that the plant has the characteristic.

| | W | X | Y | Z |
|--------------------|---|---|---|---|
| Grow on land | | ✓ | | ✓ |
| Reproduce by seeds | ✓ | | | ✓ |

The diagram below shows a plant that grows in a pond.

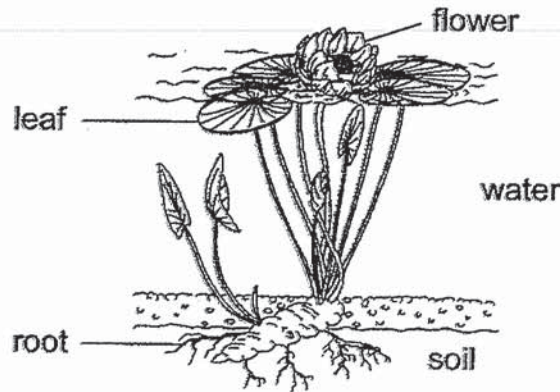

Which of the following is most likely to be the plant?

- (1) W
 - (2) X
 - (3) Y
 - (4) Z
- 16 Vicky wanted to find out if the amount of fertiliser would affect the height of a plant. She used two similar pots of plant for her experiment.

The table shows what she used for her experiment.

| | Pot X | Pot Y |
|--|---------------------|---------------------|
| Height of plant at the start of the experiment | 10 cm | 10 cm |
| Amount of water given daily | 150 cm ³ | 180 cm ³ |
| Amount of fertiliser added to the soil | 5 g | 10 g |
| Height of plant at the end of the experiment | 15 cm | 20 cm |

Which of the following was the reason why her experiment was not a fair test?

- (1) Amount of water given daily was different.
- (2) Amount of fertiliser added to the soil was different.
- (3) Height of plant at the end of the experiment was different.
- (4) Height of plant at the start of the experiment was the same.

- 17 Rahim conducted an experiment to find out how quickly bacteria G can reproduce when it is kept at different temperatures.

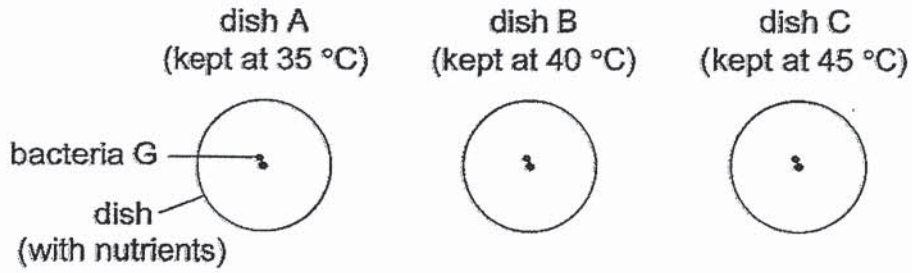

He observed the three dishes after one day and concluded that bacteria G reproduced slower as the temperature increases.

Which of the following correctly shows Rahim's observations at the end of his experiment?

| | dish A | dish B | dish C |
|-----|--------|--------|--------|
| (1) | | | |
| (2) | | | |
| (3) | | | |
| (4) | | | |

- 18 Mingjie tested three types of string Q, R and S by hanging weights from each string. He increased the weights until the string broke. The maximum weight that the strings could hold before breaking is shown below.

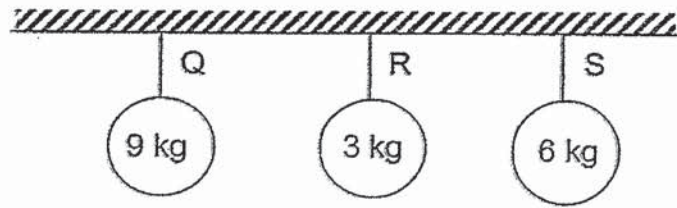

He then tried a few arrangements of hanging different weights.

Which of the following arrangements would be possible?

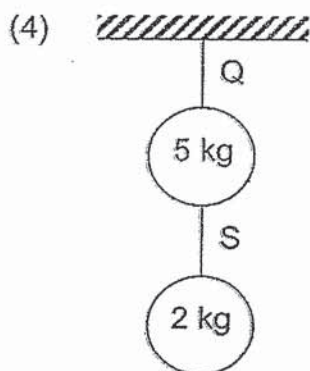
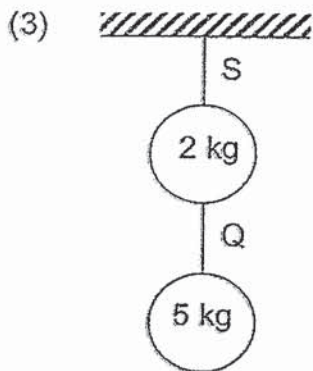
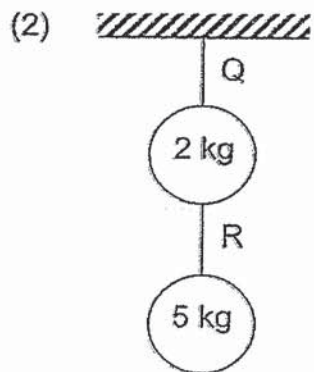
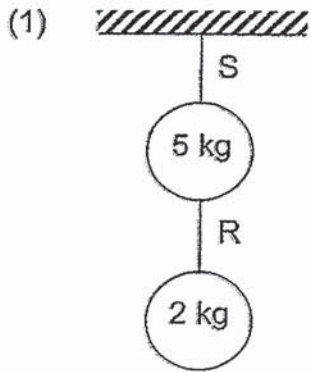

- 19 Four different magnets, A, B, C and D, were held at different heights above a tray of paper clips. The diagram below shows the number of paper clips attracted by each magnet.

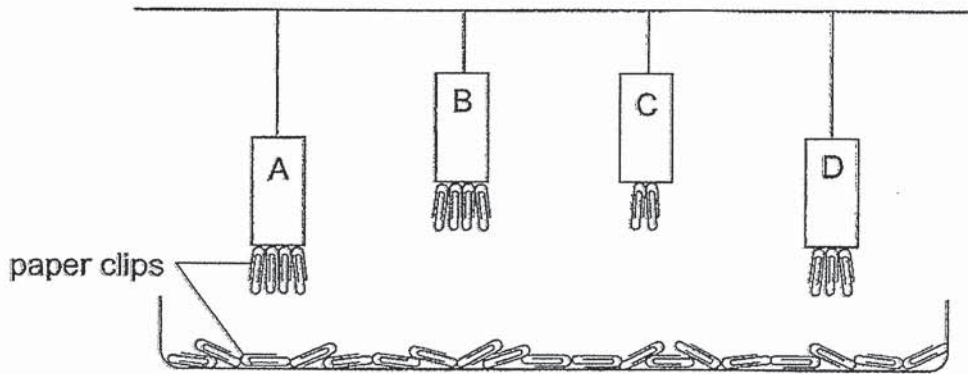

Based on the diagram, which of the following conclusions is definitely correct?

- (1) Magnet B is the strongest.
 - (2) Magnet C is the weakest.
 - (3) Magnets A and B are equally strong.
 - (4) Magnet C is weaker than magnet D.
- 20 X, Y and Z are organs in the digestive system. The graph below shows the amount of undigested food leaving each organ after a meal.

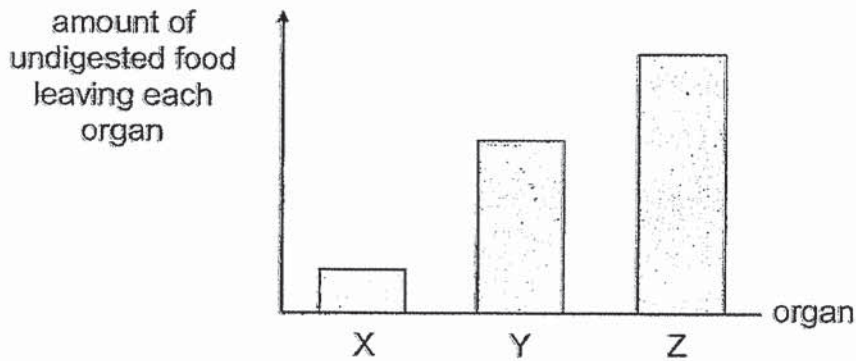

Which of the following is correct?

| | Mouth | Stomach | Large intestine |
|-----|-------|---------|-----------------|
| (1) | X | Y | Z |
| (2) | Y | X | Z |
| (3) | Z | Y | X |
| (4) | Z | X | Y |

- 21 Four identical iron bars, W, X, Y and Z, were made into temporary magnets using the stroke method as shown below.

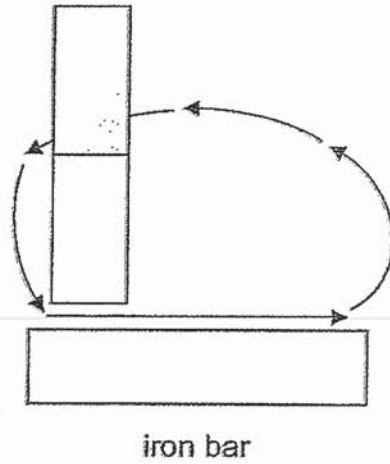

The graph below shows the number of paper clips attracted by each of the magnetised iron bar.

| Iron bar | Number of paper clips attracted |
|----------|---------------------------------|
| W | 6 |
| X | 4 |
| Y | 1 |
| Z | 10 |

Which of the iron bars has been stroked the most number of times?

- (1) W
- (2) X
- (3) Y
- (4) Z

22 J, K, L and M are the stages in the life cycle of a mosquito.

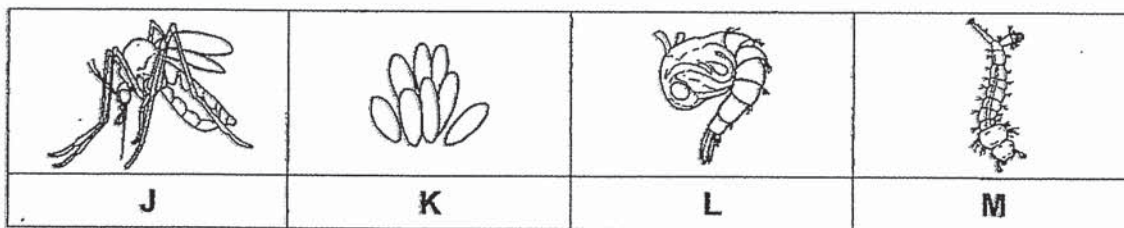

Which of the following correctly shows the life cycle of the mosquito?

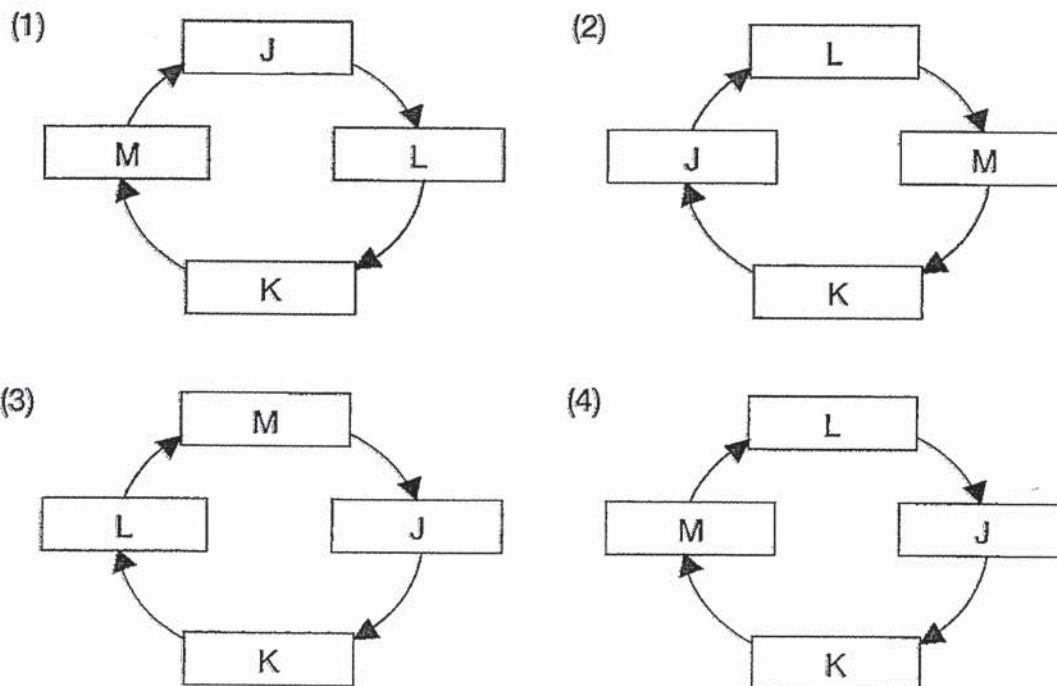

23 The graph below shows the number of days for each stage of the life cycle of insect A.

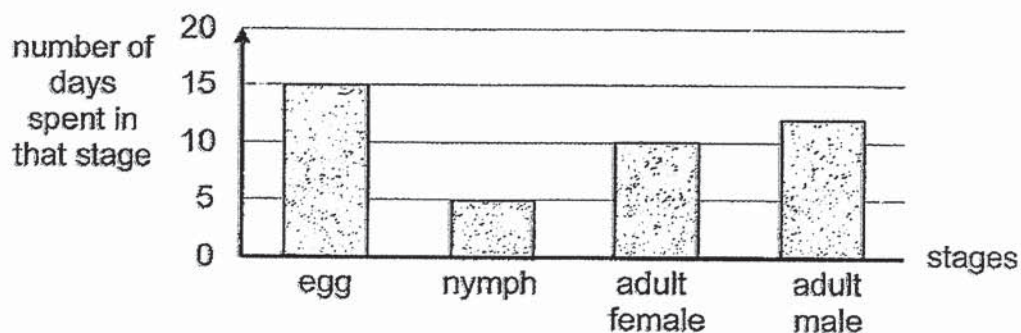

Based on the graph, which of the following statements is true about insect A?

- (1) It has 4 stage life cycle.
- (2) It hatches from the egg after the 15th day.
- (3) It takes 5 days to develop from an egg into a nymph.
- (4) After hatching, it takes about 10 days to become an adult female.

- 24 Sue placed substances G and H in two glass beakers as shown in diagram 1. Diagram 2 shows what happened to the substances when she tilted the two beakers.

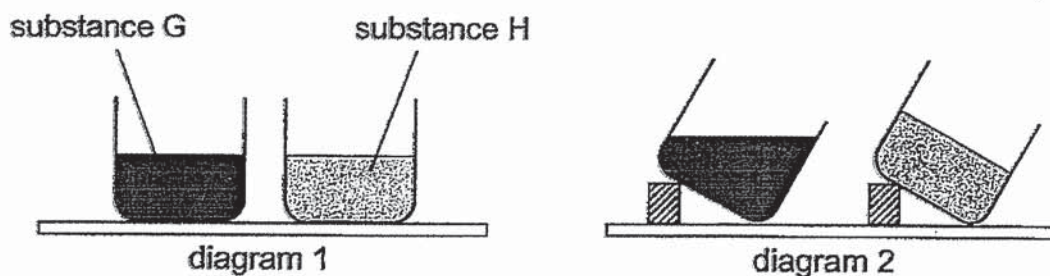

Which of the following shows the correct state(s) of G and H at room temperature?

| | substance G | substance H |
|-----|-------------|-------------|
| (1) | liquid | solid |
| (2) | solid | liquid |
| (3) | liquid | liquid |
| (4) | solid | solid |

- 25 The diagram below shows a syringe connected to a container. The container has a capacity of 250 cm^3 .

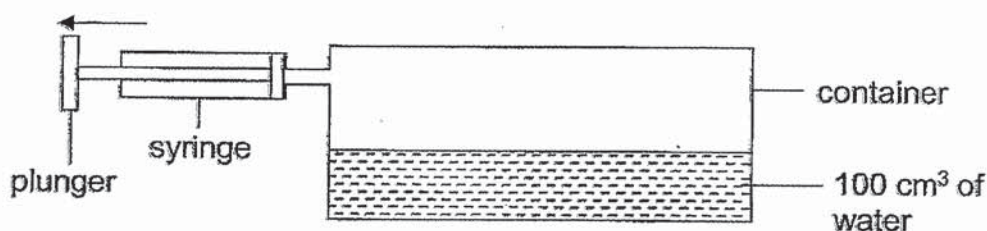

When the plunger of the syringe was pulled back completely, 30 cm^3 of air would be drawn out of the container.

Which of the following shows the correct volume of air and water in the container after the plunger was pulled back completely?

| | Volume of air (cm^3) | Volume of water (cm^3) |
|-----|---------------------------------|-----------------------------------|
| (1) | 120 | 100 |
| (2) | 120 | 130 |
| (3) | 150 | 100 |
| (4) | 150 | 130 |

- 26 An experiment was conducted to investigate whether light can pass through four sheets, P, Q, R and S, made of different materials.

The sheets were arranged in two set-ups, A and B, as shown.

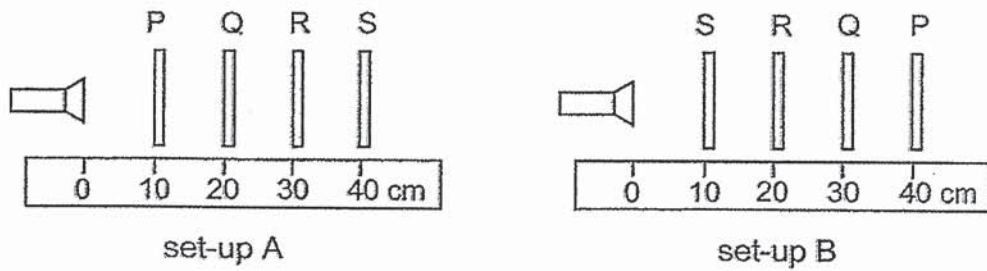

The distance travelled by the light in each set-up was measured and the results are shown in the graph below.

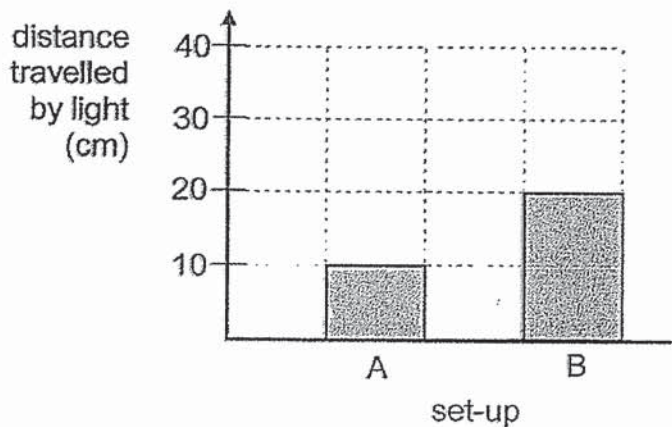

Which of the following correctly describes sheets P, Q, R and S?

| Does it allow light to pass through? | | | | |
|--------------------------------------|-----|----------|-----|----------|
| | P | Q | R | S |
| (1) | yes | no | yes | yes |
| (2) | no | yes | no | no |
| (3) | yes | no | yes | not sure |
| (4) | no | not sure | no | yes |

27 The diagram below shows two glasses, A and B, which are stuck together.

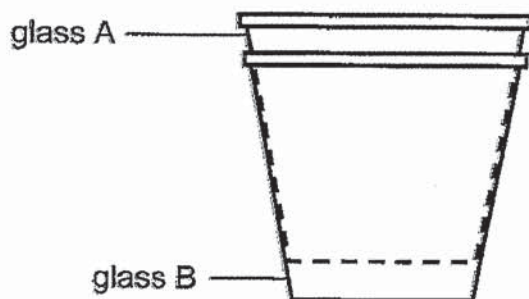

Bill tries to separate the two glasses but finds it difficult to do so. What could Bill do in order to separate the two glasses more easily?

- (1) Pour iced water into glass A and put glass B in iced water.
- (2) Pour iced water into glass A and put glass B in warm water.
- (3) Pour warm water into glass A and put glass B in iced water.
- (4) Pour warm water into glass A and put glass B in warm water.

28 Trinie carried out an experiment as shown below. She put a balloon in the bottle and stretched its end over the mouth of the bottle. She then placed the bottle in a basin of ice cubes for fifteen minutes.

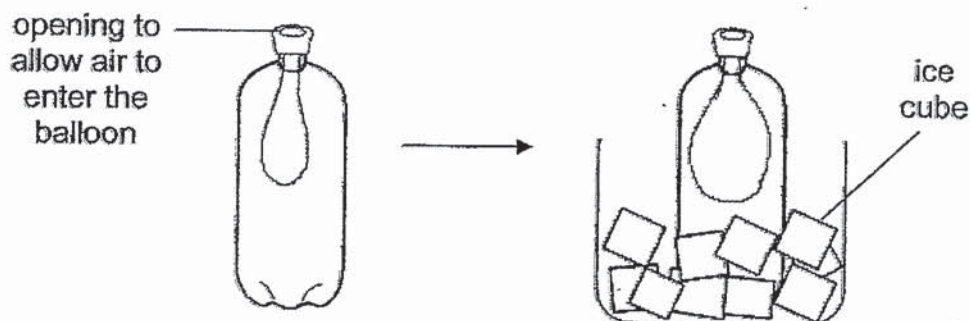

Based on your observation, which one of the following best explains why the balloon became inflated?

- (1) The bottle lost heat and contracted.
- (2) The balloon gained heat and expanded.
- (3) The air inside the bottle lost heat and contracted.
- (4) The air inside the balloon gained heat and expanded.

End of Section A

PEI CHUN PUBLIC SCHOOL

PRIMARY 4

SEMESTRAL ASSESSMENT 2 2019

**SCIENCE
SECTION B**

Time: 1h 45 min

Name: _____ ()

Class: Primary 4 / () _____

Date: 25 October 2019

Science Teacher: _____

Parent's Signature: _____

| | |
|------------------|------------|
| SECTION A | 56 |
| SECTION B | 44 |
| TOTAL | 100 |

INSTRUCTIONS TO CANDIDATES

DO NOT OPEN THIS BOOKLET UNTIL YOU ARE TOLD TO DO SO.

FOLLOW ALL INSTRUCTIONS CAREFULLY.

ANSWER ALL QUESTIONS.

WRITE YOUR ANSWERS IN THIS BOOKLET.

Section B (44 marks)

For questions 29 to 41, write your answers in the spaces provided.

- 29 Aini found a fish in the sea. When she went near the fish, it swallowed huge amount of water to inflate its body as shown.

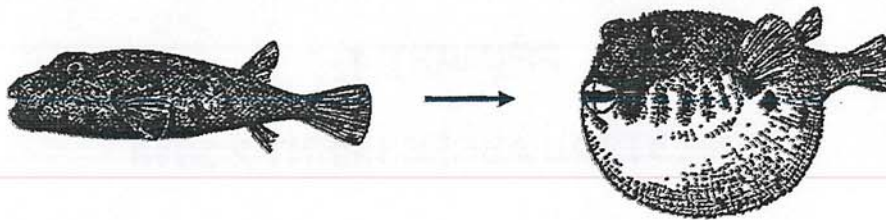

(a) Fill in each blank with a suitable word.

- (i) The fish inflated its body when it sensed danger.

This shows that the fish is a living thing as it can _____ [1]

- (ii) The fish needs air, water and _____ to stay alive. [1]

- (iii) To get air in the water, the fish breathes through its _____. [1]

(b) The table below shows how some animals can be grouped.

| | Has a tail | Does not have a tail |
|--------------------|------------|----------------------|
| Has legs | E | F |
| Does not have legs | G | H |

Which group, E, F, G or H, does the fish belong to? [1]

| | |
|-------|--|
| SCORE | |
|-------|--|

30 The diagram below shows the human digestive system.

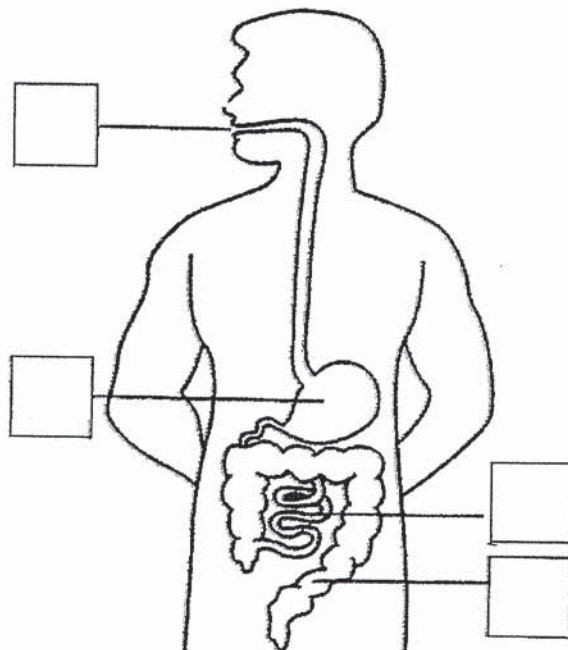

- (a) Put the letter 'A' in a box above to show where digestion first takes place. [1]
- (b) Put the letter 'B' in a box above to show where digestion ends. [1]
- (c) Fill in the blank using the following helping words. [1]

| | | | |
|-----------------|--------|-----------------|-------|
| large intestine | gullet | small intestine | mouth |
|-----------------|--------|-----------------|-------|

Digested food is absorbed into the blood in the _____.

31 Some animals were classified as shown below.

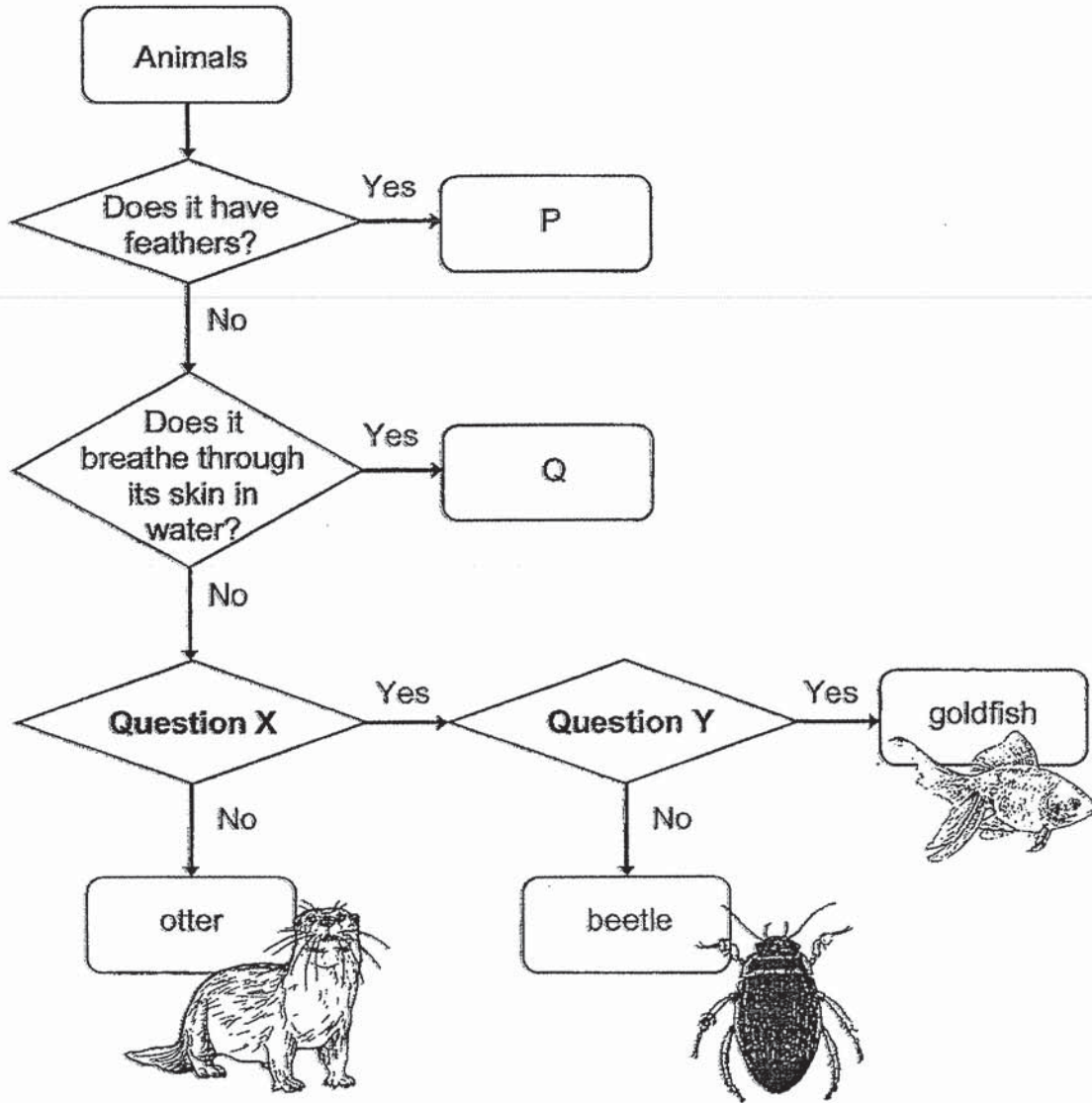

(a) Circle the correct answer. [1]

Animal P could be a (*mammal* / *bird* / *insect*).

(b) Which of the following animals could animal Q be? [1]

Tick (✓) in the correct box.



frog



dolphin

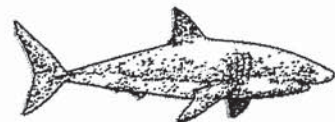

shark

| | |
|-------|--|
| SCORE | |
|-------|--|

(c) What were questions X and Y?
Tick (✓) in the correct boxes.

[2]

| | Question X | Question Y |
|----------------------|------------|------------|
| Does it lay eggs? | | |
| Does it give birth? | | |
| Does it have hair? | | |
| Does it have scales? | | |

32 Classify the following animals according to the number of stages in their life cycle.

[2]



chicken



frog



beetle

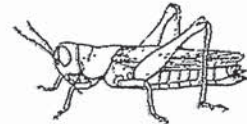

grasshopper

| Three stages | Four stages |
|--------------|-------------|
| | |

- 33 Tom carried out an experiment on the growth of mould on strawberries. He kept three similar strawberries in three identical glass jars as shown below. He covered the jars to make them airtight. Strawberry C was cut in half, so it has a bigger surface area than strawberries A and B.

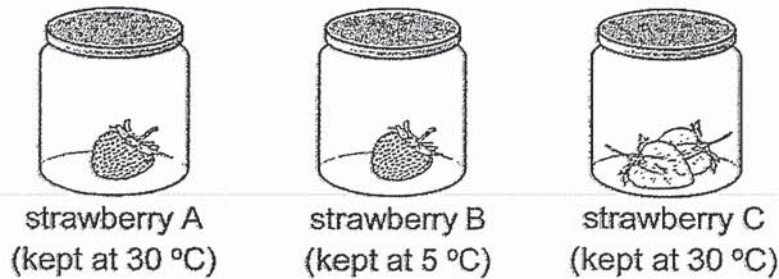

He measured and recorded the amount of mould growing on each of the strawberries after eight days.

- (a) Which strawberry, A or B, would have more mould growing on it after eight days? Give a reason your answer. [1]

- (b) His results for strawberries A and C are shown below.

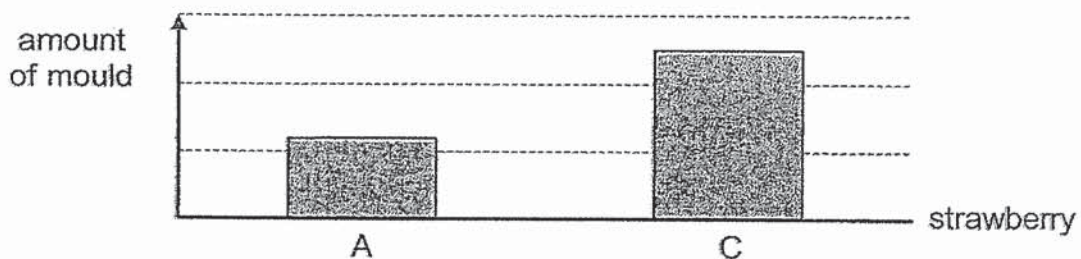

Circle the correct answer. [1]

Based on his results, he can conclude that as the surface area of the strawberries increased, the amount of mould growing on it

(*decreased* / *remained the same* / *increased*).

- (c) Tom repeated his experiment with strawberries D and E. He placed a small piece of mouldy strawberry in one of the jars and placed both jars in the same place.

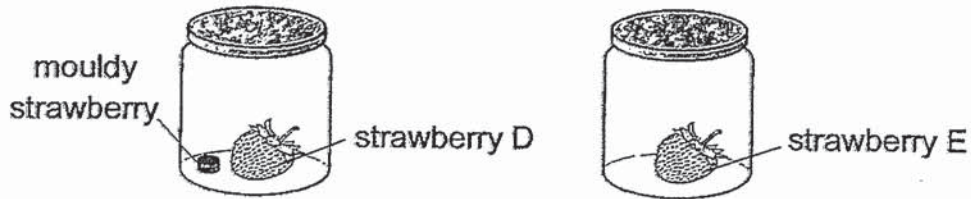

On which strawberry, D or E, would mould first appear?
Give a reason for your answer.

[1]

- 34 Winnie had three grass plants, K, L and M, growing in her garden.

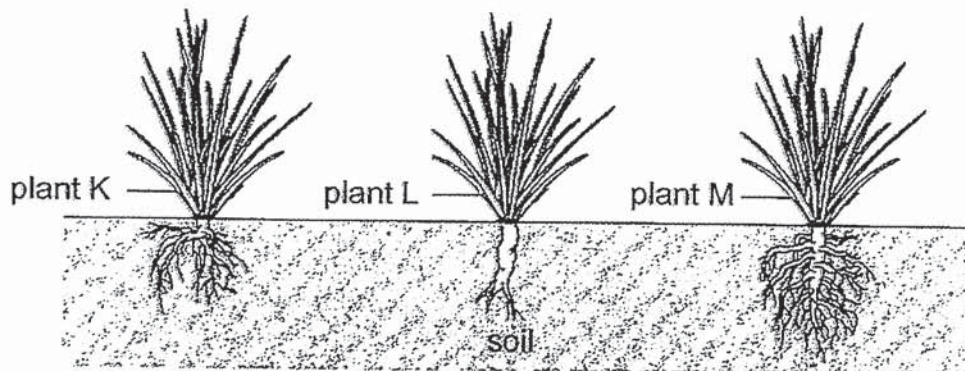

- (a) She observed that plant L did not grow as well as plant K and M when there was little rainfall. Give a reason for her observation.

[1]

- (b) She wanted to remove all the grass plants from her garden. Which grass plant, K, L or M, would be most difficult to pull out? Explain your answer.

[2]

| | |
|-------|--|
| SCORE | |
|-------|--|

35 Si Ling placed two set-ups, A and B, side by side, near an open window.

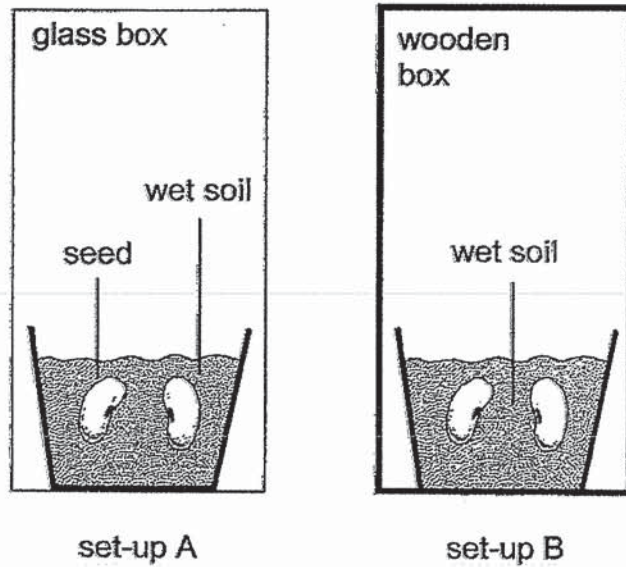

The diagram below shows two of the seedlings after a few days.

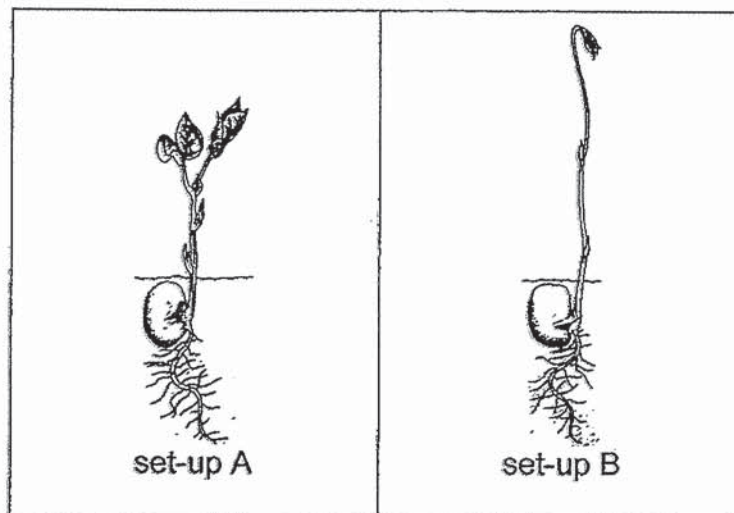

(a) Based on the experimental results, Si Ling concluded that a seed needs light to germinate.

Is she correct? Circle your answer.

[1]

Yes / No / Cannot tell

(b) Give a reason for your answer in (a).

[1]

| | |
|-------|--|
| SCORE | |
|-------|--|

36 Bala shone a torch on his toy and a shadow was formed on the table.

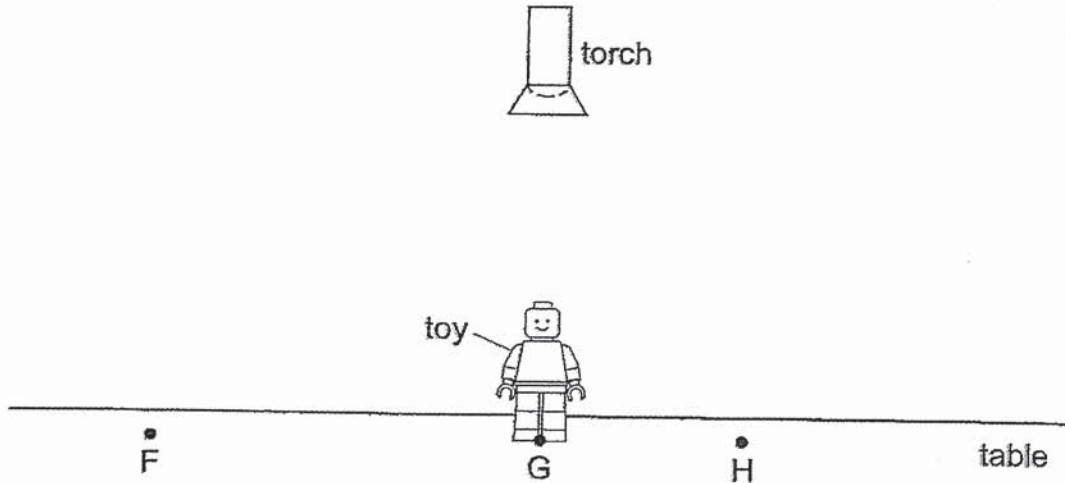

(a) Fill in the blank with a suitable word.

A shadow is formed when light is _____ by an object. [1]

(b) Without moving the torch, Bala placed the toy at positions F, G and H and measured the length of the shadow formed on the table for each position.

His results are shown in the bar graph below.

Which of the bars shows the length of the shadow of the toy at position G?
Write the letter 'G' in the correct box below.

[1]

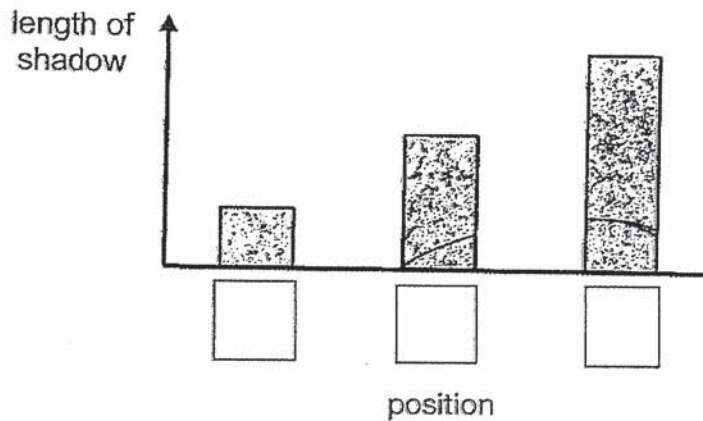

- (c) Bala wanted to put up a shadow performance with three identical toys, A, B and C. The diagram below shows the layout of his stage.

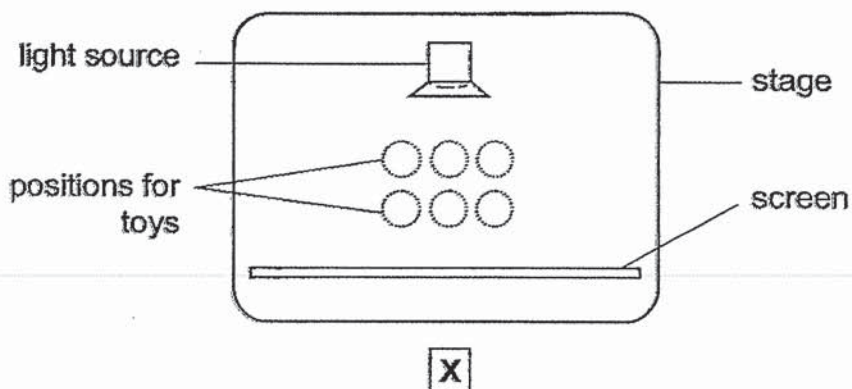

The person at X saw the shadows of the toys on the screen as shown.

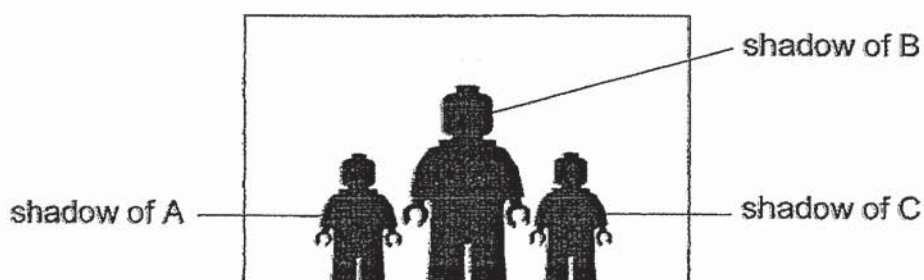

- (i) Which of the following correctly shows the position of the toys on the stage? Tick (✓) in the correct box. [1]

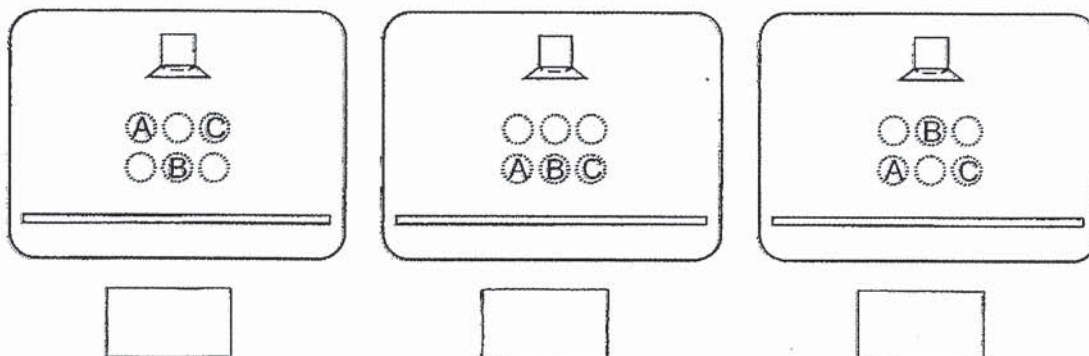

- (ii) Without changing the positions of the toys, suggest one change to Bala's stage layout that would make the shadows of the toys appear bigger. [1]

| | |
|-------|--|
| SCORE | |
|-------|--|

- (iii) Bala set up an experiment in a dark room as shown below. He covered the open side of a wooden box with material P.

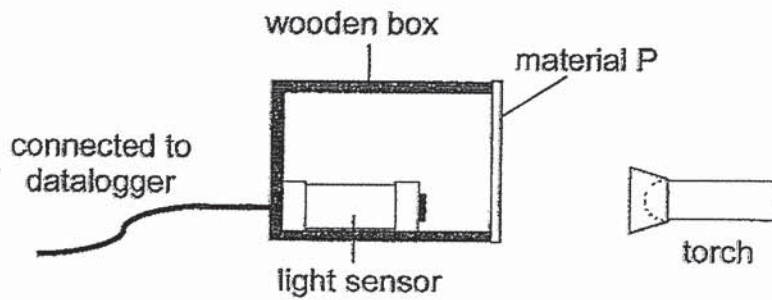

He recorded the amount of light that passed through material P with a light sensor placed in the box. He repeated the experiment using material Q.

The table below shows the results.

| | Without material | Material P | Material Q |
|--|------------------|------------|------------|
| Amount of light detected by sensor (units) | 1500 | 750 | 0 |

Based on Bala's results, which material, P or Q, could be used to make the screen for his shadow performance? Explain your answer.

[1]

- 37 Reuben placed a metal rod and a plastic rod into a tank of boiling water as shown below. Equal amounts of wax were put on the rods.

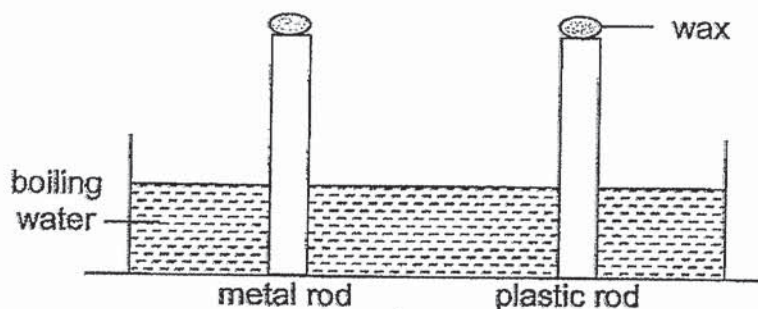

- (a) What would he observe and why?

[2]

The wax on the metal rod melted _____ than the wax on the plastic rod, as metal is a _____ conductor of heat than plastic.

| | |
|-------|--|
| SCORE | |
|-------|--|

- (b) Reuben conducted an experiment with a metal cup and a plastic cup in a room. The cups were of the same size and thickness. He then poured the same amount of hot water into the cups and covered them with identical lids.

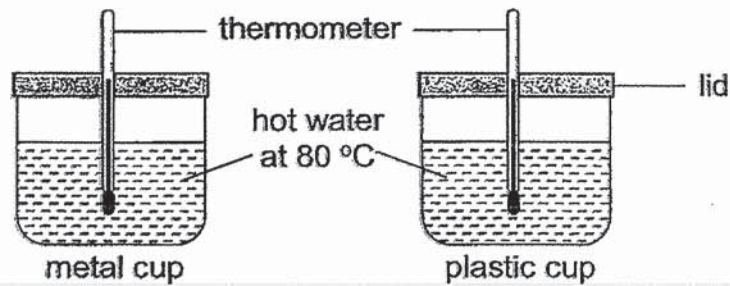

He measured the temperature of the hot water in each cup for 40 minutes. His results are shown in the graph below.

temperature of water in cup ($^{\circ}\text{C}$)

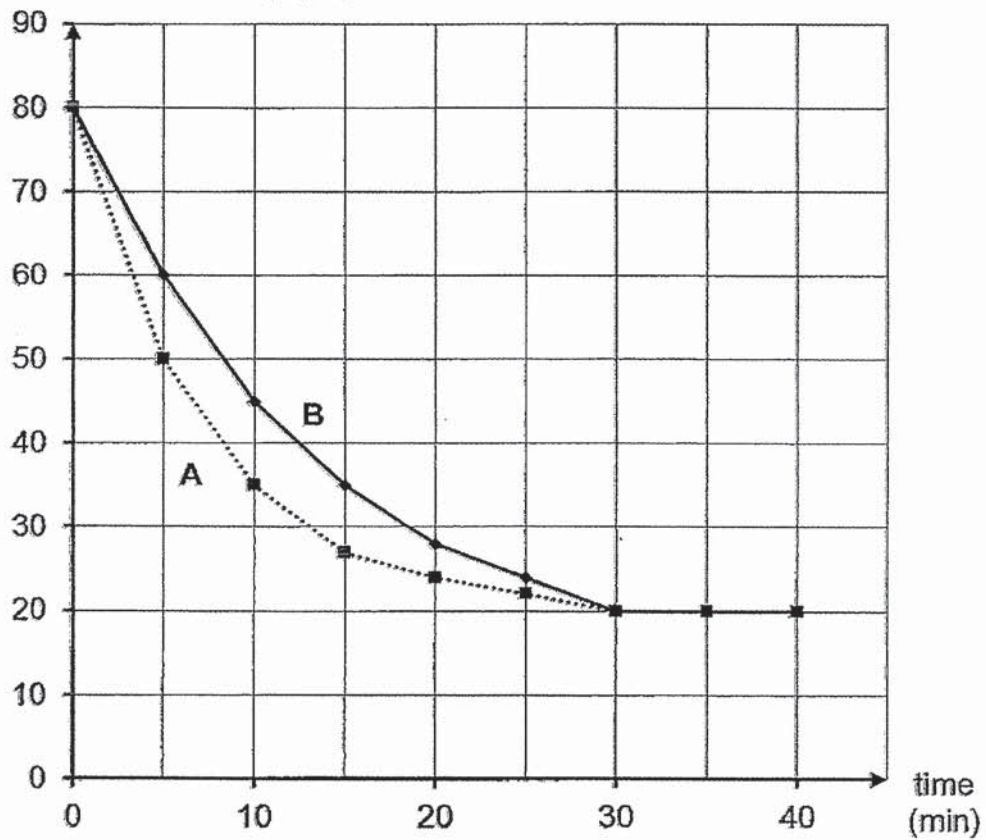

Which graph, A or B, shows the temperature of the hot water in the metal cup? Explain your answer based on the graph above. [1]

- (c) Based on the graph, state the temperature of the room. [1]

_____ $^{\circ}\text{C}$

| | |
|-------|--|
| SCORE | |
|-------|--|

- 38 Kelly glued a piece of tissue paper to the inside of a plastic cup. Then, she inverted the cup and slowly pushed the cup into a basin of water as shown in diagram 1.

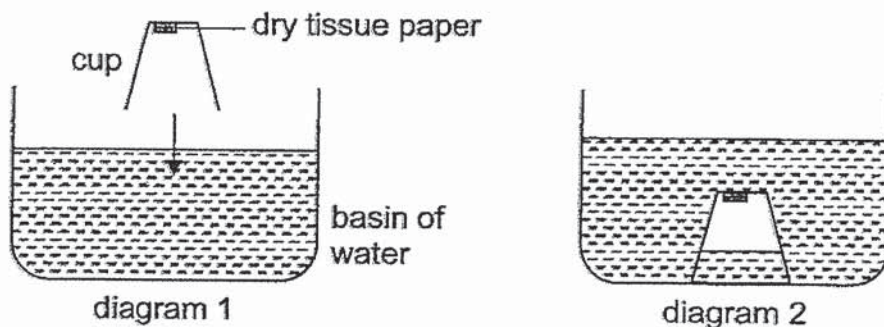

She observed that water could not fill up the cup as shown in diagram 2 and the tissue paper in the cup remained dry.

- (a) Explain her observation. [1]

- (b) Kelly had two identical containers, A and B. She poured 200 cm³ of water into container A and placed some marbles in container B. The height of the marbles in container B was the same as the height of the water in container A.

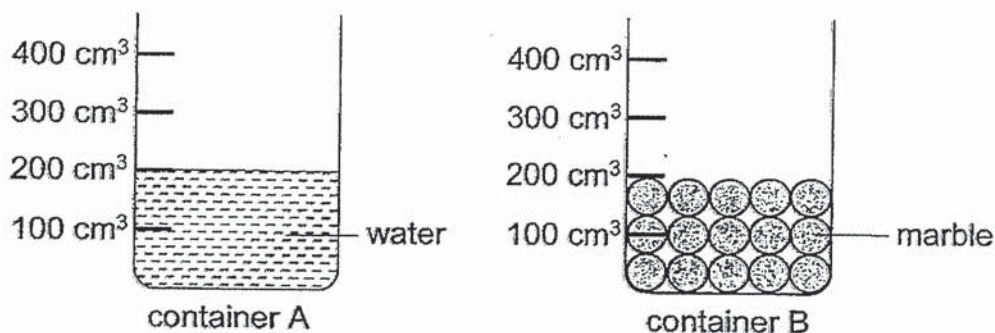

- (i) She poured all the water from container A into container B. Which of the following is most likely to be the total volume of the water and marbles in container B?

Put a tick (✓) in the correct box below. [1]

 200 cm³
 350 cm³
 400 cm³

- (ii) Explain your answer in b (i). [2]

| | |
|-------|--|
| SCORE | |
|-------|--|

- 39 Stephanie set up an experiment with an iron bar shown below. She then held the iron bar above a plastic tray of identical steel pins and counted the number of steel pins attracted by the iron bar.

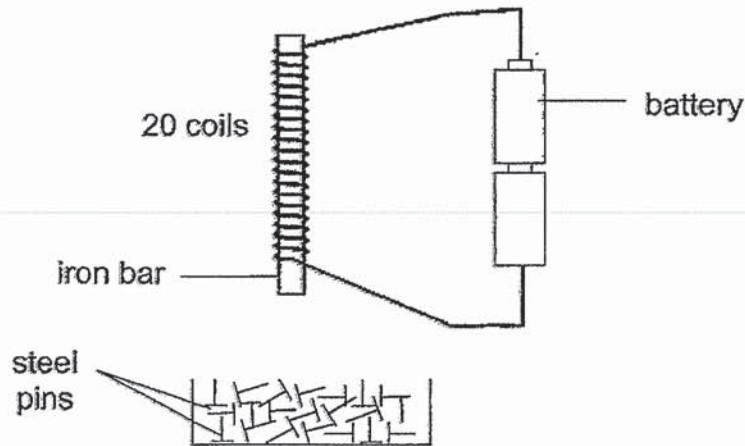

She repeated the experiment with different number of coils of wire around the iron bar. Her results are shown in the table below.

| Number of coils of wire around the iron bar | Number of steel pins attracted by the iron bar |
|---|--|
| 10 | 3 |
| 15 | 6 |
| 20 | 9 |

- (a) Based on Stephanie's results, state the relationship between the number of coils of wire around the iron bar and the number of steel pin attracted by the iron bar. [1]

- (b) Without changing the number of coils of wire around the iron bar, suggest a change to the experiment that will allow the iron bar to attract more than 9 steel pins. [1]

| | |
|-------|--|
| SCORE | |
|-------|--|

(c) Stephanie repeated her experiment, using copper pins instead of steel pins.

Would the iron bar be able to attract the copper pins?
Give a reason for your answer.

[1]

(d) Stephanie wants to find out if the material of the bar will affect the strength of the electromagnet. The diagram below shows three possible set-ups, Q, R and S.

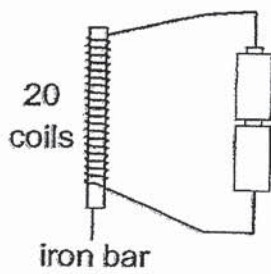

set-up Q

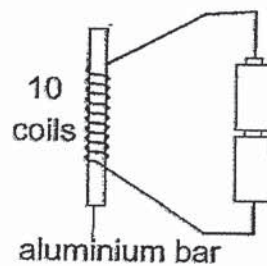

set-up R

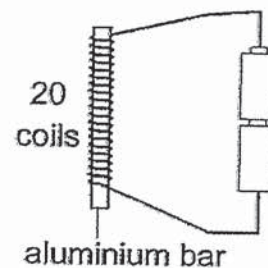

set-up S

Which set-ups, Q, R or S, should Stephanie use to make a correct conclusion?

[1]

Set-ups _____ and _____

- 40 Ryan carried out an experiment on rod A using the set-up shown below. He measured the distance, x , at the middle of the rod after adding each mass.

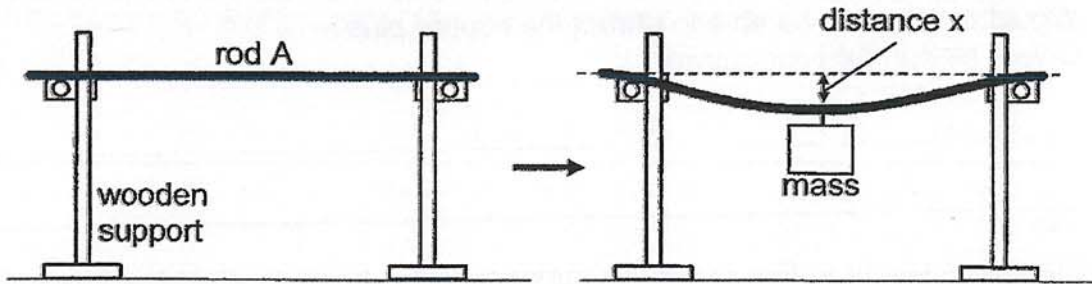

He repeated the experiment using rod B, which was made of a different material but of the same length and thickness. His results are shown below.

distance x (mm)

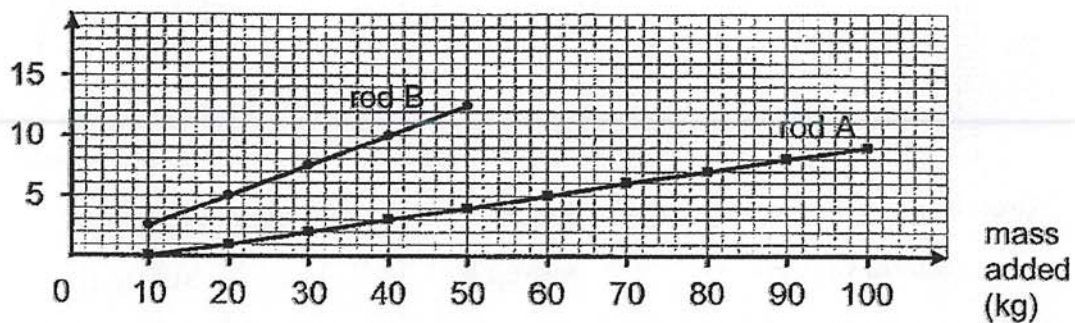

- (a) Name the property of material that Ryan was testing in his experiment. [1]

- (b) Suggest a reason why Ryan was not able to obtain a reading for rod B when the mass added on the rod was more than 50 kg. [1]

- (c) The diagram below shows a climbing frame at a playground.

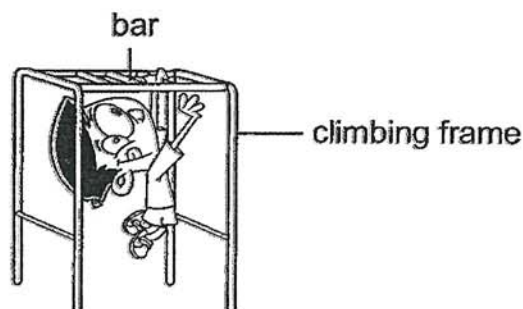

Based on his results, give a reason why rod A is more suitable for making the bar of the climbing frame. [1]

| | |
|-------|--|
| SCORE | |
|-------|--|

- 41 Raju set up an experiment using two identical glass bottles. He connected the two bottles with a glass tube which had a drop of blue ink as shown below.

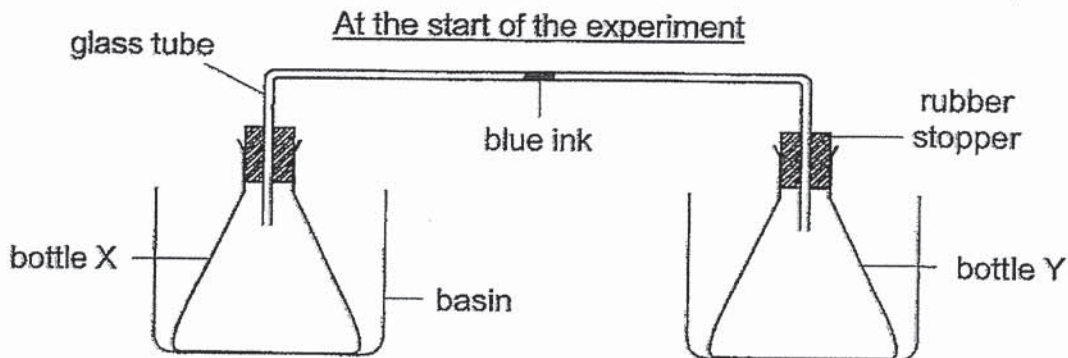

He poured hot water into basin with bottle X and cold water into the basin with bottle Y. After three minutes, he observed that the drop of ink moved towards bottle Y as shown below.

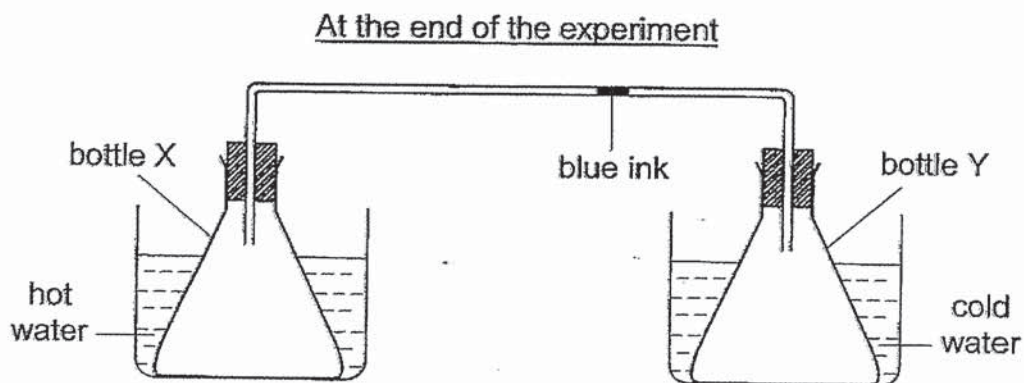

- (a) Explain why the drop of ink moved towards bottle Y at the end of the experiment. [2]

| | |
|-------|--|
| SCORE | |
|-------|--|

(b) Raju removed the bottles from the basins and left them on a table as shown.

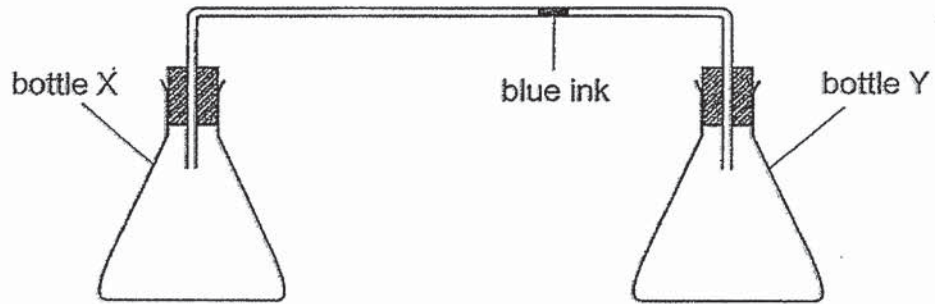

After some time, both bottles returned to room temperature.

Which of the following best describes the change in the position of the drop of ink? Put a tick (✓) in the correct box below. [1]

It did not move.

It moved towards bottle X.

It moved towards bottle Y.

End of Section B

| | |
|-------|--|
| SCORE | |
|-------|--|

YEAR : 2019
LEVEL : PRIMARY 4
SCHOOL : PEI CHUN PUBLIC SCHOOL
SUBJECT : SCIENCE
TERM : SA2

SECTION A

| | | | | | | | | | |
|----------|----------|----------|----------|----------|----------|----------|----------|----------|----------|
| Q1 2 | Q2 1 | Q3 2 | Q4 3 | Q5 3 | Q6 4 | Q7 2 | Q8 2 | Q9 3 | Q10 1 |
| Q11 4 | Q12 4 | Q13 2 | Q14 3 | Q15 1 | Q16 1 | Q17 2 | Q18 4 | Q19 1 | Q20 3 |
| Q21 4 | Q22 4 | Q23 2 | Q24 1 | Q25 3 | Q26 4 | Q27 2 | Q28 3 | | |

SECTION B

- Q29. a) i) This shows that the fish is a living thing as it can respond to changes.
- ii) The fish needs air, water and food to stay alive.
- iii) To get air in the water, the fish breathes through its gills.

b) G

Q30.

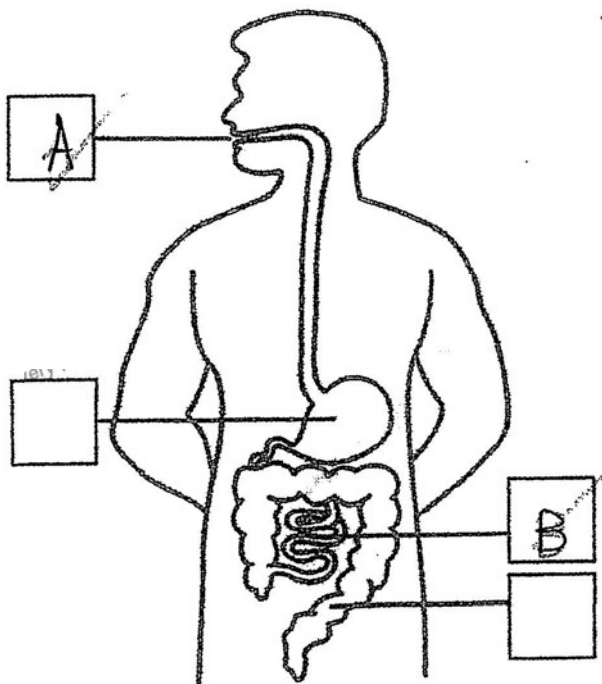

- c) Digested food is absorbed into the blood in the small intestine.

- Q31. a) Bird
 b) Frog
 c)

| | Question X | Question Y |
|----------------------|------------|------------|
| Does it lay eggs? | ✓ | |
| Does it have scales? | | ✓ |

- Q32. Three Stages: Chicken, frog and grasshopper
 Four stages: Beetle

- Q33. a) A, as it was kept in a warmer place and mould needs warmth to grow.
 b) Increased
 c) D. The mould spores from the mould on the mouldy strawberry would land on strawberry D and grow.

- Q34. a) The surface area of the roots of plant L is smaller than the roots of plants K and M, hence when there is little rainfall, plant L will absorb less water and will not grow as well.
 b) Plant M. It has the most roots and they are more widespread, hence plant M is well anchored into the soil. This makes it the most difficult to pull out.

- Q35. a) No
 b) In set-up B, there is no light as the wooden box prevented light from entering. However, the seed still germinated, hence Si Ling's conclusion is wrong.

- Q36. a) A shadow is formed when light is blocked by an object.

b)

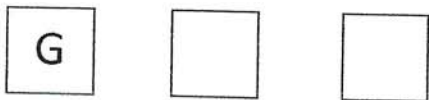

c)

i)

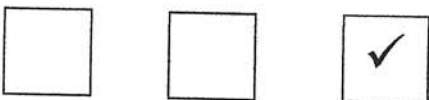

ii) He can move the torch nearer to the toys.

iii) P, as it must allow some light to pass through so that the shadow can be seen.

- Q37. a) The wax on the metal rod melted faster than the wax on the plastic rod, as metal is a better conductor of heat than plastic.

b) Graph A. It shows that the temperature of the hot water decreased at a faster rate. Metal is a good conductor of heat which allows the hot water to lose heat at a faster rate.

c) 20°C

- Q38. a) The air inside the cup occupies space, and hence the tissue paper in the tissue paper in the cup remained dry.
- b) i) 350cm²
- ii) The water will fill up the empty spaces between the marbles, thus the water level will be less than 400cm². Since both the water and marbles take up space, the water level would be 350cm².
- Q39. a) As the number of coils around the bar increases, the number of steel pins attracted by the iron bar increases.
- b) He can add more batteries.
- c) No, as copper is a non-magnetic material.
- d) Set-ups Q and S
- Q40. a) Flexibility
- b) Rod B broke from the amount of weight used.
- c) Rod A can hold the most number of weight, hence it is stronger and more flexible. This allows it to be able to support the weight of children on the climbing frame.
- Q41. a) The air in bottle X expanded as it gained heat from bottle X, which gained heat from the hot water in the basin. The air in bottle Y contracted as it lost heat to bottle Y, which lost heat to the cold water in the basin. Thus, the blue ink moved towards bottle Y.
- b) It moved toward bottle X.

END-OF-PAPER