

**NAN HUA PRIMARY SCHOOL
END OF YEAR EXAMINATION 2007
PRIMARY FIVE
SCIENCE**

Name : _____ ()

Class : Primary 5 / _____

Date : 29 October 2007

Duration : 1 hr 45 min

MARKS	
Sect A:	/ 60
Sect B:	/ 40
Total :	/ 100

Parent's Signature : _____

Section A: (30 x 2marks = 60marks)

For each question from 1 to 30, four options are given. One of them is the correct answer. Make your choice (1, 2, 3 or 4). Shade the correct oval (1, 2, 3 or 4) on the Optical Answer Sheet.

1. Which of the following causes day and night and the formation of tides?

	Day and Night	Formation of Tides
①	The revolution of the Earth around the Sun	The tilting of the Earth's axis
②	The tilting of the Earth's axis	The revolution of the Earth around the Sun
③	The Moon's and Sun's gravity	The rotation of the Earth about its axis.
④	The rotation of the Earth about its axis	The Moon's and Sun's gravity

2. An animal cell was placed in a new environment. The diagram below shows the cell before and after it was introduced to its new environment.

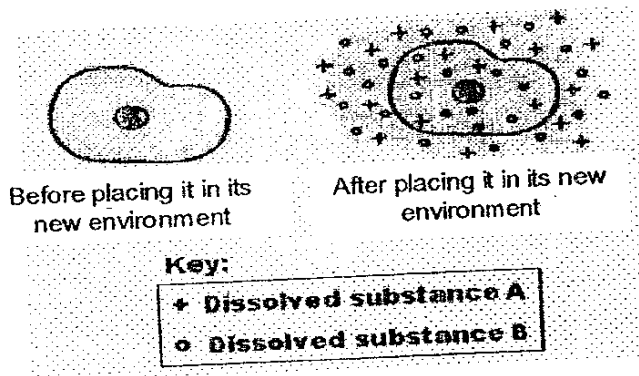

Which of the following can be concluded from the diagram above?

- A: The cell membrane prevents some substances from entering.
- B: Dissolved substances A and B could move in and out of the cell.
- C: The nucleus controlled the movement of dissolved substances A and B within the cell

- ① A only
- ② B only ✓
- ③ A and B only
- ④ A, B and C

3. Which one of the following statements about reproduction is true?

- ① ~~A~~ animals give birth to their young alive.
- ② ~~A~~ living things reproduce by sexual reproduction.
- ③ The fertilised egg of a human being develops in the ovary.
- ④ Living things reproduce to ensure the continuity of their kind.

4. Which of the following conditions are necessary for the germination of seeds?

- A: Water
- B: Sunlight
- C: Oxygen
- D: Warmth

- ① A and C only
- ② A, B and C only
- ③ A, C and D only
- ④ A, B, C and D

5. Which one of the following is not used to generate electricity in power stations?

- ① Tidal energy
- ② Wind energy
- ③ Solar energy
- ④ Sound energy

6. Amy used the following setup as a control for her experiment to be carried out in a sunny place.

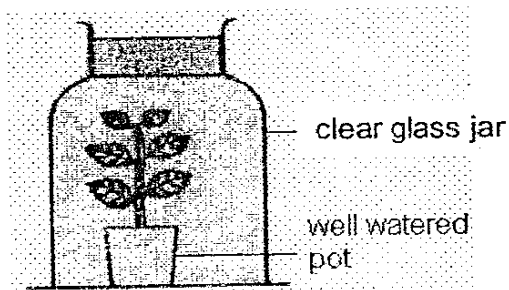

Which one of the following setups can be used with the above control to show that carbon dioxide is necessary for photosynthesis to take place?

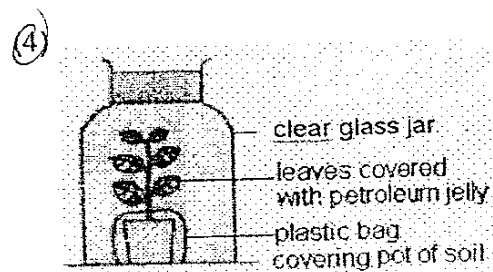
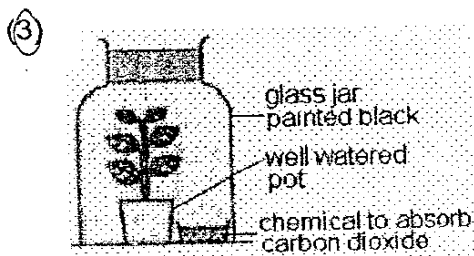
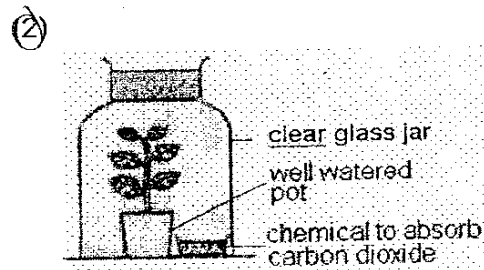
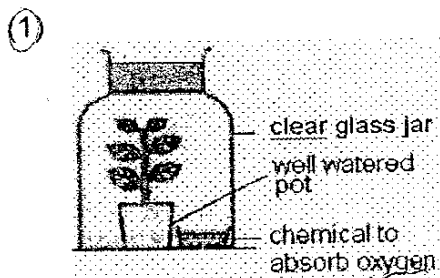

7. The diagram below shows a part of the potato plant.

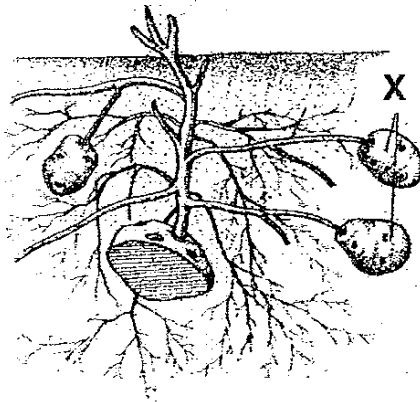

What are the functions of the swollen part marked X?

- A To help the plant reproduce
- B To take in water for the plant
- C To store excess food made by the plant

- ① A and B only
- ② A and C only
- ③ B and C only
- ④ A, B and C

8. Which of the following shows the correct stages of digestion of food?

- A: Undigested food is passed out of the body.
- B: Digested food is absorbed by the blood.
- C: It is cut and sliced into smaller pieces.
- D: It is mixed with digestive juices and changed into a simpler form.

- ① A, B, C, D
- ② C, B, D, A
- ③ D, C, B, A
- ④ C, D, B, A

9. Look at the diagram below.

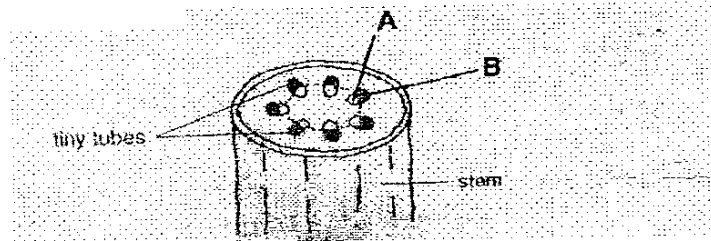

Located within the stem of a sunflower plant are tiny tubes. Identify the substances tubes **A** and **B** transport.

	Tube A	Tube B
(1)	Oxygen	Carbon Dioxide
(2)	Carbon Dioxide	Oxygen
(3)	Water and dissolved minerals	Food
(4)	Food and dissolved minerals	Water

10. Clara took her breakfast five hours ago. How did the food travel in her body before it was absorbed?

- (1) gullet -> stomach -> large intestine -> small intestine
- (2) stomach -> gullet -> small intestine -> large intestine
- (3) gullet -> stomach -> small intestine -> large intestine
- (4) stomach -> gullet -> large intestine -> small intestine

95

11. Five pupils observed some plant and animal cells under the microscope. They recorded their observations and conclusions in the table below.

Name of pupil	Observation on cell parts seen	Conclusion on type of cell
Sharon	Cytoplasm, nucleus, cell membrane	Animal
Dawn	Nucleus, cell wall, cell membrane, chloroplasts	Plant
Mary	Cell membrane, cell wall, nucleus, cytoplasm	Plant
Joe	Cell membrane, cell wall, nucleus	Animal
Derrick	Cell membrane, nucleus, chloroplasts	Animal

Which pupils made the correct conclusion?

- ① Sharon, Dawn and Mary
- ② Mary, Joe and Derrick
- ③ Sharon, Mary and Joe
- ④ Dawn, Joe and Derrick

12. An animal W had a mass of 5g when it was 1 week old. It had a mass of 40g when it was 5 weeks old. Which of the following would have contributed to the increase in mass?

- A: Cell growth
- B: Cell death
- C: Cell division

- ① A only
- ② A and C only
- ③ B and C only
- ④ C only

13. The diagram below shows a developing human baby in a mother's womb.

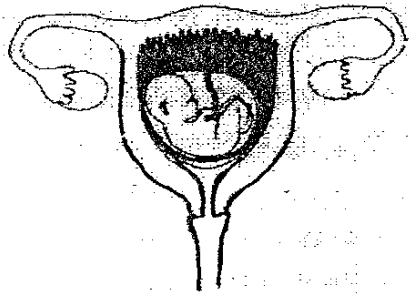

Which of the following statement(s) about the developing baby is/are correct?

- A: It is formed from one fertilised egg cell.
- B: It is made up of many different kinds of cells.
- C: It will have genetic information from only one parent.
- D: It will take one year to develop into a baby, ready to be born.

- ① A only
- ② A and B only
- ③ A, B and D only
- ④ A, B, C, D

14. The diagram below shows the underside of a mature fern frond. Identify the parts marked "X"?

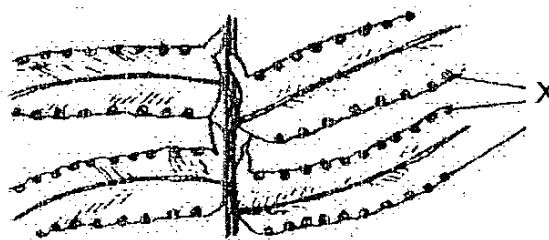

- ① Buds
- ② Fruits
- ③ Seeds
- ④ Spore bags

97

15. The plants in the diagram below have been classified according to the plant parts they reproduce from. Identify the plant part each group of plants reproduce from.

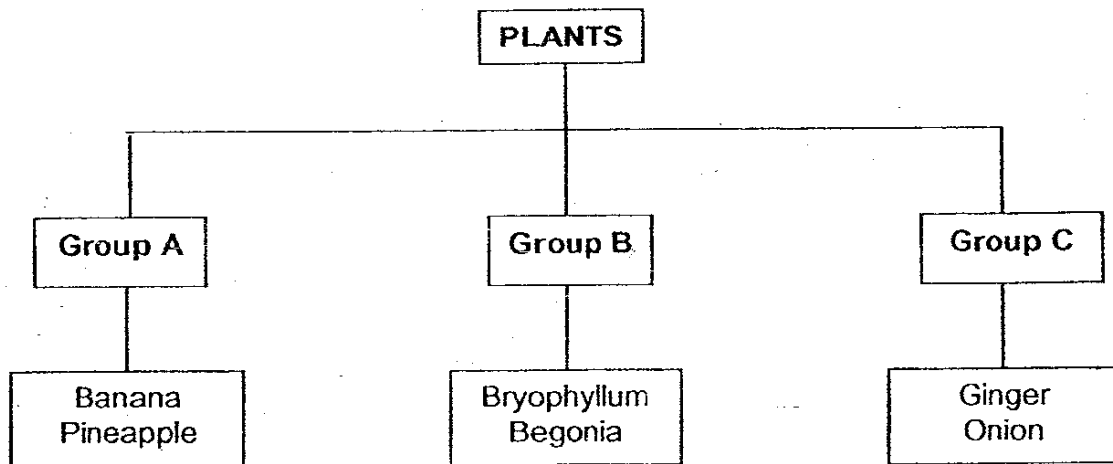

	Group A	Group B	Group C
①	Seeds	Underground stems	Roots
②	Leaves	Spores	Suckers
③	Suckers	Leaves	Underground stems
④	Suckers	Leaves	Roots

16. Phillipe used four objects A, B, C and D, to balance a 300g weight as shown below. Which one of the following objects is the **lightest**?

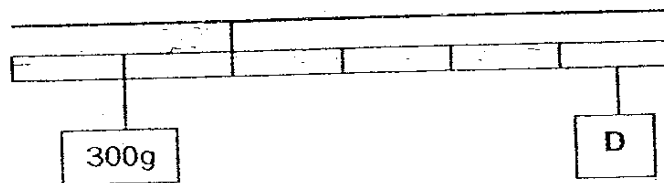
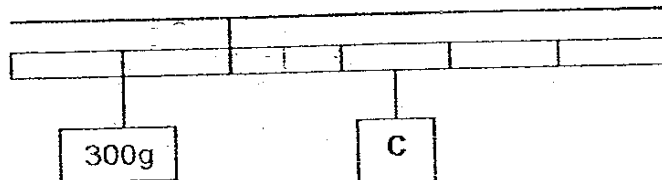
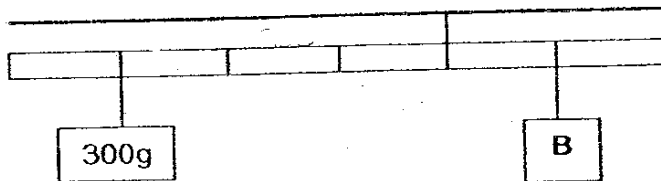
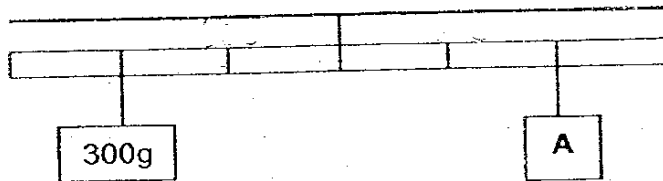

- ① A
- ② B
- ③ C
- ④ D

99

17. Study the diagram carefully.

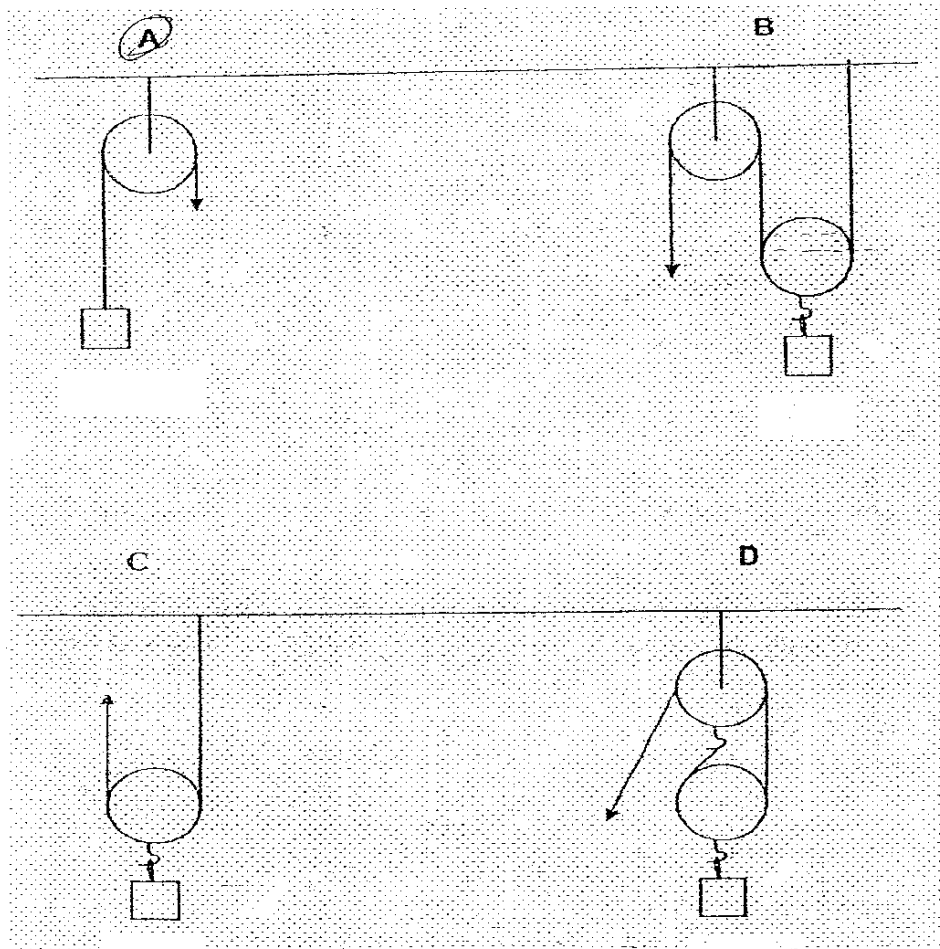

If the load is 400g and a force of 280g is applied, which of the following machines **cannot** lift the load?

- (1) A only
- (2) A and C only
- (3) B and D only
- (4) A, B and C only

100

✓

18. Which of the following statement(s) is/are **true** about the gears shown below?

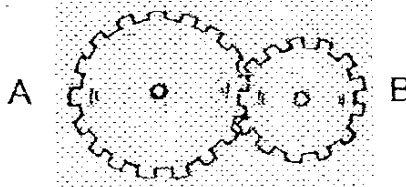

- A: Gear A rotates slower than Gear B.
 B: Gear A rotates faster than Gear B.
 C: They turn in the opposite directions.

- ① A only
 ② B only
 ③ A and C only
 ④ B and C only

19. Seth conducted an experiment to find out the relationship between the effort needed to move the load and the length of the ramp. Using ramps of different lengths, he pulled the load up to a height of 7m and recorded the effort needed.

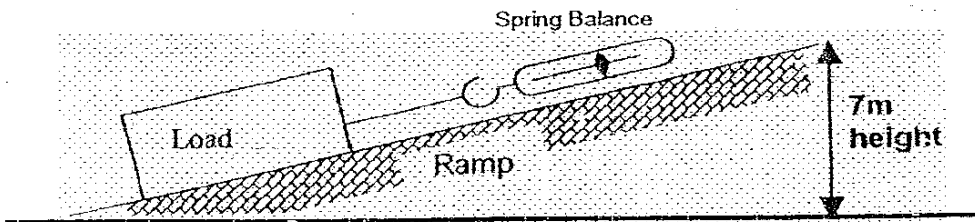

Which one of the following graphs below correctly shows the results obtained?

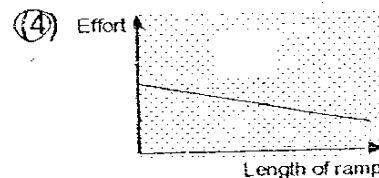
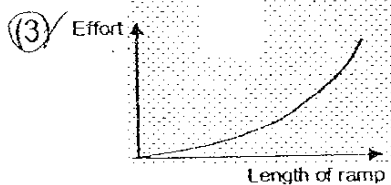
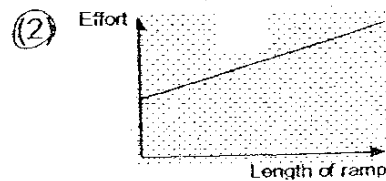
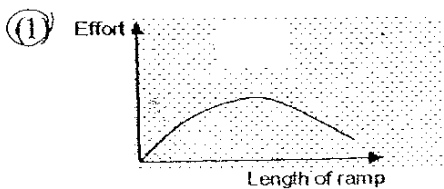

20. Study the circuit shown below. Three bulbs, X, Y and Z are connected differently. Which of the bulb/s will not light up?

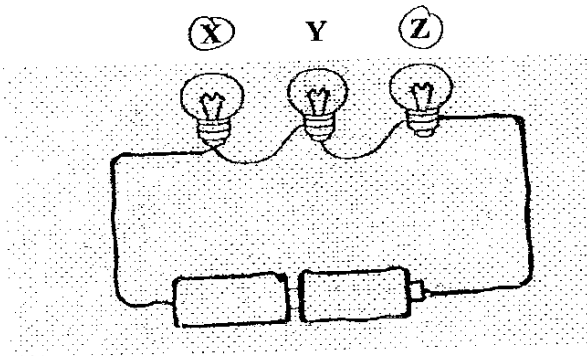

- ① Y only
- ② X and Z only
- ③ X and Y only
- ④ X, Y and Z

21. Study the circuit below carefully.

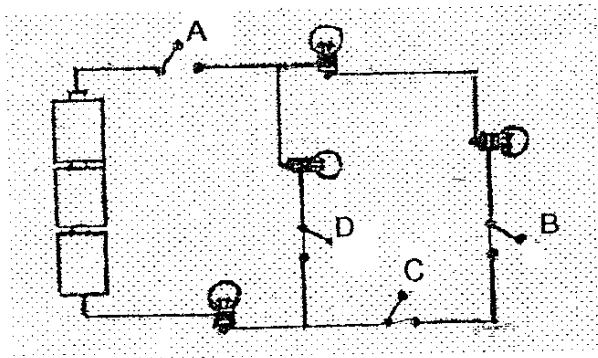

When all the switches are closed, all the bulbs light up. Jamie wants to open one switch which will switch off all the bulbs. Which switch should she open?

- ① A
- ② B
- ③ C
- ④ D

102

22. The diagram below shows an electric circuit.

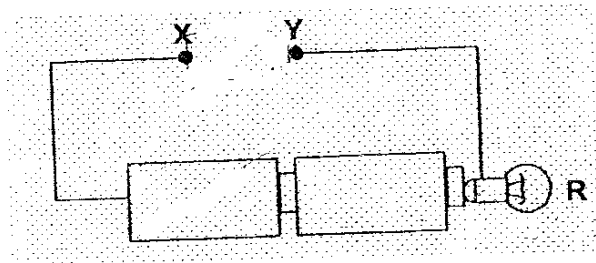

Which of the following can be used to join X and Y so that bulb R will light up?

- A: A magnet.
- B: An eraser.
- C: Another battery with the positive end at Y.
- D: A bulb with both X and Y connecting to its tip.

- (1) A and C only
- (2) A and D only
- (3) A, C and D only
- (4) A, B, C and D

23. Which one of the following does **not** help to conserve electricity?

- (1) Using energy-saving lamps.
- (2) Using fans instead of air-conditioners.
- (3) Switching off the lights on a bright day.
- (4) Leaving electrical appliances on standby mode when not in use.

24. Which one following graphs best shows the level of oxygen and carbon dioxide in the air in the garden over a period of 24 hours?

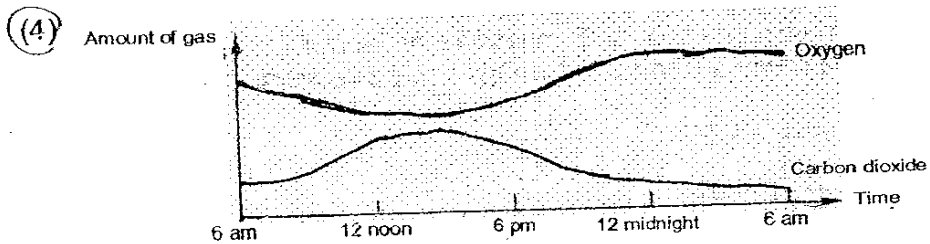
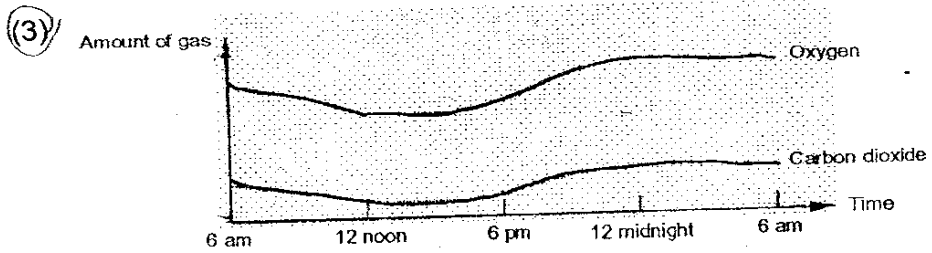
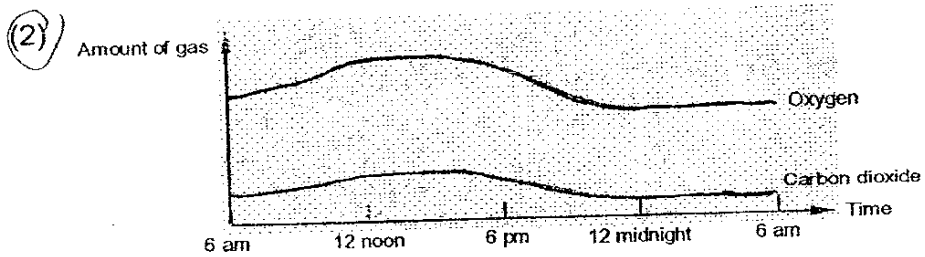
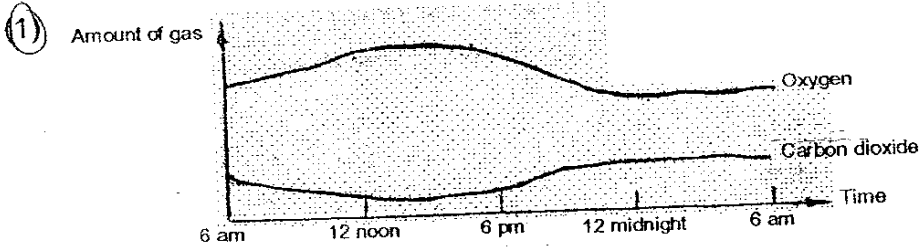

25. Ben wanted to find out if carbon dioxide is given off during respiration. He set up the experiment as shown below.

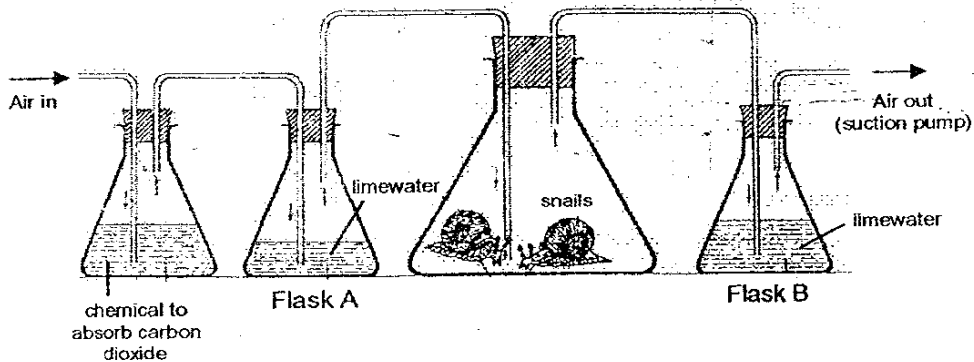

Which of the following observations would he make after 1 hour?

	Lime water in flask A	Lime water in flask B
①	Remained clear	Turned chalky
②	Turned chalky	Remained clear
③	Remained clear	Remained clear
④	Turned chalky	Turned chalky

26. What are the similarities between a caterpillar and a cockroach nymph?

- A: They are green.
 B: They have wings.
 C: They moult several times.
 D: They are insects.

- ① A and C
 ② A and D
 ③ B and D
 ④ C and D

27. Alan wanted to find out the volume of water taken in by a plant. He placed a plant in beaker A and set up beaker B as a control to ensure a fair test.

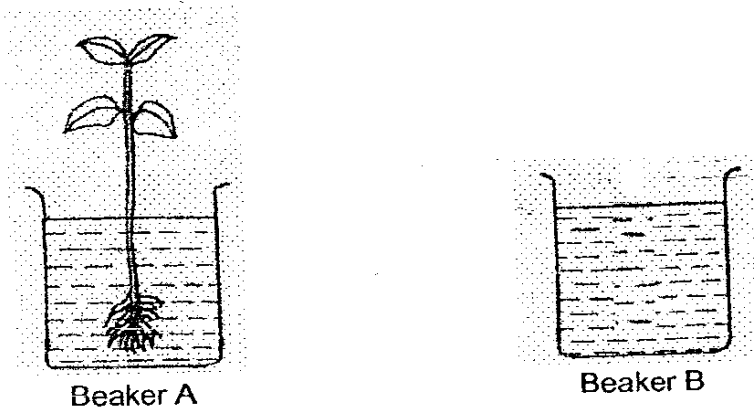

Beakers A and B were left in the open for 5 days.

The table below shows the volume of water in beakers A and B on Day 1 and Day 5 of the experiment.

Beakers	Volume of water (cm ³)	
	Day 1	Day 5
A	1000	850
B	1000	950

What was the volume of water taken in by the plant?

- ① 50 cm³
- ② 100 cm³
- ③ 150 cm³
- ④ 200 cm³

28. Study the diagram below carefully.

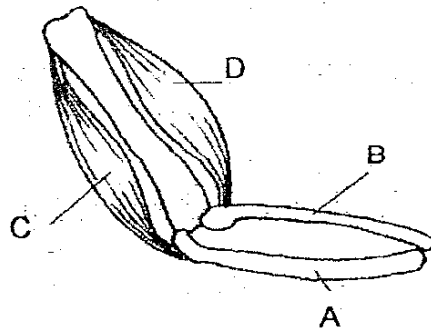

This is the bone and muscle structure of an arm. Which part will relax when we bend our arm?

- (1) A
- (3) C

- (2) B
- (4) D

29. A magnet wrapped in aluminium foil was lowered onto a trough of iron filings as shown in the diagram below.

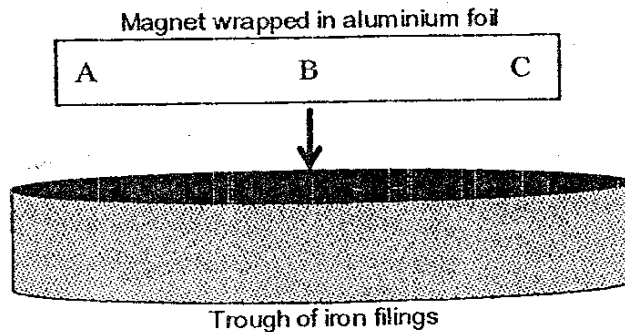

Which one of the following best shows the mass of iron filings attracted to the different parts, A, B and C, of the magnet, when the magnet is removed from the trough completely?

	Mass of iron filings (g)		
	A	B	C
(1)	0	0	0
(2)	4.3	1.3	1.3
(3)	4.9	4.3	4.4
(4)	4.7	0.2	4.6

607

30. Needle R is made into a temporary magnet by using the stroking method.

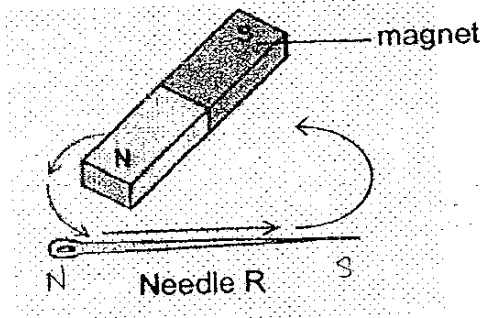

The needle is then placed near a compass. Which one of the needles shown is needle R?

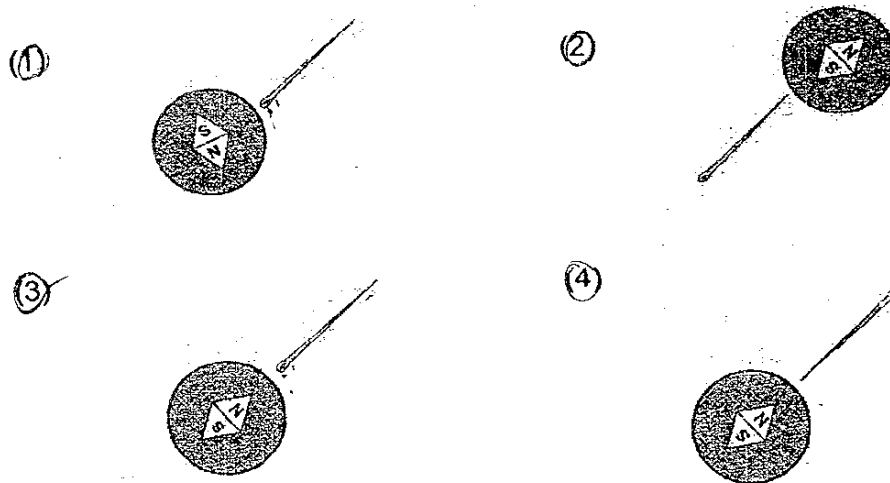

**NAN HUA PRIMARY SCHOOL
END OF YEAR EXAMINATION 2007
PRIMARY FIVE
SCIENCE**

Name : _____ ()

Class : Primary 5 / _____

MARKS	
	40

Section B: (40marks)

Write your answers to question 31 to 46.

The number of marks available is shown in brackets [] at the end of each question or part question.

31. Life exists on Earth but not on the other planets.

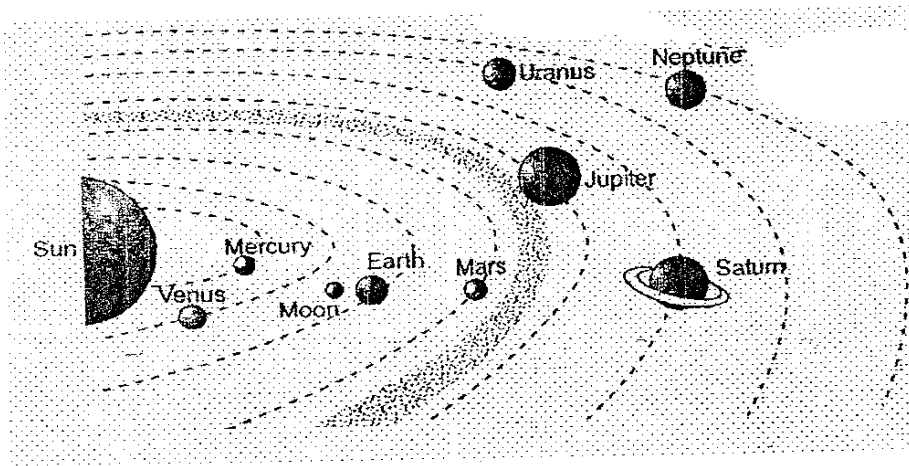

Give **two reasons** why life can exist on Earth. [2]

a) _____

b) _____

Score	
	2

32. Look at Victor's family tree shown below.

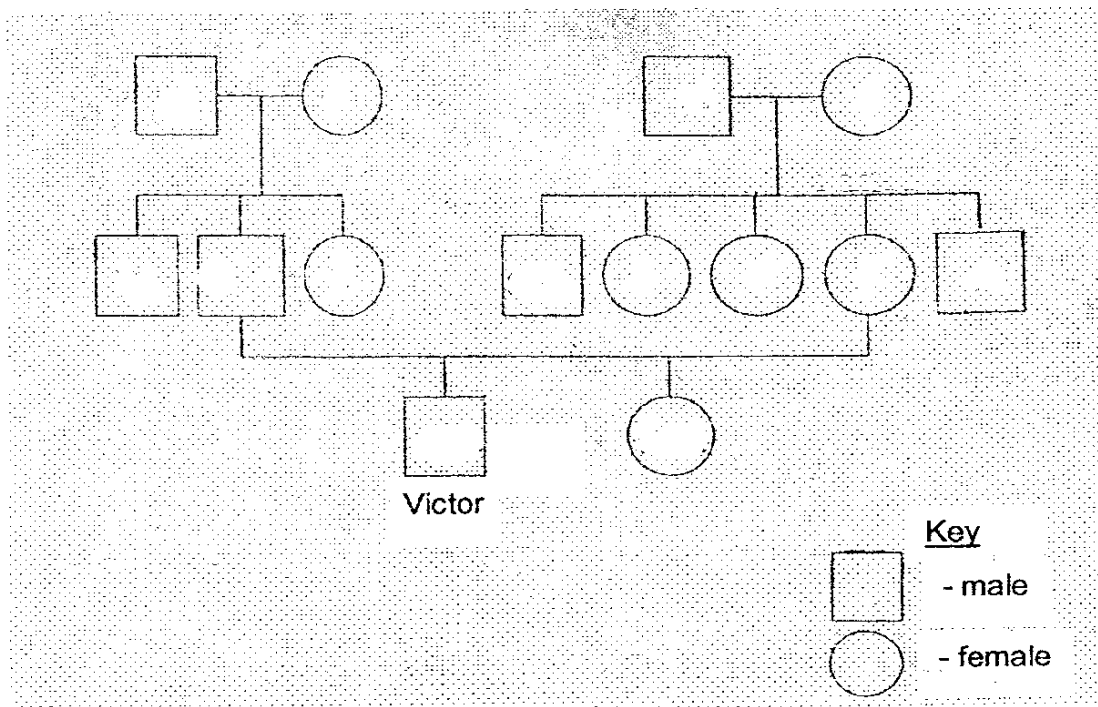

Based on the diagram, determine if the statements are "True", "False" or "Not possible to tell", by putting a tick (✓) in the correct column. [2]

	True	False	Not possible to tell
(a) Victor has only one sibling.			
(b) Victor has 3 aunts and 4 uncles.			
(c) Victor's paternal grandfather has 2 sisters and a brother.			
(d) Victor has many cousins as his uncles and aunts are all married.			

Score	2
-------	---

33.

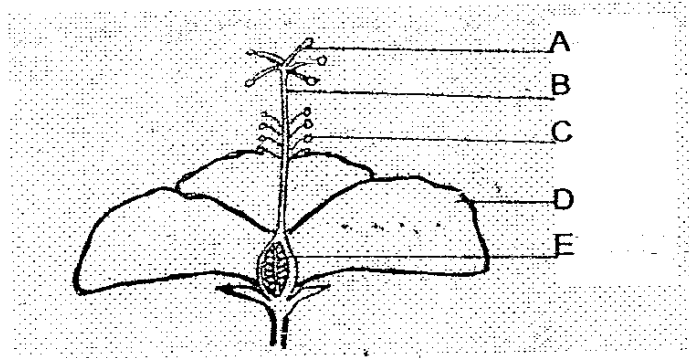

The diagram above shows a cross-section of a flower.

- (a) Which of these parts form the female reproductive system of the flower? [1]

- (b) Part D is often brightly coloured. Give a reason for this. [1]

- (c) Name the part that will develop into a seed after fertilisation has taken place. [1]

112

Score	3
-------	---

34. The diagram below shows an **incomplete** diagram of the internal parts of a bulb.

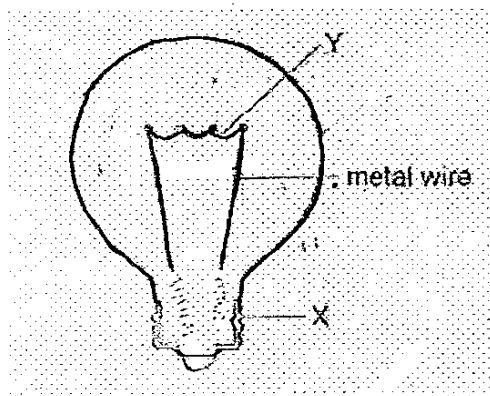

- (a) **Complete the diagram by drawing the metal wires to show how they are connected within the bulb.** [1]

- (b) **Name the following parts of the bulb:** [1]

X: _____

Y: _____

118

Score	2
-------	---

35. The six arrows in the diagram below show exchanges of gases between living things and their surroundings.

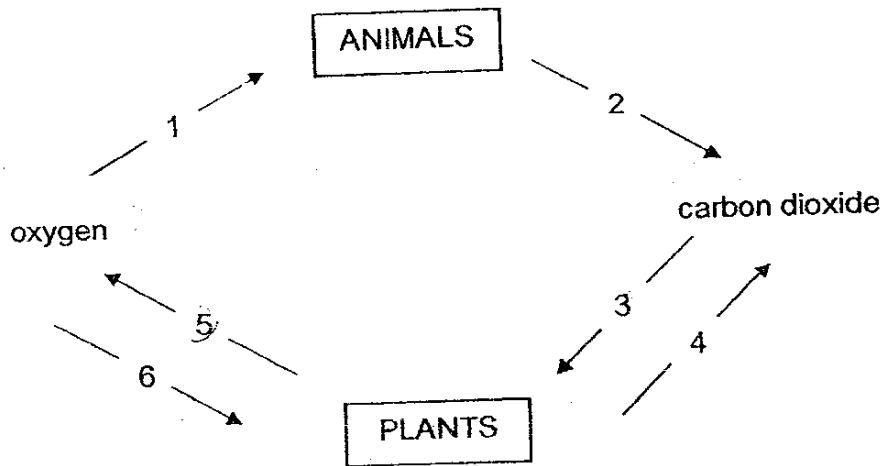

- (a) Which two arrows show the process of photosynthesis? [1]
-
- (b) Name 2 conditions **not** shown in the diagram that are necessary for photosynthesis. [1]
-
-
- (c) Name the product **not** shown in the diagram that is formed during photosynthesis. [1]
-

114

Score	3
-------	---

36. Look at the diagram below.
Fill in the names of the parts of the digestive system. [3]

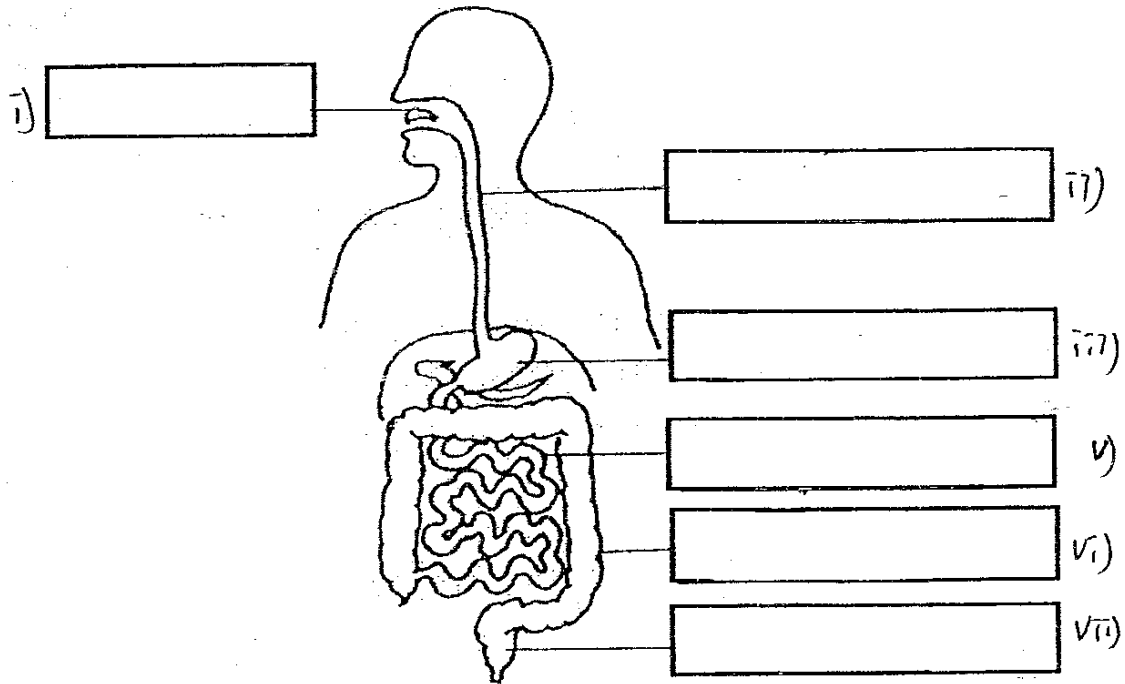

37. The diagram below shows a single cell organism undergoing reproduction.

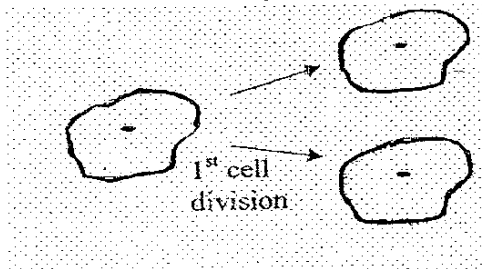

- (a) How many cells are there after the 4th cell division? [1]

- (b) Cell division occurs in both plants and animals. Why is it important for cells to reproduce? [1]

115

Score	5
-------	---

38. Study the banana plant shown below.

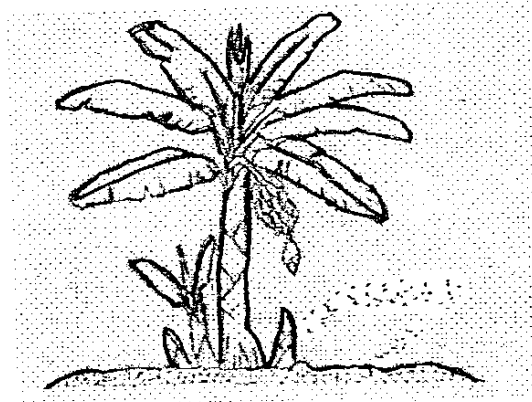

- (a) Use an **arrow** to indicate the sucker in the above diagram. [1]
- (b) What is the disadvantage of young banana plants growing so close together? [2]

Score	3
-------	---

39. A deliveryman used a plank to make an inclined plane to push a wheelbarrow of sand up to a truck. He pushed the wheelbarrow up the plank using 3 planks of different length as shown.

He then recorded the effort needed to push the wheelbarrow up the planks as shown in the table below. (Each '⚙' represents 1 unit of effort.)

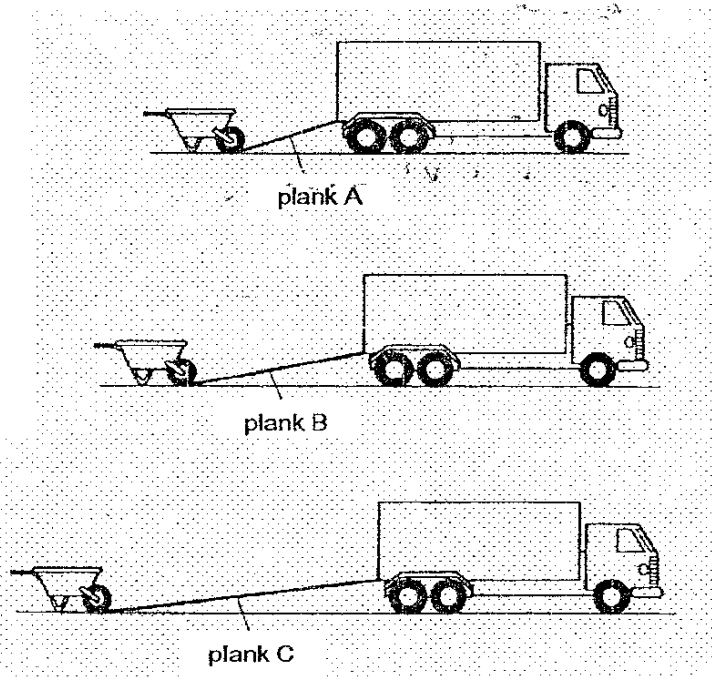

Plank	Effort needed
Plank A	⚙ ⚙ ⚙ ⚙ ⚙ ⚙
Plank B	⚙ ⚙ ⚙ ⚙
Plank C	⚙ ⚙

- (a) From the above experiment, what is the relationship between the length of the plank and the effort needed to push the wheelbarrow? [1]

- (b) Name one variable that the deliveryman had to keep constant in his experiment for it to be a fair test. [1]

117

Score	2
-------	---

40. An experiment was conducted using the pulley system shown below.

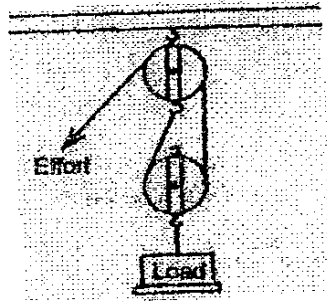

The effort needed to lift different loads was recorded in the following table.

Load (kg)	Effort needed (kg)
6	3.2
12	6.2
18	9.3
30	

- (a) Predict and write in the table above the effort needed to lift a 30kg load. [1]

- (b) State two advantages of using this pulley system. [2]

- (i) _____

- (ii) _____

Score	3
-------	---

41. The diagram below shows two batteries, two bulbs and a two-way switch. The two-way switch is made up of three thumbtacks, R, S and T, fixed on a piece of styrofoam. A paper clip is connected to S in such a way that it is free to turn about to touch either R or T.

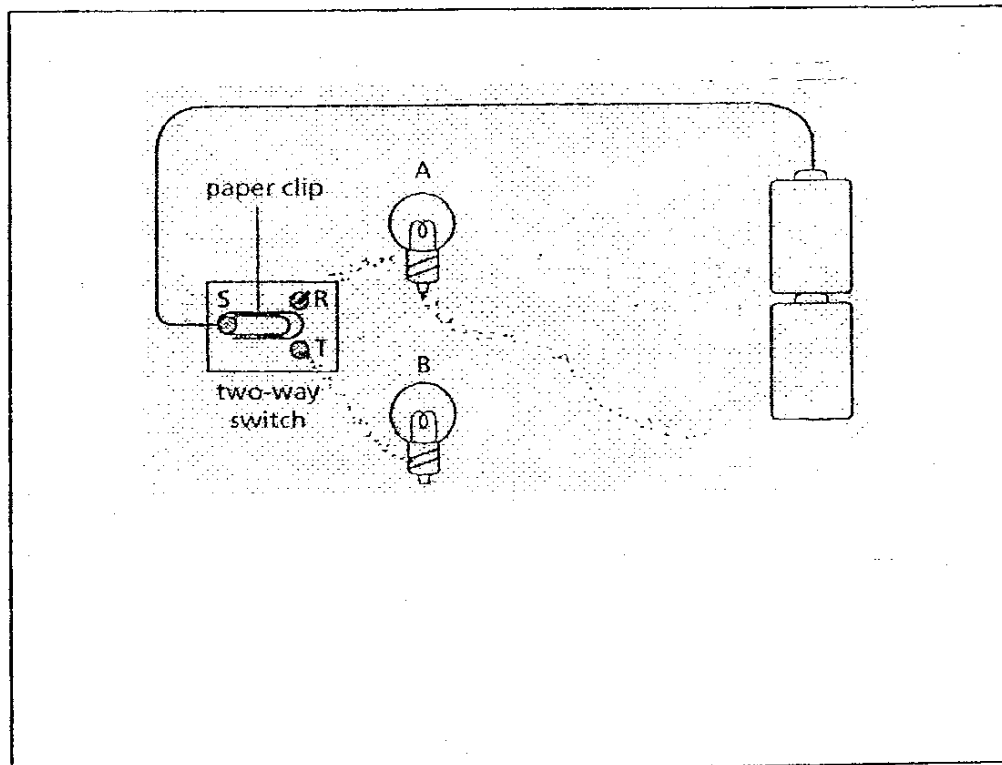

Draw in **wires** on the diagram to show how the bulbs and the two-way switch can be connected so that one can choose to light up either of the bulbs by moving the paper clip between R and T. [2m]

Score	2
-------	---

119

42. The diagram below shows a bulb and some batteries connected to three iron rods of different length.

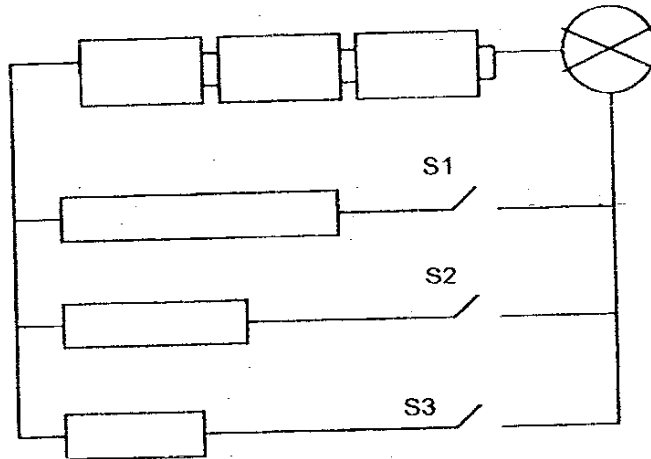

Kelvin closed switch S1 and kept switches S2 and S3 open. He then observed the brightness of the bulb. He repeated the experiment by closing switch S2 and keeping switches S1 and S3 open. Once again, he observed the brightness of the bulb. He did the same with switch S3. At any time, only one switch was closed.

What was Kelvin trying to find out in this experiment?

[2m]

Score	2
-------	---

43. Jamie set up an experiment to investigate the effect of different light intensity on the rate of photosynthesis.

She carried out her investigation as shown below.

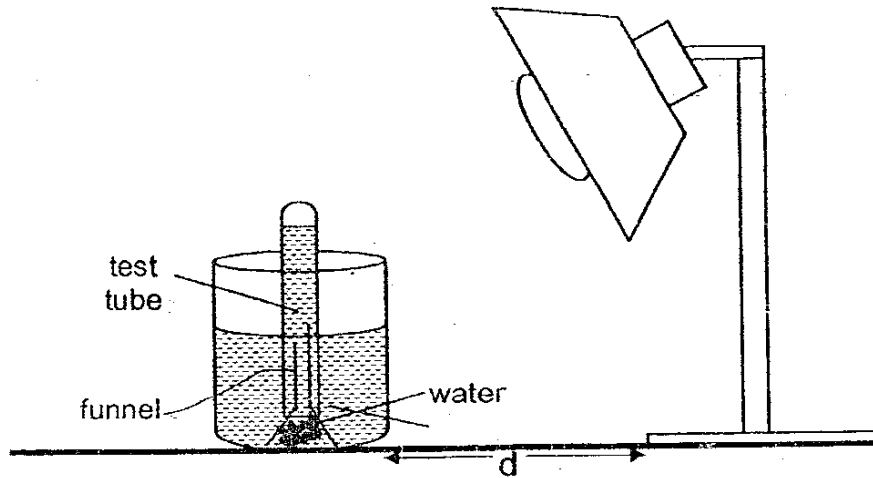

She changed "d", the distance between the lighted bulb and beaker and recorded the number of bubbles produced per minute at each position in the table below.

Distance between the lighted bulb and beaker / cm	40	35	30	25	20	15	10	5
Number of bubbles per minute	6	8	10	12	14	16	16	16

- (a) What conclusion can you draw from the results of Jamie's investigation?
[2]

Score	2
-------	---

- (b) On the axes below, draw a line graph to show the relationship between the number of bubbles per minute and light intensity. [2]

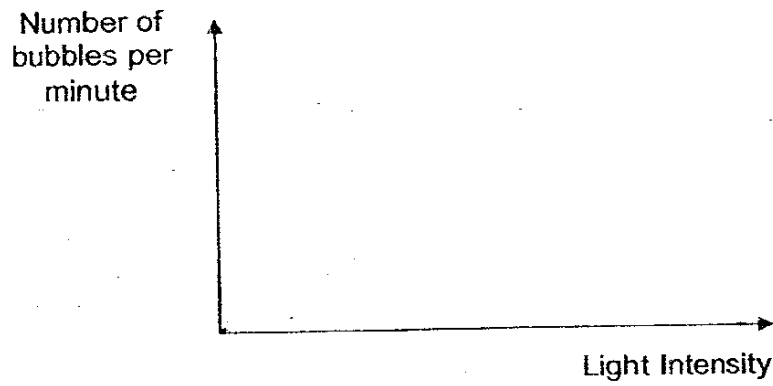

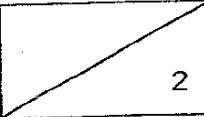
Score	
-------	---

44. Joseph cut different shapes out of pieces of black paper and used them to cover some leaves of a plant. After placing the plant under sunlight for some time, he conducted the starch test on the leaves. The first row shows the leaves after the starch test, with dark blue patches. The second row shows the pieces of black paper used to cover the leaves.

(a) Match each leaf to the correct piece of black paper used to cover it. [2]

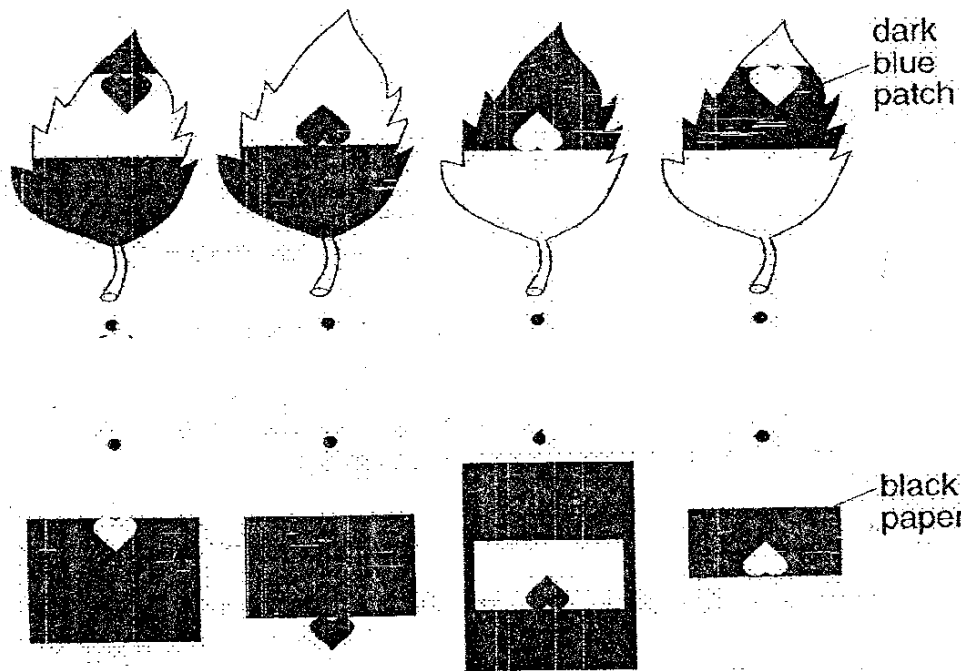

(b) What do the areas on the leaves where the iodine solution has turned dark blue contain? [1]

Score	3
-------	---

45. A group of pupils wanted to conduct an experiment to find out if different types of plants take in water at different rates. The following are the variables determined for the experiment.

(a) Duration of experiment	(b) Size of plants
(c) Amount of water	(d) Temperature of water
(e) Place of experiment	(f) Type of plants

Which variable(s) must change or remain the same?
Put a tick (✓) in the correct boxes below.

[2]

Variables	Change	Remain the same
Duration of experiment		
Size of plants		
Amount of water		
Temperature of water		
Place of experiment		
Type of plants		

Score	2
-------	---

46. Magnet A appears to be 'floating' above Magnet B.

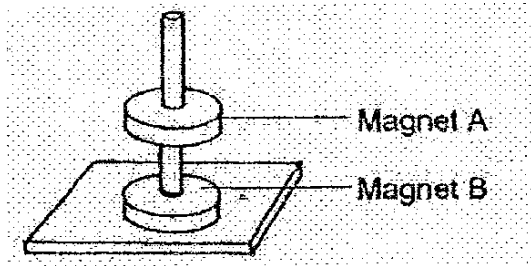

What causes Magnet A to 'float'?

[2]

END OF PAPER

Setter: Mr Kum CF

Score	2
-------	---

125

Nan Hua Primary School

Primary 5 Science SA2 Exams (2007)

Answer Keys

SECTION A : (60 MARKS)

Qn no.	Ans
1	4
2	2
3	4
4	3
5	4
6	2
7	2
8	4
9	3
10	3

Qn no.	Ans
11	1
12	2
13	2
14	4
15	3
16	4
17	1
18	3
19	4
20	2

Qn no.	Ans
21	1
22	3
23	4
24	1
25	1
26	4
27	2
28	3
29	4
30	4

SECTION B (40 MARKS)

- 31a. Earth has an atmosphere which contains oxygen, a gas that living things take in when they respire.
- 31b. Earth's position from the sun is just right so it is neither too hot nor cold for living things to stay alive.
- 32a. True
- 32b. False
- 32c. Not
- 32d. Not
- 33a. Part A, B and E.
- 33b. It is to attract insects to pollinate the flower.
- 33c. Part E (ovule).

34a.



- 34b. X : Metal casing
Y : Metal filament

- 35a. Arrows 3 and 5
 35b. They are sunlight and water.
 35c. The product is sugar.

36. (i) Tongue
 36. (ii) Gullet
 36. (iii) Stomach
 36. (v) Small intestine
 36. (vi) Large intestine
 36. (vii) Rectum

- 37a. There will be 16 cells. ($2 \times 2 \times 2 \times 2 = 16$).
 37b. Cell division occurs for growth and to replace old and damaged cells.

38a.

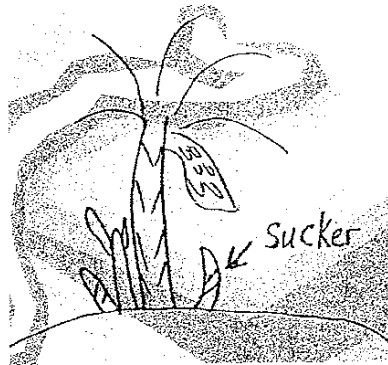

- 38b. Overcrowding may happen and young banana plants have to compete with each other for water, space, nutrient and sunlight and will not grow healthily.

- 39a. The longer the plank, the less the amount of effort is needed.
 39b. He had to keep the weight of the sand constant.

40a. 15.4

- 40b. (i) This pulley system change the direction of effort.
 (ii) This pulley system reduces the amount of effort needed to move a load.

41.

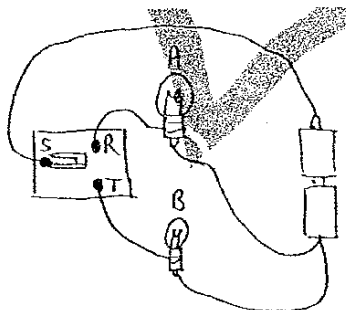

42. Kelvin was trying to find out if the length of the rod affects the brightness of the bulb.

43a. When the lighted bulb is nearer to the beaker, the intensity of the light is higher so the rate of photosynthesis of the plant is faster more bubbles are produced per minute. However, when the rate photosynthesis reaches a certain speed, the number of bubbles produced per minute will remain the same even if the intensity of the light is increased.

43b.

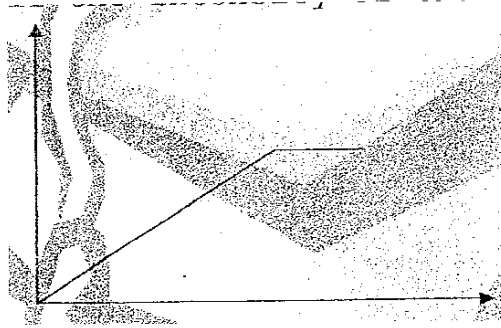

44a.

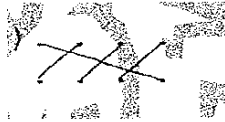

44b. They contain starch.

45.

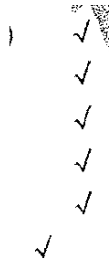

46. The like poles of Magnet A and Magnet B are facing each other, causing Magnet A to appear to "float" above Magnet B.