

Name : \_\_\_\_\_ ( )

Class : Primary 5 \_\_\_\_\_

## CHIJ ST NICHOLAS GIRLS' SCHOOL



Primary 5

Mid-Year Assessment

SCIENCE

BOOKLET A

16 May 2019

Total Time for Booklets A and B: 1 hour 45 minutes

28 questions

56 marks

Do not open this booklet until you are told to do so.  
Follow all instructions carefully.

This paper consists of 14 printed pages.



**Section A (28 x 2 marks = 56 marks)**

For each question from 1 to 28, four options are given. One of them is the correct answer. Make your choice (1, 2, 3 or 4). **Shade the correct oval (1, 2, 3 or 4) on the Optical Answer Sheet provided.**

1. Which of the following is a characteristic of mammals?

- (1) They lay eggs..
- (2) They have hairs on their body.
- (3) Their body is made up of three parts.
- (4) They breathe through their moist skins.

2. Study the classification table below.

Group A	Group B	Group C
rat	cow	lion
bear	goat	wolf
chicken	grasshopper	shark

The animals in the table above have been grouped according to \_\_\_\_\_.

- (1) what they eat ×
- (2) how they move ×
- (3) their body shape
- (4) their body covering

3. Which of the following is **not** true of our skeletal system?

- (1) It supports our body.
- (2) It gives our body shape..
- (3) It protects our lungs and heart.
- (4) It is made up of bones and muscles.

4. Penny constructed a small pond in her garden on Day 1.

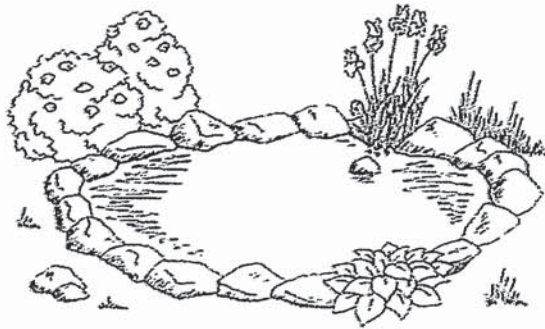

She observed 3 types of organisms, frog, butterfly and mosquito living in her garden. The number of days needed for their eggs to hatch is shown below.

Characteristic	Frog	Butterfly	Mosquito
Number of days needed for eggs to hatch	21	3	1

On Day 15, what would Penny most likely find in the pond?

- (1) frog eggs and butterfly larvae ✓
  - (2) mosquito larvae and tadpoles ✗
  - (3) frog eggs and mosquito larvae
  - (4) mosquito larvae and butterfly larvae
5. Quan Yi wanted to investigate if sunlight is needed for the germination of seeds. He sets up an experiment as shown below.

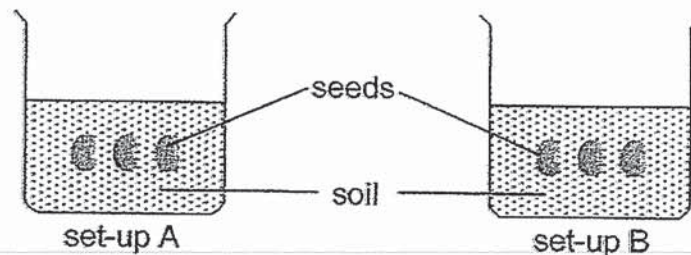

What are the variables that he must keep constant in order to make this experiment a fair test?

- A Amount of soil
  - B Presence of sunlight
  - C Temperature of the surroundings
  - D Amount of water added to the soil
- (1) A and B only
  - (2) B and C only
  - (3) A, C and D only
  - (4) A, B, C and D

6. The diagram below shows a plant cell taken from a leaf.

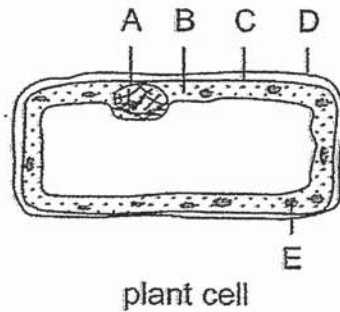

Which cell parts A, B, C, D and E can also be found in both root hair cells and cheek cells?

- (1) A, B and C only
  - (2) A, D and E only
  - (3) B, C and D only
  - (4) B, D and E only
7. The diagram below shows a panda.



Which of the following statements are true?

- A The panda is made up of many cells.
  - B All the cells in the panda are of the same size and shape.
  - C The cells in the panda contain genetic information from its parents.
  - D Each cell in the panda has a cell wall which gives the panda its shape.
- (1) A and B only
  - (2) A and C only
  - (3) B and D only
  - (4) B, C and D only
8. Which one of the following is true about the transport systems in humans and plants?
- (1) Both transport food.
  - (2) Both transport gases.
  - (3) Both contain an organ which pumps substances.
  - (4) Both have separate tubes for the transport of water and food.

9. Benny used a knife to cut away the outer ring of the stem at parts X and Y of a plant as shown below.

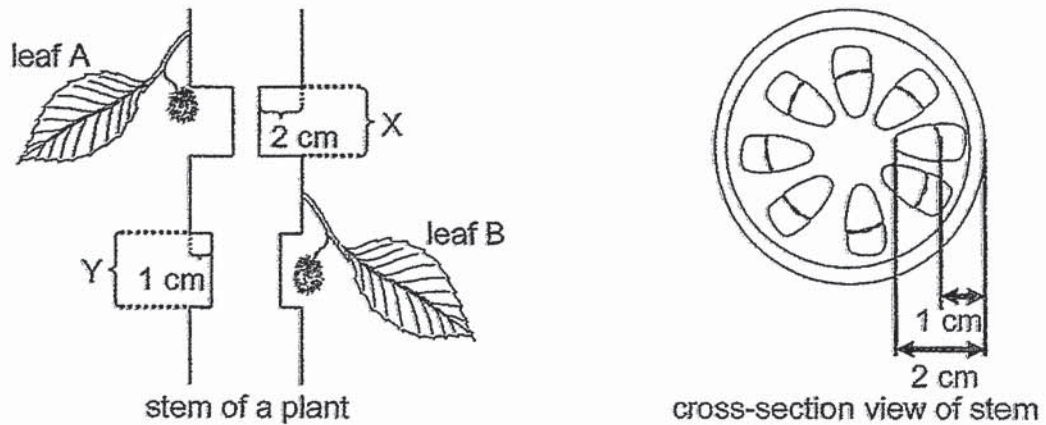

After one week, leaf A died but leaf B survived. Which one of the following best explains this observation? A tick (✓) indicates that the tubes are present while a cross (✗) indicates that the tubes are absent.

	At X		At Y	
	water-carrying tubes	food-carrying tubes	water-carrying tubes	food-carrying tubes
(1)	✓	✗	✓	✗
(2)	✗	✗	✓	✗
(3)	✗	✓	✗	✓
(4)	✗	✓	✗	✗

10. Study the diagram below.

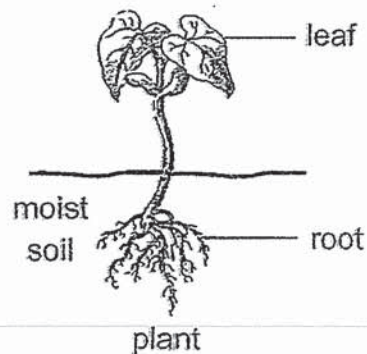

Which of the following shows the direction of transport of water and food between the leaf and the root?

	direction of transport of water	direction of transport of food
(1)	upwards only	downwards only
(2)	downwards only	upwards only
(3)	upwards only	upwards and downwards
(4)	downwards only	upwards and downwards

11. A group of coal miners were trapped in an underground cave. Which one of the following graph best represents the composition of gases in the air inside the cave after 2 hours?

(1)

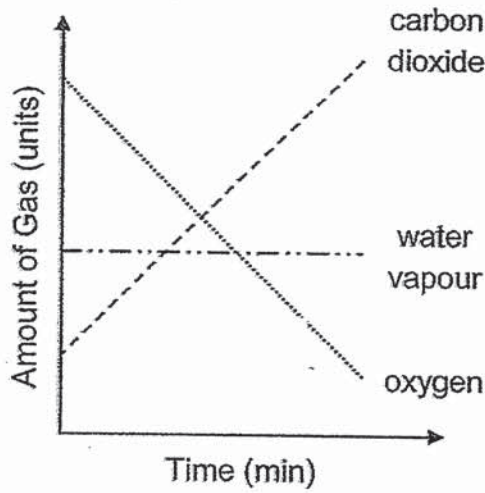

(2)

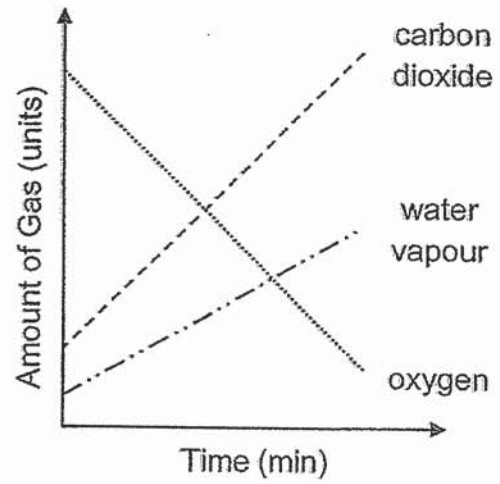

(3)

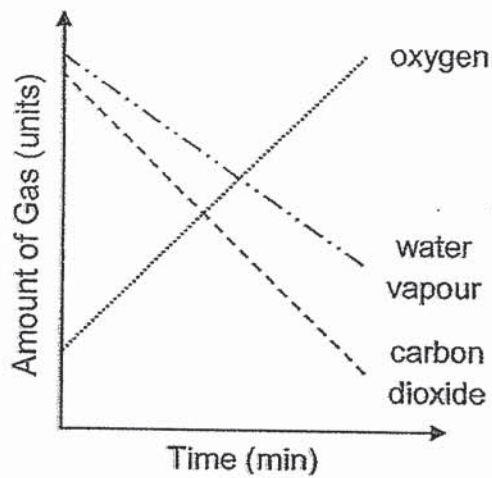

(4)

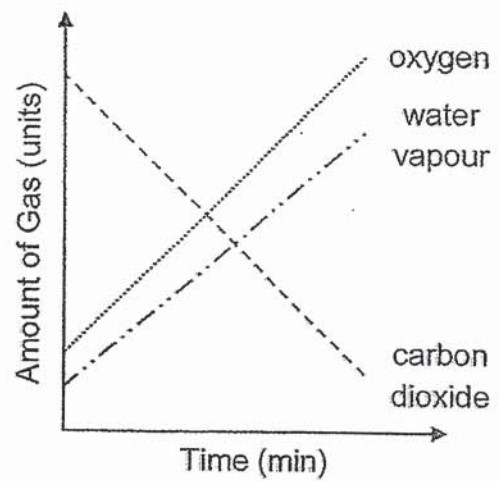

12. The diagram below shows a model of the human respiratory system. The movement of the model is similar to the movement of the parts in the human respiratory system.

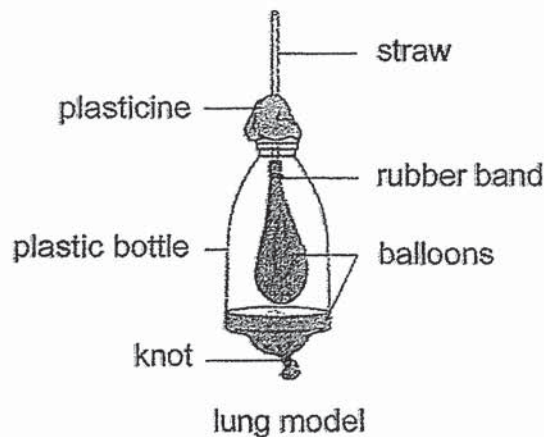

When the rubber sheet was pulled downwards, both balloons became inflated. Based on this observation, which of the following best describes the movement of the parts in the human respiratory system?

	movement of air	movement of diaphragm	size of lungs
(1)	into lungs	upwards	become smaller
(2)	into lungs	downwards	become larger
(3)	out of lungs	upwards	become smaller
(4)	out of lungs	downwards	become larger

13. The diagram below shows the direction of blood flow in some parts of the human body.

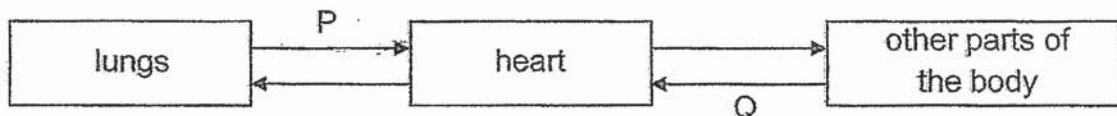

The bar chart below shows the amount of carbon dioxide in four blood samples taken from different blood vessels in the human circulatory system.

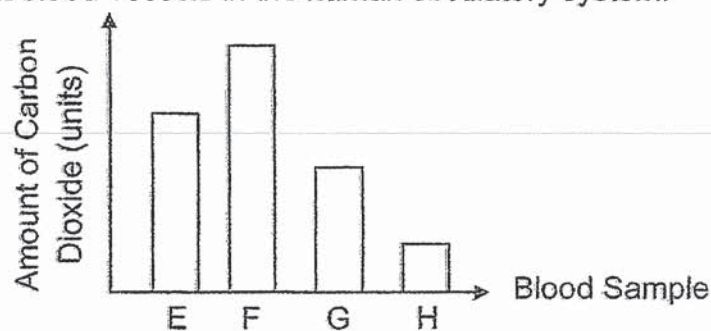

Which blood samples is likely to be taken from blood vessels P and Q?

	blood vessel P	blood vessel Q
(1)	F	E
(2)	F	G
(3)	G	H
(4)	H	E



14. Kavitha went for her morning exercise. From home, she took a slow walk to a nearby stadium and rested for a few minutes. Then she ran fast for two rounds around the track before resting at a nearby bench.

Which one of the following graphs best shows her heart rate from the time she left home to the time she rested at the bench?

(1)

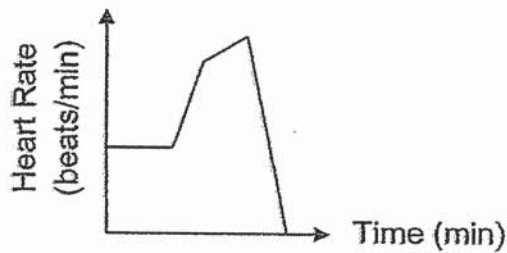

(2)

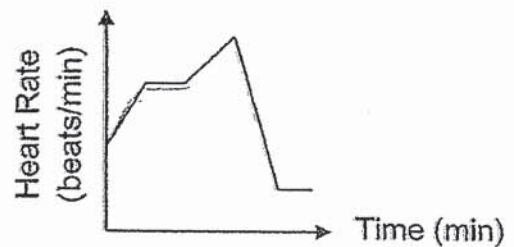

(3)

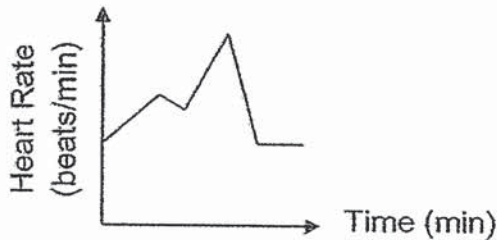

(4)

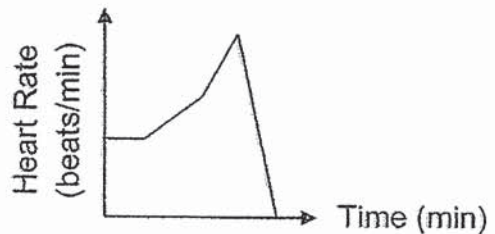

15. The diagram below shows a watch used by divers when they dive into the sea.

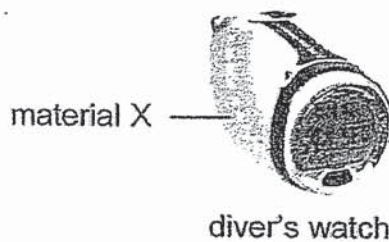

Which of the following properties are important when choosing material X for making the strap of the diver's watch?

- A Flexibility
- B Waterproof
- C Float in water
- D Allows light to pass through

- (1) A and B only
- (2) B and C only
- (3) A, B and D only
- (4) A, B, C and D

16. The diagram below shows how some examples of matter are classified.

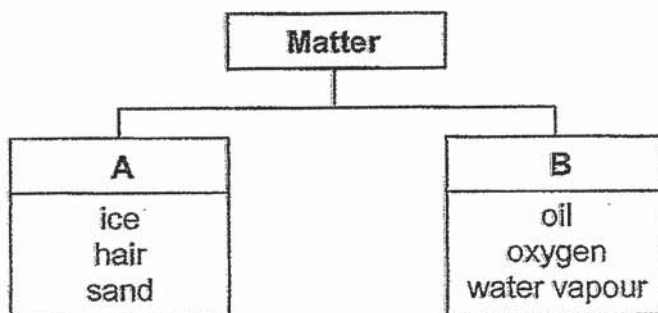

Which one of the following correctly represents A and B?

	<b>A</b>	<b>B</b>
(1)	has mass	has no mass
(2)	cannot be compressed	can be compressed
(3)	has definite shape	has no definite shape
(4)	has definite volume	has no definite volume

17. The table below shows the melting points and boiling points of substances W, X, Y and Z.

<b>Substance</b>	<b>Melting Point ( °C )</b>	<b>Boiling Point ( °C )</b>
W	36	55
X	32	85
Y	55	180
Z	10	66

Which of the substance(s) will be in the liquid state at 35 °C?

- (1) W only
- (2) W and X only
- (3) X and Z only
- (4) X, Y and Z only

18. Chong'Chai carried out the experiment below to demonstrate heat expansion in a solid. At room temperature, the iron ball could pass through the ring easily. After heating the iron ball at a very high temperature, the iron ball could not pass through the ring.

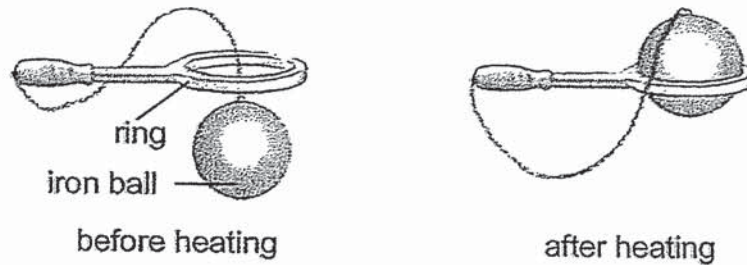

What had happened to the volume and mass of the iron ball after it was heated?

	Volume of the Iron Ball	Mass of the Iron Ball
(1)	no change	increase
(2)	increase	no change
(3)	increase	increase
(4)	no change	no change

19. The diagram below shows the interaction between different metal bars of equal size when they are hung on a horizontal wooden pole using strings.

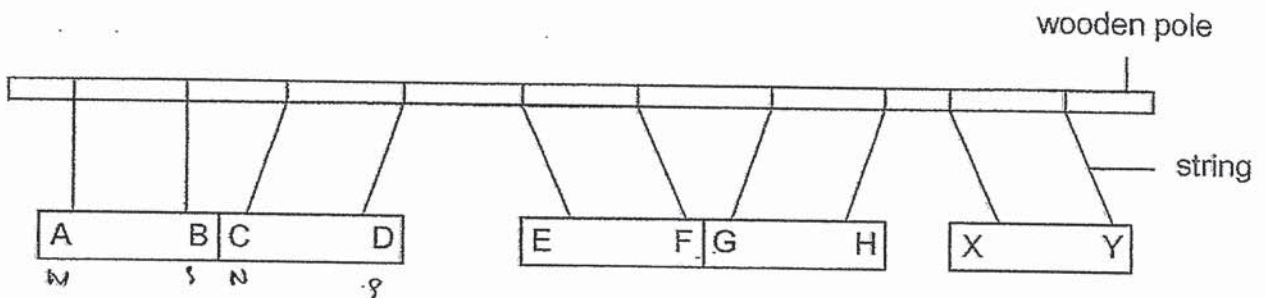

Based on the above results, which one of the following statements is **not** true?

- (1) B will repel D.
- (2) H will attract E.
- (3) D and E are like poles.
- (4) F and G are unlike poles.

20. A bar magnet was placed on a tray of iron filings and then lifted up to be placed on a table.

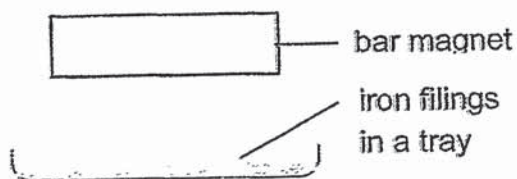

Which one of the following diagrams correctly shows the pattern of iron filings attracted to the bar magnet?

- (1) (2) (3) (4)

21. When Selvi held a glass of milk, she could see that it was white in colour because \_\_\_\_\_.

- A the milk reflected light  
 B the glass reflected light  
 C the milk allowed light to pass through  
 D the glass allowed light to pass through

- (1) B only  
 (2) D only  
 (3) A and D only  
 (4) B and C only

22. The experiment shown below was carried out in a dark room.

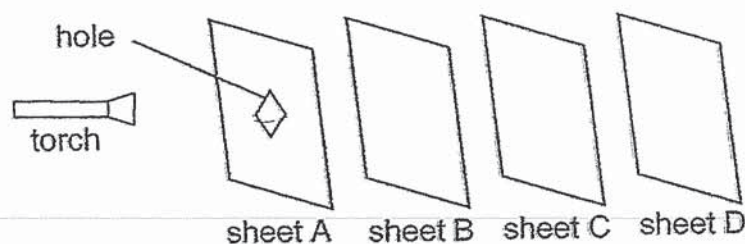

Sheets A, B, C and D were arranged in a straight line. When the torch was switched on, a bright diamond patch of light was seen only on sheet C. Which one of the following correctly describes the properties of the sheets?

	Allows light to pass through	Does not allow light to pass through	Not possible to tell
(1)	A and B	D	C
(2)	A and B	C	B
(3)	B	A and C	D
(4)	B	C	A and D

23. Three glasses A, B and C were each filled with the same amount of water. The temperature of water is different in each glass. After 15 minutes, water droplets were seen on B and C as shown below. No water droplets were seen on A.

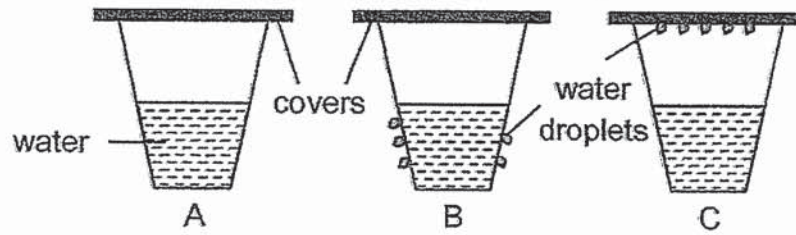

Which one of the following correctly shows the arrangement of the glasses based on the temperature of the water it holds?

	Highest Water Temperature	—————>	Lowest Water Temperature
(1)	A		C
(2)	B		C
(3)	C		B
(4)	C		A

24. The diagram below shows two glasses A and B, stuck together.

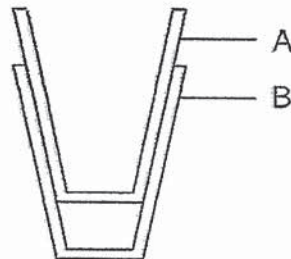

Linda was able to separate glass A from B.

Which one of the following most likely explains how she was able to do so?

- (1) She placed glass B into a basin of ice water.
  - (2) She placed both glass A and B into a basin of hot water.
  - (3) She poured hot water into glass A and placed glass B in a basin of ice water.
  - (4) She poured ice water into glass A and placed glass B in a basin of hot water.
25. Which one of the following is an example of using electricity safely?
- (1) Overloading a single electrical socket with too many plugs.
  - (2) Switching off all the fans and lights in the classroom when not in use.
  - (3) Turning off a switch before removing a plug from an electrical socket.
  - (4) Touching electrical components inside electrical appliances with your wet hands.

26. The diagrams below show the different arrangements of a battery, two bulbs and some copper wires. All electrical components are in working condition.

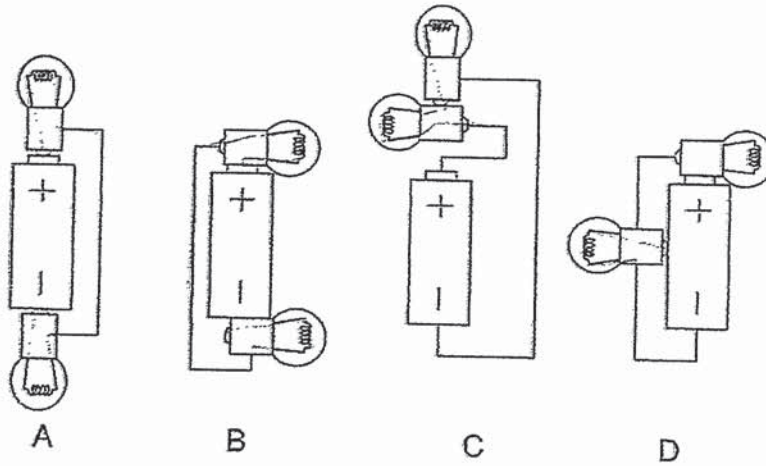

Which of the above arrangement(s) will enable **both** bulbs to light up?

- (1) A only
- (2) C only
- (3) A and C only
- (4) B and D only

27. The diagram below shows an electric circuit.

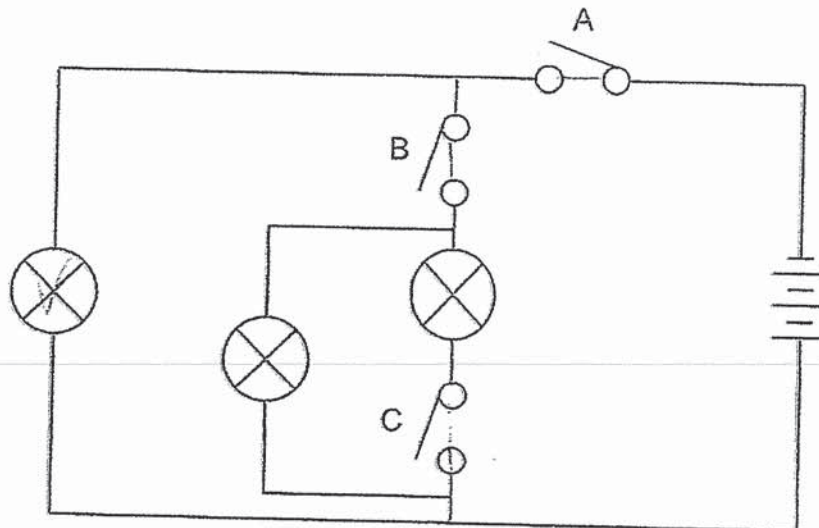

Which of the switch(es) must be closed so that only two of the bulbs light up?

- (1) A only
- (2) A and B only
- (3) B and C only
- (4) A, B and C only

28. Subhas connected two buzzers and four bars made of different materials P, Q, R and S as shown in the diagram below. A buzzer is an electrical component that produces a ringing sound when electricity flows through it. He recorded his observations in the circuit diagram below.

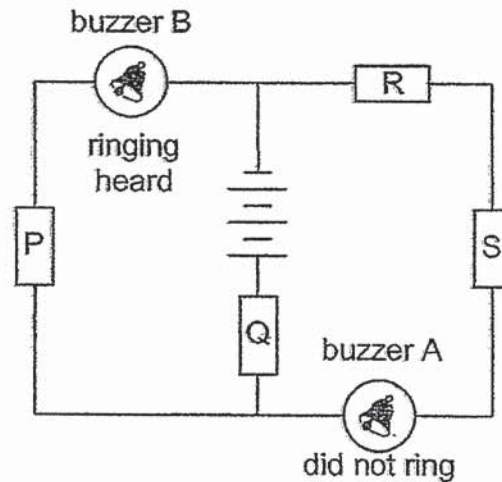

He later changed the positions of some of the bars and then recorded the new observations shown in the circuit below.

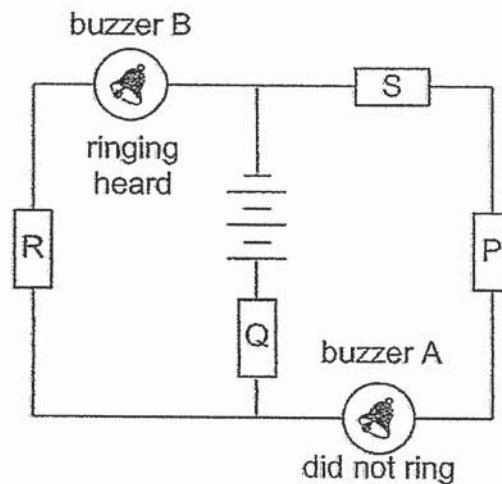

Based on the above observations, which of the following could P, Q, R and S most likely be made of?

	P	Q	R	S
(1)	Plastic	copper	steel	rubber
(2)	Steel	glass	wood	nickel
(3)	Nickel	copper	plastic	steel
(4)	Steel	nickel	copper	glass

END OF BOOKLET A

Name : \_\_\_\_\_ (     )

Class : Primary 5 \_\_\_\_\_

## CHIJ ST NICHOLAS GIRLS' SCHOOL



Primary 5

Mid-Year Assessment

SCIENCE

BOOKLET B

16 May 2019

Total Time for Booklets A and B: 1 hour 45 minutes

13 questions  
44 marks

Do not open this booklet until you are told to do so.  
Follow all instructions carefully.  
Answer all questions.

This booklet consists of 14 printed pages.

Booklet A	56
Booklet B	44
Total	100

\_\_\_\_\_  
Parent's Signature/Date



**Section B (44 marks)**

For questions 29 to 41, write your answers in this booklet. The number of marks available is shown in the brackets at the end of each question or part question.

29. May En studied the life cycle of organism Q shown below.

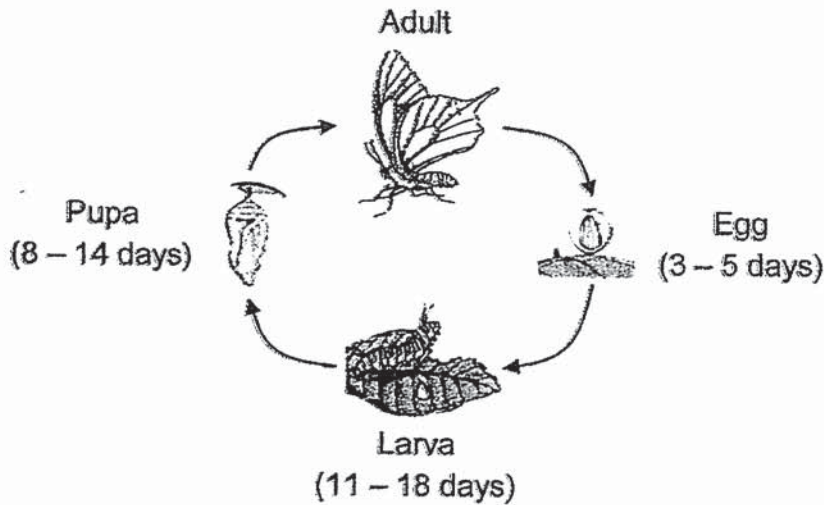

(a) May En classified organism Q as an insect. State one characteristic of the adult that helped her classify organism Q as an insect.

[1]

May En then studied the effect of the surrounding temperature on the life cycle of organism Q. She recorded her findings in the table below.

Stage	Duration	
	Number of Days (at 28°C)	Number of Days (at 22°C)
Egg	3	5
Larva	11	18
Pupa	8	14

(b) Based on her findings, how would the surrounding temperature affect the duration of one complete life cycle of organism Q?

[1]

(c) Some eggs of organism Q were found on the underside of some leaves. Suggest a reason for this observation.

[1]

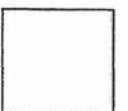

30. Halimah planted a green bean seed and recorded the mass of the seed leaves and the seedling over some time. She recorded her observations in the graph below.

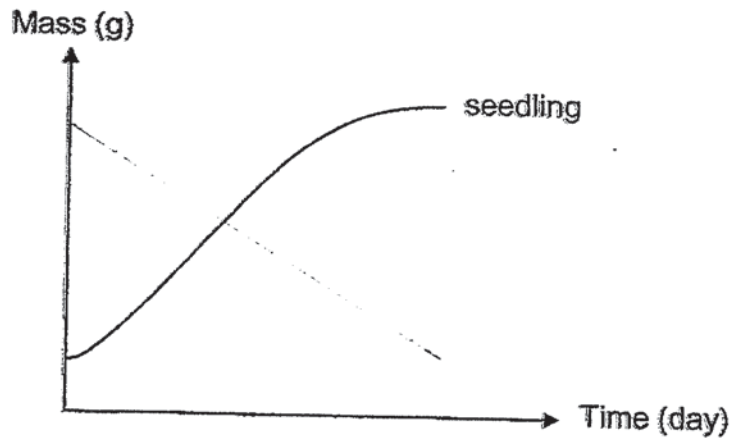

- (a) On the graph above, draw a **line** to indicate the change in the mass of the **seed leaves** as the young plant develops. [1]
- (b) Explain the change in mass of the seed leaves as the young plant develops. [1]

---



---



---

In another experiment, Halimah placed set-up A next to a window.

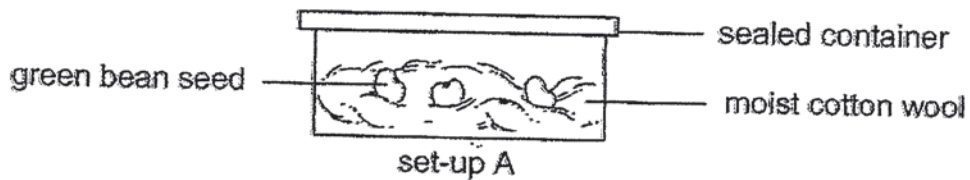

- (c) After one week, the seeds in set-up A did not germinate. Explain why. [1]

---



---



---



31. The diagram below shows a plant cell. After it was placed in water for an hour, the cell increased in size.

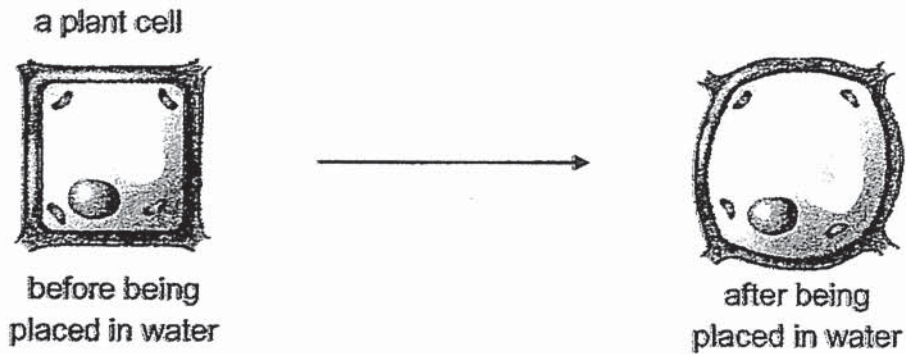

- (a) Which part of the cell is responsible for the change observed?  
Explain your answer.

[1]

---

---

---

- (b) Both Ai Lin and her mother have curly hair. Which part of the human cell contains the information that determines the type of hair Ai Lin has?  
Explain your answer.

[1]

---

---

---



32. Jean conducted an experiment in a classroom using the set-ups shown below.

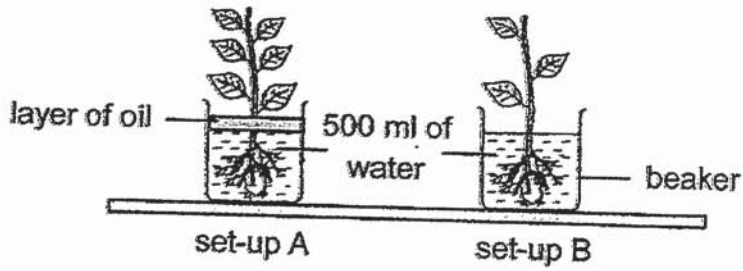

(a) State a reason why the experiment above is not a fair test. [1]

---

---

(b) State a possible aim of her experiment. [1]

---

---

Jean conducted another experiment with the set-ups shown below.

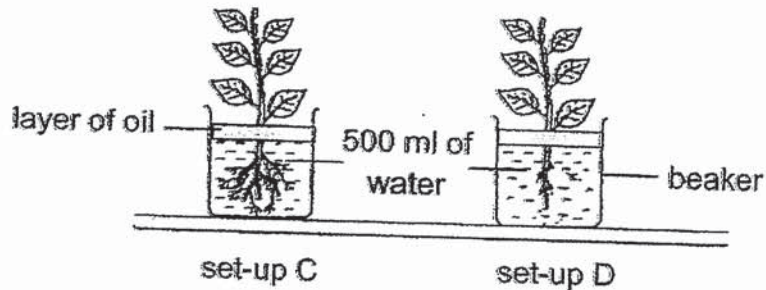

Both set-ups were placed near a window. After a few hours, she observed that the amount of water left in set-up C is much lower than in set-up D.

(c) Explain her observation. [2]

---

---

---



33. The diagram below shows a fish.

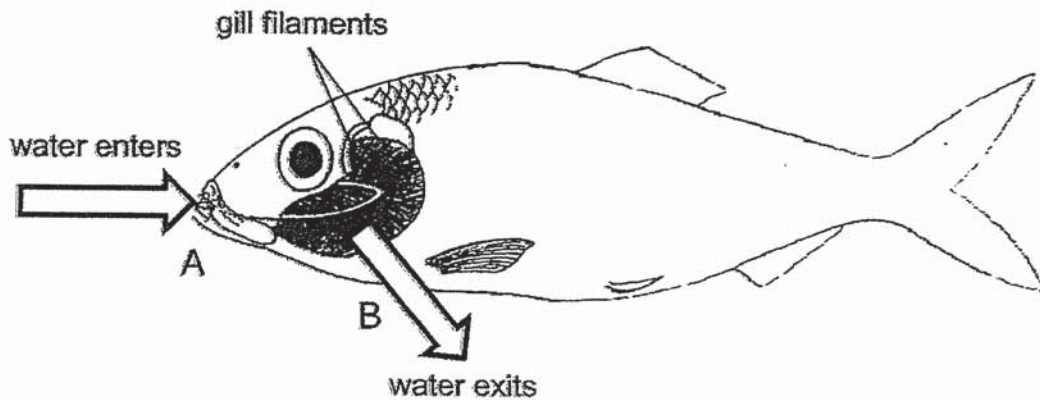

(a) Compare the amount of oxygen and carbon dioxide in the water samples at A and B. Then complete the table below with 'higher', 'lower' or 'unchanged' to show the differences.

Water Sample	Amount of Oxygen (cm <sup>3</sup> )	Amount of Carbon Dioxide (cm <sup>3</sup> )
at A		
at B		

[1]

[1]

The gill filaments of the fish are thin and have many blood vessels.

(b) Explain how the many blood vessels in the gill filaments help the fish in its gaseous exchange.

[1]

---



---



---

An experiment is conducted on two similar hamsters as shown below. Limewater turns chalky in the presence of carbon dioxide.

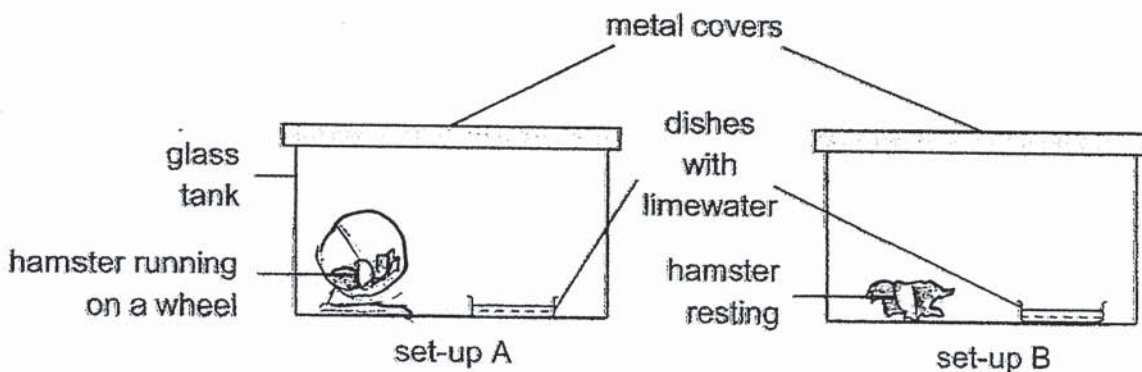

- (c) In which set-ups A or B, will the limewater turn chalky first? Explain your answer. [2]

---

---

---

34. Munirah placed two sheets of different materials P and Q into a basin of water as shown below. Both sheets floated on the water at first. After 30 minutes, sheet P remained floating on the water but sheet Q had sunk to the bottom of the basin.

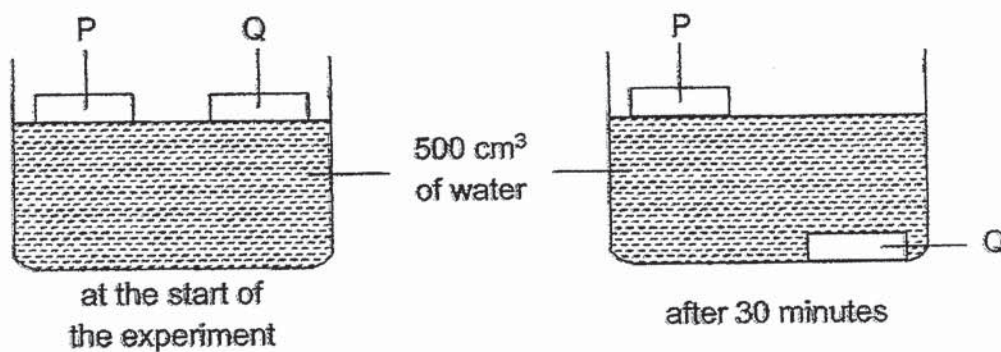

- (a) State a possible reason why sheet Q sunk to the bottom of the basin. [1]

---

---

- (b) State a property of sheet P based on the above observation. [1]

---

- (c) What must Munirah ensure before the start of the experiment in order to have a fair test? [1]

---

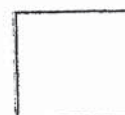

35. Kumar magnetised 3 identical iron bars A, B and C, using the stroke method. Each iron bar was given a different number of strokes with a magnet. The diagram below shows the maximum distance at which the iron bars would attract the steel paper clips.

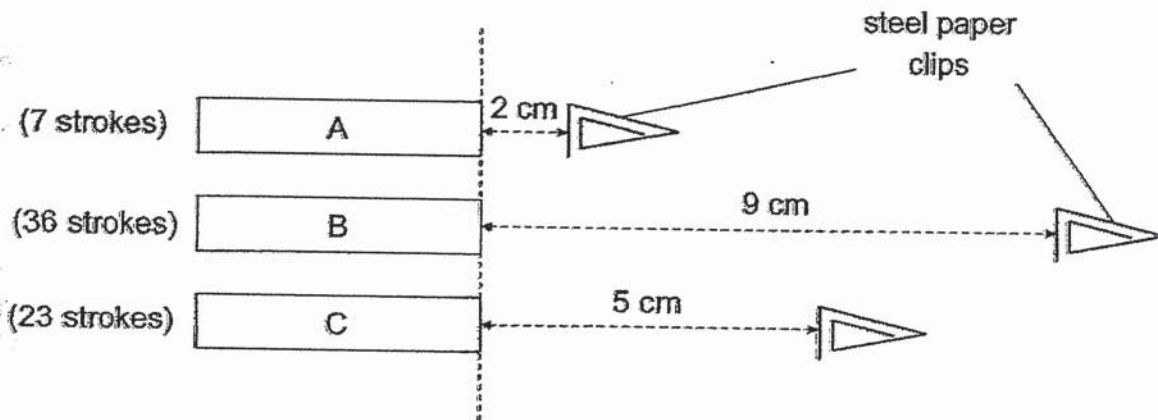

- (a) Which iron bar A, B or C has the greatest magnetic strength? Explain your answer. [1]

---



---

- (b) Based on the experiment, state the relationship between the number of strokes on an iron bar and its magnetic strength. [1]

---



---

Kumar accidentally dropped iron bar C and it broke into two pieces.

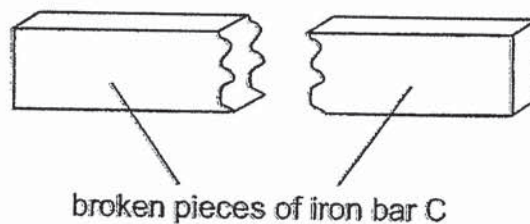

- (c) Will the broken pieces of iron bar C still be able to attract the steel paper clips? Give a reason for your answer. [1]

---



---

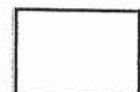

36. The diagram below shows two containers A and B containing  $100 \text{ cm}^3$  of fine sand and marbles respectively.

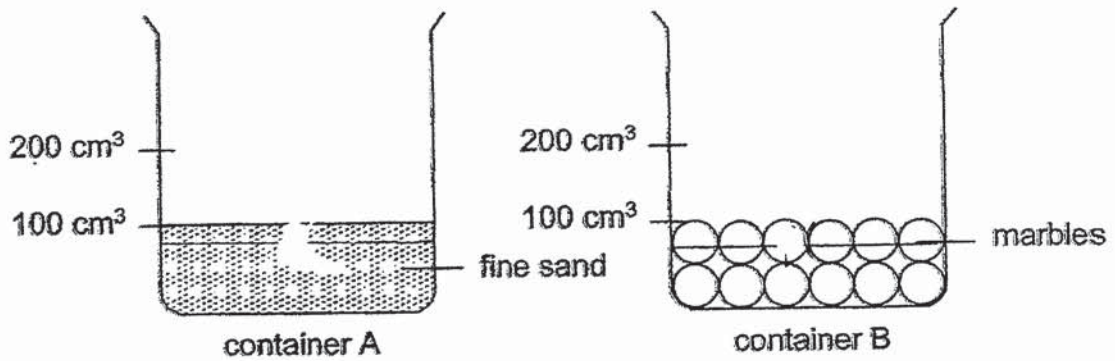

- (a) In the diagram above, draw the **water level** in the containers when  $100 \text{ cm}^3$  of water was added to both containers. [1]
- (b) Explain your answer for the difference in the water levels in (a). [2]

---



---

Hassan wanted to collect aluminium cans for the school's class recycling competition. He crushed the aluminium cans before placing them in a plastic bag as shown below.

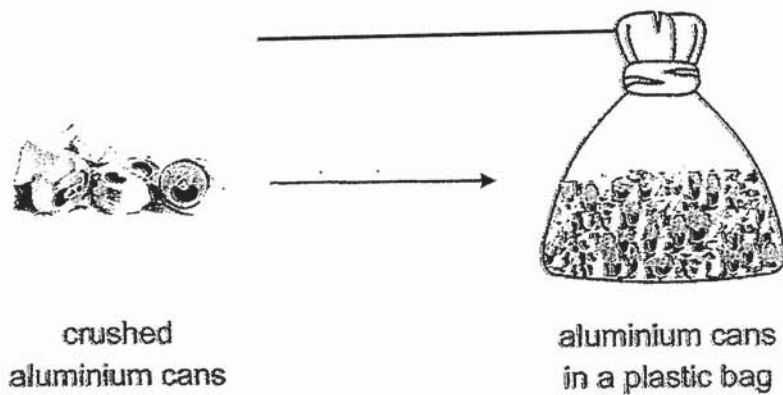

- (c) What could be the advantage of crushing the aluminium cans before placing them into the plastic bag? [2]

---



---



---





37. Harry placed two similar plastic bottles of water into two different buckets filled with the same amount of ice cubes as shown below.

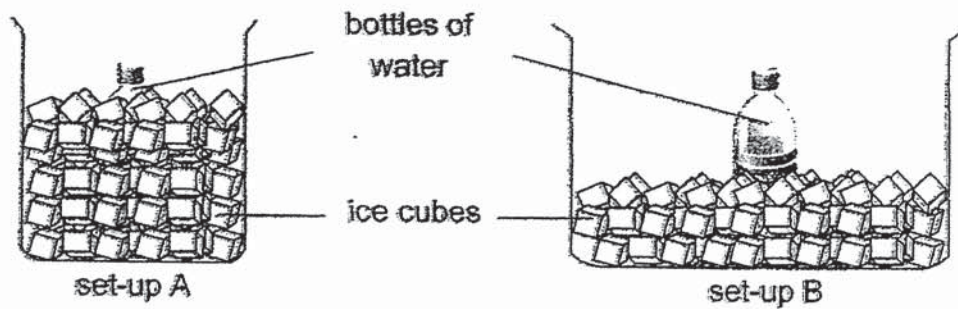

After 10 minutes, he recorded the temperature of the water in the bottles in the table below.

Time Recorded	Temperature of Water in Set-up A ( °C )	Temperature of Water in Set-up B ( °C )
at the beginning	27	27
after 10 minutes	15	22

- (a) Why is there a difference in the temperature of water in set-ups A and B after 10 minutes? [2]

---



---



---

- (b) Give a reason why Harry used two similar bottles of water for the set-ups. [1]

---



---

- (c) Harry repeated the experiment with two similar metal bottles of water. Will the temperature of water in these metal bottles be **lower**, **higher** or **remain the same** after 10 minutes compared to the results above? Explain your answer. [1]

---



---



---



38. Two identical empty glass bottles are connected by a glass tube containing a drop of red ink as shown below. The bottles are each placed in a container of water kept at a particular temperature.

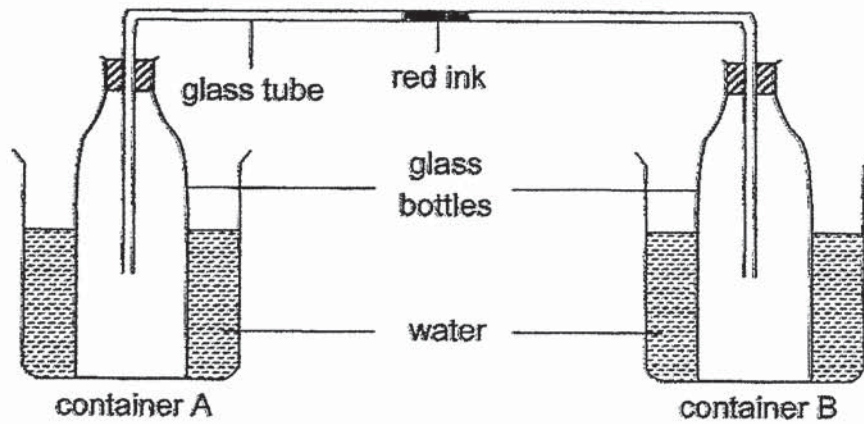

- (a) In the table below, put a tick (✓) in the correct box to show the direction of movement of the red ink for the following sets of temperature in each container. [1]

Temperature of Water ( °C )		Direction of Movement of Red Ink		
Container A	Container B	Red ink moves towards container A	Red ink does not move at all	Red ink moves towards container B
(i)	10	80		
(ii)	25	25		

- (b) State the reason for your answer in (ai). [1]

---



---



---

- (c) How does the temperature difference between the water in the two containers affect the distance moved by the drop of red ink? [1]

---



---



---



39. The diagram shows two cars P and Q travelling in the directions shown by the arrows.

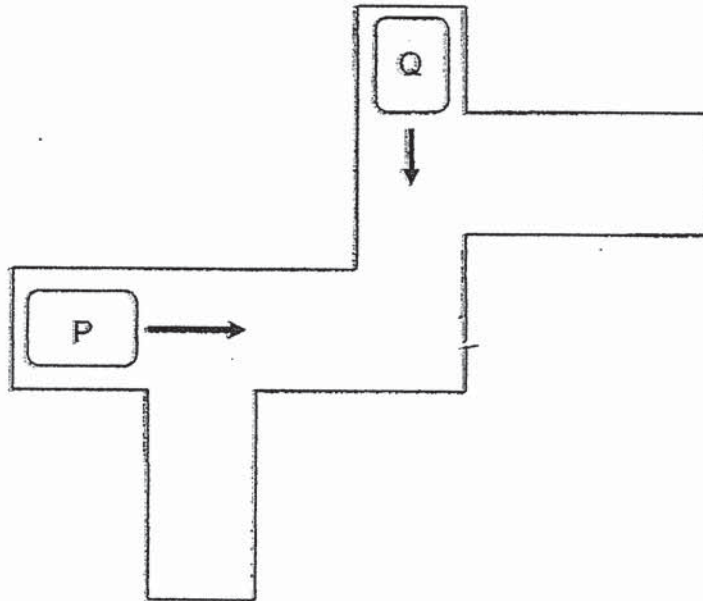

- (a) In the diagram above, **draw** and **label** where a **mirror** could be placed so that the drivers of cars P and Q can see each other. [1]

- (b) Write down two properties of light which make it possible for the drivers of cars P and Q to see each other. [2]

Property 1: \_\_\_\_\_

Property 2: \_\_\_\_\_

- (c) Would the drivers of cars P and Q be able to see each other clearly on a dark and cloudy day? Explain your answer. [1]

\_\_\_\_\_  
\_\_\_\_\_  
\_\_\_\_\_



40. The diagram below shows two circuits with three different bulb colours.

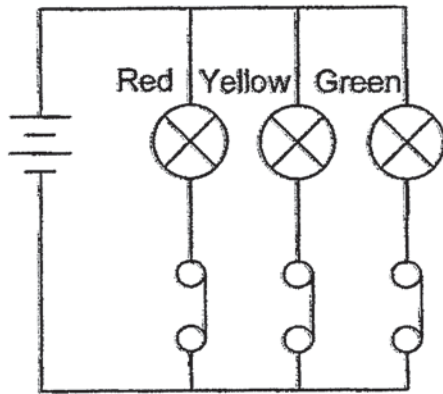

circuit A

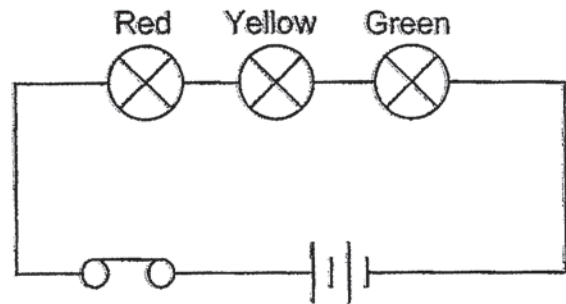

circuit B

- (a) Which circuits A or B will allow a traffic light to turn from green to yellow, then to red light? Explain your answer. [1]

---



---

- (b) How will the brightness of all the other bulbs change if one more bulb is added to both the circuits A and B above? [1]

Circuit	Effect on the brightness of other bulbs
A	
B	

- (c) Suggest one way to increase the brightness of the bulbs in **both** circuits. [1]

---



41. Toby used a circuit tester to test the connections on a circuit card as shown below.

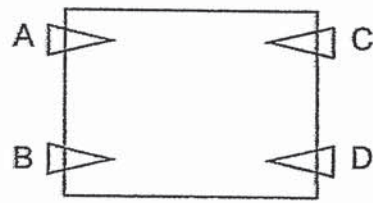

circuit card

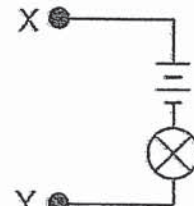

circuit tester

He then recorded the results in the table below.

Clips tested	Did the bulb light up?
A and C	Yes
A and D	Yes
B and C	No
B and D	No

Based on the results above, draw two possible connections on the circuit cards made by Toby.

[2]

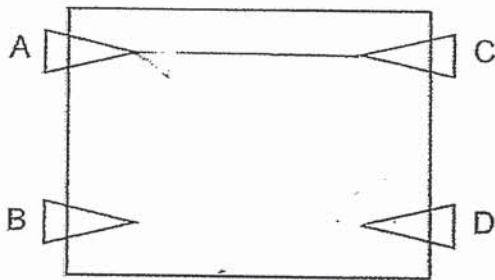

possible connection 1

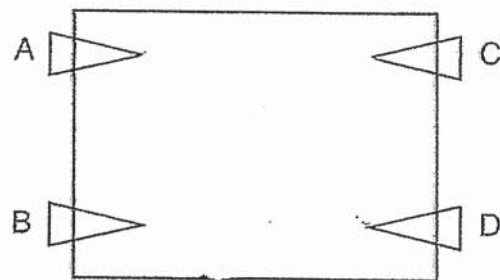

possible connection 2

END OF PAPER

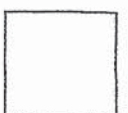



**EXAM PAPER 2019**

**LEVEL : PRIMARY 5**  
**SCHOOL : CHIJ ST NICHOLAS GIRLS' SCHOOL**  
**SUBJECT : SCIENCE**  
**TERM : SA1**

**BOOKLET A**

Q1	Q2	Q3	Q4	Q5	Q6	Q7	Q8	Q9	Q10
2	1	4	3	3	1	2	1	2	1
Q11	Q12	Q13	Q14	Q15	Q16	Q17	Q18	Q19	Q20
2	2	4	3	1	3	3	2	1	3
Q21	Q22	Q23	Q24	Q25	Q26	Q27	Q28		
3	3	3	4	3	3	2	4		

**BOOKLET B**

- Q29. a) The adult has three body parts.  
b) The colder the surrounding temperature, the longer the duration of one complete life cycle of organism Q.  
c) The organisms wanted to hide their eggs from predators or from being eaten.

Q30. a)

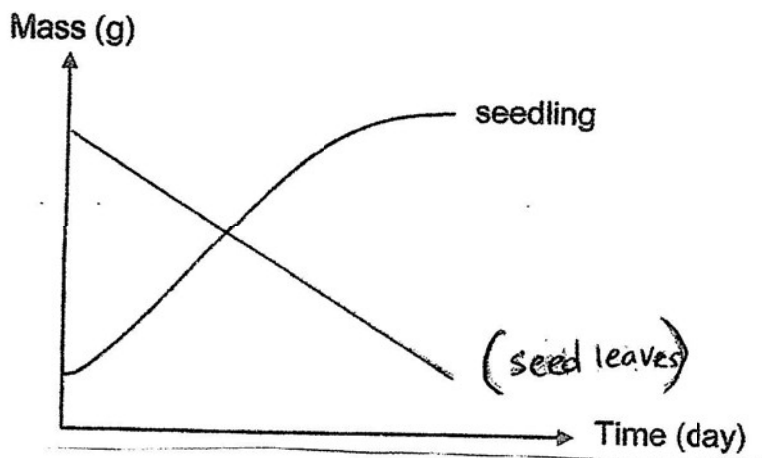

- b) The mass of the seed leaves will decrease as the food is used up by the growing young plant.  
c) Oxygen is needed for the seed in the container to germinate. The sealed container limits oxygen from entering the container.
- Q31. a) The cell membrane as it controls substances coming in and out of the cell, thus the cell membrane allowed water to enter the cell, making it bigger.  
b) The nucleus as it contains genetic information and can be passed down from previous generations, thus Ai Lin has curly hair like her mother.

- Q32. a) There is more than one variable changed which are the different number of leaves in each plant and the presence of a layer of oil in each set-up.  
 b) She wanted to find out if the number of leaves affected the amount of water taken in by the roots.  
 c) The plant in set-up C had more roots to absorb more water than the plant in set-up D

Q33. a)

Water sample	Amount of Oxygen	Amount of Carbon Dioxide
A	higher	lower
B	lower	higher

- b) The many blood vessels help to increase the surface area for gaseous exchange. This allows more oxygen for the dish to survive.  
 c) Set-up A. There is a higher rate of respiration in set-up A. Hence, more carbon dioxide is given out by the hamster in A.

- Q34. a) Sheet Q absorbs the water from the basin, thus making it heavier, causing the sheet to sink at the bottom of the basin.  
 b) It is waterproof.  
 c) The thickness of materials P and Q.

- Q35. a) B. It could attract the steel paper clip from the furthest distance.  
 b) The greater the number of strokes on an iron bar, the greater its magnetic strength.  
 c) Yes. The broken pieces of iron bar C still remained its magnetism.

Q36. a)

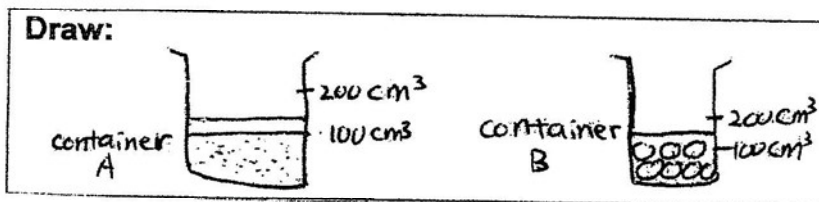

- b) There are lesser air spaces in between the fine sand grains in set-up A. Hence, a lesser amount of water occupies the space in between the fine sand grains.  
 c) It could reduce the amount of space it occupies in the bag and he put more cans in the bag.

- Q37. a) The bottle in set-up A has greater contact surface, so the water in the bottle loses heat faster to the ice.  
 b) To ensure that the volume of water is the same for both set-ups.  
 c) The temperature will be lower, metal is a better conductor of heat than plastic. Thus, water in the metal bottles will lose more heat to the ice cubes.



Q38. a)

Container A	Container B	Red ink moves towards container A	Red ink does not move at all	Red ink moves towards container B
10	80	✓		
25	25		✓	

- b) The air in the bottle in container B gained heat and expanded and pushes the red ink towards the bottle in container A.
- c) The greater the temperature differences the further distance moved by the red ink.

Q39. a)

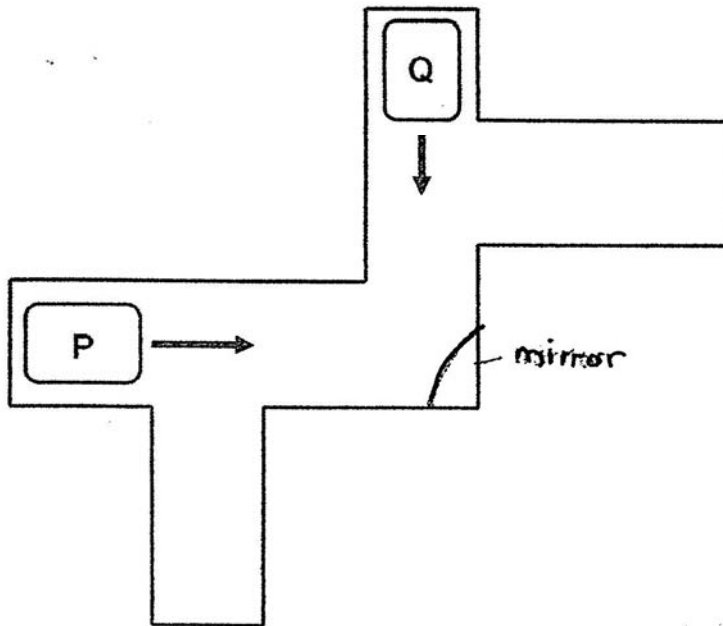

- b) **Property 1: Light travels in a straight line**  
**Property 2: Light can be reflected.**
- c) Yes. The driver can switch on headlights so light is reflected off the other car's mirror and into their eyes.

Q40. a) **Circuit A. The bulbs are connected in parallel and can be switched on and off individually.**

b)

Circuit	Effect on the brightness of other bulbs
A	Remain the same
B	Becomes dimmer

c) **Add more batteries.**

Q41.

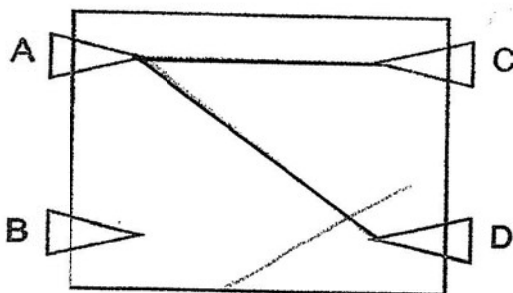

possible connection 1

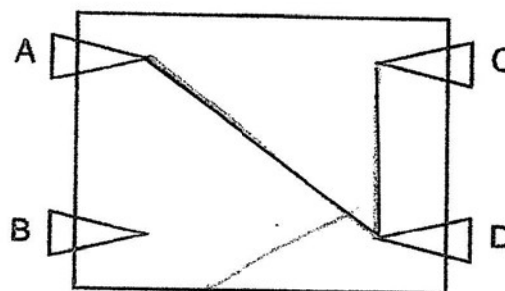

possible connection 2