



RED SWASTIKA SCHOOL

SCIENCE 2017 PRELIMINARY EXAMINATION PRIMARY 6

Name : _____ ()

Class : Primary 6/ _____

Date : 25 August 2017

BOOKLET A

Total time for Booklets A & B: 1h 45 min

Booklet A: 28 questions (56 marks)

Note:

1. Do not open the booklet until you are told to do so.
2. Read carefully the instructions given at the beginning of each part of the booklet.
3. Do not waste time. If the question is too difficult for you, go on to the next question.
4. Check your answers thoroughly and make sure you attempt every question.
5. In this booklet, you should have the following:
 - a. Page 1 to Page 25
 - b. Questions 1 to 28

SECTION A

For Questions 1 to 28, choose the most suitable answer and shade its number in the OAS provided.

1. The table below shows information on four plants, W, X, Y and Z, based on two characteristics. A tick (✓) shows that the plant has the characteristics.

Plant \ Characteristic	W	X	Y	Z
Bears fruit		✓	✓	
Grows in water	✓		✓	

From the information above, where do plants W, X, Y and Z, belong to in the following classification chart?

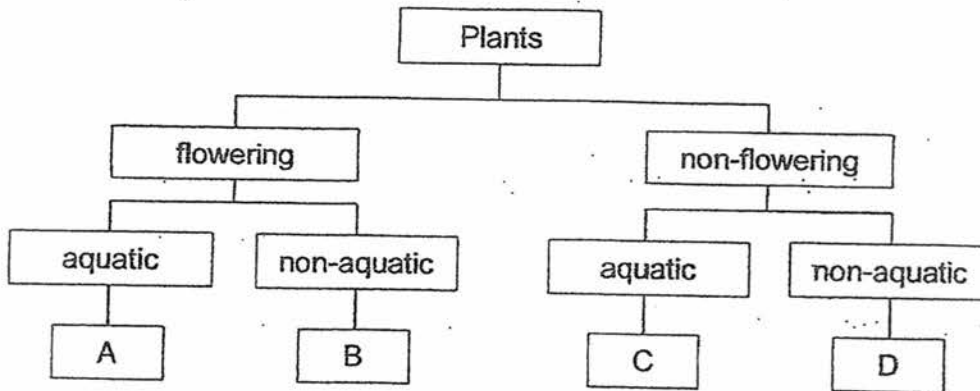

	Plant W	Plant X	Plant Y	Plant Z
(1)	D	B	C	A
(2)	C	A	B	D
(3)	A	D	C	B
(4)	C	B	A	D

2. The picture below shows some vegetables and weeds growing together in a vegetable farm.

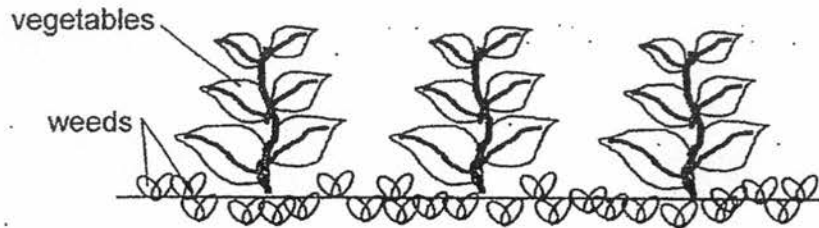

The vegetables compete with the weeds for _____
to grow well.

- A: air
- B: water
- C: space
- D: sunlight
- E: nutrients

- (1) C and D only
- (2) B, C, and E only
- (3) A, B, D and E only
- (4) A, B, C, D and E

3. Sam pasted four dry green bean seeds on a styrofoam board. The styrofoam board was then lowered into a container filled with cooled boiled water covered with a layer of oil as shown in the diagram below.

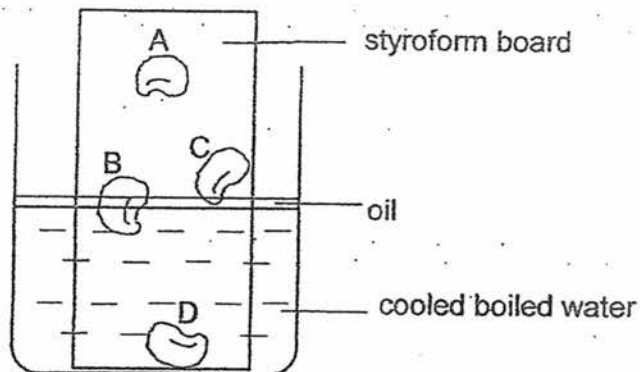

Which of the following seed(s) will likely germinate at the end of the week?

- (1) B only
 - (2) A and C only
 - (3) B and C only
 - (4) B and D only
4. The table below compares the sexual reproduction between humans and flowering plants.

	Human	Flowering plants
Male reproductive cell	A	B
Process whereby the female reproductive cell fuses with the male reproductive cell	C	D







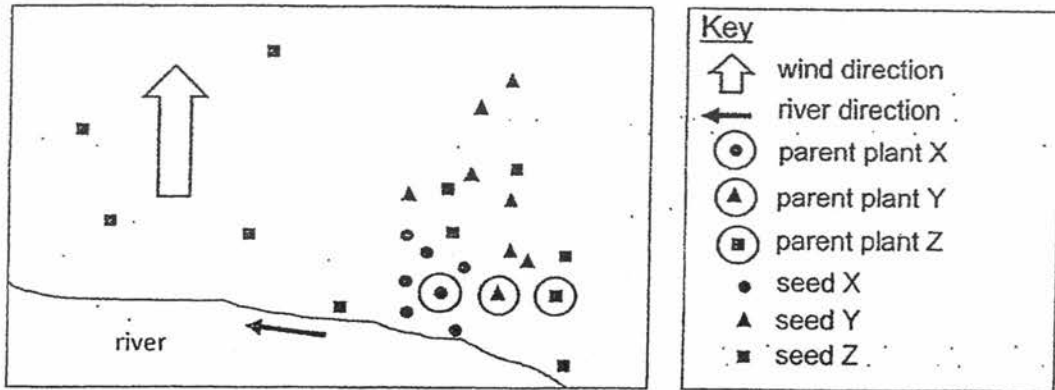



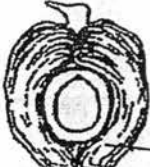

Which one of the following correctly identifies A, B, C and D?

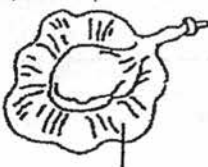
	A	B	C	D
(1)	Sperm	Pollen	Fertilisation	Pollination
(2)	Sperm	Pollen	Fertilisation	Fertilisation
(3)	Pollen	Sperm	Pollination	Pollination
(4)	Pollen	Sperm	Pollination	Fertilisation

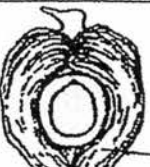
5. Study the distribution of seeds by plants X, Y and Z.

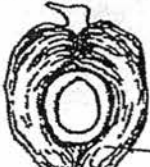

Which of the following correctly shows the fruits of plants X, Y and Z respectively?

	X	Y	Z
(1)	 wing-like structure	 pod-like structure	 fibrous husk
(2)	 pod-like structure	 wing-like structure	 hooks
(3)	 fibrous husk	 hooks	 pod-like structure
(4)	 hooks	 fibrous husk	 wing-like structure

6. The same amount of blood sample was taken from four different blood vessels in the body. The graph below shows the comparison of the amount of oxygen in the blood sample.

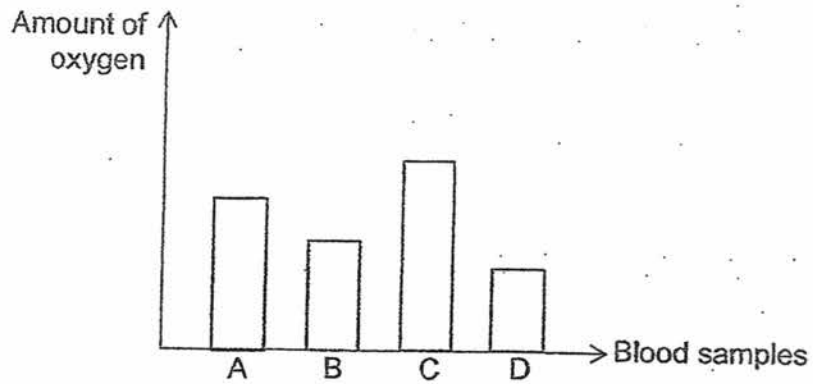

Which of the following correctly shows where the blood sample was taken from?

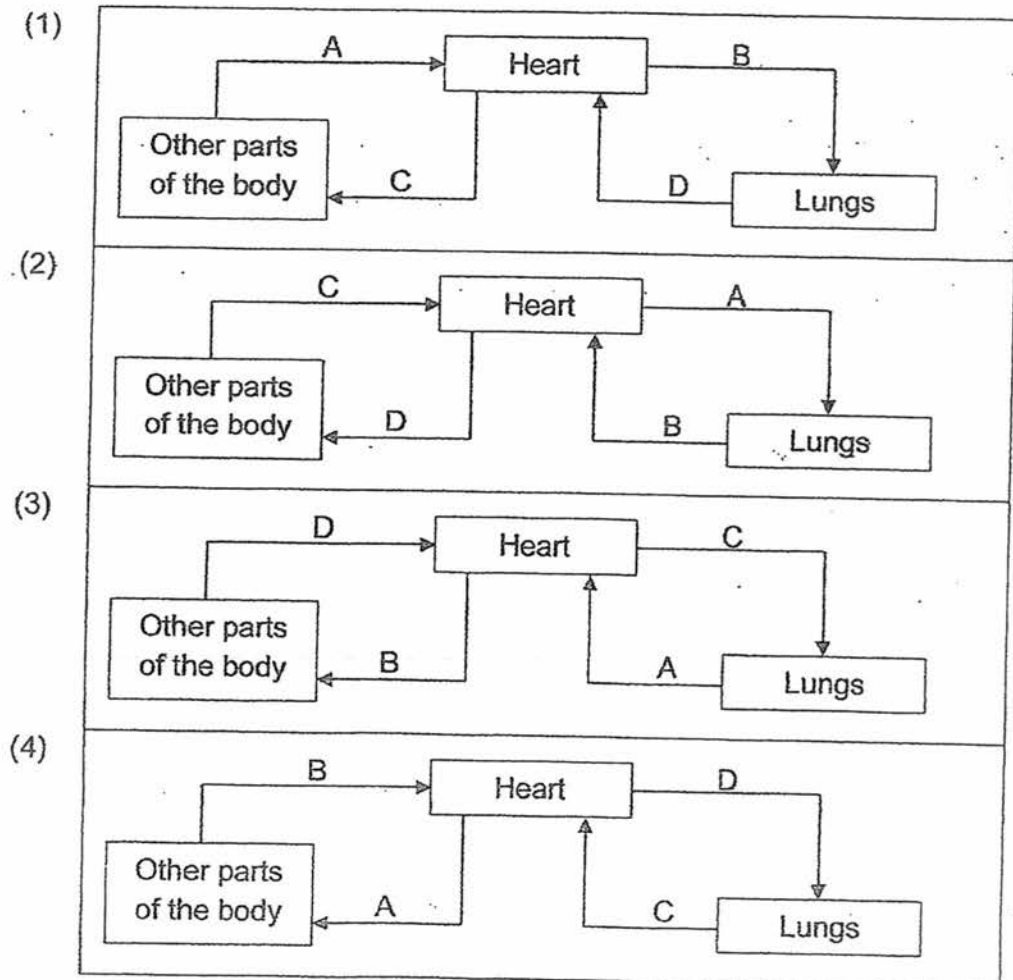

7. The diagram below shows the parts of plant A.

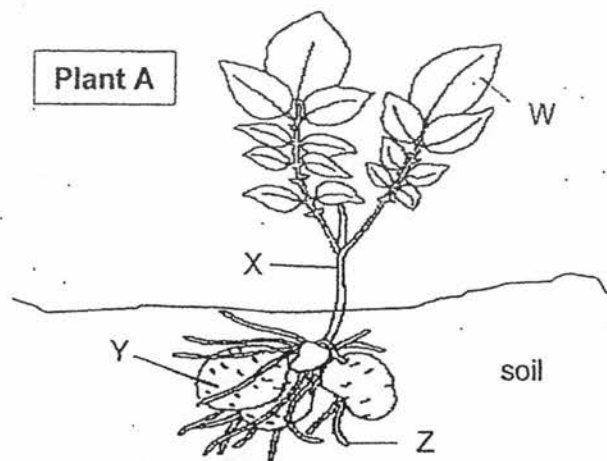

The cell below is taken from a certain part of plant A.

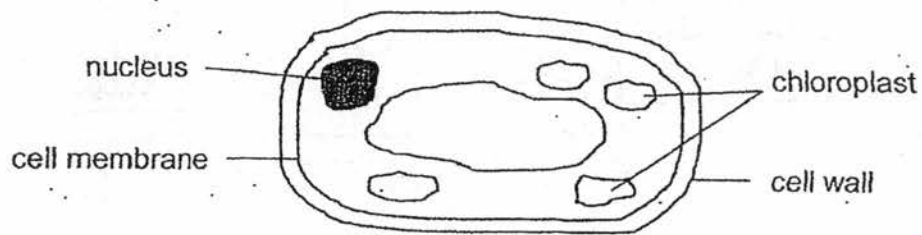

The cell is most likely from part _____ of the plant.

- (1) W
- (2) X
- (3) Y
- (4) Z

8. Study the three set-ups. At the start, substance X in each set-up was colourless. If the amount of carbon dioxide increases, substance X will change from colourless to chalky.

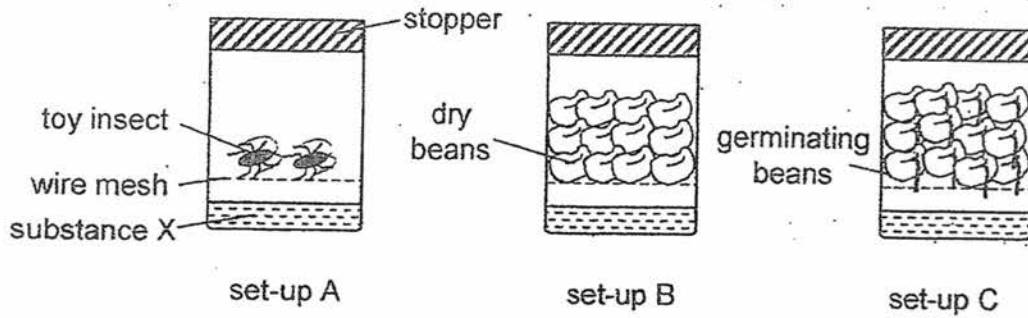

What is the colour of substance X in each set-up after 4 hours?

	set-up A	set-up B	set-up C
(1)	chalky	colourless	chalky
(2)	chalky	chalky	colourless
(3)	colourless	chalky	colourless
(4)	colourless	colourless	chalky

9. The table below shows the organisms that are found in a pond community and the food they eat.

Organism	Food
A	D
B	C
D	B, C

Which one of the following food webs shows the food relationship of the organisms?

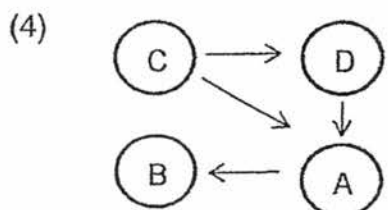
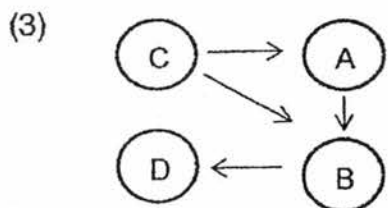
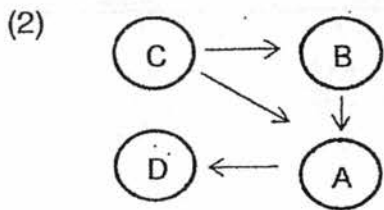
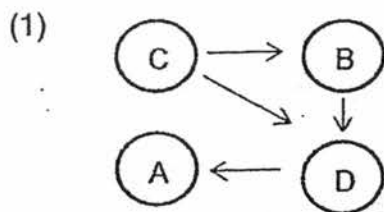

10. Study the food web below.

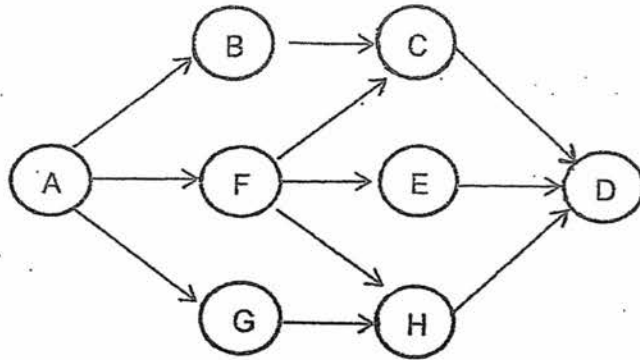

If the whole population of organism F is killed by a disease, which of the following population will likely decrease in number first?

- (1) A
- (2) C
- (3) E
- (4) H

11. Jamal wanted to find out the suitable living conditions for organisms X, Y and Z. In his container, there are four equal areas, P, Q, R and S, with different conditions as shown below.

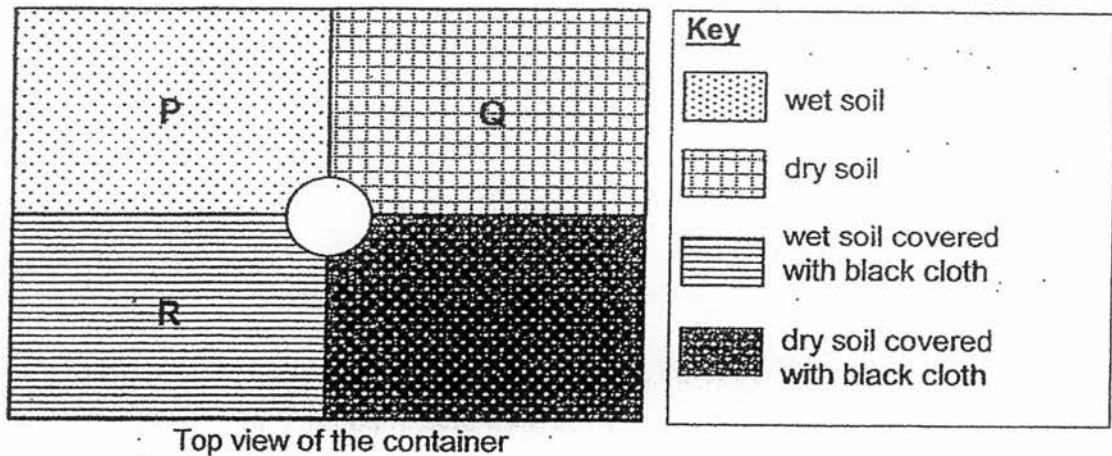

The same number of organisms, X, Y and Z, were placed in the dish in the centre of the container at the beginning of the experiment. At the end of the experiment, the total number of organisms in each area was counted and recorded in a bar chart below.

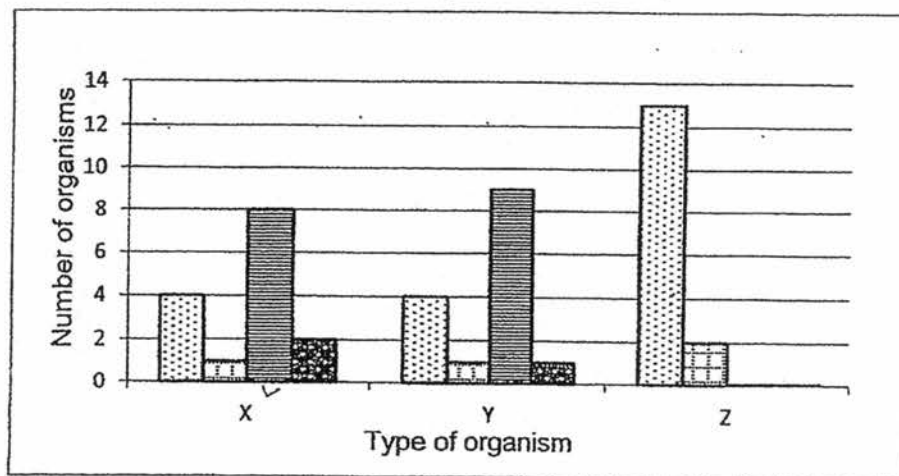

Which of the following statements are true?

- A: Only organism Y can be found in the leaf litter habitat.
- B: Organism Z prefers an environment that is bright and wet.
- C: Both organisms X and Y survive best in an environment that is damp and dark.

- (1) A and B only
- (2) A and C only
- (3) B and C only
- (4) A, B and C

12. Study the two graphs below. They show the amount of carbon dioxide present in the air in two towns, X and Y, over a period of time.

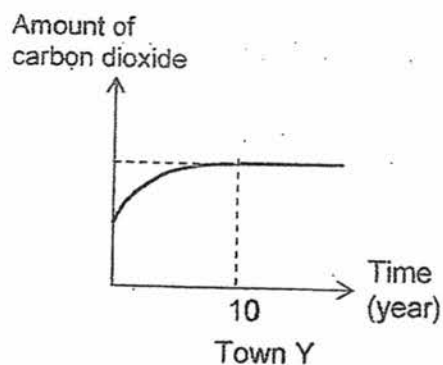
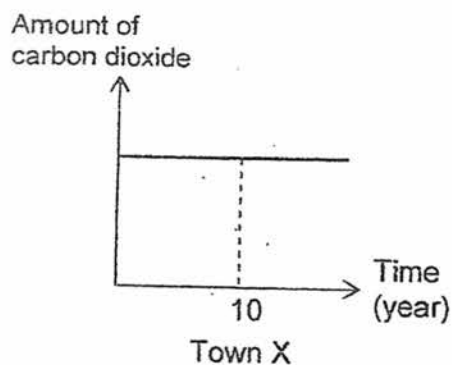

From the graphs, we can infer that

- A: The air in town Y is less polluted than town X after year 10.
- B: There could be a decrease in the number of factories in town Y in the first 10 years.
- C: There could be deforestation in town Y in the first 10 years.
- D: The number of cars in town Y could have increased in the first 10 years.

- (1) A and B only
- (2) C and D only
- (3) A, B and C only
- (4) B, C and D only

13. May wanted to find out how the different time of the day affects the amount of carbon dioxide produced by a plant. She placed a potted plant in a sealed transparent container and placed it in an open field from morning till night. Which of the following graphs most likely shows the result of her experiment?

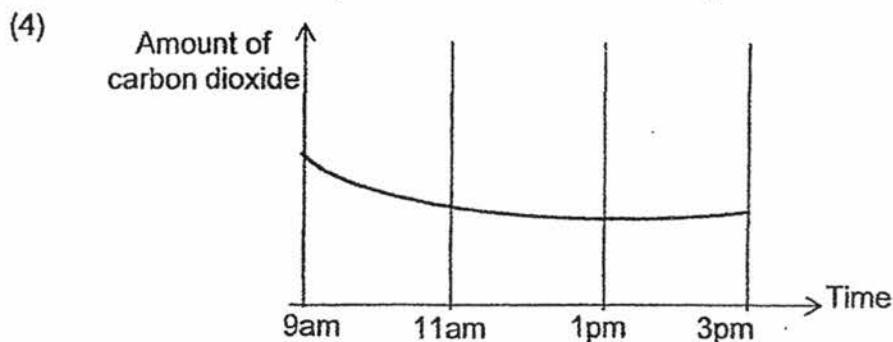
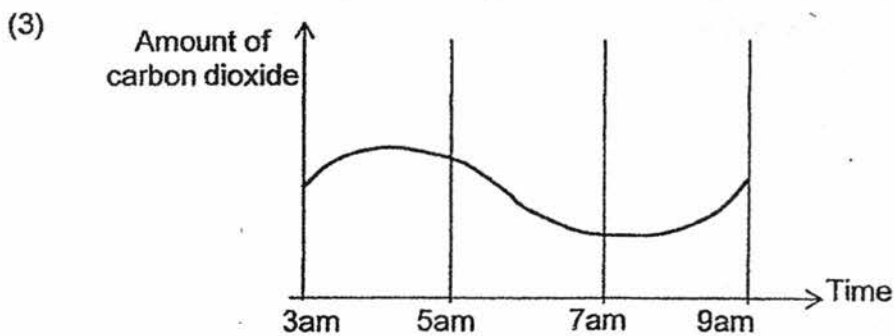
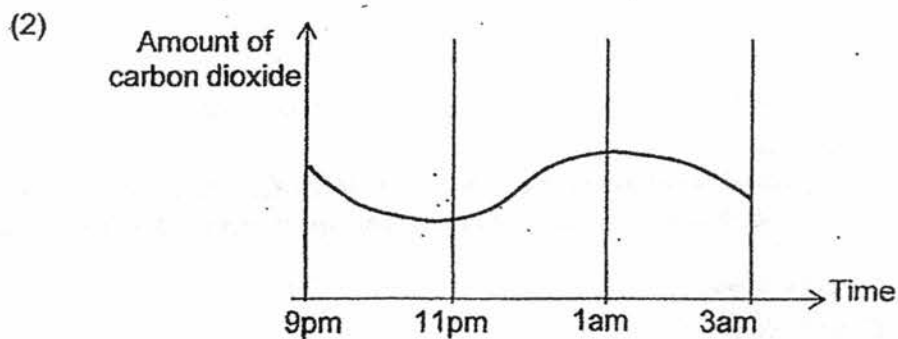
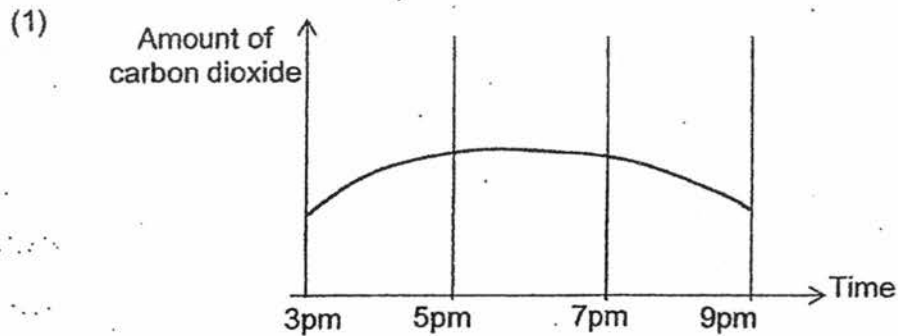

14. Alice removed an outer ring of a stem from a potted plant as shown below. As a result, the tubes carrying food and water were removed. She covered leaf X partially with black paper on both sides. She watered the plant regularly and placed it under the sun.

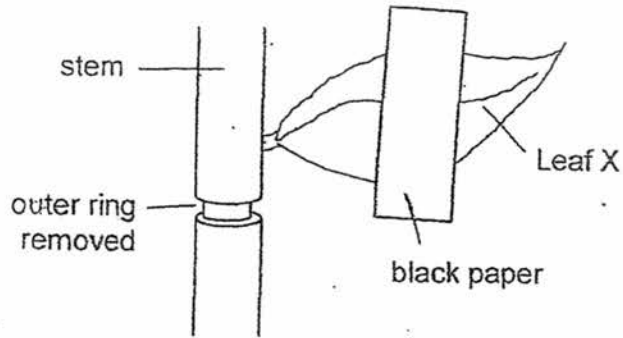

After a week, Alice removed leaf X and tested for starch.

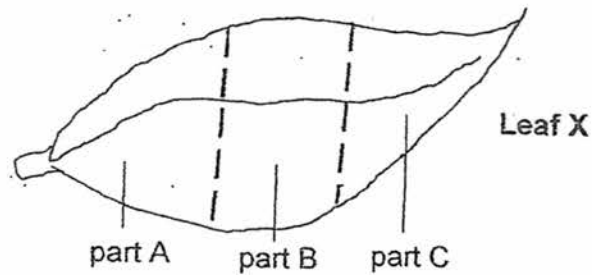

Which part(s) of the leaf would the iodine solution remains yellowish brown?

- (1) A only
- (2) B only
- (3) A and C only
- (4) A, B and C

15. Siew Lee has four different materials, A, B, C and D, that have been cut to the same size and shape. They have a mass of 2g each at the start of the experiment.

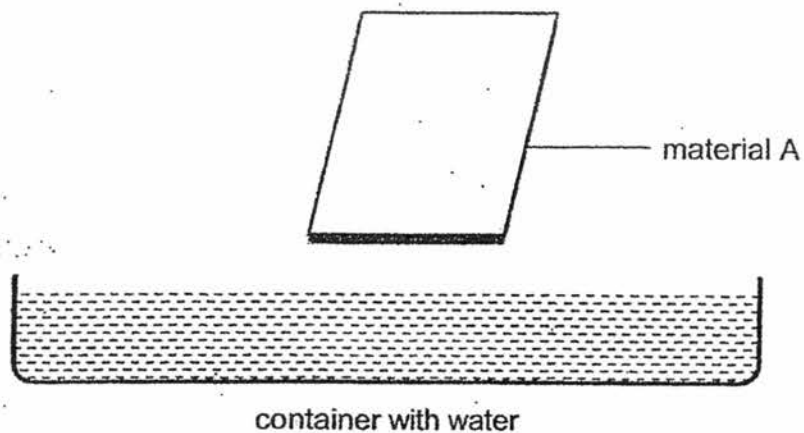

She dipped material A in the container of water for 10 minutes and measured its mass after that. She repeated the experiment with materials B, C and D and recorded her observations in the table shown below.

Material	Mass at the start (g)	Mass in the end (g)
A	2	4
B	2	2.5
C	2	3
D	2	2

Based on the above results, which material will be the most suitable for Siew Lee to make a hand towel?

- (1) A
- (2) B
- (3) C
- (4) D

16. Mr Tan tried to pull two different boxes over the same distance as shown below.

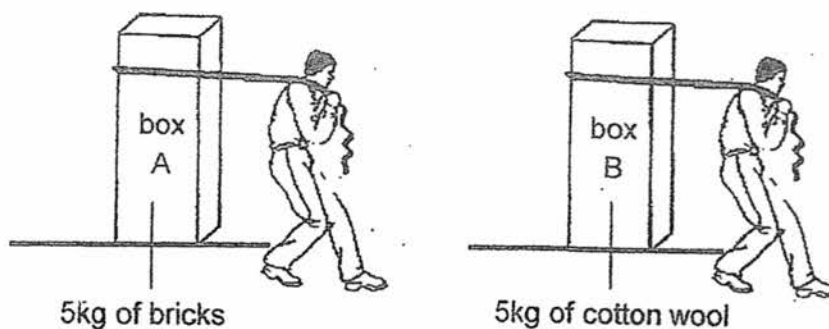

box	force applied by Mr Tan
A	50 units
B	35 units

Which of the following correctly explains why Mr Tan had to use more force to pull box A?

- (1) Box A has more volume than box B.
 - (2) Bricks are heavier than cotton wool.
 - (3) The base of box A is rougher than box B.
 - (4) The cotton wool has air spaces while the bricks do not.
17. The table below shows the freezing point and boiling point of three substances.

substance	freezing point (°C)	boiling point (°C)
W	40	200
X	10	137
Y	98	987

Which of the following shows the correct state of the substances at 440 °C?

	substance W	substance X	substance Y
(1)	gas	liquid	solid
(2)	gas	gas	liquid
(3)	solid	liquid	gas
(4)	liquid	solid	gas

18. Three containers were filled with the same amount of water and placed on a table in the same room.

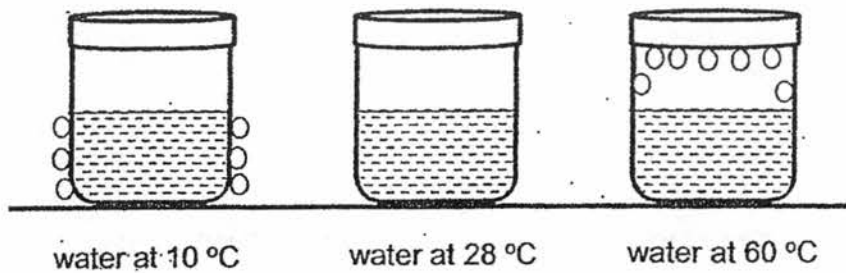

At the end of ten minutes, water droplets could be seen on the containers as shown above.

What is the possible temperature of the room?

- (1) 90°C
- (2) 29°C
- (3) 15°C
- (4) 11°C

19. Three students made the following statements.

Danny : Only metals are conductor of electricity.
Elaine : We should handle electrical appliances only with dry hands.
Frank : A closed electrical circuit must comprise a bulb, wires and a switch.

Which of the students is/are correct?

- (1) Elaine only
- (2) Frank only
- (3) Danny and Elaine only
- (4) Danny and Frank only

20. James made a circuit card as shown in figure 1. He connected an electrical circuit as shown in figure 2 to figure 1.

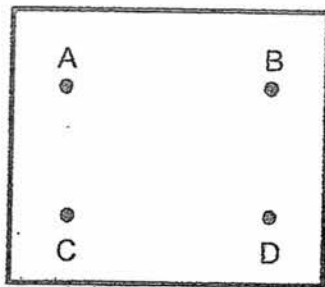

figure 1

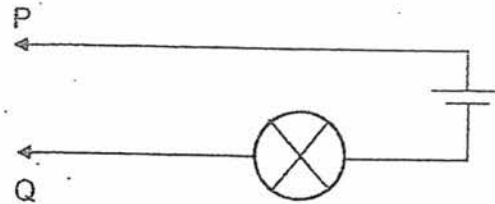
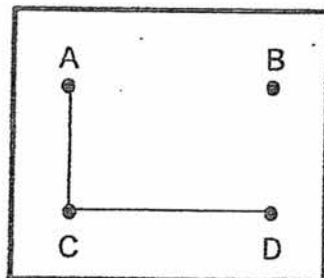

figure 2

pin connected to P	pin connected to Q	Did the bulb light up?
A	C	Yes
B	D	No
A	D	Yes
B	C	No

Which of the diagrams below is/are possible connection(s) in the circuit card?

A)



B)

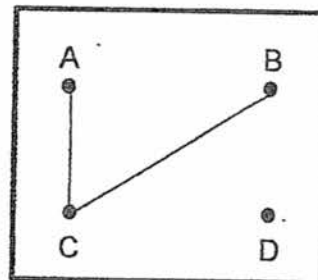

C)

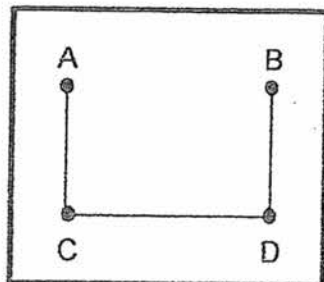

D)

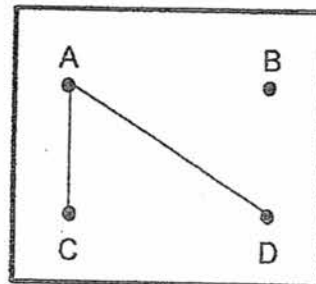

- (1) A only
 (2) B only
 (3) A and C only
 (4) A and D only

21. Jack created a circuit as shown below.

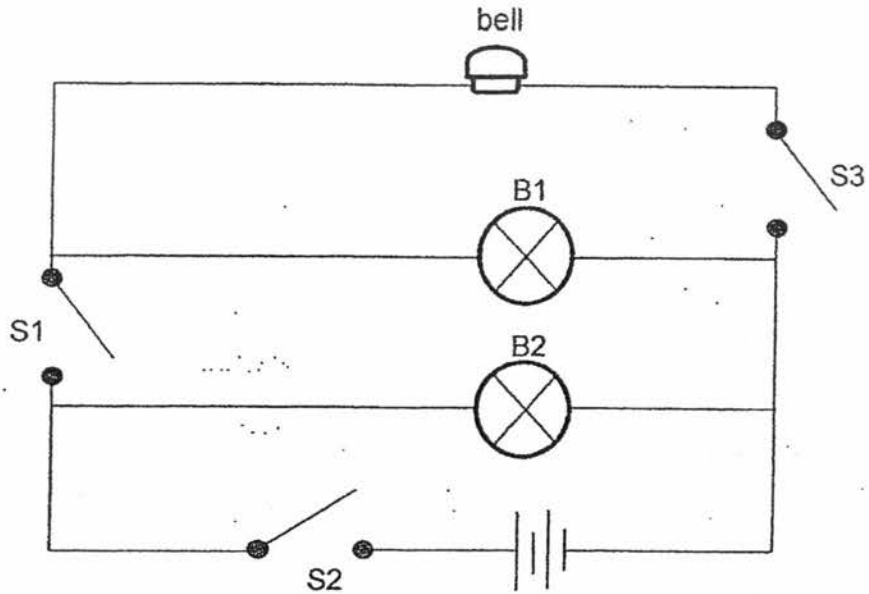

Which of the following is correct when Jack controlled the switches?

	S1	S2	S3	Observation
(1)	open	closed	closed	Only the bell will ring.
(2)	open	open	closed	Only bulb B1 lit up and the bell rang.
(3)	closed	closed	open	Only bulbs B1 and B2 lit up.
(4)	closed	open	open	Only bulb B1 lit up.

22. The diagram below shows a conveyor belt which separates two different types of beads, A and B.

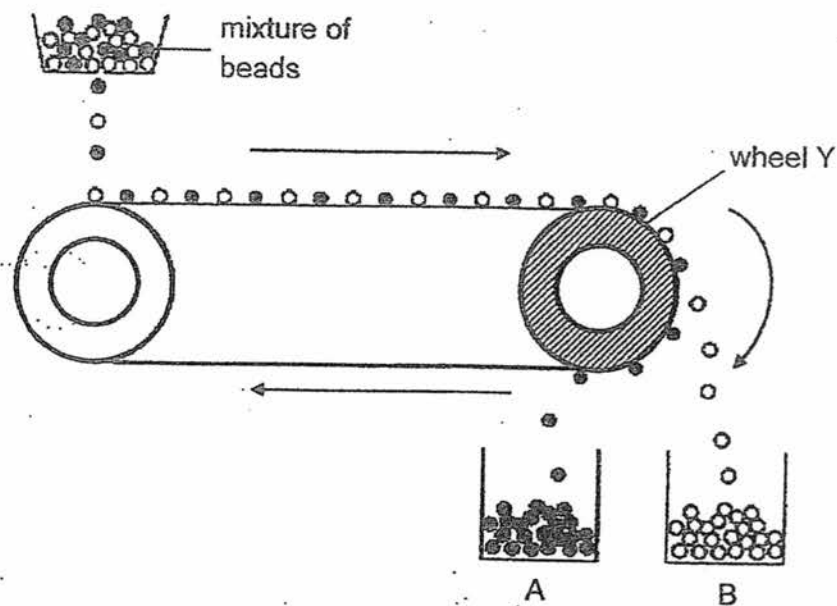

For the separation to be done, which of the following is correct?

	wheel Y	material used to make beads A	material used to make beads B
(1)	magnet	steel	copper
(2)	magnet	aluminium	steel
(3)	plastic	copper	aluminium
(4)	plastic	aluminium	steel

23. Rashid hung four balls, A, B, C and D, which are made of different materials. All four balls were released from the holder at the same time and the depressions made in a basin of soft dough were measured.

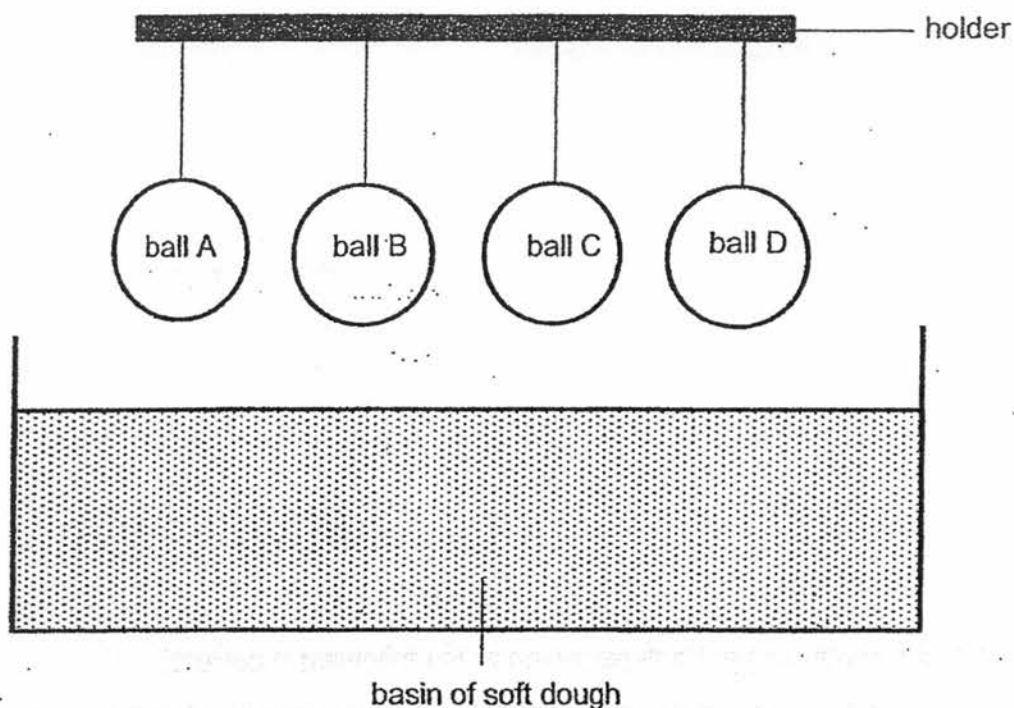

He recorded the depressions made in the soft dough as shown in the table below.

ball	A	B	C	D
depression	2cm	4.5cm	1cm	0.5cm

Which of the following shows the correct arrangement of the balls from the lightest to the heaviest?

- (1) D, C, A, B
- (2) B, A, C, D
- (3) C, A, B, D
- (4) A, B, D, C

24. Ali conducted an experiment to find out how the size of the sail affects the distance moved by the sailboat. The table below shows the size of the sails used. The same amount of wind was present for all the experiments.

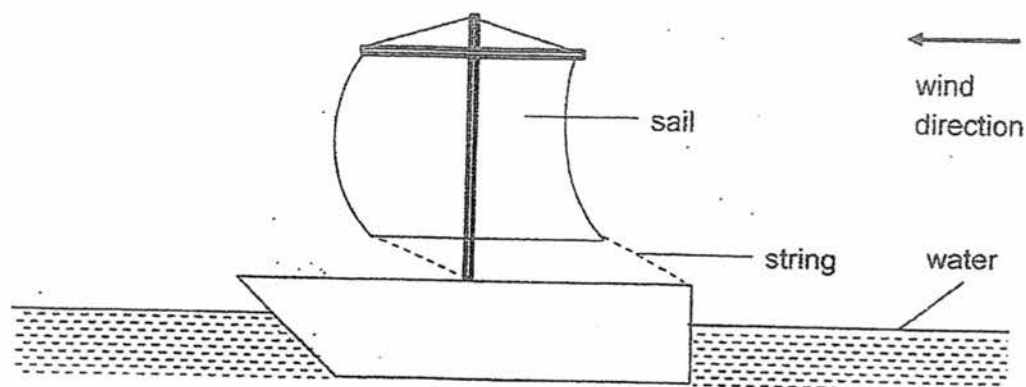

sailboat	size of the sail (cm ²)
A	65
B	55
C	100
D	80

Which graph shows the correct distance moved by the sailboat?

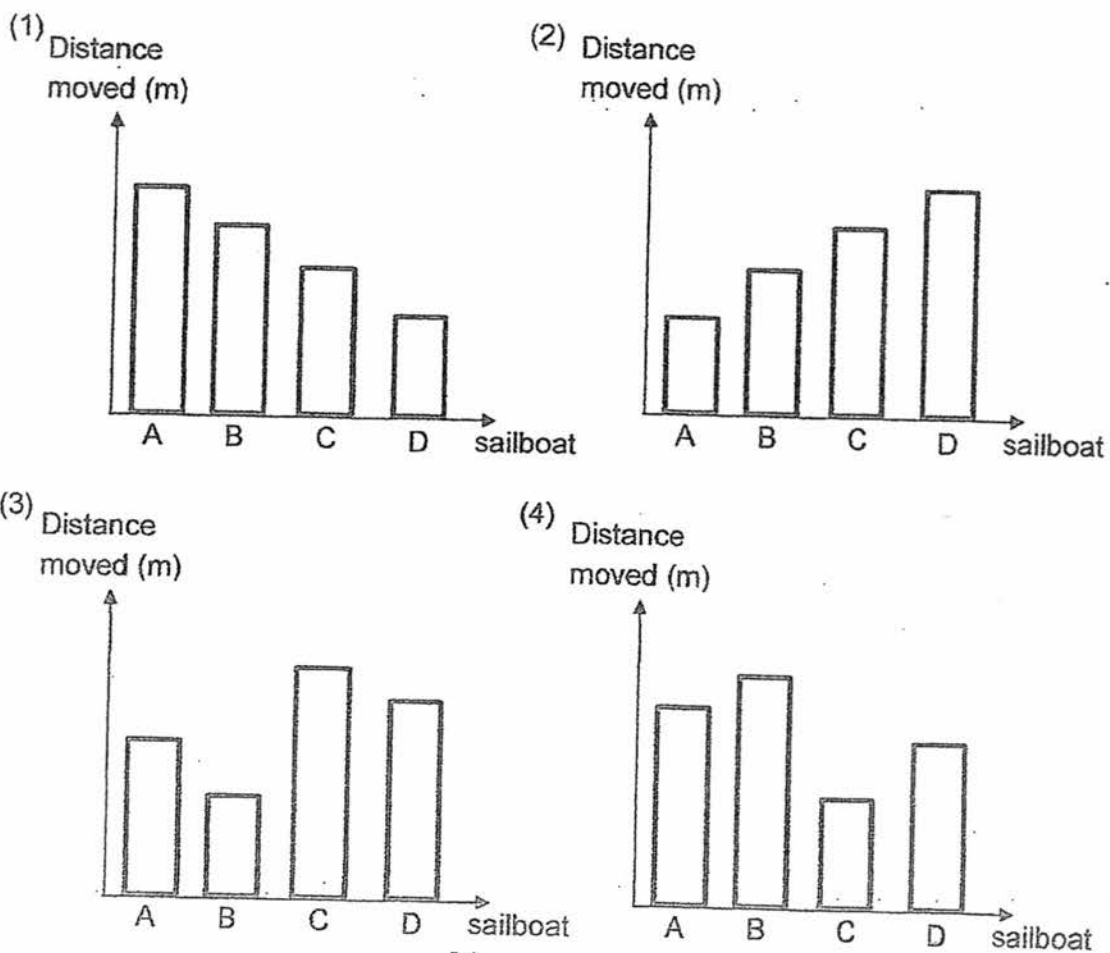

25. Caleb created the set-up shown below. The buzzer will sound each time he closes the switch.

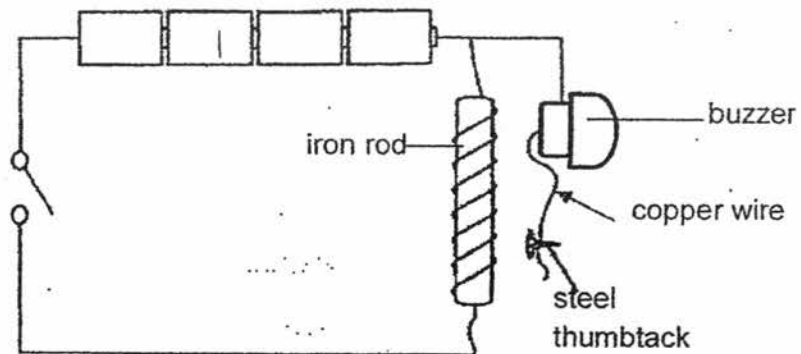

After changing the set-up, Caleb noticed that the buzzer did not sound when the switch was closed. What change(s) did he make?

- A : Add one more battery without changing the rest of the set-up.
- B : Coil more turns of wire around the iron rod without changing the rest of the set-up.
- C : Change the steel thumbtack to a copper thumbtack.

- (1) C only
- (2) A and B only
- (3) B and C only
- (4) A, B and C

26. Ravi plays basketball during his free time and he observed the height the ball bounces back each time after it hits the ground.

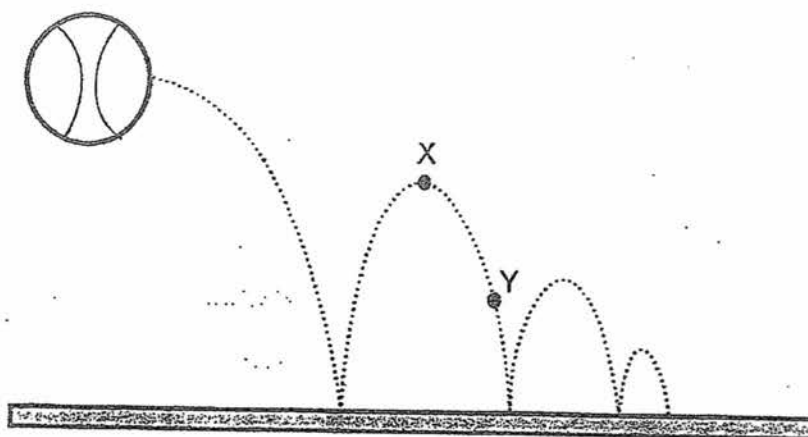

Study the following statements.

- A: There is more gravitational force acting on the ball at position X than at position Y.
- B: The amount of gravitational potential energy on the ball is the same at both positions X and Y.
- C: From position X to Y, the gravitational potential energy of the ball decreases but the kinetic energy increases.
- D: From position X to Y, the gravitational potential energy of the ball increases but kinetic energy decreases.

Which of the above statements is/are true?

- (1) A only
- (2) C only
- (3) B and D only
- (4) A, B and C only

27. Study the hydroelectric power station shown below.

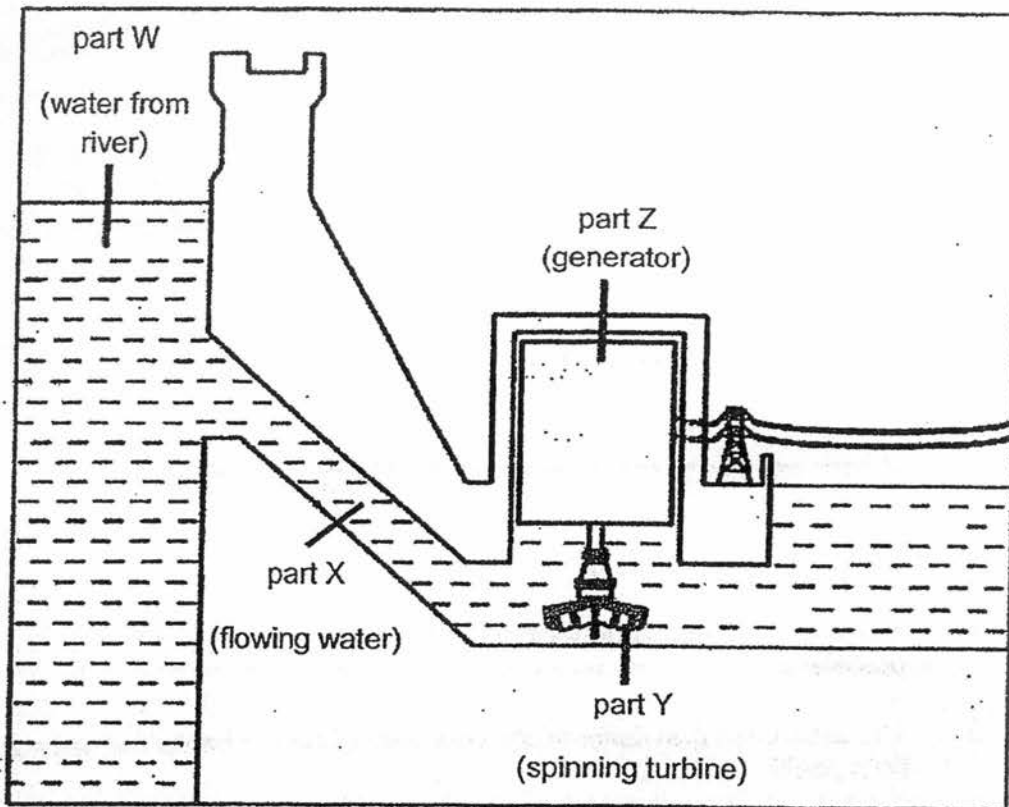

Which of the following shows the correct main energy conversion from parts W to part Z?

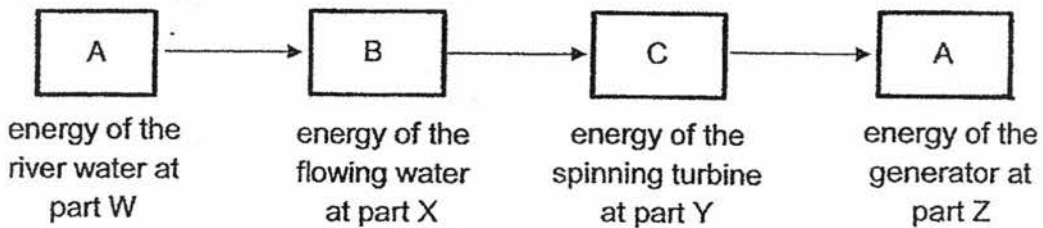

	A	B	C	D
(1)	kinetic energy	gravitational potential energy	sound energy	electrical energy
(2)	gravitational potential energy	kinetic energy	kinetic energy	electrical energy
(3)	electrical energy	gravitational potential energy	kinetic energy	kinetic energy
(4)	gravitational potential energy	electrical energy	heat energy	kinetic energy

28. Cheryl placed five similar ice cubes into three different bags as shown below. The bags were made of the same material but with different thickness.



bag A



bag B



bag C

All the bags were placed at the same location. A few of her classmates made the following statements:

Paul : Crush all the ice so that they can melt faster.

Queny : For all the ice in bag B and bag C to complete melting at the same time, bag C will need more heat than bag B.

Rose : Since they are placed at the same location, the ice in all three bags will melt completely at the same time.

Which of the student(s) is/are correct?

- (1) Paul only
- (2) Rose only
- (3) Paul and Queny only
- (4) Queny and Rose only

END OF SECTION A



RED SWASTIKA SCHOOL

SCIENCE 2017 PRELIMINARY EXAMINATION PRIMARY 6

Name : _____ ()

Class : Primary 6/ _____

Date : 25 August 2017

BOOKLET B

13 Questions
44 Marks

In this booklet, you should have the following:

- Page 26 to Page 41
- Questions 29 to 41

MARKS

	OBTAINED	POSSIBLE
BOOKLET A		56
BOOKLET B		44
TOTAL		100

Parent's Signature : _____

SECTION B

Answer all the questions in the spaces provided.

29. Study the classification chart below.

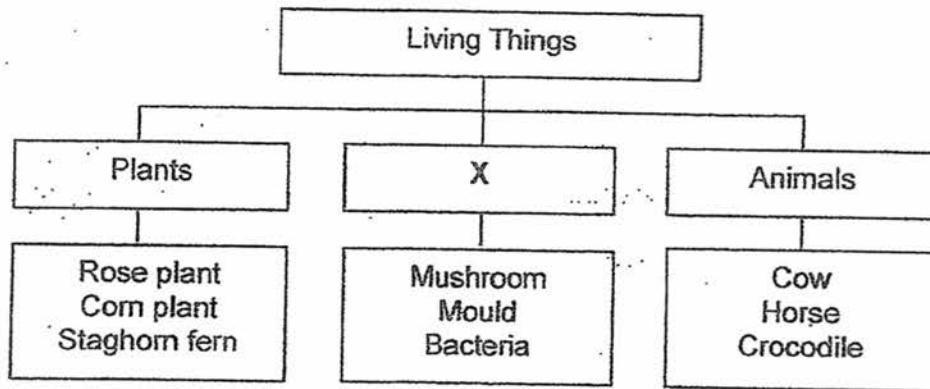

(a) Write a suitable heading for group X. (1m)

(b) The animals produce waste in the form of droppings. State the process that breaks down the droppings into simpler substances that is useful for plants to grow better. (1m)

(c) Based on your answer in (b), state how the simpler substances help the plants to grow better. (1m)

(d) If group X contains only mushroom and mould, what is a suitable heading for this new group? (1m)

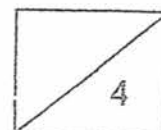

30. 'Simply Fresh' is a soluble substance that helps to keep flowers fresh for a longer time. Mrs Tan wanted to investigate if this is true. She used two similar vases, X and Y, for her experiment.

The items in vase X are shown in the table below. She also created a control set-up using vase Y.

Vase	Number of roses	Amount of 'Simply Fresh'	Amount of tap water	Temperature of tap water
X	6	5 ml	1500 ml	30°C
Y				

- (a) Complete the above table to show how Mrs Tan should set up vase Y. (1m)
- (b) State one other important variable Mrs Tan must keep the same during the experiment to ensure a fair test. (1m)

- (c) Explain why Mrs Tan has set up a control for her experiment. (1m)

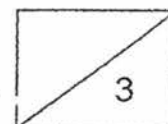

31. Muthu learned in school that there are more stomata found on the lower surface of leaves. He then set up an experiment using four similar potted plants, A, B, C and D, as shown below. He applied oil on different parts of their leaves. All four plants were placed side-by-side under light and watered with equal amounts of water daily.

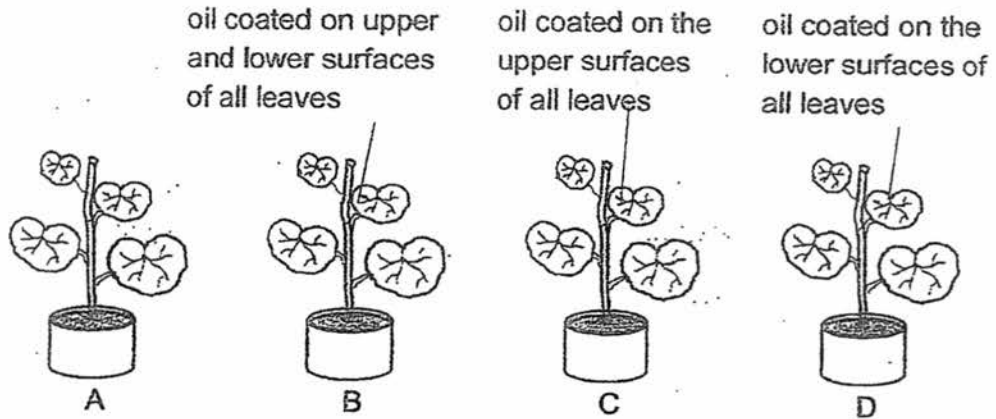

- (a) Arrange the order in which the plants above would die, starting with the plant that takes the shortest time to the one that takes the longest time. (1m)

--	--	--	--

- (b) Muthu took another plant and tied a clear plastic bag around it as shown below. He did not apply any oil to the leaves. The plant was provided with sufficient light and water.

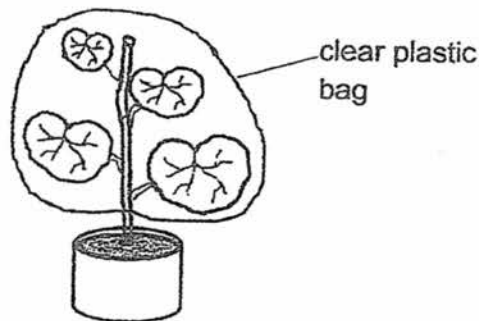

He observed substance Z forming on the inner surface of the plastic bag after a few days.

- (i) What was substance Z? (1m)

- (ii) Explain how substance Z was formed. (2m)

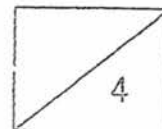

32. Study the food web shown.

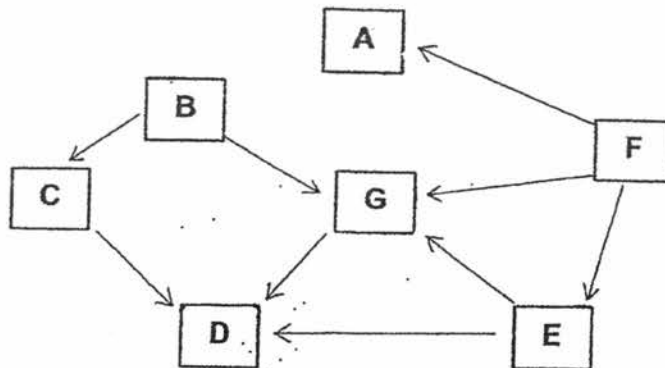

(a) Based on the food web, fill in the table below with the appropriate letters, B, C, D, E, F and G. Do not use letter A. (2m)

	Type of organism	Letter (s)
(i)	Food producer	
(ii)	Prey only	
(iii)	Predator only	
(iv)	Both a prey and predator	

(b) Using the following information, draw two arrows to add organism H in the food web above. (1m)

- (i) Organism H is a plant and animal eater.
- (ii) When the population of organism H increases, the population of organism B decreases.
- (iii) When the population of organism H decreases, the population of organism A increases.

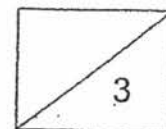

33. The table below shows how some animals adapt to survive in their habitats.

Animal	Adaptation	How the adaptation enables the animal to survive in its habitat
A	hibernates	to avoid food shortages in winter
B	has a long neck	to eat leaves from tall trees
C	flies south during winter	to find warmth
D	has sharp claws	to catch its prey

- (a) Based on the information above, classify the animals given using the flow chart below. Write letters, A, B, C and D in the correct boxes, using each letter once. (2m)

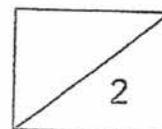
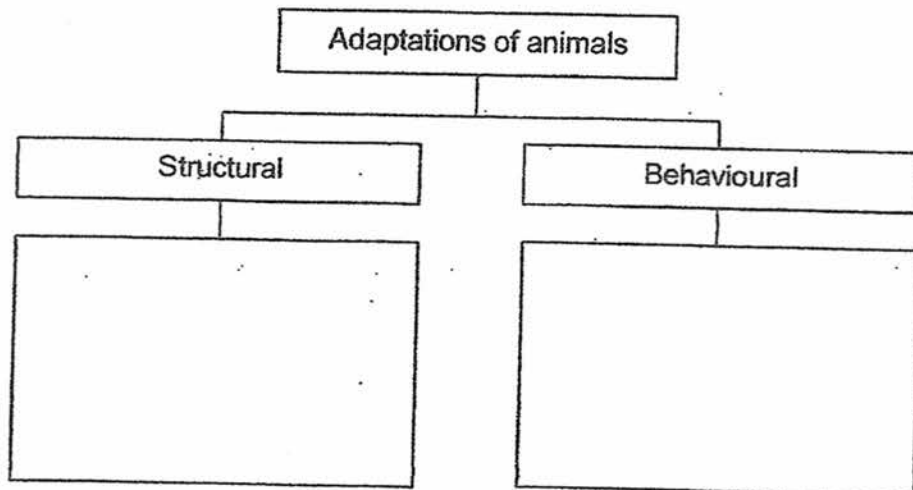

33. Man causes most pollution. Deforestation can cause not only air pollution but also water pollution. When trees in the forest are cut down, the soil is blown into the air or washed into the river easily.

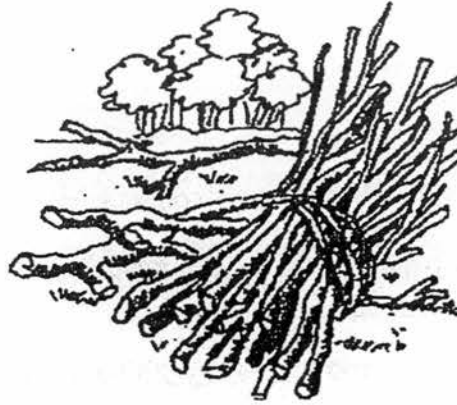

- (b) (i) Explain how trees in a forest help to prevent soil from being washed away. (1m)

- (ii) When a lot of loose soil is washed into a river, the water becomes dark and murky. The underwater plants do not grow well. Explain why. (2m)

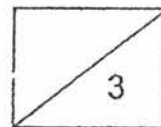

34. Natasha wanted to find out if the rate of photosynthesis of elodea would be affected by the intensity of light. She put the same type of plant into three glass containers and placed each of them at different distances from three similar table lamps in a dark room for an hour.

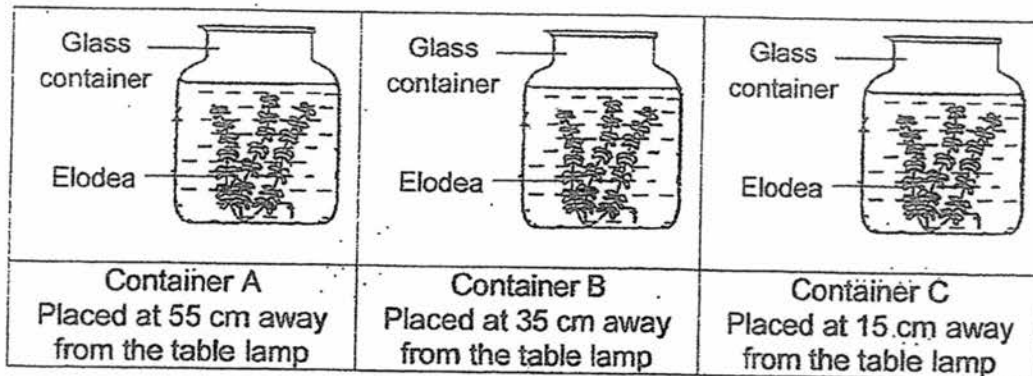

She recorded the number of bubbles produced at 5 minutes interval for one hour and plotted the graph below to show the results in container B.

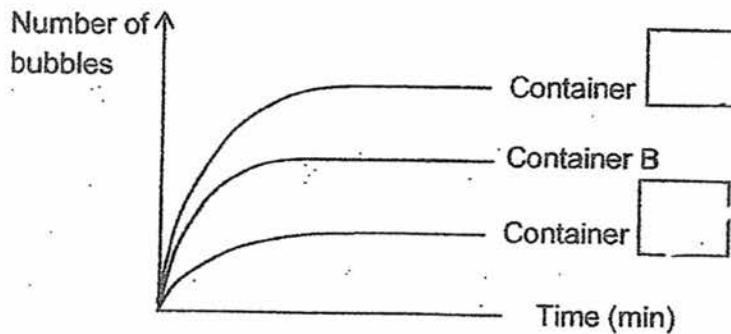

- (a) Using the same graph above, label the graph to show the results of the experiment in containers A and C respectively. (1m)
- (b) Natasha added a few guppies into container B. She placed the container at 35 cm away from the table lamp as she had done previously and repeated the experiment again.

She observed that the number of bubbles produced by the elodea was more. Explain her observation. (2m)

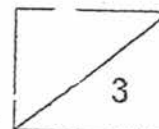

35. Mr Tan drew his family tree as shown below.

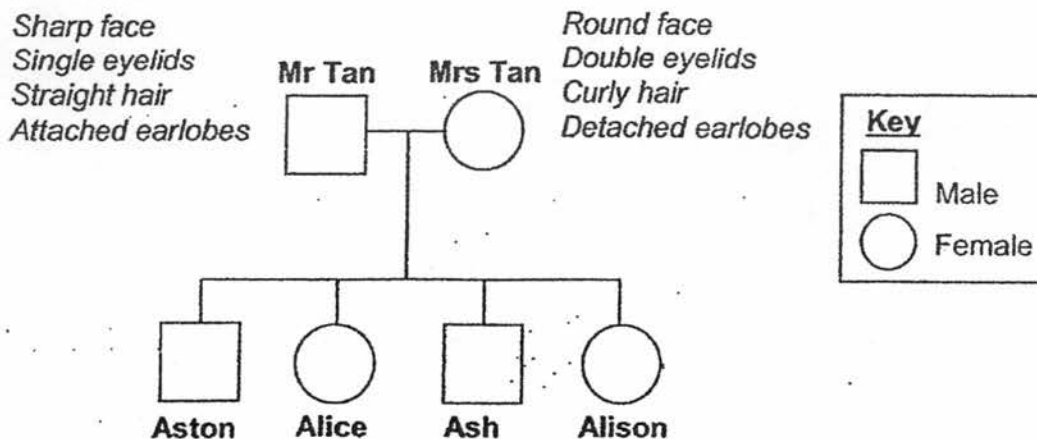

The table below shows the characteristics of his children.

	Face	Eyelids	Hair	Earlobes
Aston	Round	Double	Curly	Detached
Alice	Sharp	Single	Straight	Detached
Ash	Sharp	Single	Curly	Attached
Alison	Sharp	Double	Straight	Detached

(a) Based on the information above, what are the common characteristics Alice and Alison have inherited from their father? (1m)

(b) Alison is married and she has a young son. Draw lines and symbols to represent her husband and son in the family tree. (1m)

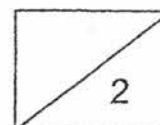

36. Study the set-up shown below.

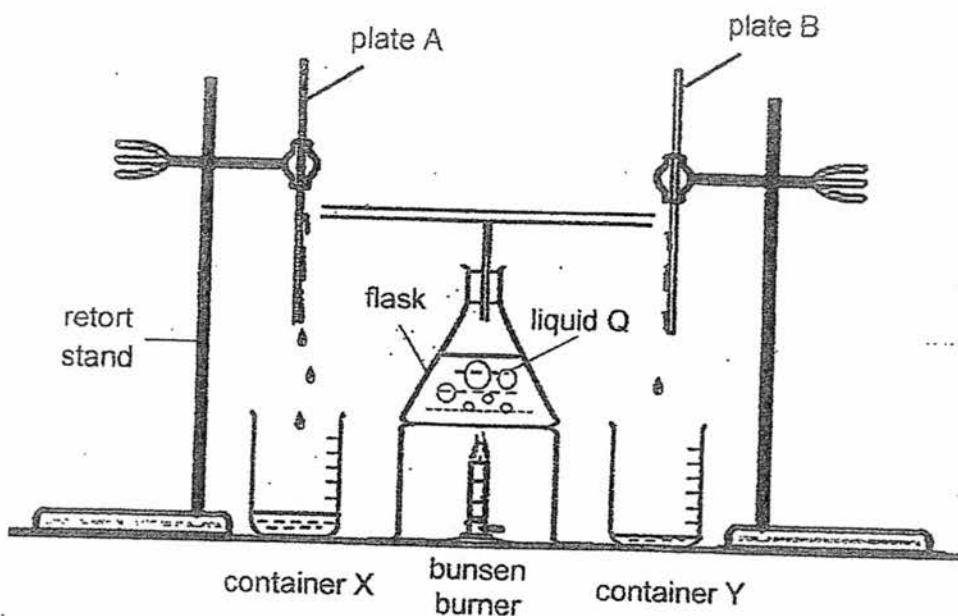

After the bunsen burner was lit up, some liquid was seen to be collected in both containers X and Y.

- (a) Plates A and B are made of different materials. Explain the difference in the amount of liquid collected for container X. (1m)

- (b) Liquid Q is blue in colour as blue dye powder was added to it. However, the liquid collected in container X was colourless. Explain why. (1m)

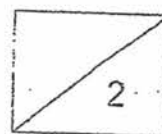

37. Andy has a solid that is made up of substances A and B as shown below.

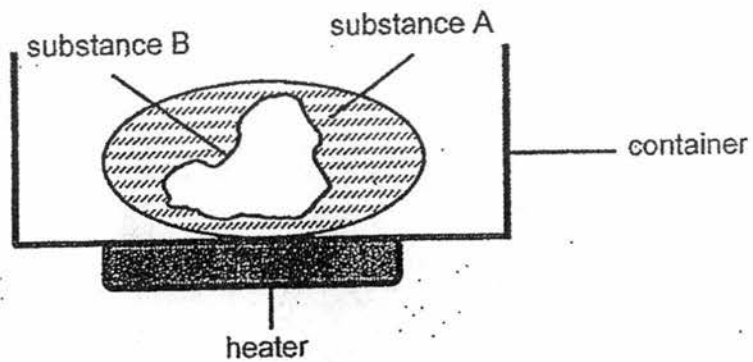

Substance A has a much lower melting point than substance B. Andy would like to make object X using only substance A as shown below.

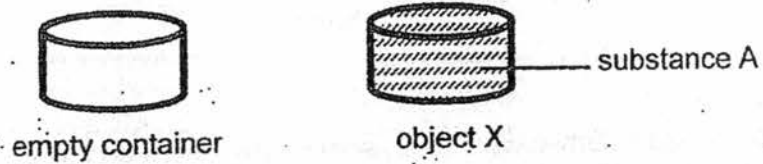

Explain how he could create object X using the empty container and the set-up shown above. (2m)

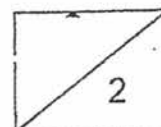

38. Raja created the following set-up. He wanted to find out how the different table surfaces affects the distance moved by the box on the table.

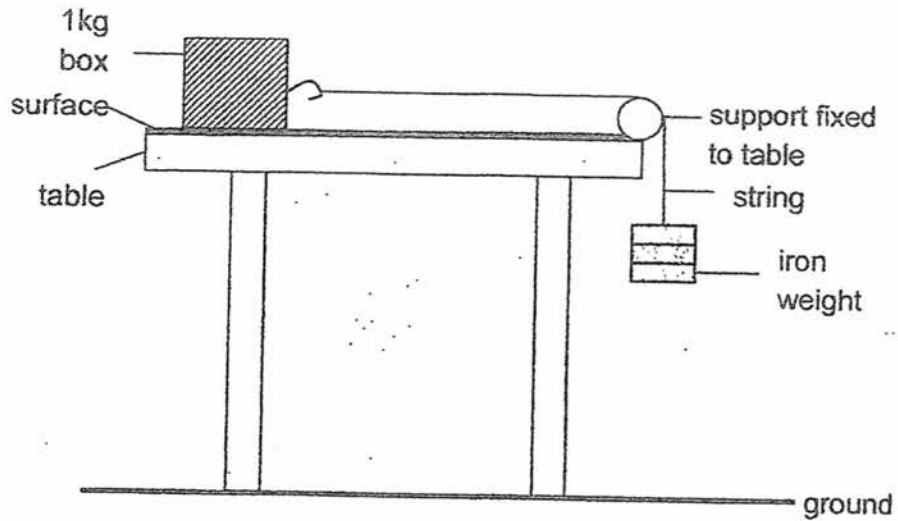

He repeated the experiment with two other surfaces and the same amount of iron weights. He recorded the distance moved by the box on the table as follows.

surface	distance moved by the box (cm)
P	9
Q	3
R	7

- (a) Tick(✓) the correct columns in the table below in order for the experiment to be a fair test. (1m)

variable	change	keep the same
material of the 1kg box		
material of the surface		
mass of iron weights		
length of string		

- (b) Which surface, P, Q or R, is best used to make the soles of shoes? Explain your answer. (1m)

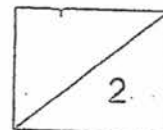

39. Study the set-up shown below.

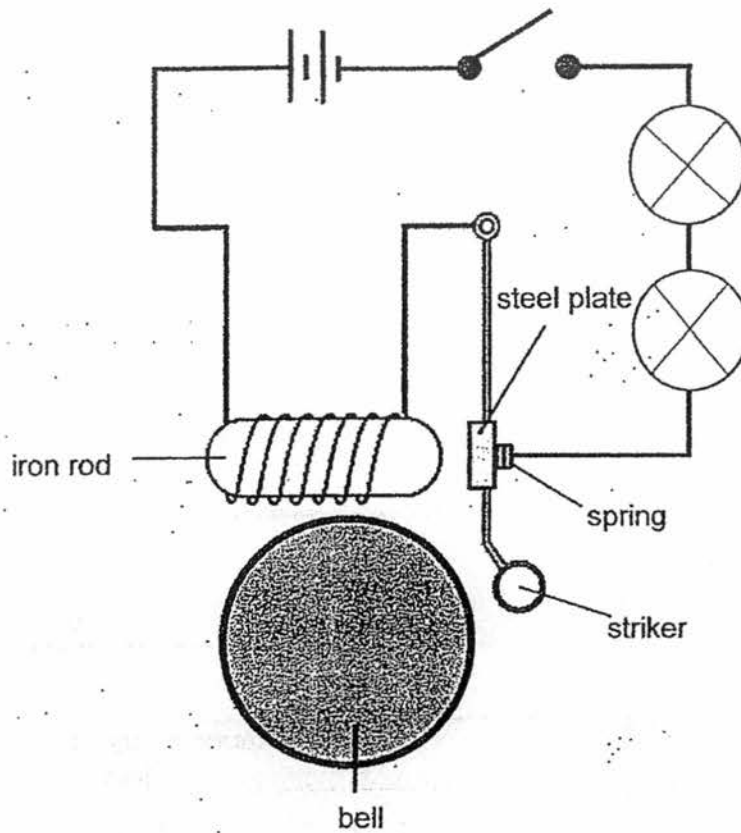

In the set-up, a steel plate is attached to a spring.

(a) What type of arrangement are the bulbs arranged in? (1m)

(b) Describe how the iron rod helps the bell to ring. (2m)

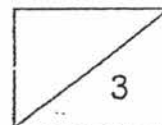

39. After the steel plate was replaced with object X, the bulbs lit up but object X did not move at all.

(c) Based on the above results, state two properties of the material for object X. (2m)

Property 1: _____

Property 2: _____

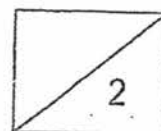

40. Alan went for a holiday and took a ride in a hot air balloon as shown below.

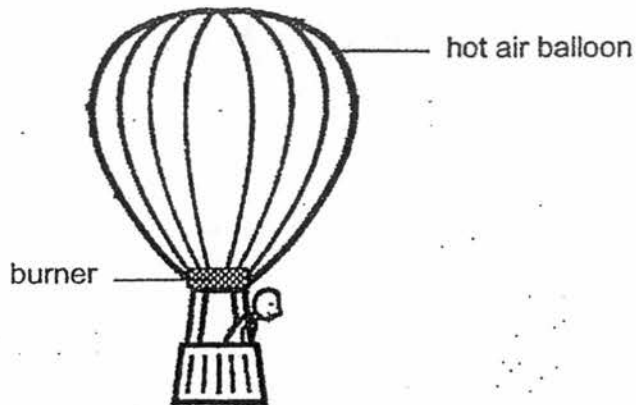

When the burner was switched on, it heated up the air inside the balloon. The hot air fills the balloon, causing it to rise.

- (a) If the hot air balloon is already in the air, what could Alan do if he would like the balloon to go higher up in the air? (1m)

Study the electrical system shown below. When the switch is closed, the nichrome wire, which is connected to the wires in the circuit, becomes hot and soon, the piece of paper moved.

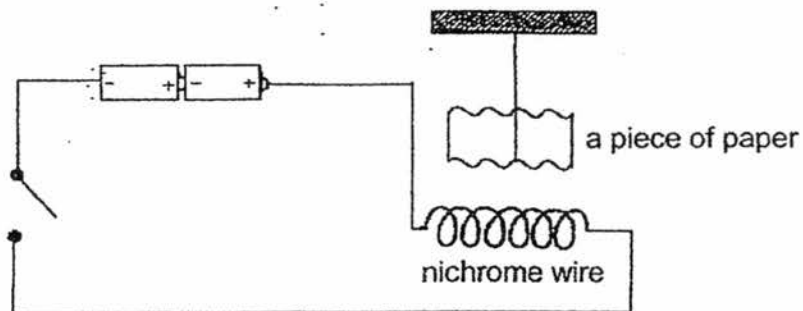

- (b) Fill out the boxes below to show the energy conversion in the circuit. (1m)

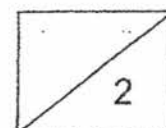
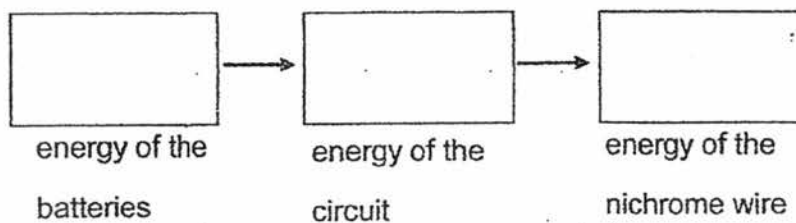

40(c) Explain why the piece of paper moved when the switch was closed. (2m)

(d) Another similar experiment was created but only one battery was used. Will the speed of the moving paper be different? Explain. (1m)

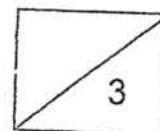

41. Sally is going for a picnic. She packed the same type and amount of food in two different containers which are of the same size. The containers are made of different materials and the covers remained closed once the food was put in.

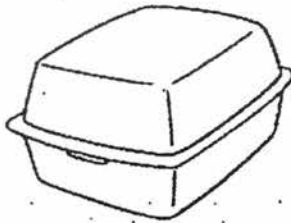

container A

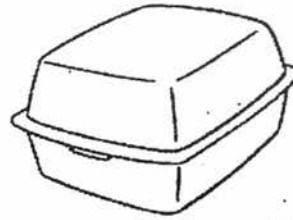

container B

After one hour, Sally checked on the food and observed the results as shown in the table below.

	container A	container B
Is the food still warm?	Yes	No

- (a) Based on the above information, state a possible reason why the food in container A is still warm but not container B. (1m)

- (b) Fishmongers keep fish fresh by storing them in containers filled with ice. Based on the data from the table only, which container, A or B, is made of a material which is less suitable for making the container to keep fish fresh? Explain your answer. (2m)

- (c) Sally observed that the surface of container A became wet. However, the surface of container B remained dry. What can be concluded about the material used to make container A? (1m)

END OF SECTION B
PLEASE CHECK YOUR WORK

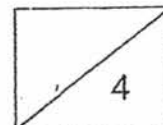

YEAR : 2017
LEVEL : PRIMARY 6
SCHOOL : RED SWASTIKA
SUBJECT : SCIENCE
TERM : PRELIMINARY EXAMINATION

Booklet A

Q1	Q2	Q3	Q4	Q5	Q6	Q7
4	2	1	2	2	4	1
Q8	Q9	Q10	Q11	Q12	Q13	Q14
4	1	3	3	2	4	4
Q15	Q16	Q17	Q18	Q19	Q20	Q21
1	3	2	2	1	4	3
Q22	Q23	Q24	Q25	Q26	Q27	Q28
1	1	3	1	2	2	3

Booklet B

Q29 (a) Decomposer

Q29 (b) Decomposition

Q29 (c) The simpler substances broken down by the decomposers acts as fertilisers.

Q29 (d) Fungi

Q30 (a)

Y	6	0 ml	1500 ml	30°C
---	---	------	---------	------

Q30 (b) Mrs Tan must put both vases X and Y in the same location.

Q30 (c) A control set-up allows her to compare and confirm that any difference in the duration the flowers remain fresh is due to the use of 'simply fresh' which is the only variable.

Q31 (a)

B	D	C	A
---	---	---	---

Q31 (b) (i) Water droplets

(ii) Water vapour is given out by the plants through the opening. When the water vapour comes into contact with the cooler inner surface of the plastic bag, it loses heat and condenses to form water droplets on the plastic bag.

Q32 (a)

	Type of organism	Letter (s)
(i)	Food producer	F
(ii)	Prey only	C and E
(iii)	Predator only	D
(iv)	Both a prey and predator	G

Q32 (b)

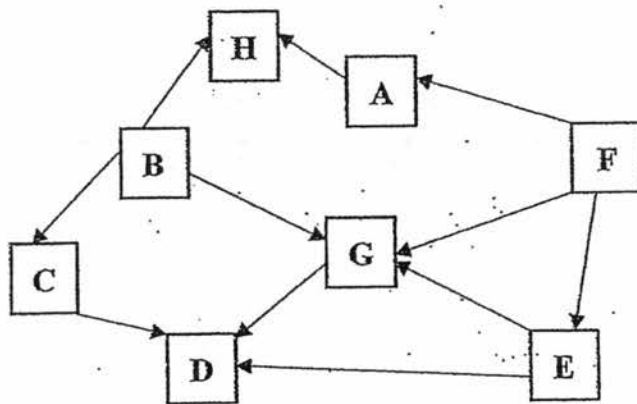

Q33 (a)

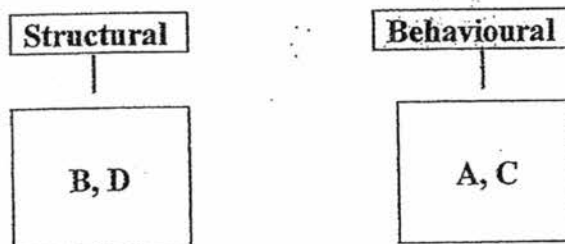

Q33 (b) (i) The tree roots help to grasp the soil in position.

(ii) The soil reduces the amount of sunlight entering the water. As a result, the plants photosynthesize less and produced less oxygen.

Red swastika prelin.

Q34 (a) Container C

Container A

Q34 (b) Carbon dioxide is needed for photosynthesis. Guppies breath out carbon dioxide therefore when there is more carbon dioxide, the plant would photosynthesise more. Producing more bubbles which have oxygen in it.

Q35 (a) Sharp face & straight hair.

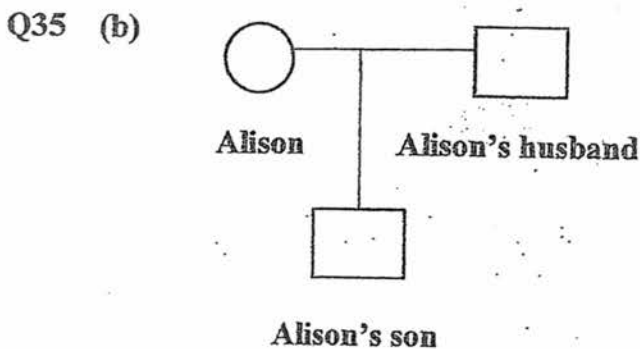

Q36 (a) More water was collected in container X as the amount of water vapours that lost heat and condensed on plate A is more. This shows that plate A is a better conductor of heat than plate B.

Q36 (b) Only liquid can evaporate, solid like the blue dye powder can't therefore when liquid Q gained heat from the bunsen burner and evaporated it was colourless as the powder could not evaporate with the liquid.

Q37 Andy could on the heater's temperature below substance B's melting point so when substance B melts finish, Andy could pour it away. Andy could then put the empty container on standby so when substance A finish melting, it could pour it into the empty container.

Q38 (a)

variable	change	keep the same
material of the 1kg box		✓
material of the surface	✓	
mass of iron weights		✓
length of string		✓

Q38 (b) Surface Q. The distance moved by the box is the least. There is the most friction between the box and the surface and can prevent the user from slipping.

Q39 (a) Series

Q39 (b) When the circuit is closed, the iron rod became magnetised and attracts the steel plate which is a magnetic material. This results in the striker hitting the bell.

Q39 (c) Property 1: Object X is a non-magnetic material.

Property 2: Object X is a conductor of electricity.

Q40 (a) Alan could make the fire burn bigger.

Q40 (b)

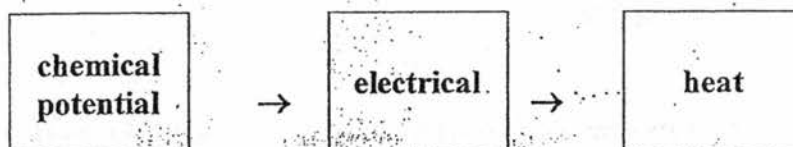

Q40 (c) When the nichrome wire is heated, the air surrounding the wire is heated. Air expands when heated and pushes the paper as the air takes up more space.

Q40 (d) Yes. There will be less electrical energy to heat the nichrome wire. The surrounding air will expand less, reducing the speed of the paper.

Q41 (a) Container A is made out of a poor conductor of heat and container B is made out of a good conductor of heat.

Q41 (b) Container B. It allows more heat to flow from the surrounding air to the container. The ice gains heat and melts more quickly. This will not keep the fish fresh.

Q41 (c) The material is not waterproof.

End

4