



ZHONGHUA SECONDARY SCHOOL Preliminary Examination 2017

CANDIDATE NAME			()
CLASS			

SCIENCE (PHYSICS/CHEMISTRY)

5076/01

Paper 1 Multiple Choice

15 September, 2017

Secondary 4 Express/ 5 Normal (Academic)

1 hr

Set by: Mr Lawrence Tang

Mrs Maybrie Ang

Vetted by: Mr Tan Jun Hong

Ms Ong Lay Hong

READ THESE INSTRUCTIONS FIRST

Write in soft pencil.

Do not use staples, paper clips, highlighters, glue or correction fluid.

Write your name, index number and class on the OTAS Answer Sheet in the spaces provided.

There are **forty** questions on this paper. Answer all questions. For each question there are four possible answers **A, B, C** and **D**.

Choose the one you consider correct and record your choice in soft pencil on the separate OTAS Answer Sheet.

A copy of the Data Sheet 'Colours of Some Common Metal Hydroxides' is printed on page 15.

A copy of the Periodic Table is printed on Pg 16.

This document consists of **16** printed pages, including this cover page.

[Turn over

- 1 A pendulum clock uses the period of its oscillation to tell time.

Which one of the following does not affect its accuracy?

- 1 the length of the pendulum
- 2 the mass of the pendulum
- 3 the gravitational field strength of the clock's location
- 4 the material of the pendulum

- A 1 only
- B 2 only
- C 2 and 3
- D 2 and 4

- 2 The order of magnitude of a human hair is

- A 100 μm B 1.00 mm C 1.0 cm D 1.0 m

- 3 Refer to the following displacement-time graph of a car.

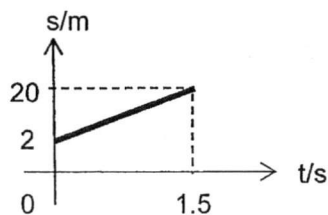

Which of the following is true?

- A The car is moving at a constant speed of 13.3 m/s.
- B The car is moving at a constant speed of 12 m/s.
- C The car is moving at a constant acceleration of 13.3 m/s.
- D The car is accelerating non-uniformly.

- 4 A boy throws a stone upwards into the air. Which of the following is true of the stone at the highest point?

- A The acceleration of the stone is zero.
- B The acceleration of the stone is approximately 10 m/s^2 .
- C The speed of the stone is approximately 10 m/s .
- D The speed of the stone is equal to the speed at which it is thrown up.

- 5 The following diagram shows the forces on a plane. The thrust T and drag D act horizontally on the plane. The weight W and lift L act vertically on the plane.

The plane is accelerating forward at a constant altitude.

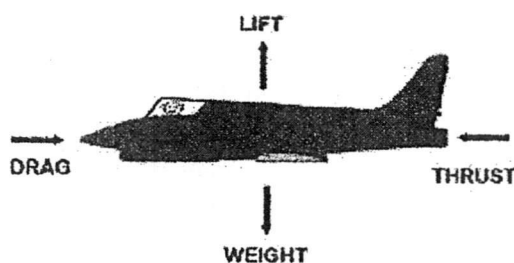

Which of the following description of the forces are true?

	horizontal forces	vertical forces
A	$D > T$	$L = W$
B	$T = D$	$L > W$
C	$T > D$	$L > W$
D	$T > D$	$L = W$

- 6 A mass experiences a constant resultant force.

Which of the following must be true of the motion of the mass?

- A It moves with constant acceleration.
 B It moves with constant speed.
 C It's velocity changes at a constant rate.
 D It's displacement changes at a constant rate.
- 7 A 100 g rock is weighed on Earth and Mars. The gravitational field strength of Mars is 2.6 times that of Earth's. Which of the following shows the mass and weight of the rock on Mars?

	mass on Mars	weight of Mars
A	100 g	100 g
B	100 g	0.26 N
C	100 g	2.6 N
D	260 N	260 N

4

- 8 The following diagram shows a stability toy bird. When displaced, it will always rock back to its original position.

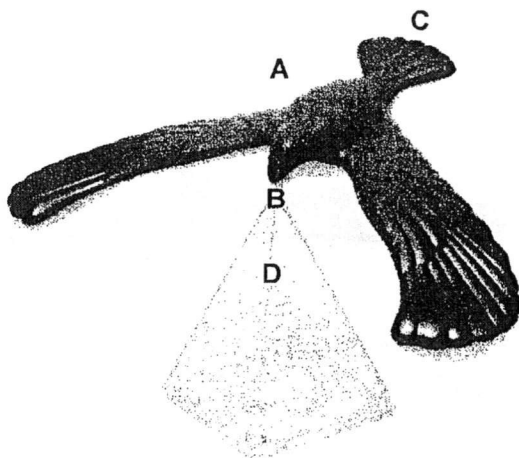

Which one of the above points shows the position of its centre of gravity?

- 9 The following diagram shows a water heating metal coil in a water container.

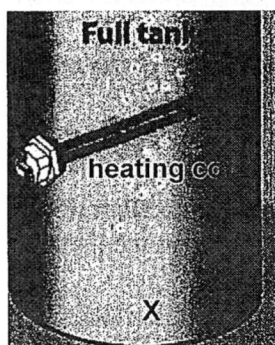

After 10 minutes, the water at position X still remains at room temperature. This is because

- A water is a poor conductor of heat.
- B the coil is a poor conductor of heat.
- C heated water rises in density and rises instead of sinks.
- D water is a good reflector of thermal radiation.

- 10 An X-ray is used in medical examination of bones because
- A it can travel very fast.
 - B it does not make any sound.
 - C it has a high frequency.
 - D it is sensitive to heat.
- 11 A man moves away from a plane mirror with a constant velocity of 20 cm/s. The distance between the man and his image in the mirror
- A decreases at 20 cm/s.
 - B decreases at 40 cm/s.
 - C increases at 20 cm/s.
 - D increases at 40 cm/s.
- 12 Which diagram shows a ray of light passing through a diverging lens?

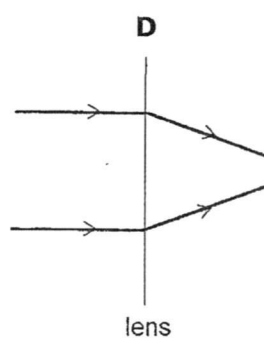
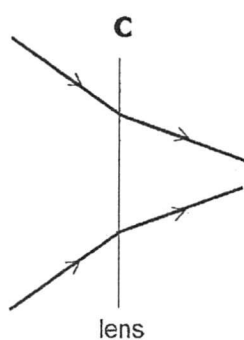
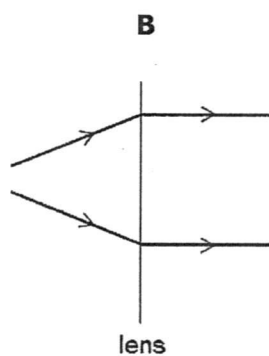
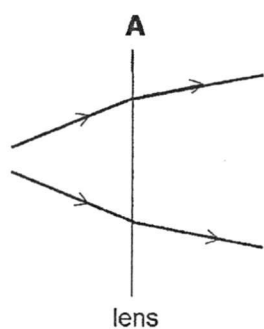

- 13 The following diagram shows an electric field between two charges. A positive test charge is placed between the field.

Which of the following shows the electric force experienced by the positive test charge?

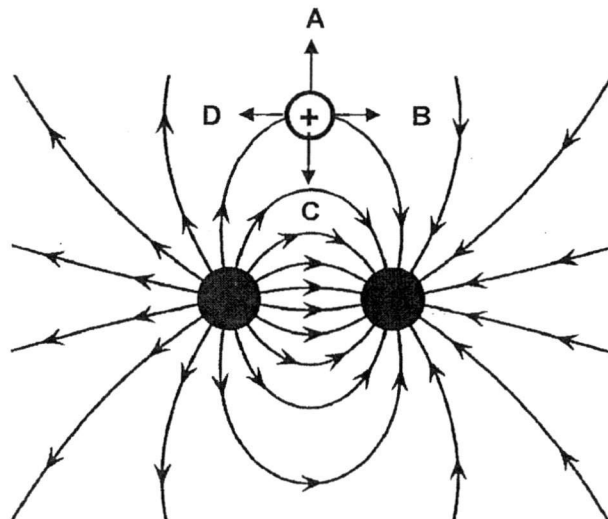

- 14 A wire with a resistivity of $2.7 \times 10^{-8} \Omega\text{m}$ is 2.0 m long and has a cross sectional area of 1.0 mm^2 . The resistance of the wire is
- A $1.4 \times 10^{14} \Omega$
 B $5.4 \times 10^{-8} \Omega$
 C $5.4 \times 10^8 \Omega$
 D 0.054Ω
- 15 Two resistors are connected to an electric cell with emf V .

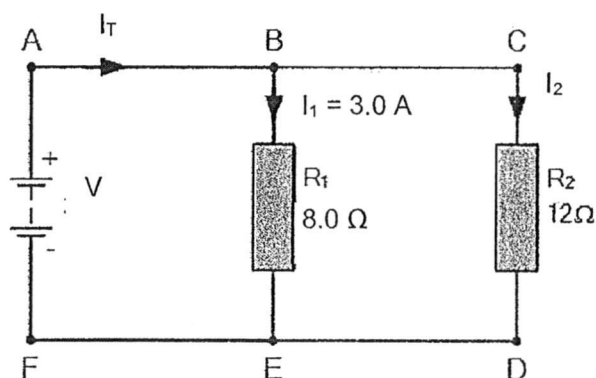

What is the current I_T ?

- A 2.0 A
 B 5.0 A
 C 6.0 A
 D 24 A

- 16 The following shows how the current I across a device changes as the potential difference V across it changes as well as how the potential difference V across the device changes as the current I through it changes.

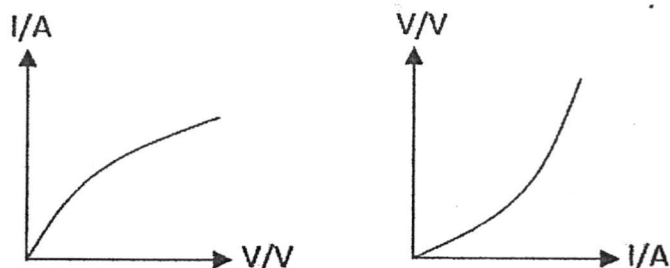

What is this device?

- A a semi-conductor diode
 - B a copper wire
 - C a filament lamp
 - D a rubber rod
- 17 Ian uses his room's air-conditioner 10 hours per day. The conditioner is rated at 240 V, 2000 W. Each unit of electricity costs \$0.24.
- The monthly (30 days) cost of using the air-conditioner is
- A \$3.45.
 - B \$60.00.
 - C \$144.00.
 - D \$345.60.
- 18 Which of the following explains why switches are connected to the live wire instead of the neutral wire?
- A current flows in the live wire instead of the neutral wire
 - B current flows through the live wire before the neutral wire
 - C current in the live wire is higher than that in the neutral wire
 - D the switch disconnects the high potential of the live wire

- 19 A permanent magnet is used to stroke a steel bar. Which of the following shows the poles formed at X and Y?

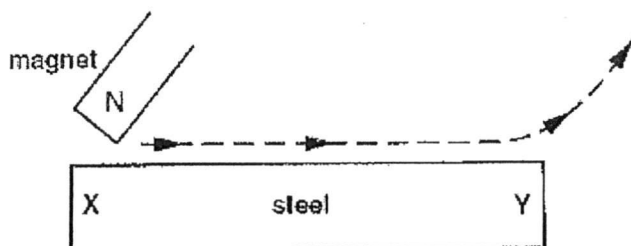

	pole at X	pole at Y
A	N	N
B	S	S
C	N	S
D	S	N

- 20 The following diagram shows a DC motor.

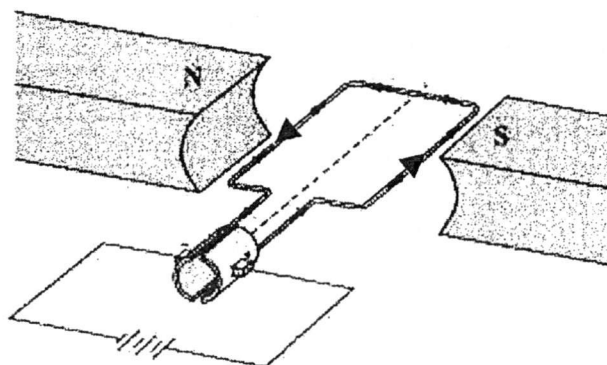

Which one of the following describes the motion of the coil?

- A moves upwards
- B moves downwards
- C rotates clockwise
- D rotates anti-clockwise



ZHONGHUA SECONDARY SCHOOL

Preliminary Examination 2017

CANDIDATE
NAME

	()
--	-----

CLASS

--	--	--

SCIENCE (PHYSICS)

5076/02

Paper 2 Theory

14 September, 2017

Secondary 4 Express/ 5 Normal (Academic)

1 hr 15 minutes

Set by: Mr Lawrence Tang

Vetted by: Mr Tan Jun Hong

READ THESE INSTRUCTIONS FIRST

Write your name, index number and class in the spaces at the top of this page and on all separate answer paper used.

Write in dark blue or black pen.

You may use a pencil for any diagrams, graphs or rough working.

Do not use staples, paper clips, highlighters, glue or correction fluid.

Section A

Answer **all** questions.

Write your answers in the spaces provided on the question paper.

Section B

Answer any **two** questions.

Write your answers in the spaces provided on the question paper.

The number of marks is given in brackets [] at the end of each question or part question.

All essential working must be shown clearly.

For Examiner's Use	
Section A	45
Section B	20
Total	65

This document consists of **19** printed pages, including this cover page.

Section A

[Turn over

Answer all the questions in the spaces provided.

- 1 Fig 1.1 shows scaled top view of a 160 g hockey ball that is struck by two hockey sticks with forces F_1 and F_2 .

Scale: 1.0 cm : 5.0 N

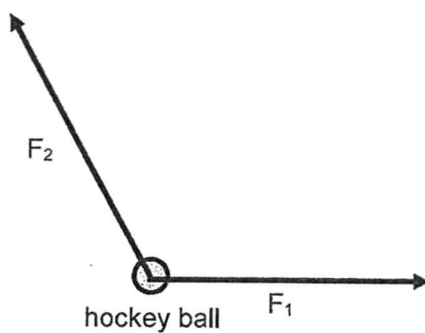

Fig 1.1

- (a) Complete Fig 1.1 to find the resultant force R on the hockey ball due to the two forces. Indicate its direction with respect to the horizontal.

$R = \dots\dots\dots$ N

direction = $\dots\dots\dots$ ° from horizontal [3]

- (b) Hence calculate the acceleration of the hockey ball.

acceleration = $\dots\dots\dots$ m/s² [1]

Total marks:	
--------------	--

[Turn over

2 Fig 2.1 shows a stone being thrown upwards at **A** from a cliff. It reaches the maximum height at **B** and falls to the bottom of the cliff at **C**.

Fig 2.2 shows how the speed of the stone changes from **A** to **C**.

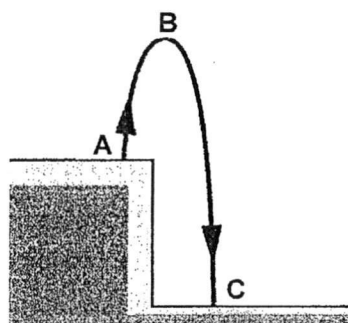

Fig 2.1

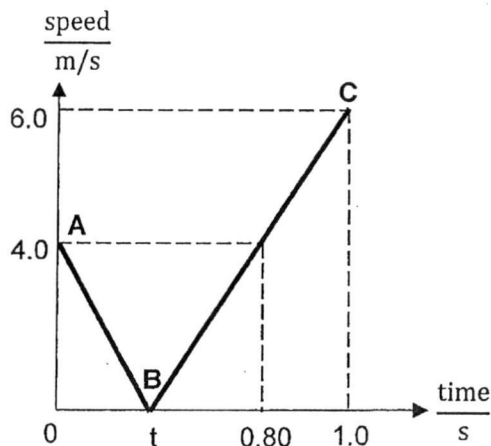

Fig 2.2

(a) The stone undergoes constant deceleration of 10 m/s^2 from **A** to **B**.

(i) Explain the term “constant deceleration”.

.....
 [1]

(ii) Explain in terms of forces why the stone has a constant deceleration of 10 m/s^2 from **A** to **B**.

.....

 [2]

(b) Hence, or otherwise, calculate time *t*, the time taken for the stone to go from **A** to **B**.

time *t* =s [1]

Total marks:	
--------------	--

[Turn over

4

- (c) Calculate distance **BC** and hence determine the height of the cliff.

distance BC = m

height of cliff = m [2]

- (d) Calculate the average speed from **B** to **C**.

average speed = m/s [1]

- 3 Fig 3.1 shows a rocket that has just launched and the forces acting on it.

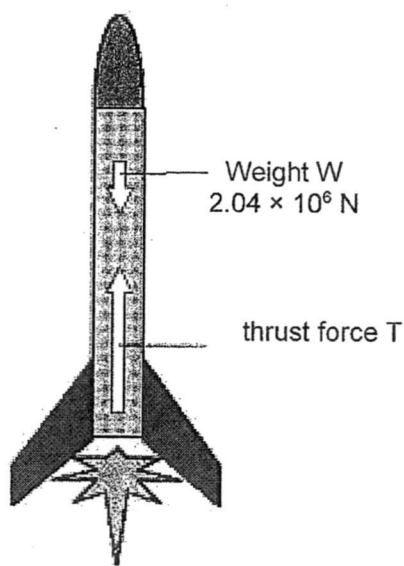

Fig 3.1

Total marks:	
--------------	--

[Turn over

5

- (a) The rocket has an acceleration of 15 m/s^2 at the instant shown. Calculate the net force acting on the rocket.

net force =N [1]

- (b) Hence calculate the upward thrust T acting on the rocket at the instant shown.

$T = \dots\dots\dots \text{ N}$ [2]

- (c) As the rocket accelerates, the air resistance that opposes the rocket motion increases. Describe and explain the effect of this on the acceleration of the rocket.

.....
.....
.....
..... [2]

Total marks:	
--------------	--

[Turn over

- 4 Mark is designing a clothes hanger using a hollow uniform 1.5 m aluminium rod as shown in Fig 4.1. The inner diameter is known to be 1.20 cm

Fig 4.2 shows the cross section of the rod. Fig 4.3 shows the Vernier reading of the outer diameter. The density of aluminium is 2.7 g/cm^3 .

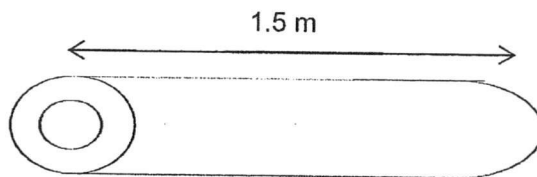

Fig 4.1

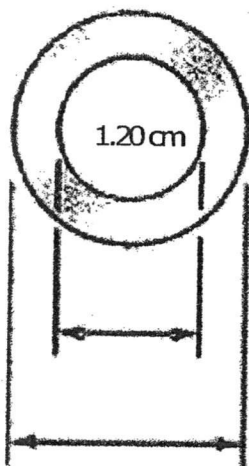

Fig 4.2

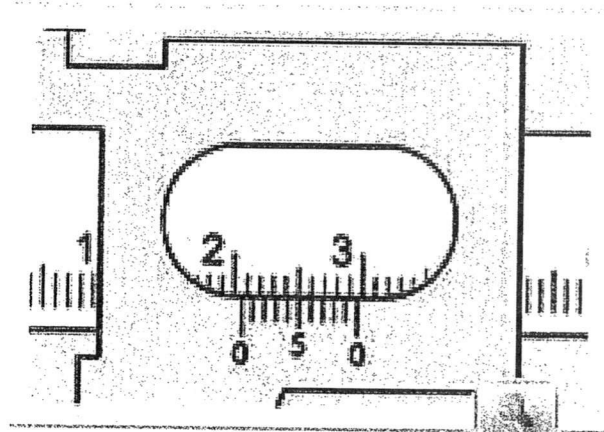

Fig 4.3

- (a) Calculate the volume of the rod and hence the mass of the 1.5 m rod.

volume of rod = cm^3 [3]

mass of rod = g [1]

Total marks:	
--------------	--

[Turn over

- (b) Fig 4.4 shows the side view of the same pole. A wet bed sheet with a mass of 2.0 kg is hung over the pole. The pole and bed sheet is hung out to dry and are at rest.

The centre of gravities of the rod and sheet is shown in Fig 4.4.

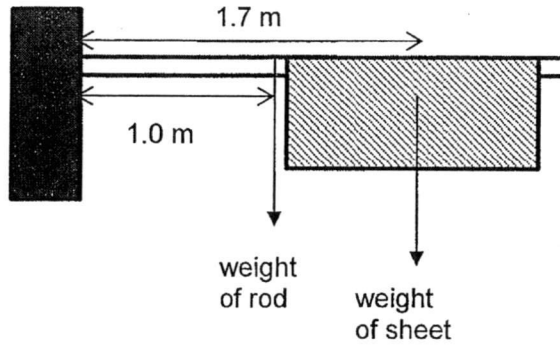

Fig 4.4

Calculate the sum of the moments about the hinge due to the weight of the rod and the sheet.

sum of moments = Nm [2]

- (c) An upward force U acts on the hinge. Calculate U and explain using Newton's First Law how you obtained your answer.

$U = \dots\dots\dots$ N

Explanation:

.....

..... [2]

Total marks:	
--------------	--

[Turn over

- 5 Fig 5.1 shows a pump in a hydroelectric plant that is used to transport water up a hill at night to a reservoir.

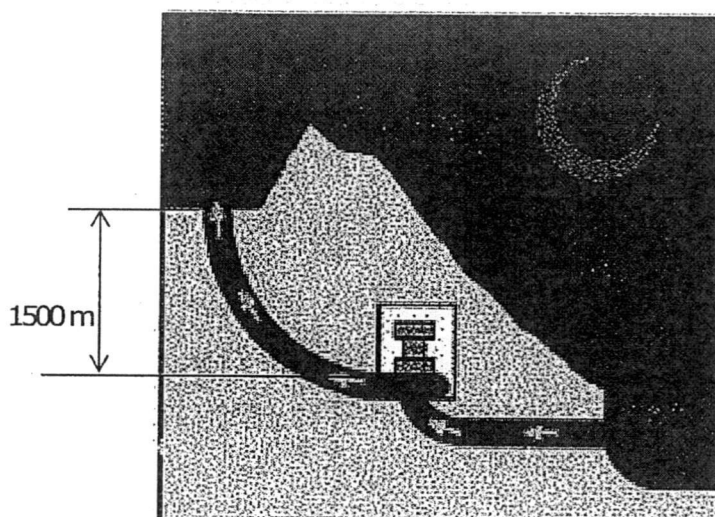

Fig 5.1

- (a) The pump handles 1.60×10^6 kg of water every second. Calculate the rate of work done by the pump in transporting the water to the reservoir.

rate of work done = J/s [2]

Total marks:	
--------------	--

[Turn over

- (b) Fig 5.2 shows the same hydroelectric plant where water from the reservoir is used to generate electricity in the day by turning turbines in the plant.

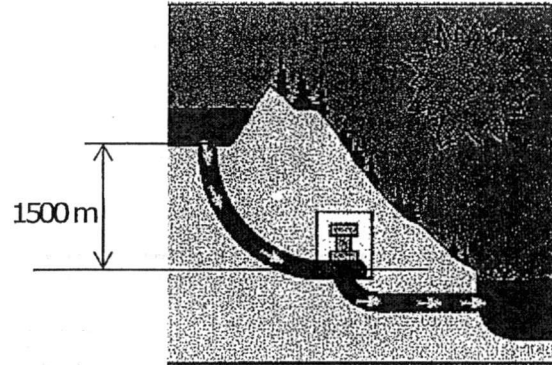

Fig 5.2

Given that 7.2×10^9 W of power is wasted due to frictional losses, calculate the rate of kinetic energy converted and hence the speed of the water just before it hits the turbines. Assume the turbine also handles 1.60×10^6 kg of water every second.

rate of kinetic energy = J/s

speed of water = m/s [3]

Total marks:	
--------------	--

[Turn over

- 6 Fig 6.1 shows the top view of a transverse water wave that travels a distance 22 m from A to B in 1.5 s. A particle X is on the wavefront A.

Fig 6.2 shows the front view of particle X.

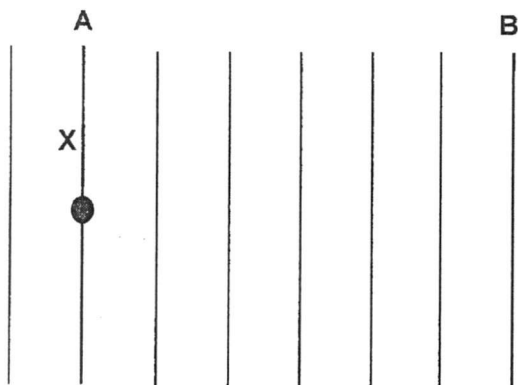

Fig 6.1

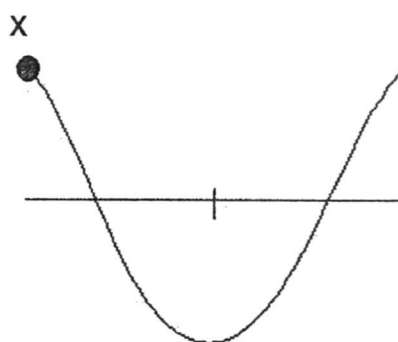

Fig 6.2

- (a) State what is meant by the term wavefront.

.....
 [1]

- (b) Explain why the water wave is considered a transverse wave.

.....
 [1]

- (c) Calculate the velocity, wavelength and frequency of the wave.

velocity = m/s

wavelength = m

frequency = Hz [3]

Total marks:	
--------------	--

[Turn over

- 7 Fig. 7.1 below shows a long block of glass over an object O. Light from O reaches the top surface of the glass at X, Y and Z. The refractive index of the glass is 1.5.

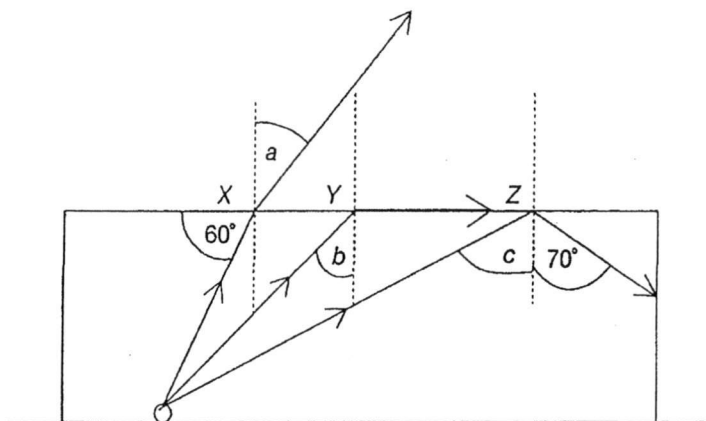

Fig. 7.1

- (a) Calculate the value of angle a.

angle a = ° [1]

- (b) Calculate the value of angle b.

angle b = ° [1]

- (c) State the value of angle c. and explain why the ray at point Z travels in the path as shown in Fig. 7.1.

angle c = °

explanation:

..... [1]

Total marks:	
--------------	--

[Turn over

- 8 Fig 8.1 shows the full scaled diagram of a converging lens with a focal length of 4.0 cm.

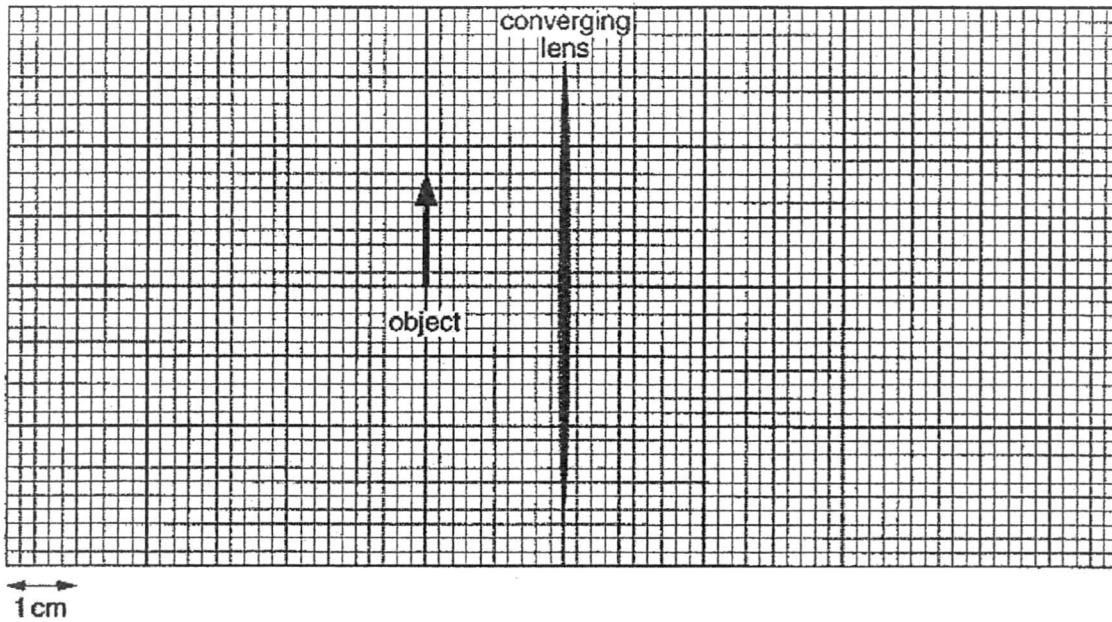

Fig 8.1

- (a) Draw two rays from the top of the object to locate the top of the image formed. Complete the diagram by drawing the whole image formed. [2]

- (b) State two changes to the image if the object is now placed 5.0 cm from the lens.

.....

.....

.....

..... [2]

Total marks:	
--------------	--

[Turn over

9 Fig 9.1 shows an electric kettle that is rated at 3.0 kW, 240 V.

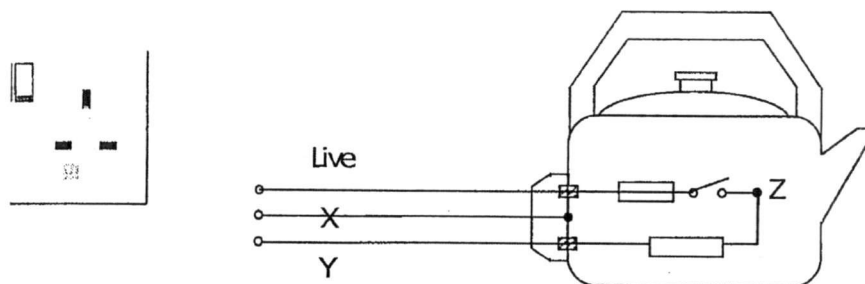

Fig 9.1

(a) Identify the wires X and Y.

X: Y: [1]

(b) Connect the live, X and Y wires to the correct points on the 3 pin electrical socket. [1]

(c) The live wire at point Z comes loose and the conducting wire touches the kettle metal casing. Describe how the safety feature(s) of the kettle reduce the possibility of electrocution.

.....

 [2]

End of Section A

Total marks:	
--------------	--

[Turn over

Section B

Answer any **two** questions in this section.

Write your answers in the spaces provided.

- 10 Fig 10.1 shows a solar oven that is used to heat a pot of water .

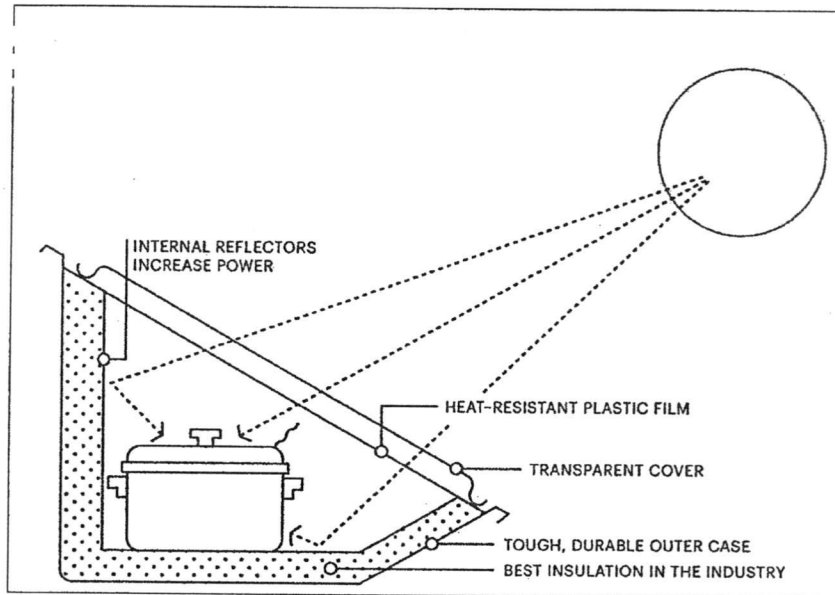

Fig 10.1

- (a) Describe and explain how the design of the oven allows the water to be heated up quickly.

.....

.....

.....

.....

.....

.....

..... [3]

Total marks:	
--------------	--

[Turn over

15

- (b) The air inside the pot is heated and expands. Describe the changes in the motion of the air molecules and the forces between them as they are heated.

.....

 [2]

- (c) The water evaporates initially before it finally boils. The temperature of the water remains constant during boiling but the temperature of the water changes during evaporation.

- (i) Define *boiling*.

.....
 [1]

- (ii) Explain why the temperature of the water remains constant during boiling in terms of its molecules.

.....

 [2]

- (d) The pot and the water has a total mass of 1.5 kg. The pot has a circular base of radius 20 cm.

Calculate the pressure in Pascals that the pot of water exerts on the floor.

pressure = Pa [2]

Total marks:	
--------------	--

[Turn over

- 11 Fig. 11.1 shows four resistors and three switches that are connected to a cell of emf 12 V in a circuit. Two switches S_1 and S_2 are closed while S_3 is open.

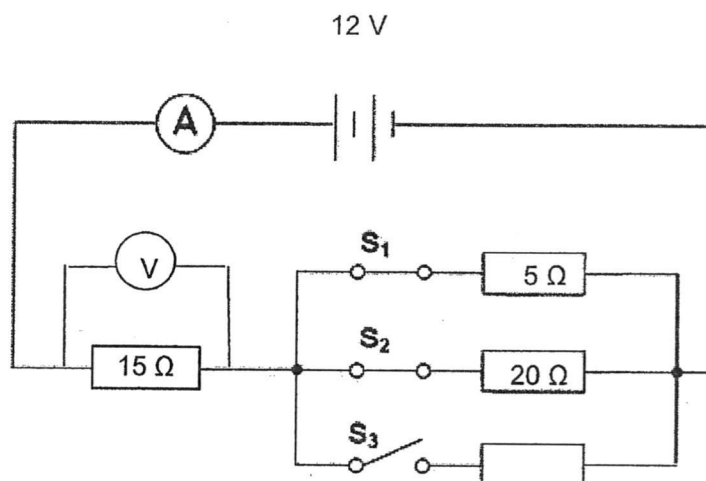

Fig 11.1

- (a) Explain what is meant by "emf of 12 V."

.....
 [1]

- (b) Calculate the total resistance of the circuit and hence the ammeter reading.

total resistance = Ω
 ammeter reading = A [3]

Total marks:

[Turn over

- (c) Calculate the amount of charges flowing through the cell per minute. Indicate the units clearly.

charge =
 unit = [2]

- (d) Hence calculate the energy used by the cell in a minute.

energy = J [1]

- (e) S_3 is now closed.

Predict and explain whether the voltmeter reading will increase, decrease or stay constant.

.....

 [2]

- (f) The $15\ \Omega$ resistor is an ohmic resistor. A potential difference (p.d) of 0 – 12 V is applied across it.

Sketch in Fig 11.2 below how the current I/A will change as the p.d V/V across it changes from 0-12 V. Show the V and I values clearly when a p.d of 12 V is applied across it.

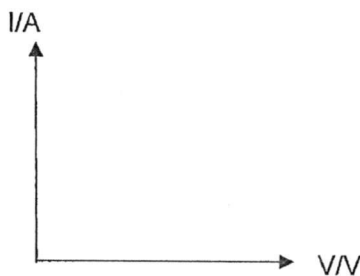

Fig 11.2

[1]

Total marks:	
--------------	--

[Turn over

- 12 Fig 12.1 shows an electric bell. When the switch is pushed down, the striker will hit the bell repeatedly.

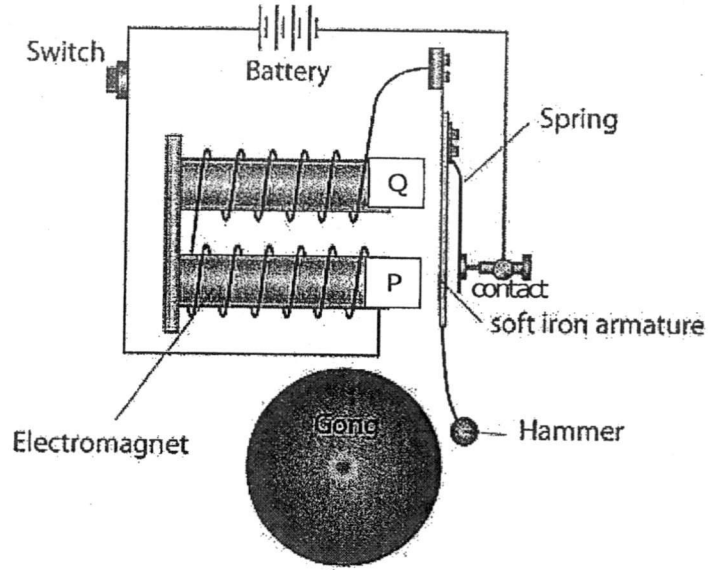

Fig 12.1

- (a) Identify poles P and Q.

P: Q: [1]

- (b) Explain how the bell will ring repeatedly when the push switch is closed.

.....

 [3]

- (c) Describe how longitudinal sound waves from the bell is propagated through the air.

.....

 [2]

Total marks:

[Turn over

- (d) Fig 12.2 shows the soft iron armature and the two magnets. Draw the magnetic field between them when the push switch is closed.

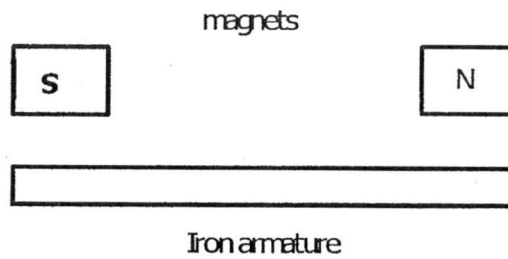

Fig 12.2

[2]

- (e) Fig 12.3 shows a current-carrying wire between two permanent magnets. When the switch is closed, the wire XY moves.

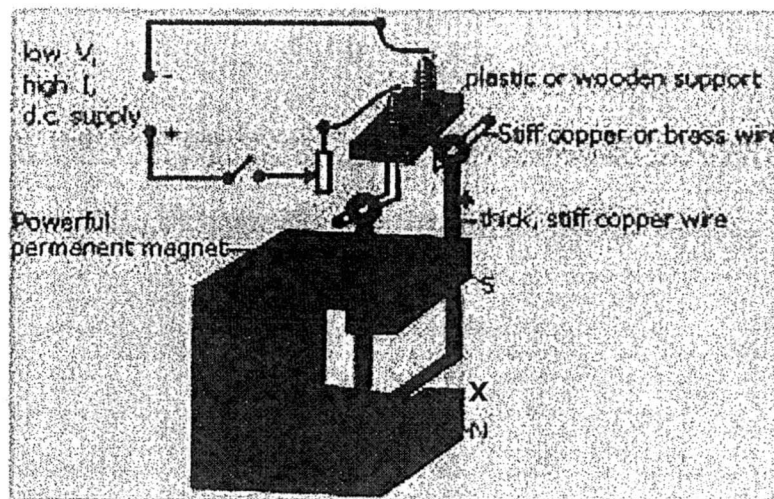

Fig 12.3

Describe and explain the motion of the wire XY.

.....

.....

.....

..... [2]

----- END OF PAPER -----

Total marks:	
--------------	--

ZHSS 2017 SC PHYSICS SEC 4E/5N 5076 Prelim Answers

1	D	11	D
2	A	12	C
3	B	13	B
4	B	14	D
5	D	15	B
6	C	16	C
7	C	17	C
8	D	18	D
9	A	19	C
10	C	20	C

2017 SEC 4E 5076 Prelim

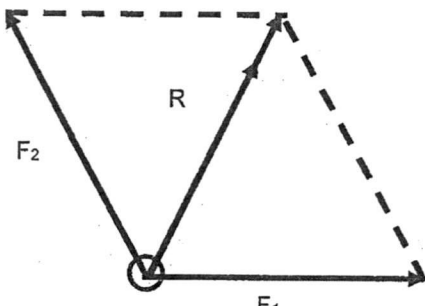
Qn	Answer	Marks
1a)	 <p> $R = 4.3 \times 5 = 21.4 \text{ N}$ (accept 20.3 -22.5 N) Direction = 63° from horizontal (accept 61° to 65°) </p>	Diagram Label and double arrow -1 Force - 1m Direction - 1 m
b)	$a = \frac{F}{m} = \frac{18}{0.16} = 113 \text{ m/s}^2$	1
2ai)	Constant decrease in velocity per unit time	1
ii)	Deceleration as net force (weight) is downwards while motion is upwards (or opposes motion) Deceleration is constant as net force = weight = constant	1 1
b)	Gradient = - 10 $-4.0/t = -10$ $t = 0.40 \text{ s}$	1
c)	Distance BC = area under v-t graph = $\frac{1}{2} (1-0.40)(6) = 1.8 \text{ m}$ Height of cliff = BC - AB = $1.8 - \frac{1}{2} (0.40)(4.0) = 1.0 \text{ m}$	1 1
d)	Average speed = $1.8 / 0.6 = 3.0 \text{ m/s}$	1

3a	Net force $F_{\text{net}} = ma = (2.04 \times 10^5)(15) = 3.06 \times 10^6 \text{ N}$	1
b	$T - W = F_{\text{net}}$	1
	$T = W + F_{\text{net}}$ $= 2.04 \times 10^6 + 3.06 \times 10^6 = 5.1 \times 10^6 \text{ N}$	1
c	Acceleration decreases	1
	As $F_{\text{net}} = T - W - R$ And as R increases, F_{net} decreases	1
4a	Thickness = OD - ID	
	Vernier reading = 2.05 cm (accept 2.06 cm)	1
	Volume = cross sectional area X length $= \frac{\pi}{4}(2.05^2 - 1.20^2)(150) = 325 \text{ cm}^3$	1 1
	Mass = volume X density = $325 \times 2.7 = 879 \text{ g}$	1
b)	Moments $= m_{\text{rod}}g(d_{\text{rod}}) + m_{\text{sheet}}g(d_{\text{sheet}})$ $= (0.879)(10)(1.0) + 2.0(10)(1.7)$ $= 8.79 + 34$ $= 42.8 \text{ Nm}$	1 1
	c)	$U = W_{\text{rod}} + W_{\text{sheet}}$ $= 8.79 + 20$ $= 28.8 \text{ N}$
	Newton's 1 st Law implies since the rod is at rest. that if F_{net} is zero, hence $F_{\text{up}} = F_{\text{down}}$ and $U = \text{total weight of rod and sheet}$	1
5a)	Rate of work done = $mgh / t = (m/t) g h = (1.60 \times 10^6)(10)(1500)$ $= 2.4 \times 10^{10} \text{ J/s}$	
b)	GPE converted to KE and heat loss	
	In 1 second: GPE = KE + 7.2×10^9 $2.4 \times 10^{10} = \text{KE} + 7.2 \times 10^9$ KE = $1.68 \times 10^{10} \text{ J/s}$	1
	$\frac{1}{2}(1.6 \times 10^6)v^2 = 1.68 \times 10^{10}$ $v = 145 \text{ m/s}$	1 1
6a	The imaginary line through all points on a wave that are in phase	1
b	The water particle moves in a direction perpendicular to the direction of wave motion	1
c	$v = d / t = 22 / 1.5 = 14.7 \text{ m/s}$	1
	wavelength = $22 / 6 = 3.67 \text{ m}$	1
	frequency = velocity / wavelength = $14.7 / 3.67 = 4.0 \text{ Hz}$	1
7a	$n = \sin i / \sin r$ $1.5 = \sin a / \sin 30^\circ$ $a = 48.6^\circ$	1
b	B = critical angle = $\sin^{-1}(1/1.5) = 41.8^\circ$	1
c	70°	1
	Total internal reflection occurs as angle i of $70^\circ > c$ angle of 41.8°	1

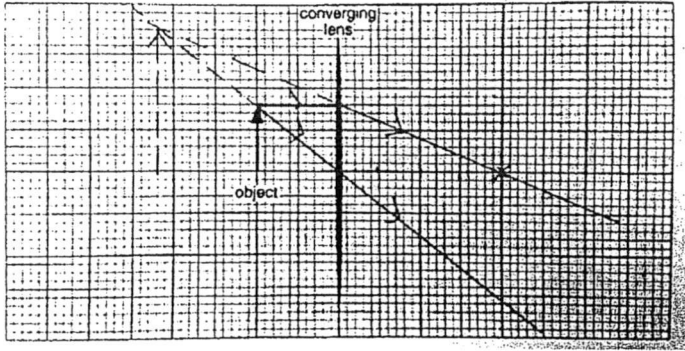
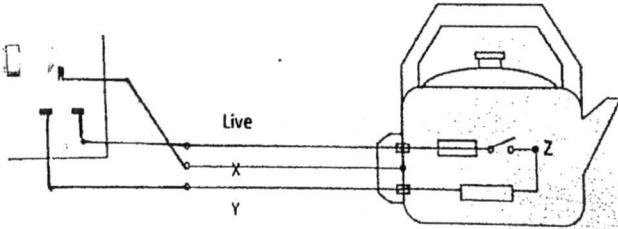
8a		2
8b	<p>(Upright, virtual magnified image to inverted real magnified image)</p> <p>From virtual to real image From upright to inverted image From image being on same side of lens as object to opposite side of lens (any 2)</p>	1 1
9a)	<p>X – earth (as it touches metal casing) Y = neutral wire</p>	1
b)		1
c	<p>If a person touch the metal case, the earth wire <u>diverts the current to the ground instead of the person</u></p> <p>The high current <u>blows the fuse</u> and <u>disconnects kettle from the high voltage supply</u></p>	1 1

Section B

10a)	<p>1. Transparent cover allows thermal radiation to enter the pot. 2. Reflectors increase the rate of thermal radiation absorption by pot. 3. Insulation at the base/plastic film reduces rate of heat loss by conduction from the pot</p>	1 1 1
b)	<p>Air molecules move faster (or increase in speed) The forces between molecules decrease.</p>	1 1
c)i)	<p>The process where liquid becomes gas without a change in temperature</p>	1
ii)	<p>Heat absorbed is used to <u>overcome the inter-molecular forces of attraction</u> and the <u>atmospheric pressure</u> The <u>kinetic energy</u> and hence temperature does not change, only the potential energy changes</p>	1 1
d)	<p>$A = \pi r^2 = \pi(20 \times 10^{-2})^2 = 0.126 \text{ m}^2$</p>	1

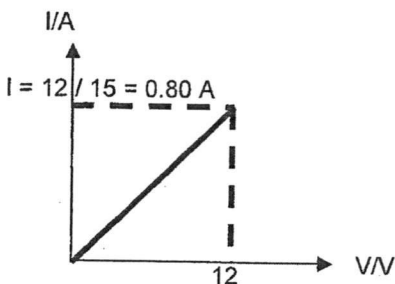
	$P = F/A = (1.5)(10) / 0.126 = 119 \text{ Pa}$	1
11a)	The work needed to move a unit charge across the circuit	1
b)	$R = 15 + \left(\frac{1}{5} + \frac{1}{20}\right)^{-1} = 15 + 4 = 19 \Omega$ Ammeter reading = $12/19 = 0.632 \text{ A}$	2 1
c)	$Q = It = (0.632)(1 \times 60) = 37.9$ Coulombs	1 1
d)	$E = VQ = 12(37.9) = 455 \text{ J}$	1
e)	When switch is closed, a resistor is added in parallel and the <u>total R decreases</u> . The <u>total current increases</u> . <u>Voltmeter reading increases</u> as $V = IR$.	1 1
f)		1
12a)	P - N, Q - S	1
b)	Current flow <u>magnetizes two iron core</u> The iron arm becomes an <u>induced magnet and is attracted</u> . Striker hits gong. <u>Contact is broken</u> , spring pulls arm back to close circuit to <u>start current</u> . Cycle repeats.	1 1 1 1
c)	Bell <u>vibrates</u> Air molecules <u>push and pull on each other</u> to set up a series of compressions and rarefactions	1 1
d)	See diagram	1 pattern 1 arrow
e)	Wire XY deflects to the right The magnetic field of the permanent magnet interacts with the magnetic field of the current to produce a force	1 1