



CATHOLIC HIGH SCHOOL
PRIMARY 6
PRELIM 2
EXAMINATION 2012

SCIENCE
EM 1 / EM 2

Name: _____ ()

Class : Primary 6

Date : 27 August 2012

BOOKLET A

30 Questions
60 Marks

Total Time for Booklets A & B : 1 hour 45 minutes

Instructions to Candidates

Do not open this booklet until you are told to do so.

Follow all instructions carefully.

Answer all questions.

Section A: Multiple Choice Questions (60 marks)

For each question from 1 to 30, four options are given. One of them is the most suitable answer. Make your choice (1, 2, 3 or 4) on the Optical Answer Sheet.

1. Which of the following graphs shows correctly the relationship between the mass of the seed leaves and the height of the seedling as a seed germinates to become a young plant?

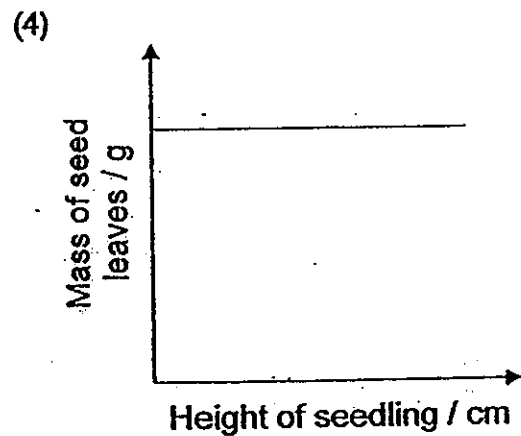
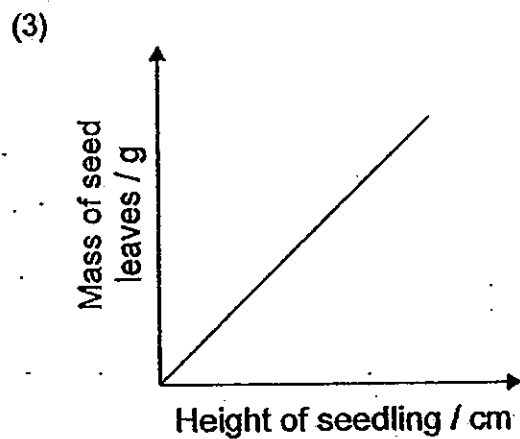
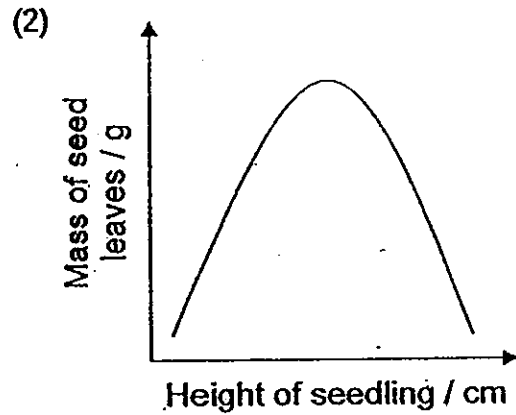
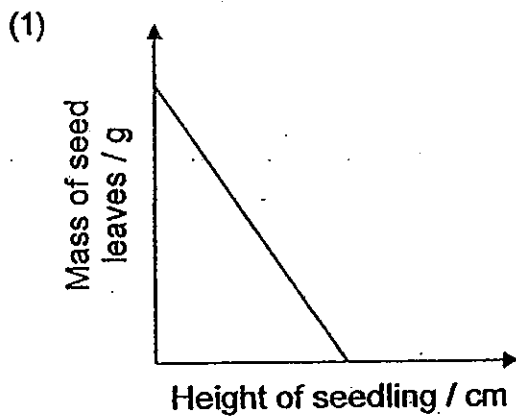

2. The dichotomous key below shows the characteristics of some animals.

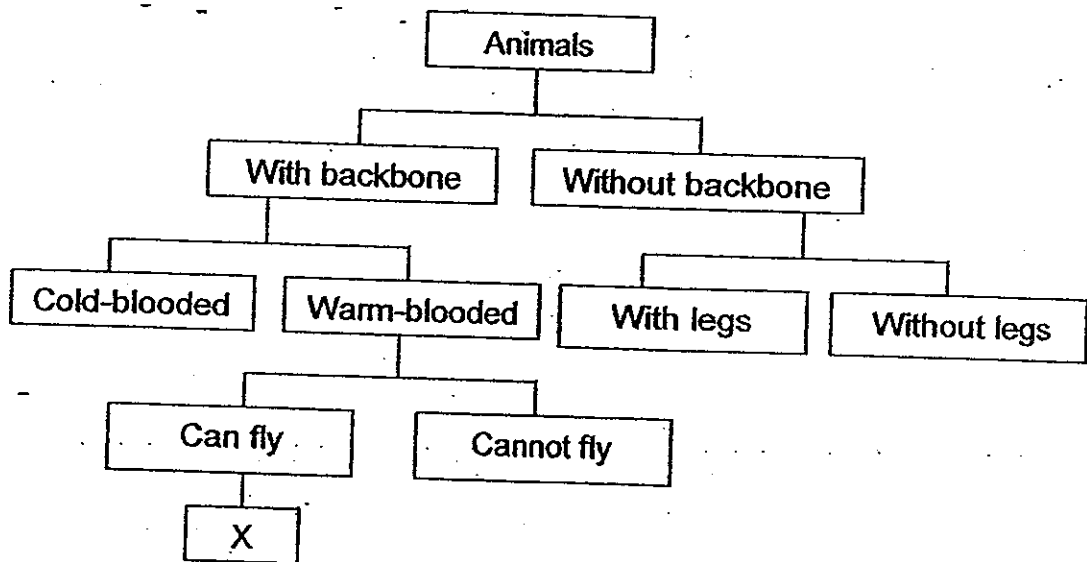

Which of the following group(s) of animals represent(s) X?

- A Bird
 - B Insect
 - C Reptile
 - D Mammal
- (1) A only
(2) A and C only
(3) A, B and D only
(4) None of the above

3. Look at the diagram of a human digestive system below.

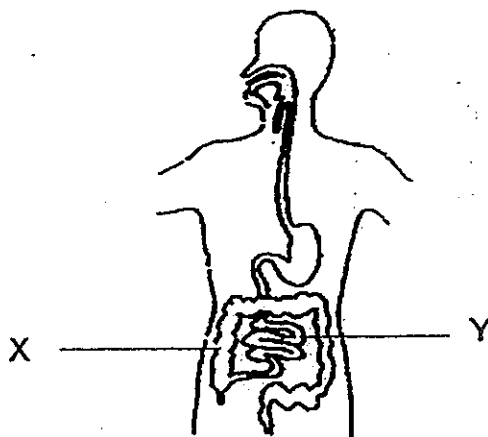

Which of the following correctly shows what happens at X and Y?

X		Y	
Absorption of water	Absorption of digested food	Absorption of water	Absorption of digested food
(1) No	Yes	Yes	No
(2) No	Yes	No	Yes
(3) Yes	No	No	Yes
(4) Yes	No	Yes	No

4. Melvin covered a plant with a bell jar which was painted black. He kept the plant in a dark room for 24 hours before he conducted the experiment.

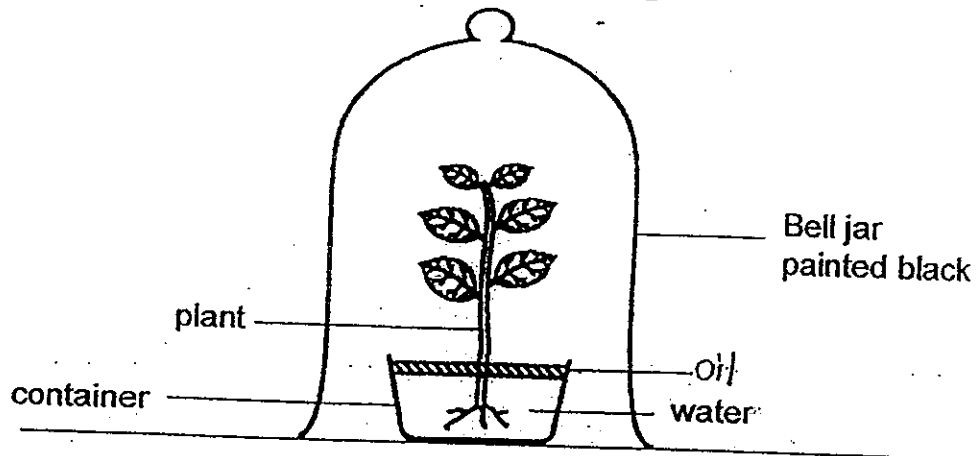

Which of the following shows the changes in the bell jar after two hours?

	Water vapour	Oxygen	Nitrogen	Temperature
(1)	Increased	Decreased	Increased	Decreased
(2)	Increased	Decreased	Remained the same	Increased
(3)	Decreased	Increased	Remained the same	Increased
(4)	Decreased	Increased	Decreased	Decreased

5. The diagram below shows how blood is circulated in our body.

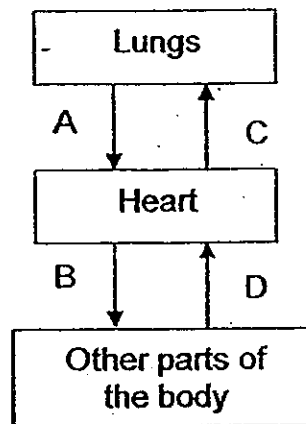

Four blood samples were taken at the same time from four different blood vessels in the body. The graph below shows the amount of oxygen in the four blood samples.

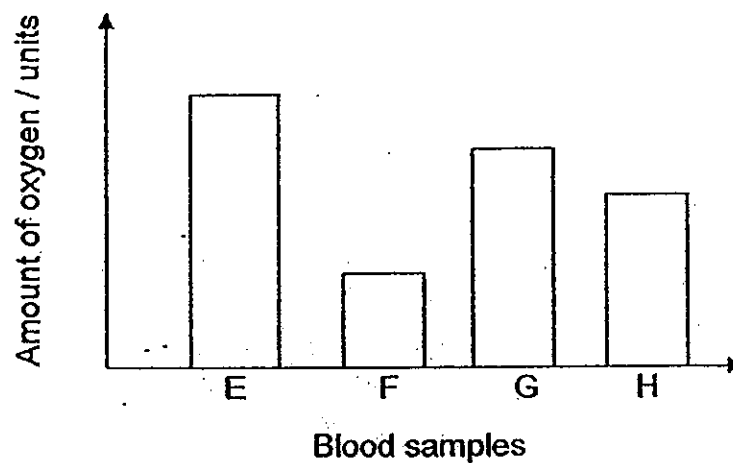

Which blood samples shown in the graph were most likely taken from parts A and B of the circulatory system shown in the diagram above?

- (1) E and G
- (2) E and H
- (3) F and G
- (4) F and H

6. The diagram below shows two cells, M and N.

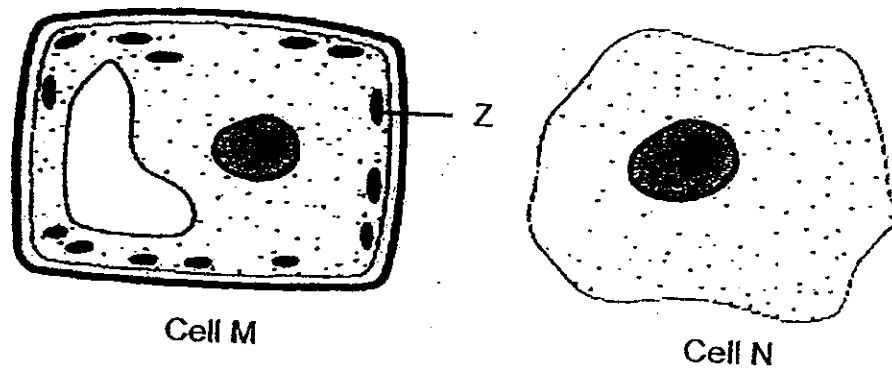

A scientist managed to successfully transfer Part Z in cell M to cell N. He found that this new cell N produced sugar when placed in a brightly-lit environment. Which of the following would also take place in cell N?

- A Cell N would produce oxygen.
- B Cell N would have a more regular shape.
- C Cell N would be able to undergo cell division.
- D Cell N would start to produce large vacuoles.

- (1) A only
- (2) A and D only
- (3) B and C only
- (4) C and D only

7. The diagram below shows the cross-section of a flower.

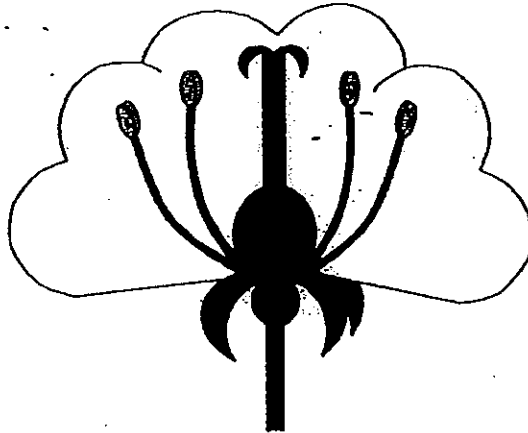

Based on the above diagram, identify the correct method of pollination for this flower and its corresponding characteristic.

	Method of Pollination	Characteristic
(1)	Wind	The flower has large petals to help to trap pollen.
(2)	Wind	The female reproductive part is longer than the male reproductive parts.
(3)	Insect	Both the female and male reproductive parts are present.
(4)	Insect	The reproductive parts are hidden in the flower.

8. The diagram below shows the family tree of Mei Ling.

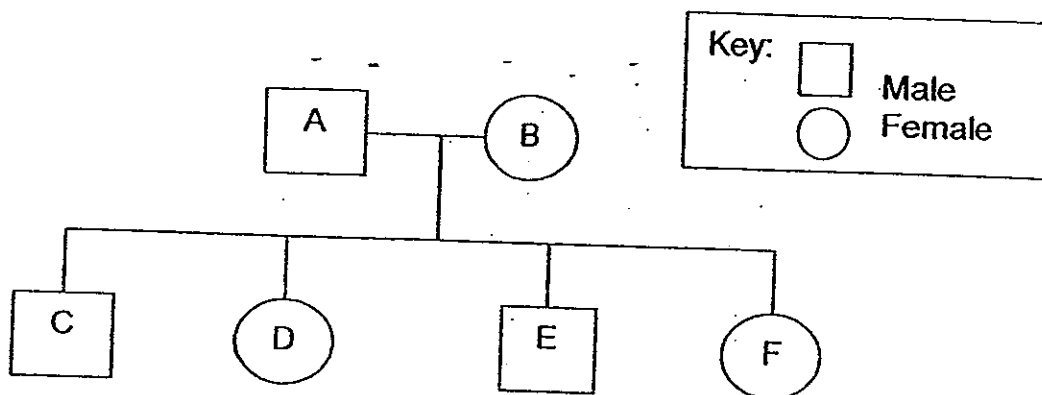

The table below shows the physical characteristics of each of Mei Ling's family members, including Mei Ling.

Key: ✓ characteristic present
 X characteristic absent

Family members	Characteristics			
	Straight hair	Detached ear lobes	Double eyelids	Dimples
A	✓	X	X	✓
B	X	✓	✓	X
C	✓	✓	X	✓
D	✓	X	✓	✓
E	X	✓	✓	X
F	✓	X	X	✓

Mei Ling inherited all the characteristics from one parent. Based on the above information, which letter, C, D, E or F represents her?

- (1) C
- (2) D
- (3) E
- (4) F

9. John took 3 identical containers, A, B and C, and filled each with the same amount of water. Then he put one plant in B and another similar plant with the roots cut off in C as shown below. All 3 containers were covered and left near a window for 4 days.

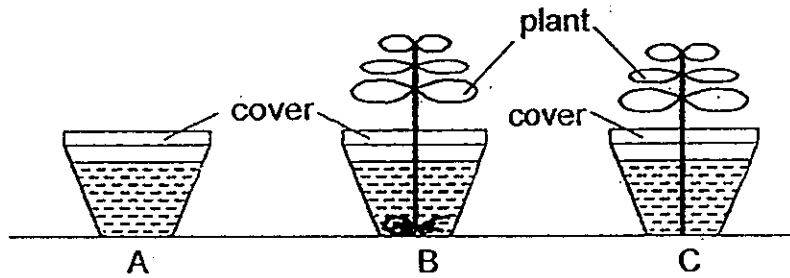

Which one of the following set of results would he expect to see at the end of the experiment?

(1)

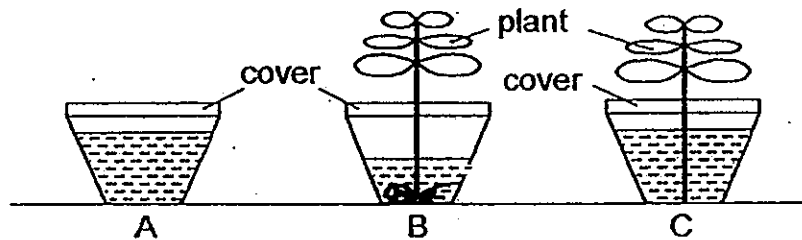

(2)

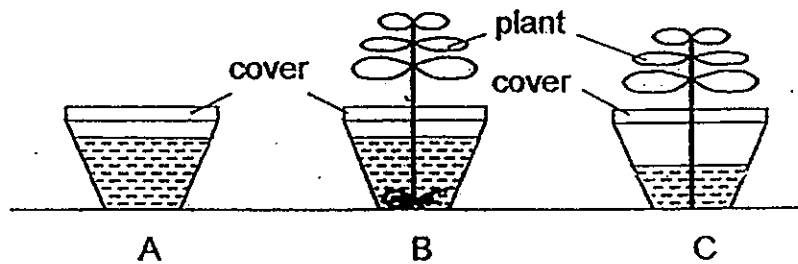

(3)

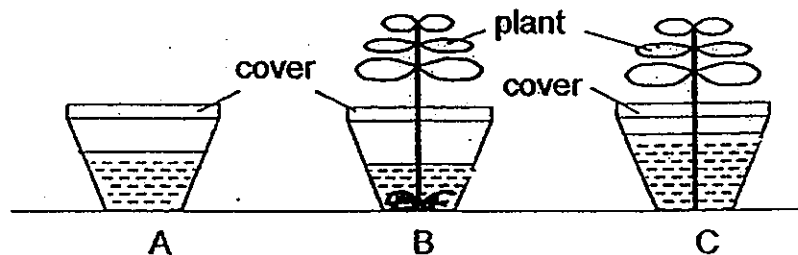

(4)

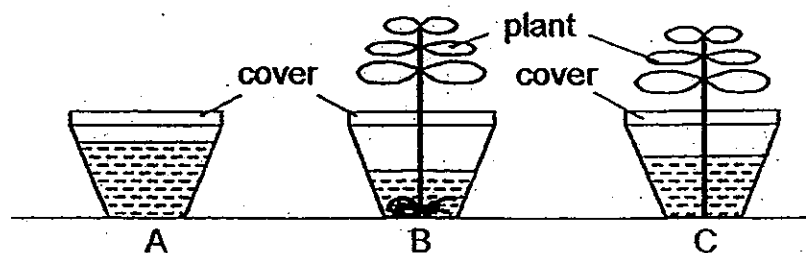

10. The classification table below shows the breathing methods of some aquatic animals and the type of oxygen they take in.

Animals	Method of obtaining oxygen				Type of oxygen	
	Breathing tubes	Gills	Moist skin	Trapping air bubble	Atmospheric	Dissolved
Mosquito larva	√				-√	
Water spider				√		√
Guppy		√				√
Tubifex worm			√			√

Which one of the aquatic animals is not correctly classified?

- (1) Guppy
- (2) Water spider
- (3) Tubifex worm
- (4) Mosquito larva

11. Alvin counted the number of organisms in a habitat. He recorded his observations in the table below.

Type of organism	Number of organism
Butterfly	5
Frog	3
Dragonfly	2
Fish	12
Kingfisher	2
Dragonfly nymph	6
Mosquito larva	8
Water lotus	4
Water hyacinth	6
Arrowhead	2

Based on the information in his table, which of the following statements are incorrect?.

- A There is only one community.
- B There are 2 types of dragonflies.
- C There are at least 9 populations.
- D There are 7 populations of animals.

- (1) A and C only
- (2) C and D only
- (3) B and D only
- (4) B, C and D only

12. Joseph collected three different soil samples, X, Y and Z. He poured 50g of soil sample X onto a filter paper in the funnel and poured 100 ml of water onto the soil sample as shown below.

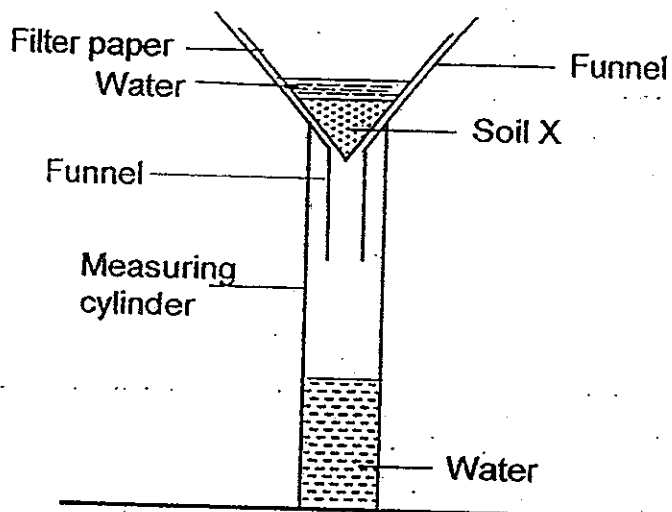

He measured and recorded the amount of water collected in the measuring cylinder for 15 minutes after the first drop of water flowed out from the funnel into the beaker.

He repeated the experiment with Soil Y and Z. The results are tabulated below.

Soil Sample	Amount of water collected after 15min/ml
X	55
Y	32
Z	80

From the results above, arrange Soil X, Y and Z on their ability to retain water in ascending order.

- (1) Z, Y, X
- (2) Y, Z, X
- (3) Z, X, Y
- (4) Y, X, Z

13. The diagram below shows a food web among several organisms in a pond.

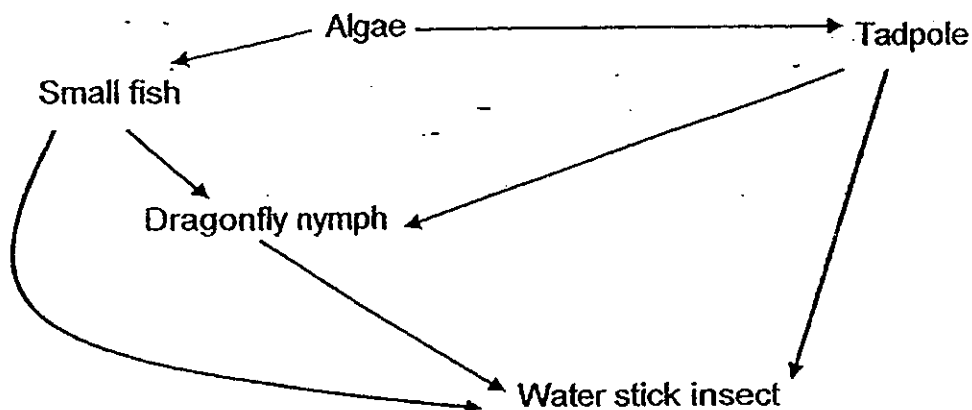

When all the tadpoles develop into frogs, which one of the following will take place?

- (1) Water stick insects will eat algae.
 - (2) Dragonfly nymphs will eat more fish.
 - (3) There will be a sharp increase in the number of dragonfly nymphs.
 - (4) There will be a sharp increase in the number of water stick insects.
14. The desert is a dry and arid place where water is scarce. Which of the following show(s) the structural adaptation(s) of camels that help(s) them to survive well in a desert?

- A Long eyelashes
- B Humps which store water
- C Produce concentrated urine
- D Drink as much water as possible when there is a water source

- (1) A only
- (2) A and B only
- (3) A, C and D only
- (4) A, B, C and D

15. The diagrams below show the teeth of Animal M and Animal N.



Animal M

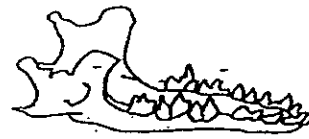

Animal N

Based on the diagrams above, which of the following statements are definitely true?

- A Animal M lives in a herd.
- B Animal M is an omnivore.
- C Animal N hunts in a group.
- D Animal N eats only animals.

- (1) D only
- (2) A and C only
- (3) B and D only
- (4) A, B and D only

16. Bella wanted to use the following set-up to determine the flexibility as well as the strength of 3 similarly-sized rods made of different materials.

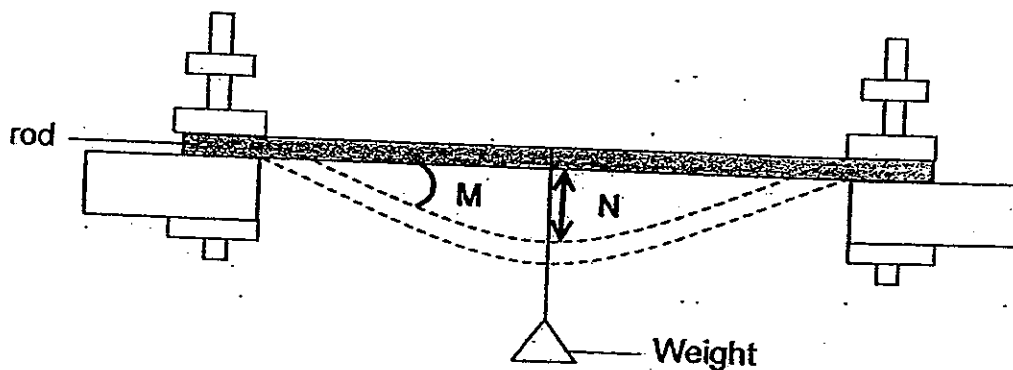

Which one of the following pairs of variables must she measure to enable her to determine the flexibility and strength of the rods?

	Flexibility	Strength
(1)	Angle M	Distance N
(2)	Distance N	Angle M
(3)	Distance N	Mass of Weight
(4)	Mass of Weight	Distance N

17. Look at the diagram carefully.

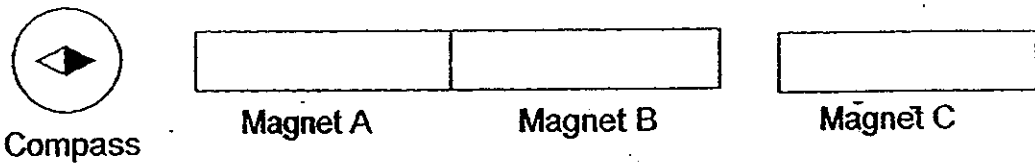

When the three bar magnets are placed near each other, magnet A and B are attracted to each other but magnet B and C repel each other.

Which of the following diagrams shows the correct poles for Magnet A and Magnet C?

(1)

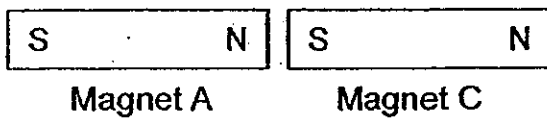

(2)

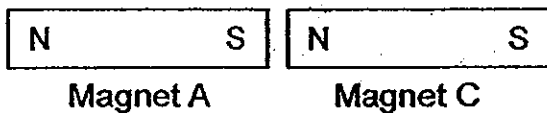

(3)

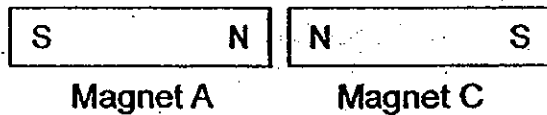

(4)

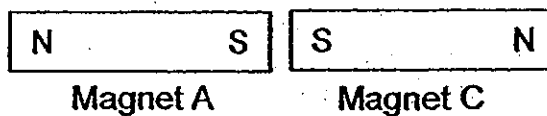

18. Susie wanted to magnetise a steel bar XY. Her friend suggested some ways to magnetise the steel bar as shown below.

A

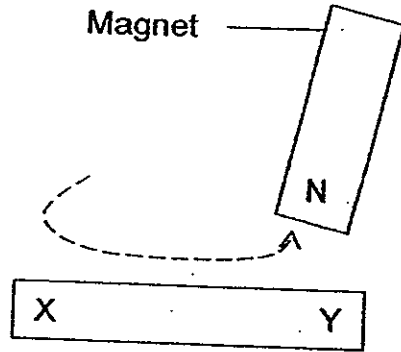

B

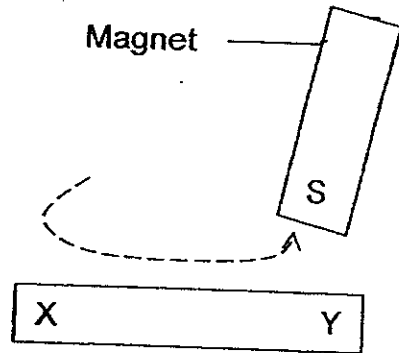

C

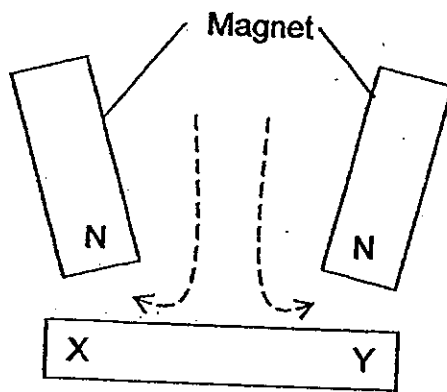

D

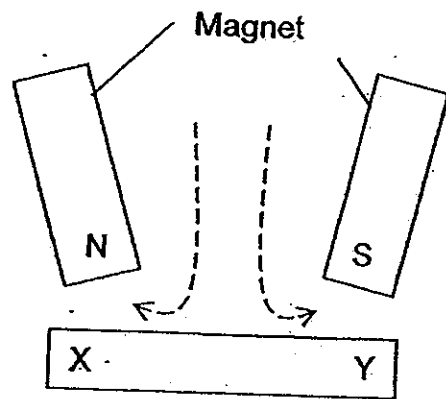

Which methods can she use to magnetise steel bar XY if she wants side Y to be the North pole?

- (1) A only
- (2) B only
- (3) A and C only
- (4) B and D only

19. The diagram below shows a 300 cm^3 container containing 100 cm^3 of water and a metal ball of volume 50 cm^3 . The container is connected to a pump containing 100 cm^3 of air. When the plunger is pushed halfway down, the air in the pump goes into the container.

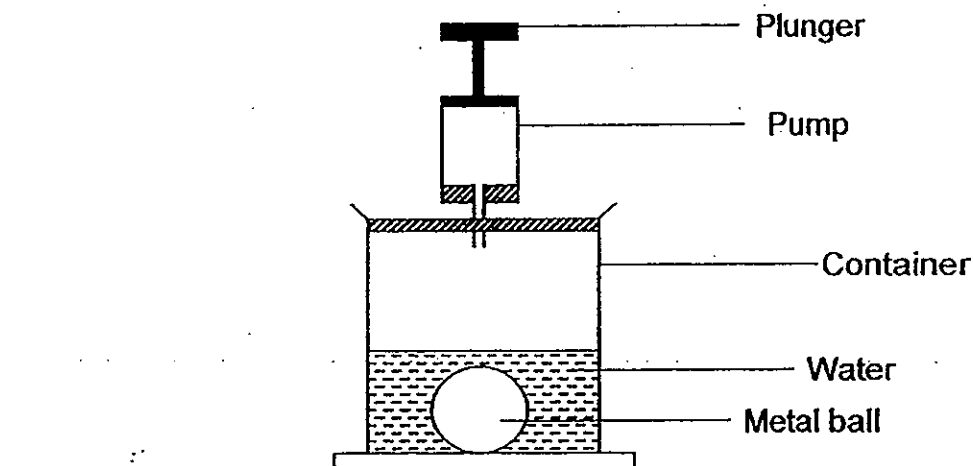

What is the volume of air in the container?

- (1) 50 cm^3
 - (2) 100 cm^3
 - (3) 150 cm^3
 - (4) 200 cm^3
20. The diagram below shows two beakers on a lever that is balanced.

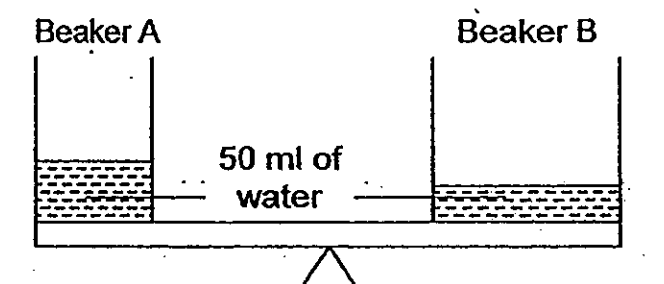

The set-up was left under the Sun for one hour. Which of the following will be observed after an hour?

- (1) The lever remains balanced.
- (2) The lever will tilt downwards at Beaker A.
- (3) The lever will tilt downwards at Beaker B.
- (4) The water level in beaker B will be higher than the water level in beaker A.

21. A pure solid, X, is heated until it melts. It is then further heated until it becomes a vapour as shown in the diagram below.

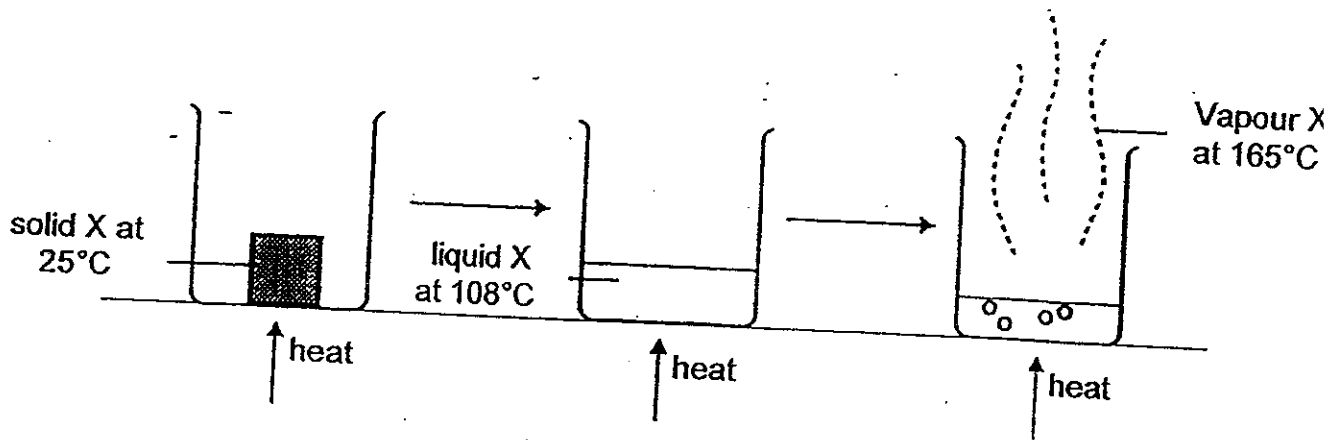

Which of the following statements is correct about substance X?

- (1) The freezing point of X is below 25°C .
 - (2) The boiling point of X is above 165°C .
 - (3) The melting point of X is below 108°C .
 - (4) The melting point of X is above 108°C .
22. Wayne placed a torch at position Q and an object at position S to cast a shadow on the screen.

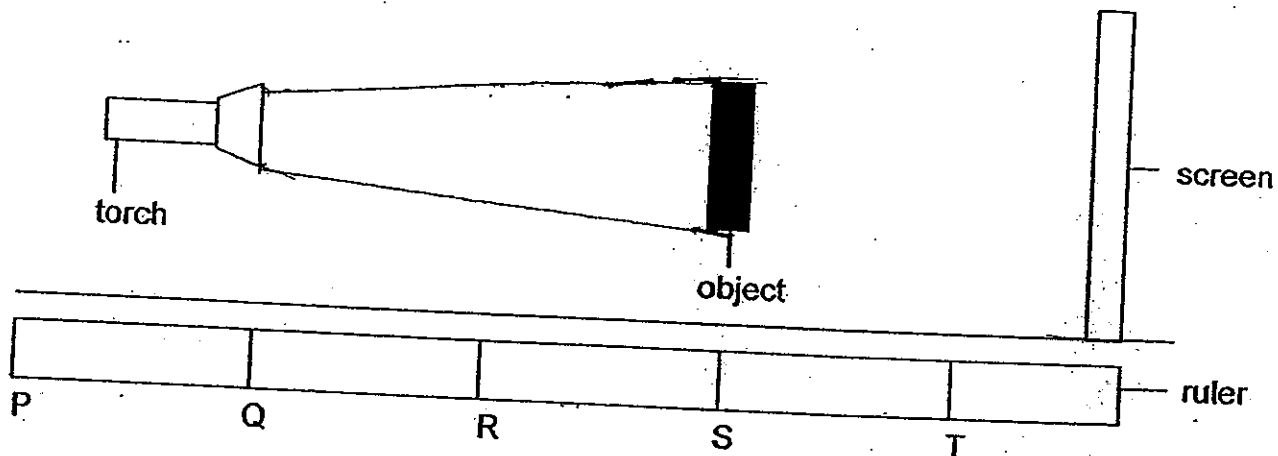

At which positions, P, Q, R, S and T on the ruler should the torch and the object be placed such that a larger shadow would be cast on the screen?

	Position of torch	Position of object
(1)	R	T
(2)	Q	T
(3)	R	S
(4)	P	S

23. 2 steel balls, P and Q, of different masses were put into a beaker of water. The beaker containing the balls was heated till the water boiled.

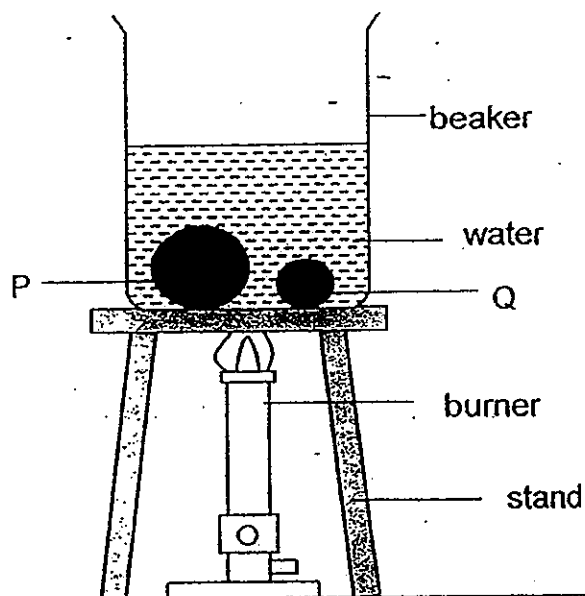

Based on the experiment above, which of the following statements about the steel balls are correct?

- A P is hotter than Q.
- B P has more heat than Q.
- C Both P and Q have the same temperature.
- D Both P and Q have the same amount of heat.

- (1) A and B only
- (2) A and D only
- (3) B and C only
- (4) C and D only

24. A group of pupils set up an electric circuit as shown below.

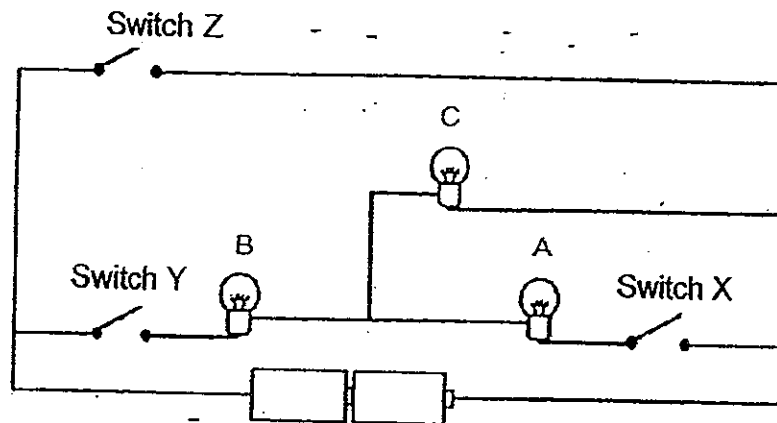

They made four observations about the electric circuit.

- Alvin: Bulbs B and C will light up when only switch Y is closed.
Bertrand: No bulb will light up when only switch Z is closed.
Caleb: Bulbs A and B will light up when only switches Y and Z are closed.
Danny: Bulbs A, B and C will light up when only switches X and Y are closed

Who has made the correct observation?

- (1) Caleb and Danny only
- (2) Alvin and Bertrand only
- (3) Alvin, Bertrand and Caleb only
- (4) Alvin, Bertrand and Danny only

25. Ryan set up two different circuits, A and B using identical batteries and light bulbs. He recorded the brightness of each light bulb in each circuit. He continued to add bulbs, one at a time, to both circuits. He presented his results in the two graphs below.

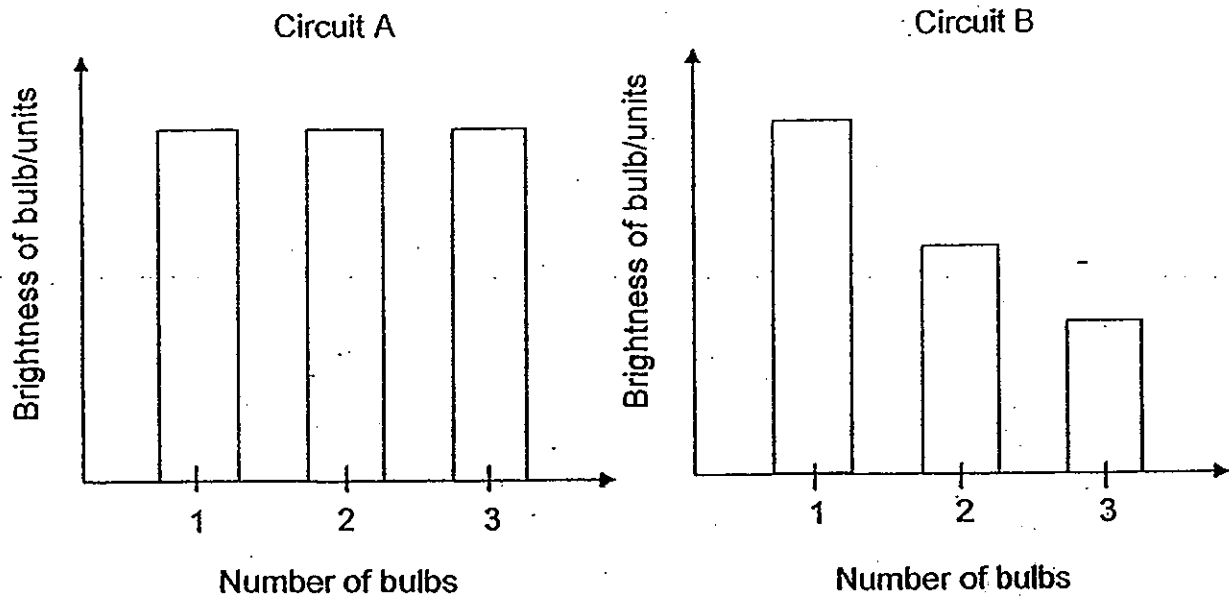

Based on the graphs above, which one of the following statements is true?

- (1) No bulbs will remain lit when more bulbs are added to Circuit B.
- (2) Batteries in Circuit B have a shorter life span than batteries in Circuit A.
- (3) Batteries in Circuit A have a shorter life span than batteries in Circuit B.
- (4) The rest of the bulbs would remain lit when one of the bulbs in Circuit B is blown.

26. Hassan set up an experiment as shown below. Both ping pong balls were of the same size. The strings are of the same length.

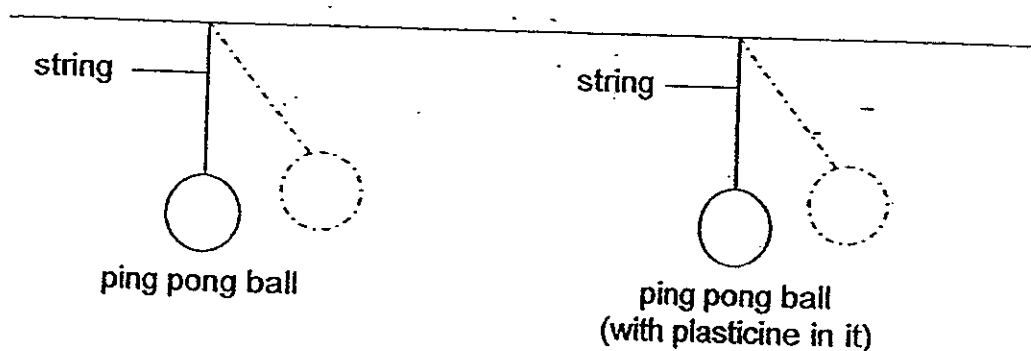

He lifted both balls to the same height, released them and allowed them to swing. He used a stopwatch to record the time taken for each ball to come to a stop.

The aim of the experiment is to find out if the _____

- (1) height at which the ball is raised affects how fast it swings
- (2) mass of the ball affects the time taken for it to come to stop
- (3) material of the ball affects the time taken for it to come to a stop
- (4) amount of gravitational potential energy the ball has affects how fast it swings

27. Penelope hung three balls of the same size (X, Y and Z) using three similar elastic bands of the same length on an affixed pole as shown in the diagram below.

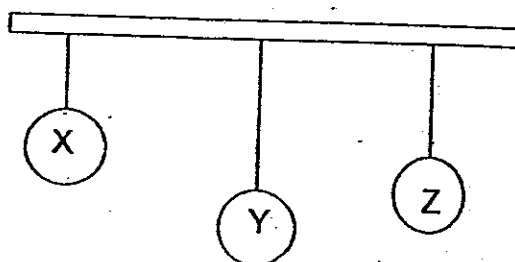

Which of the following statement(s) is/are definitely true?

- A Y is lighter than Z.
- B X has the smallest mass.
- C Y has the greatest amount of gravity acting on it.
- D All three balls have gravitational potential energy.

- (1) C only
- (2) B and D only
- (3) B, C and D only
- (4) A, B and C only

28. The diagram below shows a simple pendulum facing a magnet XY. Attached to the pendulum is another magnet.

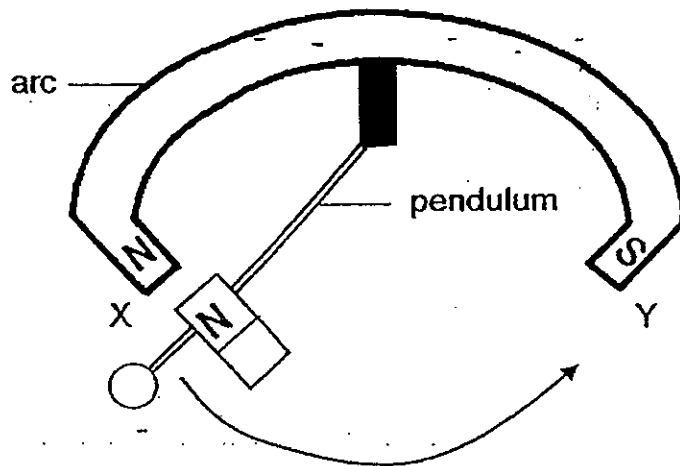

What forces are involved when the pendulum swings from X to Y?

- A Gravity
 - B Magnetic Force
 - C Air resistance acting on the pendulum
 - D Frictional force between the magnet on the pendulum and the arc
- (1) A and B only
(2) A, B and C only
(3) B, C and D only
(4) A, B, C and D

29. The picture below shows an electric baby cradle that will move the baby up and down to soothe the baby to sleep.

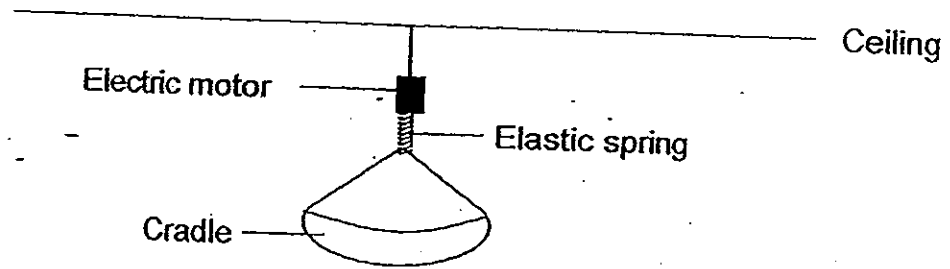

The electric motor was set to move the spring up and down for a period of two minutes. Which of the following pairs of graphs correctly shows the gravitational potential energy possessed by the baby and the gravitational force that is acting on the baby for the two minutes?

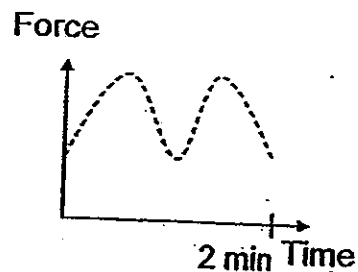
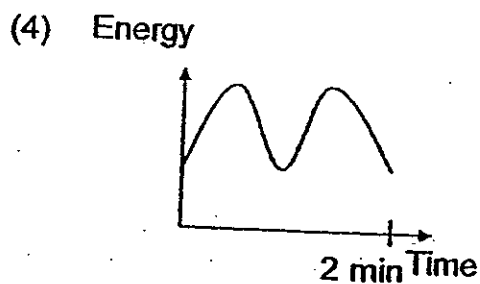
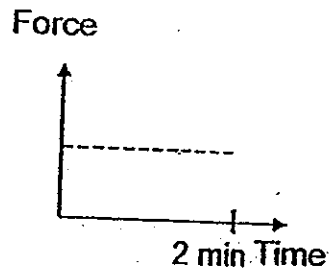
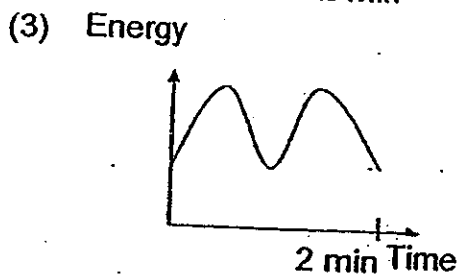
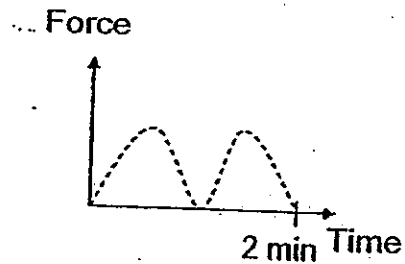
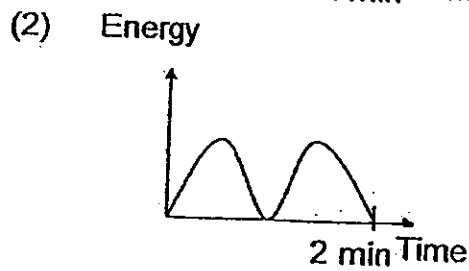
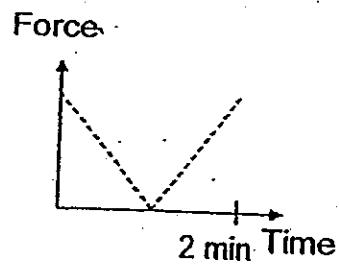
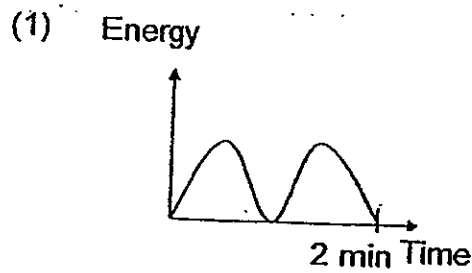

30. Daniel is given two batteries, 3 light bulbs, X, Y and Z and some wires. One of the light bulbs, X, is fused.

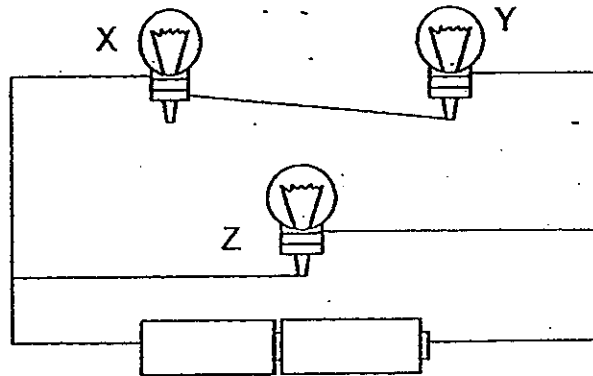

When he sets up the electric circuit as shown above, which of the bulb(s) will remain lit?

- (1) Bulb Y only
- (2) Bulb Z only
- (3) Bulb Y and Bulb Z only
- (4) None of the bulbs

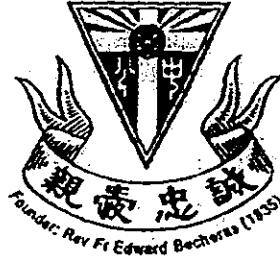

CATHOLIC HIGH SCHOOL
PRIMARY 6
PRELIM 2
EXAMINATION 2012

SCIENCE
EM 1 / EM 2

Name: _____ ()

Class : Primary 6 _____

Date : 27 August 2012

BOOKLET B

14 Questions
40 Marks

Total Time for Booklets A & B: 1 hour 45 minutes

Instructions to Candidates

Follow all instructions carefully.
Answer all questions.

Parent's Signature: _____

Date: _____

Score	
Section A	60
Section B	40
Total	100

Section B: Open-Ended Questions (40 marks)

Read the following questions carefully and write your answers in the space provided. The maximum marks that can be awarded are shown at the end of each question or part-question.

31. Jasmine wanted to conduct an experiment to find out whether Plant X or Plant Y takes in more water. She set up an experiment as shown below.

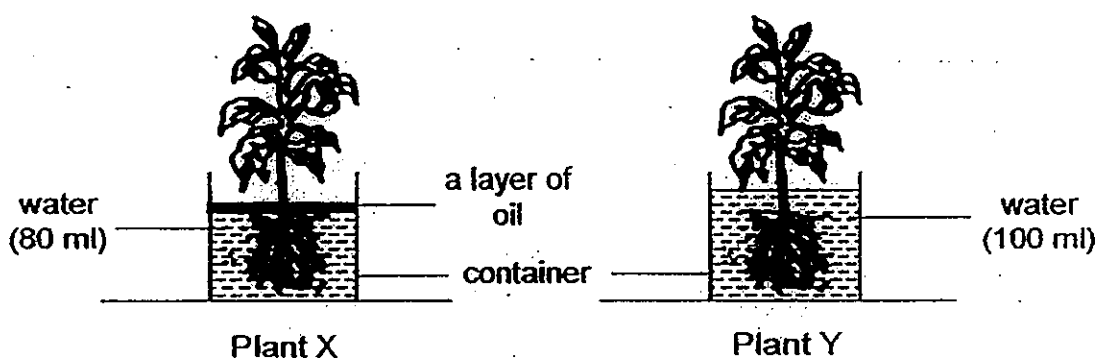

- (a) Jasmine's teacher told her that there are changes to be made to the set-ups before she could carry out her experiment. What two changes must Jasmine make to her set-ups? [1]

- (b) Why must Jasmine make changes to her set-ups before she conducts her experiment? [1]

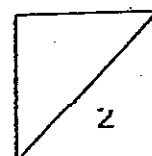

32. Jackson carried out an experiment on photosynthesis for 4 hours. He wanted to find out if the amount of baking soda would affect the rate of photosynthesis of the hydrilla plant.

He set up the following experiment shown below and left the 2 set-ups next to a window.

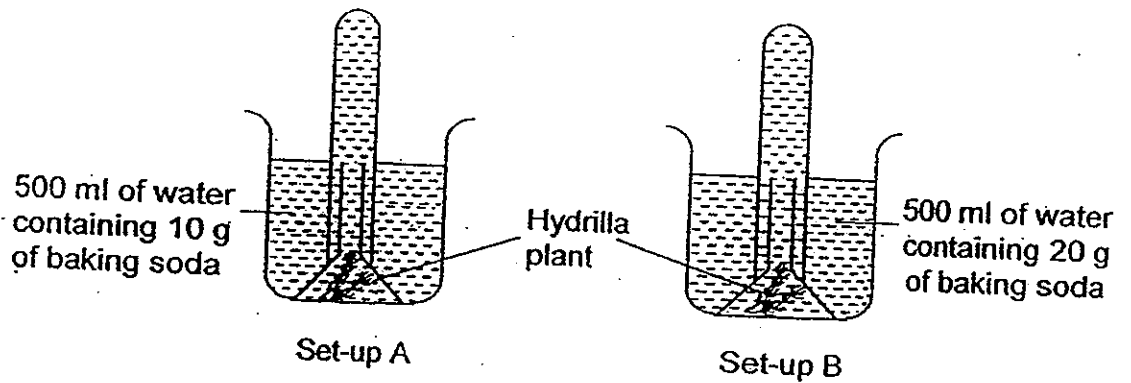

- (a) What data should he collect in order to arrive at a conclusion for the experiment?

[1]

- (b) His sister told him that his experiment could be further improved by adding a control set-up. What is the purpose of adding a control?

[1]

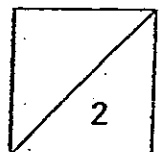

33. Sharon made the following observations of four animal pollinators while at the Singapore Botanic Gardens.

Pollinator	Observations
Honey bee	<ul style="list-style-type: none"> • Prefers yellow and blue flowers • Likes sweet-scented flowers
Humming bird	<ul style="list-style-type: none"> • Has a long beak • Likes brightly-coloured flowers • Hovers at flowers, rather than landing on the petals
Butterfly	<ul style="list-style-type: none"> • Likes brightly-coloured flowers • Feeds by perching on the flowers
Bat	<ul style="list-style-type: none"> • Is nocturnal • Has a good sense of smell • Likes white or light-coloured flowers which open at night

Study Flower A and B below.

	<p>Flower A</p> <p><u>Characteristics</u></p> <p>Colour: Red</p> <p>Nectar is found at the base of the flower.</p> <p>Photograph source: http://mestl.kr/sub_read.html?uid=10560&section=sc3</p>
---	--

	<p>Flower B</p> <p><u>Characteristics</u></p> <p>Colour: Cream</p> <p>Flowers open after the sun sets.</p> <p>Photograph source: flickr.com</p>
---	---

- (a) Based on Sharon's observations, identify the pollinator which is most likely to pollinate Flower A and B by completing the table below. [1]

Flower A	Flower B

- (b) Sharon came across a fruit with a wing-like structure. She decided to carry out an investigation on the fruit.

She found three similar fruits, P, Q and R and cut off parts of the wing-like structures on them. She then dropped each fruit from the same height and noted the time taken for the fruit to reach the ground. She recorded her results in the table shown below.

Fruit	Surface area of wing-like structure/cm ³	Time taken for fruit to reach the ground/seconds
P	8.6	4.1
Q	6.4	3.0
R	5.2	2.5

- (i) What is the aim of Sharon's experiment? [1]

- (ii) Sharon's teacher told her that she could improve the reliability of her results further. What improvements should Sharon make to her experiment? [1]

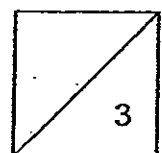

34. The diagram below shows the location of a town situated next to a river.

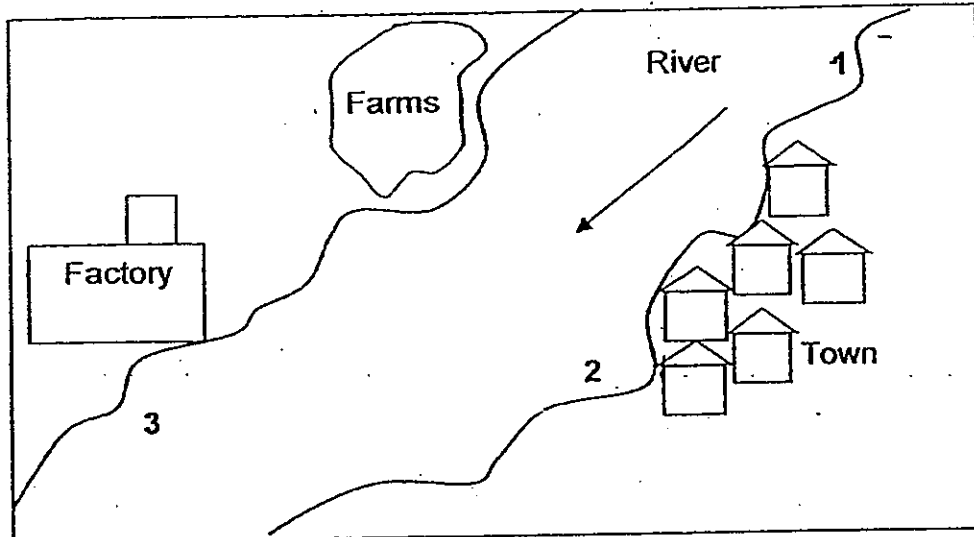

Chin Kwang collected samples of river water at points 1, 2 and 3. All the samples contain the same volume of water. He counted the number of Organisms X, Y and Z and measured the amount of dissolved oxygen in each sample. His data was tabulated in the tables below.

Point	Number of organisms		
	X	Y	Z
1	24	13	2
2	19	9	6
3	3	1	18

Point	Amount of dissolved oxygen/units
1	8.5
2	7.6
3	2.1

- (a) What is the relationship between the number of Organisms X, Y and Z and the amount of dissolved oxygen in river water? [1]

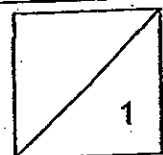

- (b) A pollutant was found present in the sample of water from Point 3. Based on the data collected, what could Chin Kwang conclude about the effect of the pollutant on the populations of Organisms X, Y and Z? [1]
-
-

- (c) Chin Kwang suspected that the factory was responsible for the release of the pollutant into the river.

Mark an "X" on the part of the river where he should collect another sample of water to confirm his suspicion. [1]

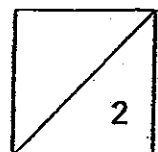

35. The picture below shows a robber fly and a bumblebee. A robber fly is often mistaken for a bumble bee. A robber fly feeds on bees. (The diagrams are not drawn to scale.)



Bumblebee



Robber fly

- (ai) Name the structural adaptation that the robber fly has. [1]

- (aii) How does the structural adaptation from your answer in part (i) benefit the robber fly? [1]

- (b) Based on the diagrams above, identify one difference between the bumble bee's and the robber fly's thorax area. (Do not mention shape or size.) [1]

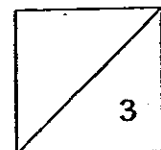

36. A crocodile is well adapted to life in water. The picture below shows how a crocodile usually hunts for their prey along the river side.



- (a) Animals, such as zebras, have to be very careful when they are drinking water from the edge of rivers where crocodiles live. Based on the picture above, explain why the crocodile can spot its prey easily while it is difficult for its prey to notice it from its drinking spot. [2]
-
-
-
- (b) Explain how the nostrils of the crocodile help it when it is in the position shown above. [1]
-
-
- (c) Name a behavioural adaptation that a crocodile has that allows it to hunt its prey easily. [1]
-
-

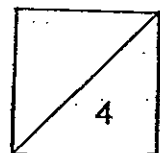

37. Wei Ming caught 4 types of fish, A, B, C and D from a river and brought them home. He conducted 3 experiments to find out more about the food relationship between fish A, B, C and D. Each experiment is carried out in an aquarium.

The table below shows his observations of the experiments conducted over 3 days.

Experiment	Start of experiment	End of experiment
1	2 Fish A 2 Fish C 2 Fish D	2 Fish A
2	5 Water plants 1 Fish C 1 Fish D	1 Water plant 1 Fish C 1 Fish D
3	5 Water plants 4 Fish A 2 Fish B	5 Water Plants 2 Fish B

- (a) Based on the results of his experiments, construct a possible food web to show the relationship between the 4 types of fish. [1]

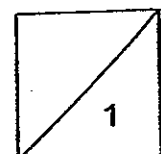

- (b) The diagram below shows a food web of 5 organisms, M, N, O, P and Q, in Wei Ming's garden.

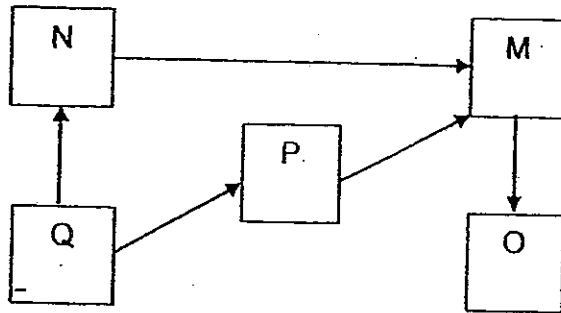

One of the organisms is a plant and its population size has been decreasing over the past few months. Wei Ming wanted the plant population to increase eventually. Without adding more plants, he planned to introduce more of one type of organism.

Which one of the above organisms, M, N, O, P or Q should Wei Ming add? Explain your answer. [2]

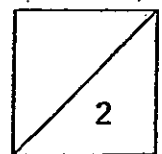

38. Kristine bought a new cleaning device designed to clean the outer surface of windows from the inside. The device uses two magnets as shown in the diagram below.

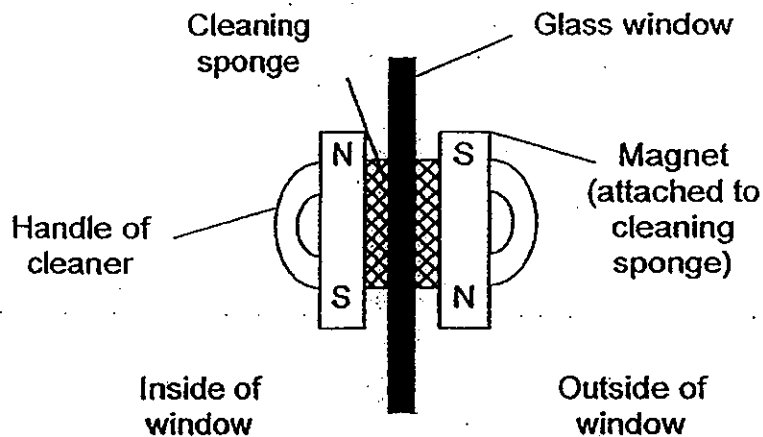

Kristine has to hold the handle of the cleaner which is on the inside of the window and slide it up and down in order to use the cleaning device. The two cleaning sponges will move together.

- (a) Explain how this cleaning device works in helping Kristine to clean her windows. [2]

- (b) Kristine realised that there was a warning sign on the cleaning device which states that it could only be used on windows with a thickness of not more than 3 cm.

Give a reason why this cleaning device cannot be used to clean windows of more than 3 cm in thickness. [1]

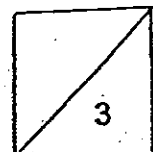

39. Matthew wanted to find out how the size of ice cubes affects the temperature of water. He filled two similar beakers with 200 ml of water at room temperature of 29°C. He placed an ice cube of 100 cm³ in one beaker and an ice cube of 50 cm³ in another beaker.

He recorded his observations in the following table.

Time / s	Temperature of water / °C	
	Beaker A	Beaker B
60	25	21
120	22	18
180	19	15
240	12	12

- (a) Based on Matthew's observations, state which beaker contained the ice cube of 100 cm³. Provide a reason for your answer. [1]

- (b) What is the relationship between the size of ice cube placed in the beaker and the time taken for the temperature of water in the beaker to decrease? [1]

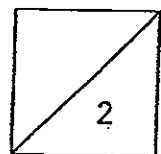

40. The diagram below shows the quality control room in a glass-making factory.

A light sensor is used to determine the thickness of glass sheets on a moving belt. The belt moves at a constant speed. Glass sheets which do not meet the standard thickness are rejected.

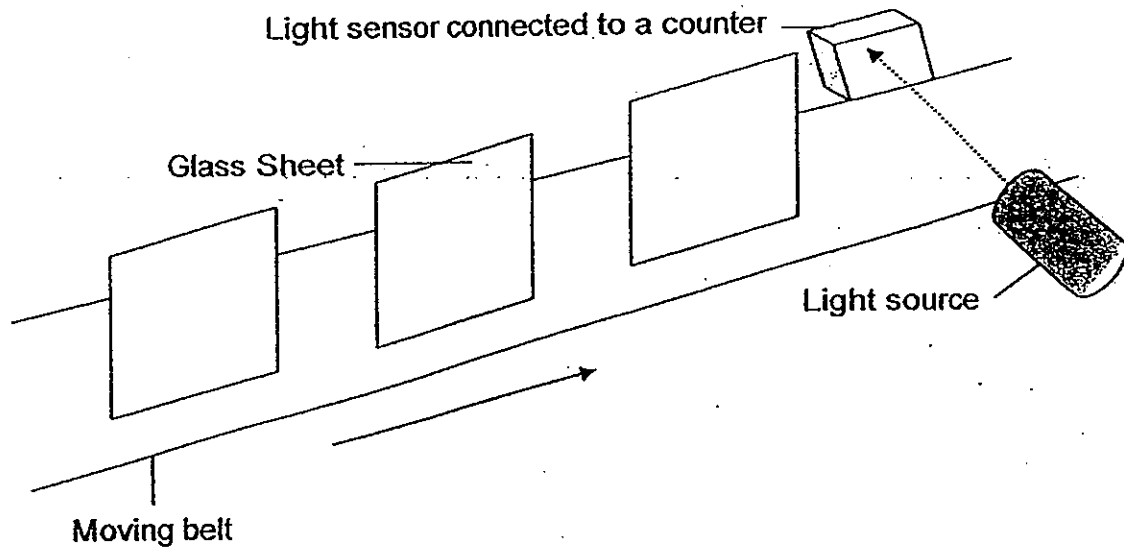

An employee observed and counted the number of glass sheets which passed the quality control. He recorded his data in the graph shown below.

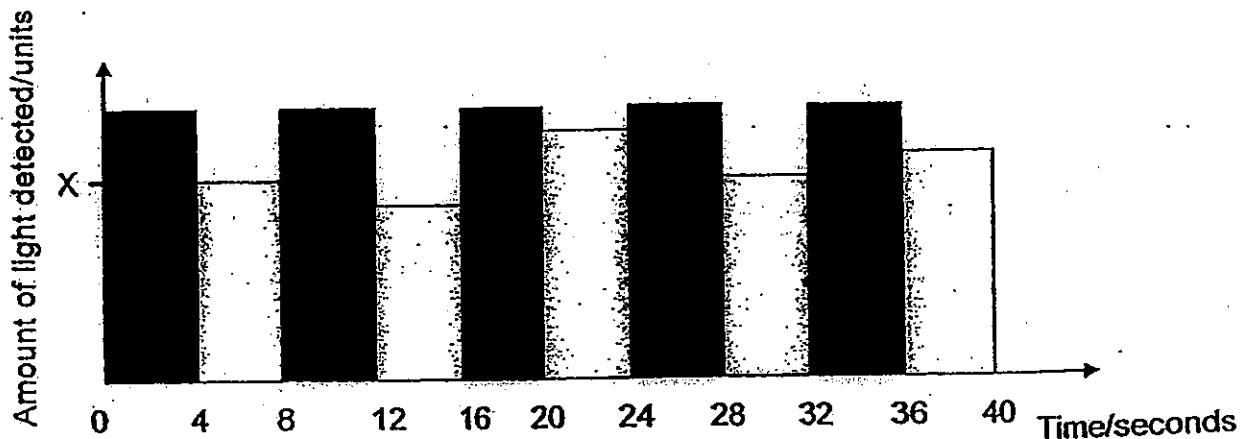

X represents the amount of light detected by the light sensor when a glass sheet of an acceptable thickness moves past the light source.

- (a) Based on the graph above, how many glass sheet(s) has/have to be rejected? [1]

- (b) Alvin bought some glass sheets home. He prepared the set-up as shown below.

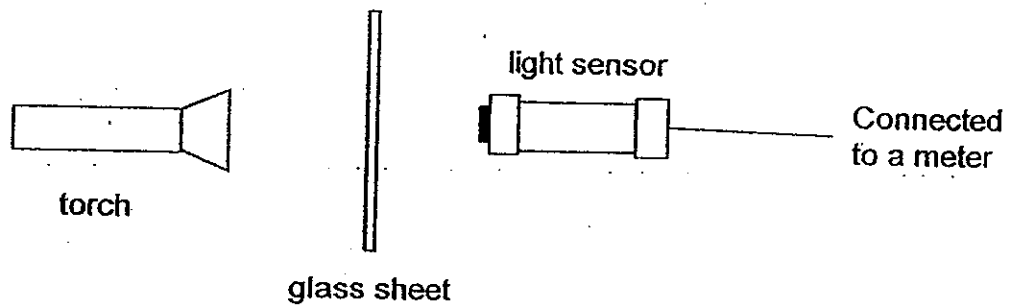

He conducted an experiment by using a different number of glass sheets. The table below shows his result.

Number of sheets	Amount of light detected /units
0	250
1	235
2	219
3	207

- (i) Alvin carried out his experiment in a dark room. Explain why he did so. [1]

- (ii) Based on the results above, explain the difference in the amount of light detected when 0 and 1 sheet of glass is used. [1]

41. In winter, houses are heated so that the indoor temperature is higher than the outdoor temperature.

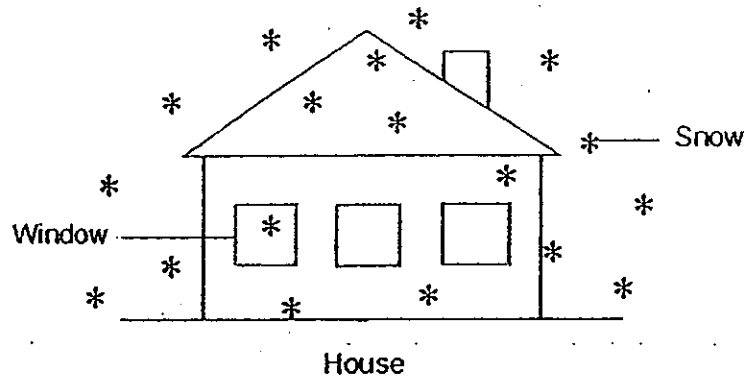

- (a) When the window is made of a single sheet of glass, condensation takes place on the surface of the glass facing indoors. Explain why this happens.

[1]

A double glass-window consists of 2 glass sheets separated by a layer of air as shown in the diagram below. This is to prevent condensation on the surface of glass sheet B facing indoors.

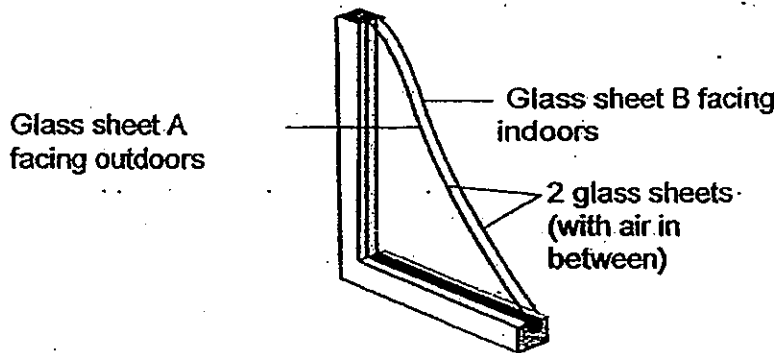

- (b) Explain why double-glass windows can prevent condensation on the surface of glass sheet B facing indoors.

[2]

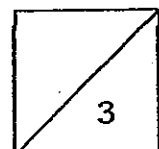

42. May was given three batteries, three bulbs, some wires and Rod A, Rod B and Rod C to carry out an investigation. She wanted to find out which of the three rods, A, B and C, is a conductor of electricity. May used all the given materials in one set-up.

(ai) In the space provided below, draw a circuit diagram to show her set-up. [2]

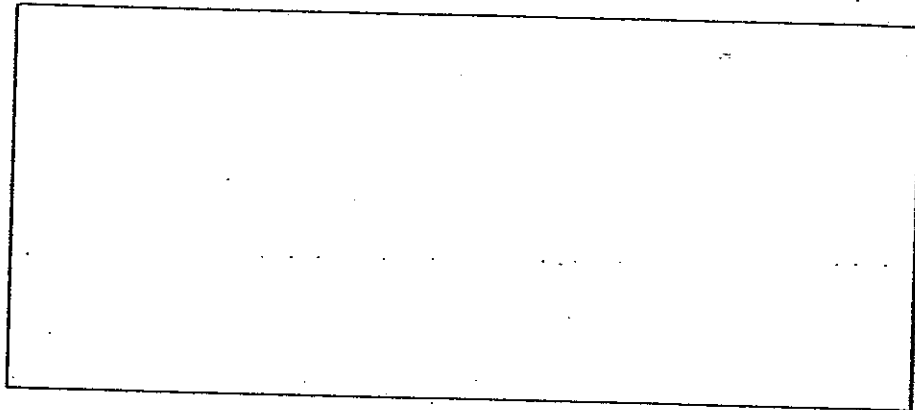

(aii) How can May conclude which rod is a conductor of electricity? [1]

(b) June set up the circuit as shown below. All the light bulbs were shining brightly at first.

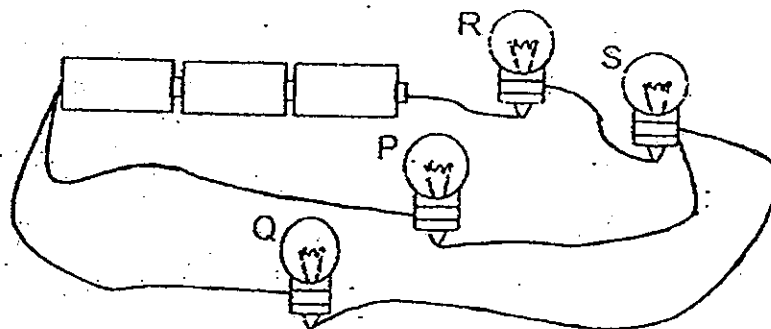

After some time, one light bulb fused, but the other three remained lit. Which bulb had fused? Explain your answer.

[1]

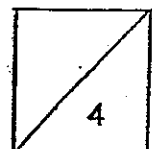

43. - The diagrams below show the side view and front view of a wind turbine.

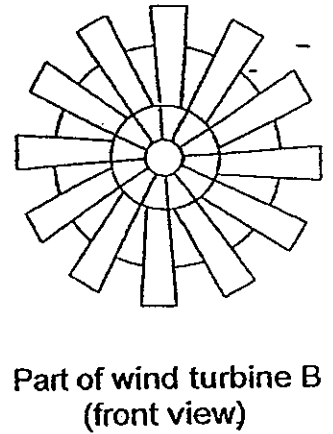
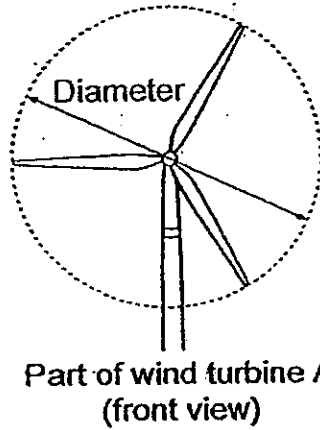
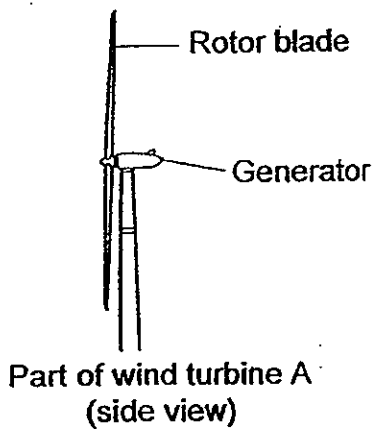

(a) State the energy changes that take place in a wind turbine. [1]

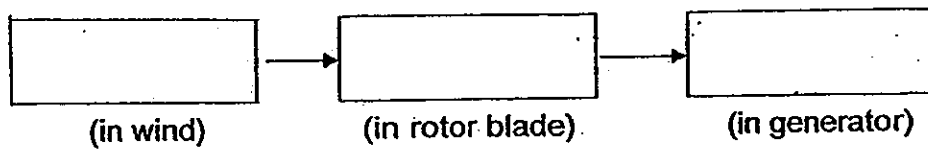

(b) Although the diameters of wind turbines A and B are the same, wind turbine B is not able to generate as much electricity as wind turbine A. State the reason to explain why. [2]

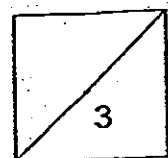

44. Paul was walking down a gradual cement slope when he noticed some small particles on the slope. He walked down the slope and almost slipped and fell. He collected some of these particles and observed them under a magnifying glass. The picture below shows what Paul observed.

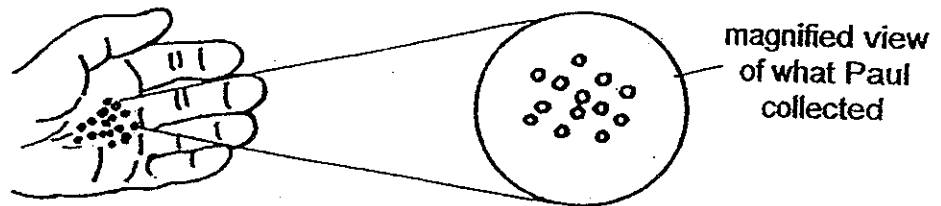

- (a) Explain why Paul almost fell when he walked down the slope. [1]

- (b) If the particles were partly cemented into the surface of the slope, would Paul have almost slipped and fallen too? [1]

-END OF PAPER-

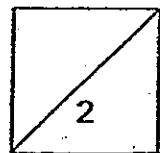



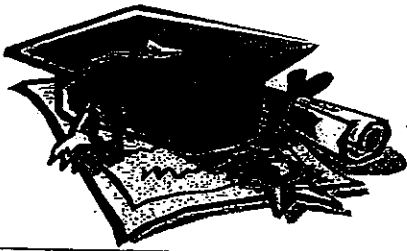

ANSWER SHEET

EXAM PAPER 2012

SCHOOL : CATHOLIC HIGH
SUBJECT : PRIMARY 6 SCIENCE

TERM : SA2

Q1	Q2	Q3	Q4	Q5	Q6	Q7	Q8	Q9	Q10	Q11	Q12	Q13	Q14	Q15	Q16	Q17
1	1	3	2	1	1	3	4	4	2	2	4	3	3	1	3	4
Q18	Q19	Q20	Q21	Q22	Q23	Q24	Q25	Q26	Q27	Q28	Q29	Q30				
2	3	2	3	3	2	4	3	1	2	1	2	3				

31)a)The volume of water in each set-up must be the same. There must be a layer of oil in the set-up with Plant Y.

b)There should only be one changed variable (plant X and Plant Y)and all other variable should be the same to ensure a fair test.

32)a)The number of bubbles in the test-tube.

b)As a comparison against the rest of the set-ups to prove that the rate of photosynthesis depends on the amount of baking soda.

33)a)Flower A: Humming birds

Flower B: Bat

b)i)To find out how the surface area of the fruit affects the time taken for it to reach the ground.

ii)Repeat the experiment two more times and take the average time.

34)a)The greater the amount of dissolved oxygen in the river water, the greater the number of organisms X and Y present and the smaller the number of Z.

b)The presence of the pollutant has led to a decrease in the number of X and Y and an increase in the number of Z.

35)a)i)Mimicry.

ii)The bumblebee will mistake the robber fly as its kind so it will not fly away giving the robber fly the chance to eat it.

b)The bumblebee has two thorax but the robber fly has one thorax.

36)a)Most of the crocodile's body is hidden in the water.

b)The nostrils are located near the top of the crocodile's head which enables it to take in air from the atmosphere.

c)It moves silently in water.

37)a)

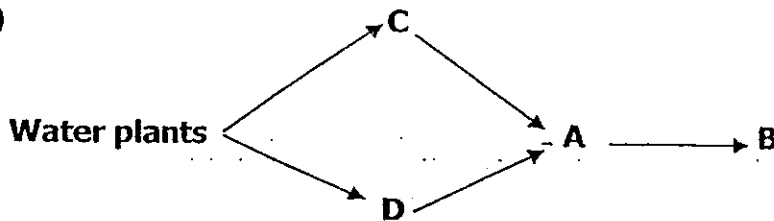

b)He should add M.

Q is the plant and both P and N feed on it. When more M is added, it will feed on more P and M. Hence, there are less P and N to feed on Q.

38)a)The unlike poles of the magnets attract each other as magnetism can pass through glass.

b)Magnetism cannot pass through when the glass is more than 3cm.

39)a)B. The water in B loses more heat to the 100cm³ ice cube as compared to the water in A with the 50cm³ ice cube.

b)The bigger the size of ice cube placed in the beaker, the shorter is the time taken for the temperature of water in the beaker to decrease.

40)a)3.

b)i)To ensure that the only light detected by the light sensor comes from the torch.

ii)The sheet of glass prevents some light from passing through, hence less light is detected by the light sensor.

41)a)Water vapour in the house condenses on the cool surface of the glass facing indoors.

b)Air is a poor conductor of heat so it helps to reduce loss of heat.

42)a)i)

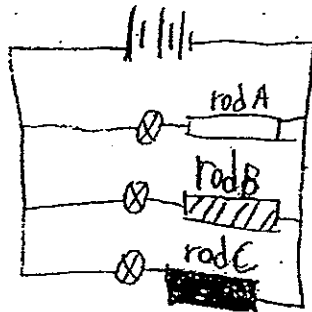

ii) The light bulb next to the rod will light up when the rod is a conductor of electricity.

b) P. It is arranged in parallel to the other light bulbs so electricity can still flow to other bulbs.

43)a) Kinetic energy \rightarrow Kinetic energy \rightarrow Electrical energy

b) With more rotor blades, the mass of the wind turbine B will increase. This increase in mass will result in more kinetic energy required to turn B. Therefore, there will be less kinetic energy available to be converted to electricity.

44)a) The particles reduced the friction Paul's shoes and the slope.

b) No. The embedded particles will increase the friction between Paul's shoes and the slope.

